

VANDAL RESISTANT TWO BUTTON DOOR ENTRY KIT WITH CODED ACCESS

VR4K-2/CL



TECHNICAL MANUAL
EDITION 1.0

WV
VIDEX
The Power to Secure

MANUAL INTRODUCTION

The information in this manual is intended as an installation and commissioning guide for the vandal resistant two button audio intercom kit. This manual should be read carefully before the installation commences. Any damage caused to the equipment due to faulty installations where the information in this manual has not been followed is not the responsibility of Videx Security Ltd.

VIDEX run free training courses for engineers who are not familiar with the Videx product range. Technical help is also available on 0191 224 3174 during office hours or via e-mail tech@videx-security.com.

SYSTEM INTRODUCTION

This kit will enable a caller at an entrance point to signal an occupant in the dwelling by pressing a call button which will send an electronic call tone to an audio telephone. A Yellow 'SPEAK' LED will indicate the call has been answered and a two way conversation can take place, the occupant can release an electric lock release by pressing a button on the telephone base unit. The kit does not include the electric lock release. A 12V AC release should be used with this kit (The output for the lock is a dry contact relay so any other type of lock can be used with an appropriate PSU). If this kit is to be used with a gate, the dry contact output can be used to trigger the gate control board. DDA features such as a 'SPEAK' LED, 'DOOR OPEN' LED and reassurance tones are standard on this kit.

A three code, three relay codelock unit is also incorporated into the door panel to allow users to gain access using an access code.

SYSTEM COMPONENTS

This kit comprises of a flush or surface vandal resistant door panel, audio telephone and PSU. Up to a maximum of three telephones can be used on the system to call in parallel.

DOOR PANEL

The vandal resistant door panel will consist of an amplifier module, codelock module, two buttons, vandal resistant plate, frame and back box.

Dip-Switches

The four way dip-switch bank has the following functions. Please note: dip-switches must be set before power up. Any changes made when power is on will not take effect until a power down reset.

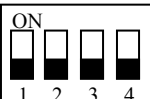
	Speech time		Relay time		Speech live	
	Switch 1 OFF	1 Minute	Switch 2 OFF Switch 3 OFF	2 Seconds	Switch 4 OFF	Only when called
	Switch 1 ON	2 Minutes	Switch 2 OFF Switch 3 ON	4 Seconds	Switch 4 ON (Only possible on one door systems)	Speech live whenever a handset is lifted
			Switch 2 ON Switch 3 OFF	8 Seconds		
			Switch 2 ON Switch 3 ON	20 Seconds		

Jumper

Jumper JP controls the reassurance tone volume level at the door panel.

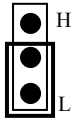

Position H	High volume reassurance tones
Position L	Low Volume reassurance tones
No Jumper	No reassurance tones

POTS

Speech volume adjustments are carried out at the door panel using a small trimmer driver.



Adjustment for
speech volume at the
apartment



Adjustment for
speech volume level
at the door station

Amplifier module (VX136)

Connection	Function
1	Receive speech from apartment
2	Transmit speech to apartment
+	+12Vdc input
-	0V (Ground)
5	Switched 0V from phone to trigger door release relay
T	Electronic call tone output to common side of call buttons
-	0V for use with push to exit input (PTE)
PTE	Switched 0V input from push to exit button to trigger door release relay
C	Common connection of dry contact relay
NC	Normally closed connection of dry contact relay
NO	Normally open connection of dry contact relay
D+	External link to door open (+12V side) LED. Not used with this kit
D-	External link to door open (0V side) LED. Not used with this kit
BSY	Busy signal for use with multiple door systems (Normally high, 12V. Low when busy 0V)
SL	Switched 0V output to switch on video PSU. (0V throughout a call, open collector in standby)
F1	Switched 0V output to switch on camera. (0V throughout a call, open collector in standby)

CodeLock module (Art.4800)

Connection	Function
+	12-24V ac/dc power input
-	0V power input
C1	Common connection of relay 1 (Dry contact)
NO1	Normally open connection of relay 1 (Dry contact)
NC1	Normally closed connection of relay 1 (Dry contact)
C2	Common connection of relay 2 (Dry contact)
NO2	Normally open connection of relay 2 (Dry contact)
NC2	Normally closed connection of relay 2 (Dry contact)
C3	Common connection of relay 3 (Dry contact)
NO3	Normally open connection of relay 3 (Dry contact)
NC3	Normally closed connection of relay 3 (Dry contact)
SW1	Push to exit input for relay 1 (Triggered by 0V)
SW2	Push to exit input for relay 2 (Triggered by 0V)

Dimensions

	PANEL	FLUSH BACK BOX
Surface Audio panel with codelock	135mm(W) x 280mm(H) x 43mm(D)	NA
Flush Audio panel with codelock	135mm(W) x 280mm(H) x 16mm(D)	120mm(W) x 263mm(H) x 30mm(D)

POWER SUPPLY

Art.520M

The power supply is the Art.520M. Outputs of 12Vdc (200mA), 8Vdc (300mA) and 13Vac (1A) are available. The dc outputs are designed to power the amplifier modules only and must not be used to power other devices such as lock releases etc. These items must be connected to the AC output of this power supply or auxiliary power supply.

CONNECTIONS

Terminal	Function
+12	12Vdc output (200mA Max.)
+8	8Vdc output (300mA Max.)
-	0V (Ground)
~	13Vac (1A Max.)
230	Mains in (Live connection)
0	Mains in (Neutral connection)

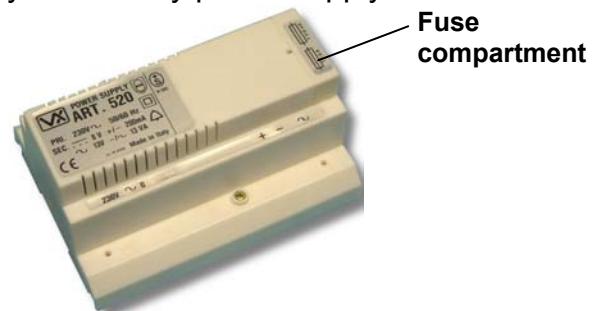

TELEPHONE

Art.3111

The Art.3111 is a white ABS plastic wall mounting electronic call telephone and includes a lock release push button and spare dry contact button. There is a three position call volume control external to the top left side of the telephone.

CONNECTIONS:-

	Function
1	Transmit speech to the door panel
2	Receive speech from the door panel
3	0V
4	Call tone input
5	Lock trigger (Switched 0V)
6	Not used
8	One side of spare dry contact button (Max. 200mA 24V)
9	Second side of spare dry contact button (Max. 200mA 24V)

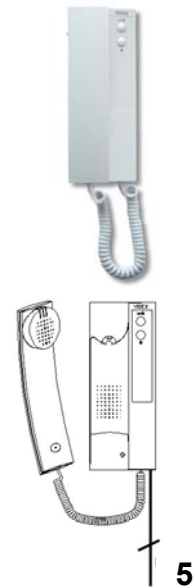

BLOCK DIAGRAM

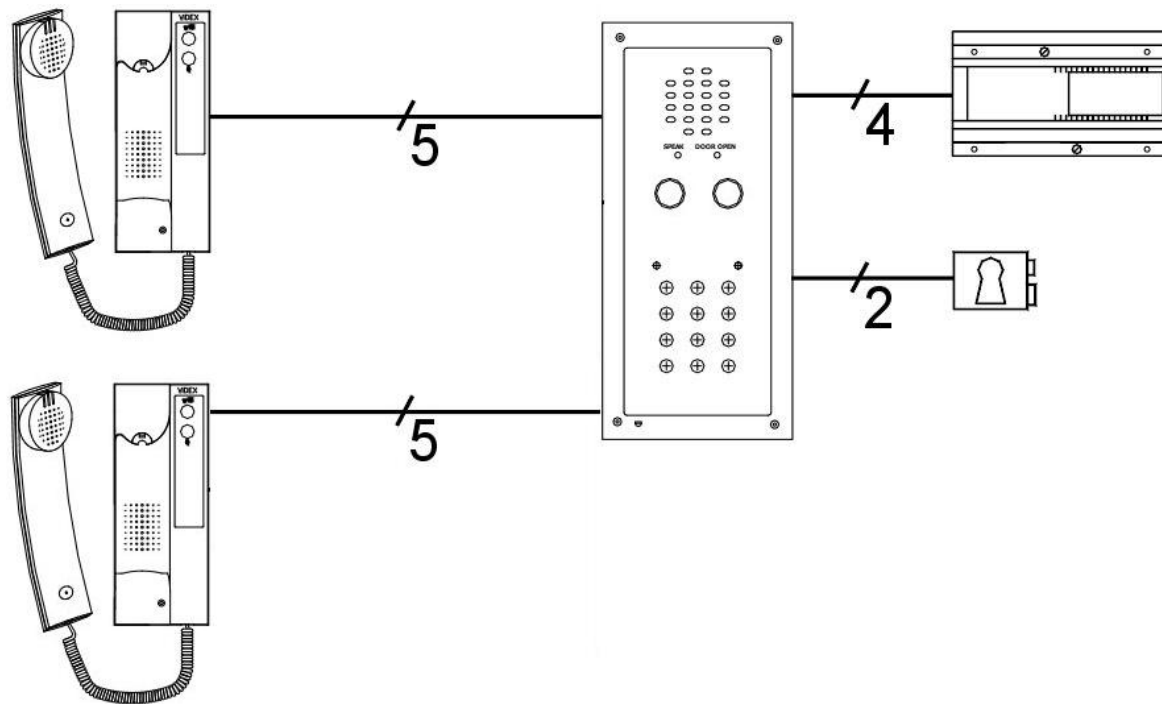

INSTALLATION

The wiring diagram towards the back of this manual should be followed carefully. Heavy duty conductors on wiring diagrams are shown heavily outlined, these wires should be doubled up.

- Check that all components are free from damage before installing (Do not proceed with installation in the event of damage).
- Keep all packaging away from children.
- Do not obstruct the ventilation openings or slots on any of the devices.
- All connections to mains voltages must be made to the current national standards (IEE Wiring regulations)
- Install an appropriate fused spur or isolation switch to isolate the mains.
- Isolate the mains before carrying out any maintenance work on the system.
- All intercom and access control cables must be routed separately from the mains.
- When the panel is mounted on an uneven surface, use additional sealant to protect from water ingress.

Lock release back EMF protection : A capacitor should be fitted across the terminals on an AC lock release as shown in the diagram below to suppress back EMF voltages.

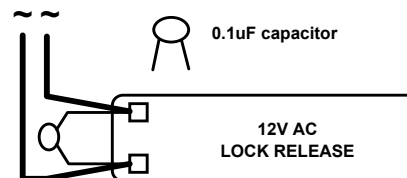

CABLE SIZE GUIDE

Connections from door panel to telephone.

Connections	50m	100m	200m	300m	400m
1	0.25mm ²	0.35mm ²	0.5mm ²	0.75mm ²	1.0mm ²
2	0.25mm ²	0.35mm ²	0.5mm ²	0.75mm ²	1.0mm ²
3	0.25mm ²	0.35mm ²	0.5mm ²	0.75mm ²	1.0mm ²
4	0.25mm ²	0.35mm ²	0.5mm ²	0.75mm ²	1.0mm ²
5	0.25mm ²	0.35mm ²	0.5mm ²	0.75mm ²	1.0mm ²

Maximum acceptable resistance for all terminals = 10Ω

Connections for power supply output to door panel and lock release connections. These connections are shown heavily outlined on the wiring diagram.

	50m	100m
Connections	0.5mm ²	0.75mm ²

The power supply should be located as close to the door panel as possible for best performance.
Maximum acceptable resistance for above cables = 3Ω

TESTING THE INSTALLATION

- Check all the connections have been made correctly and dip-switches have been set and then power up the system.
- Call the apartments. Check for call to the apartment, speech in both directions and lock release and correct operation of the SPEAK & DOOR OPEN LED's.
- If the volume of speech needs to be adjusted, this can be done by adjusting the presets on the rear of the amplifier at the door panel.
- Program a code into the codelock and check it releases the door for the programmed time.

PANEL CARE

The door panel is manufactured from 12 Gauge 304 grade stainless steel. It is important that the facia is cleaned on regular occasions to prevent dirt build up and tarnishing of the metal. A general household metal polish can be used but care should be taken to follow the grain of the metal when polishing and also avoid any polish build up around the call button which may prevent the button from operating correctly.

ACCESSORIES CONNECTION GUIDE

512A Extension sounder

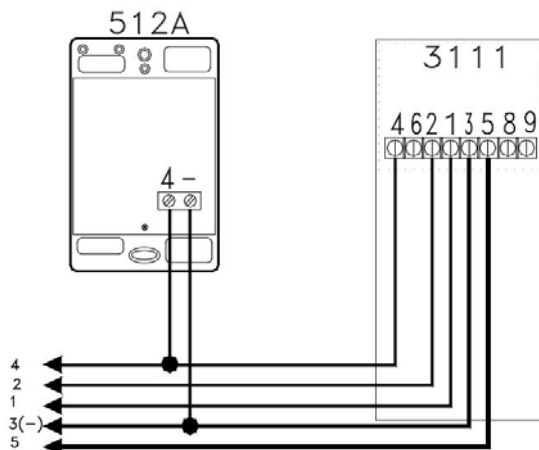

ES/1 Extension Strobe

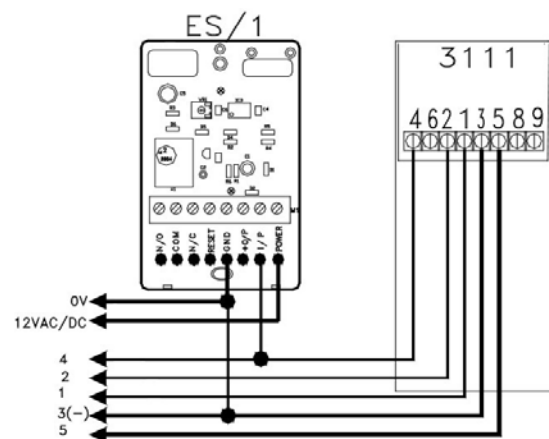

- A normally open push to exit button can be connected across PTE & - on the door panel.
- When triggering a gate, use C & NO as dry contacts.
- When using a fail safe lock release use a separate DC PSU and the NC connection instead of the NO connection.
- Remember to fit the 0.1uF capacitor across the lock release.

WIRING DIAGRAM

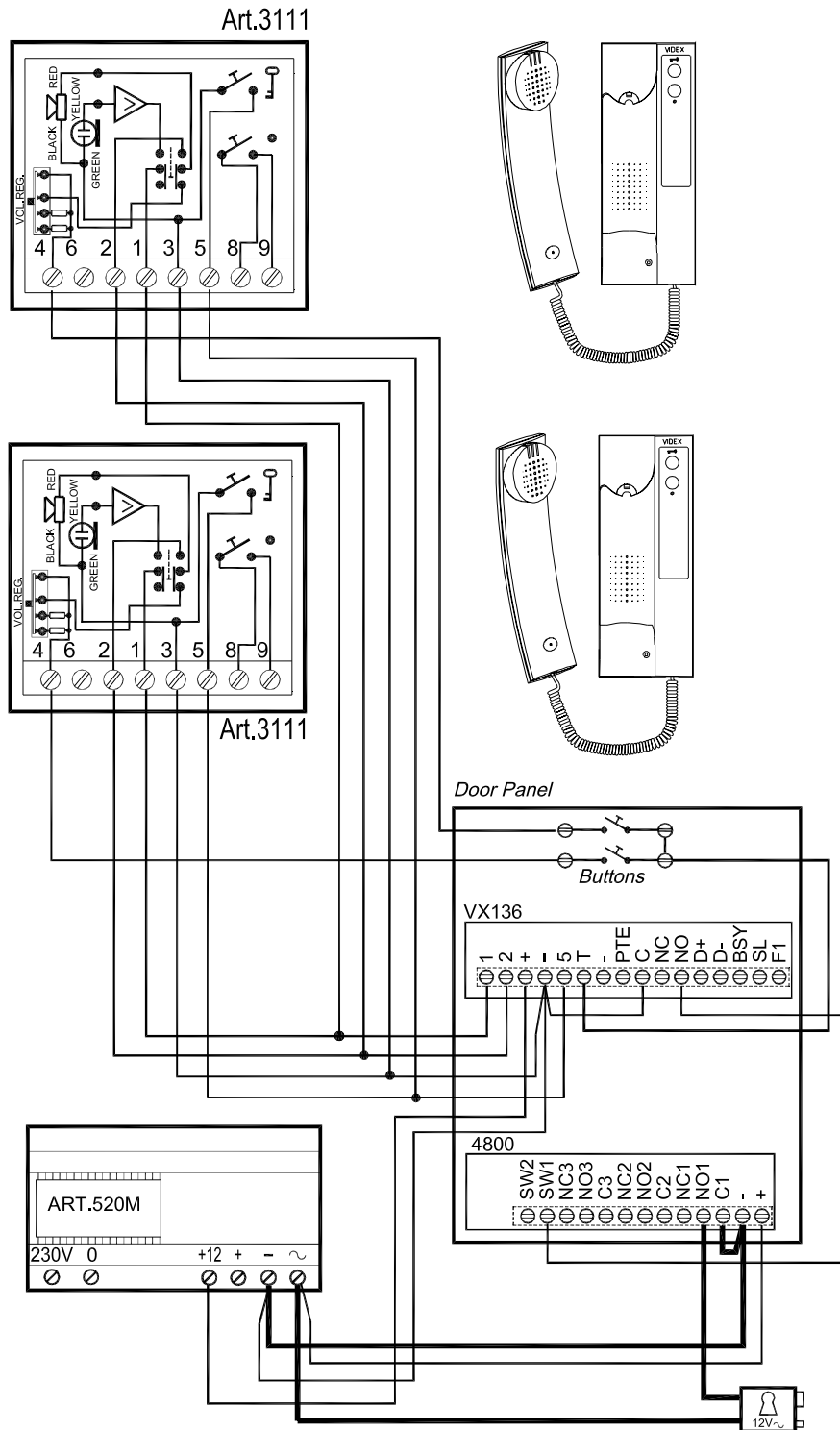

4800 CODELOCK

The 4800 includes three relays (5A contacts), two push to exit inputs (Switched negative) and can have up to three 4-8 digit access codes (One per relay). The relay times can be programmed from 01 to 99 seconds or by setting the relay time to 00, latch the relay (To latch, enter the code followed by enter and to unlatch enter the code followed by clear).

INITIAL PROGRAMMING

All programming is carried out using the code lock keypad. The programming menu is protected by an engineer's code. The factory default engineers code is 111111 (6x1). This code can be changed to any four to eight digit code during the program but must be different to the codes used to gain entry. Follow the flow chart to setup the system:-

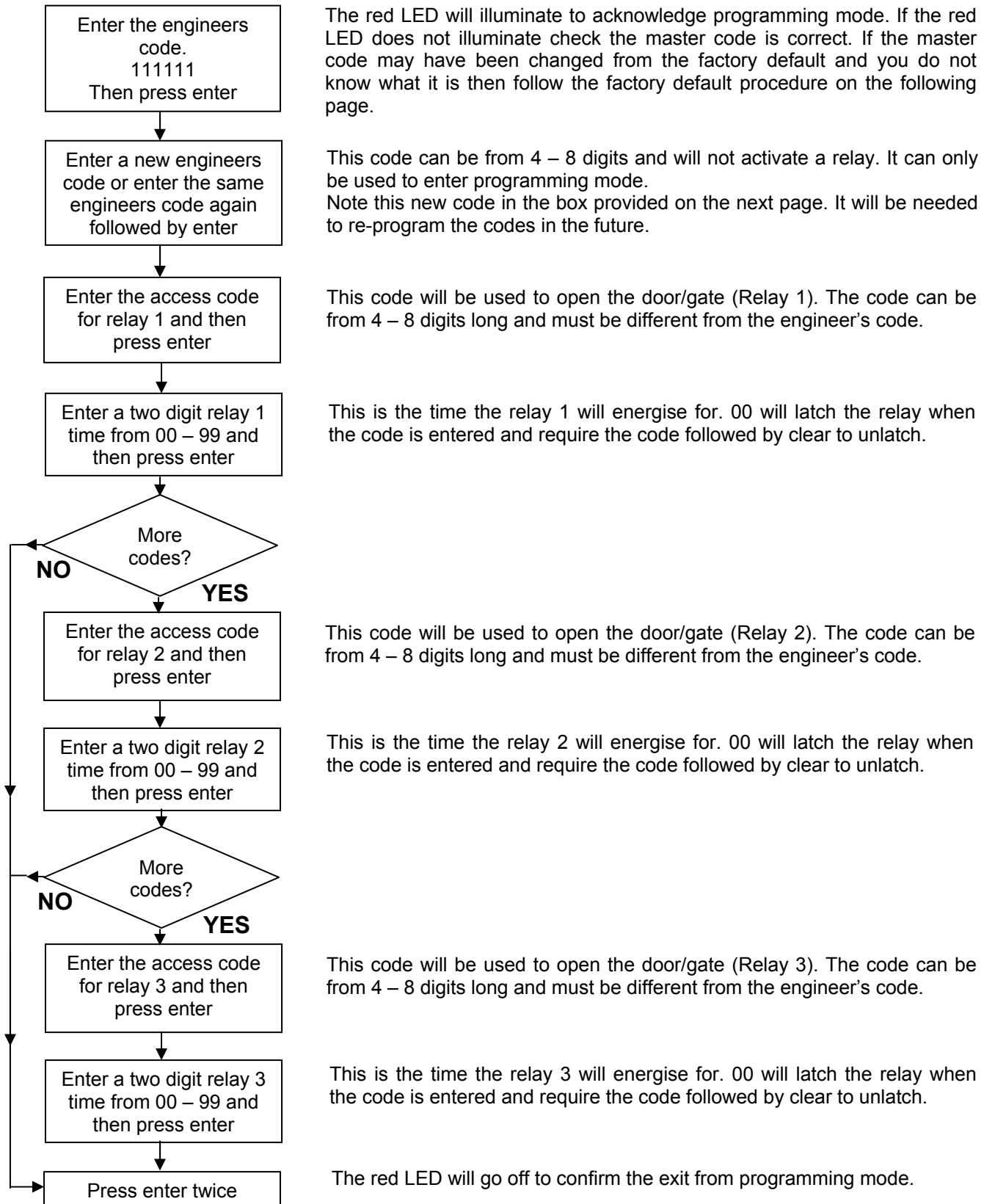

4800 CODELOCK REPROGRAMMING GUIDE

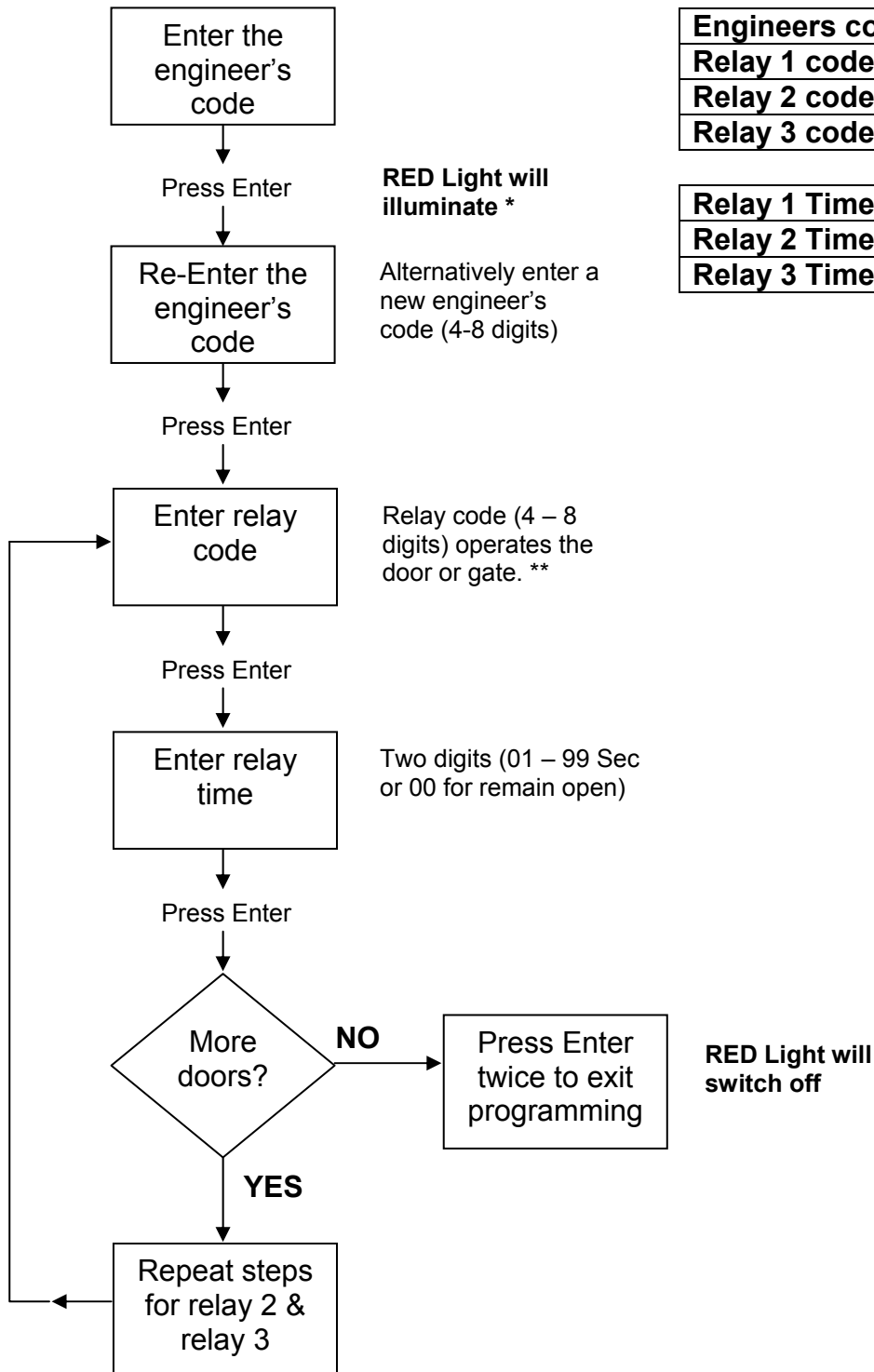

Engineers code	
Relay 1 code	
Relay 2 code	
Relay 3 code	

Relay 1 Time	
Relay 2 Time	
Relay 3 Time	

Notes:

* If the red light does not illuminate, the engineers code is incorrect. Follow the factory default procedure below.

** On the first loop of the flow chart its relay 1, second loop is relay 2.

FACTORY DEFAULT PROCEDURE

Step 1 Remove the power from the keypad

Step 2 Press and hold the enter button while re-powering the keypad

Step 3 Release the enter button. The factory engineer's code is restored to 111111 (6 x 1)

TROUBLE SHOOTING

SYMPTOM	TEST
No speech from the door panel to the telephone.	Check terminal 2 on the amplifier for continuity to terminal 2 on the telephone.
	Check the voltage drops to approx. 1Vdc after the handset is lifted. (If not try another telephone)
	If all else fails try another amplifier at the door station
No speech from the telephone to the door panel.	Check terminal 1 on the door panel amplifier for continuity back to terminal 1 on the telephone.
	Check the voltage drops to approx. 4Vdc after the handset is lifted. (If not try another telephone)
	If all else fails try another amplifier at the door station
No speech in either direction	Check the 315mA fuse in the power supply
	Check for 12Vdc across terminals + & - on the door panel amplifier. This should be there all the time and comes directly from the PSU.
Lock will not operate from telephone	Check terminal 5 on the telephone. This terminal shorts to terminal 3 of the telephone when pressed (Becomes 0V) and sends a 0V to terminal 5 on the VX136 amplifier at the door panel which in turn triggers the relay
	Check the relay on the VX136 is energising. Use a continuity meter to check the switching.
Nothing happens when call button is pressed	Check the common of the button is connected to T on the VX136
	Check continuity from the other side of the call button to terminal 4 on the handset
Hum on the speech lines	Ensure all intercom cables do not run close to higher voltage cables
	Try another amplifier at the door panel.
Codelock not operating	Check power on terminals 1 & 2 on the codelock is 12V. If this voltage is lower it may not operate the relays correctly.
	Check the keys beep when pressed. This will not happen if the codelock is faulty or has the incorrect power connected to terminals 1 & 2
	Try re-programming the codelock



Northern Office

Videx Security Ltd
Unit 4-7 Chillingham Ind. Est.
Newcastle Upon Tyne
NE6 2XX
TEL 0870 300 1240
FAX 0191 224 5678

Southern Office

1 Osprey
Trinity Park
Trinity Way
London
E4 8TD
FAX 0208 523 5825

TECHNICAL SUPPORT

tech@videx-security.com
TEL 0191 224 3174
FAX 0191 224 4938
<http://www.videx-security.com>