

QCVK Series video door entry system 1 user (up to 4 monitors), 2 entrance panels

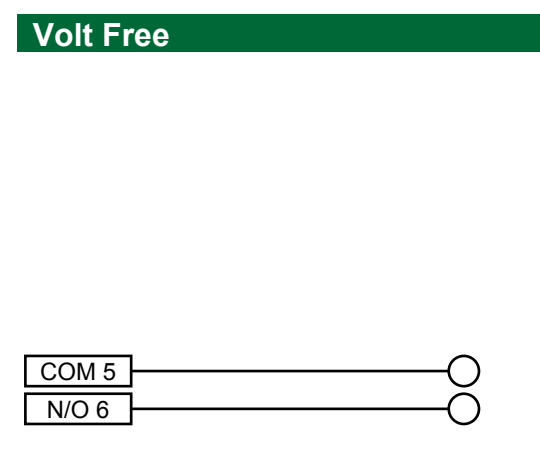

Locking Options
Note : Connections show additional power supply suitable for the lock release used

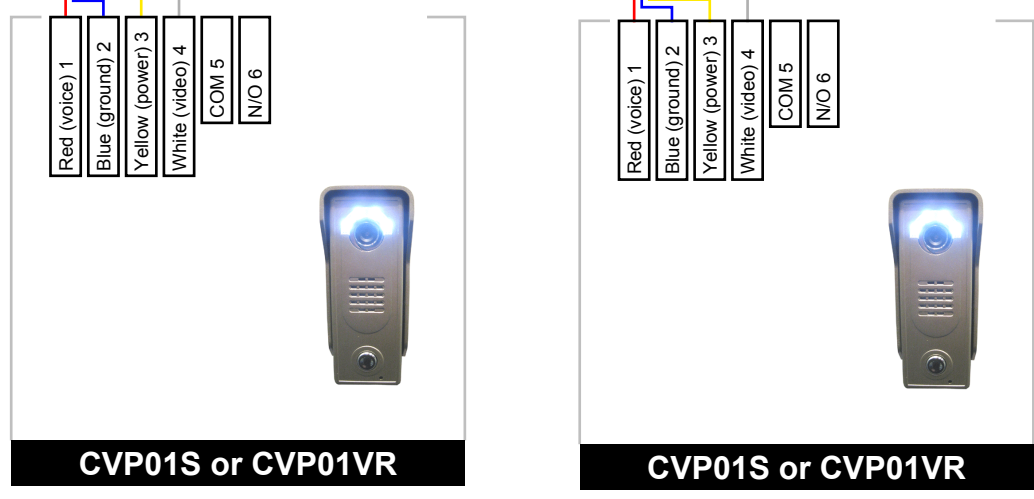
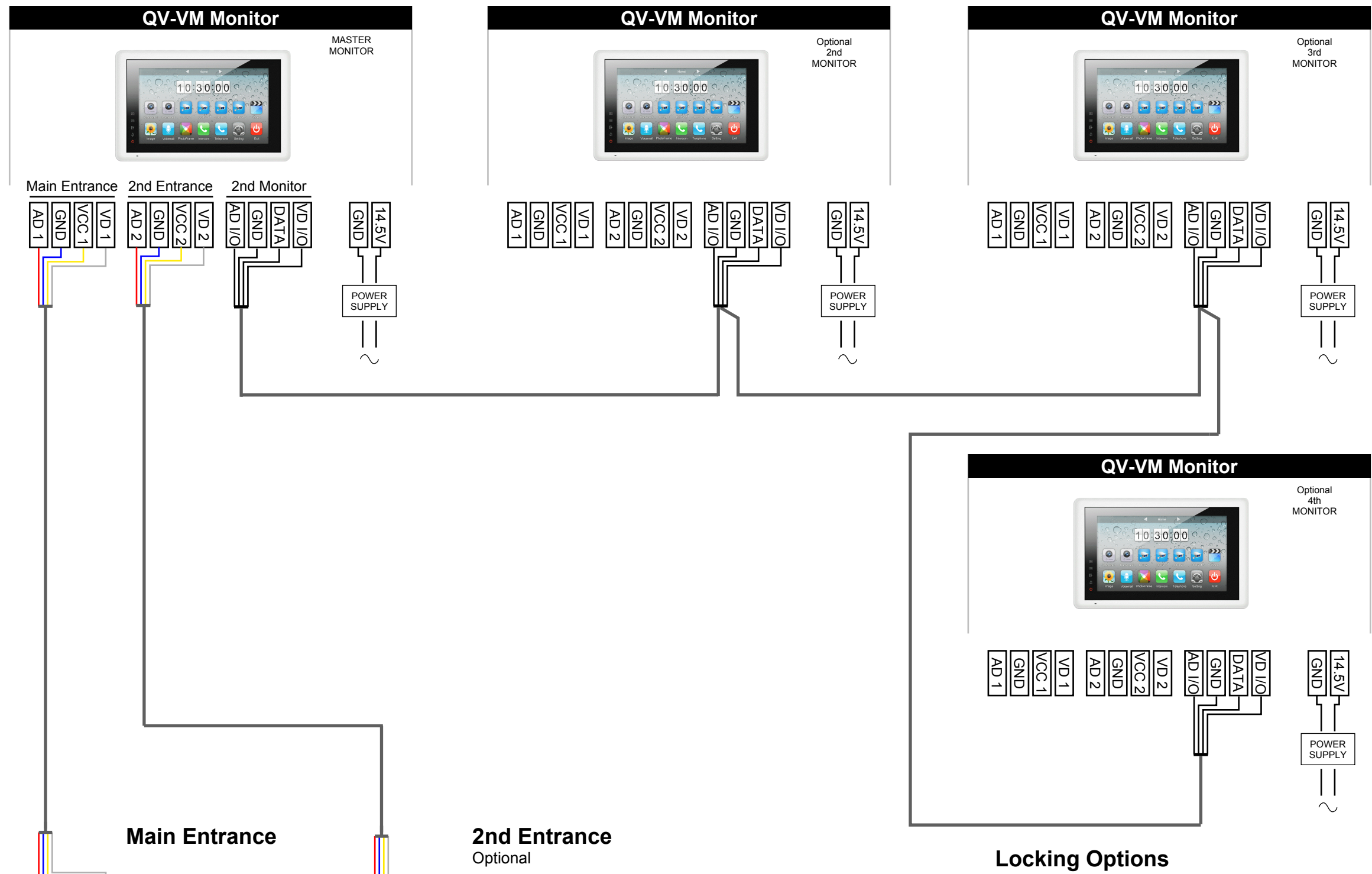
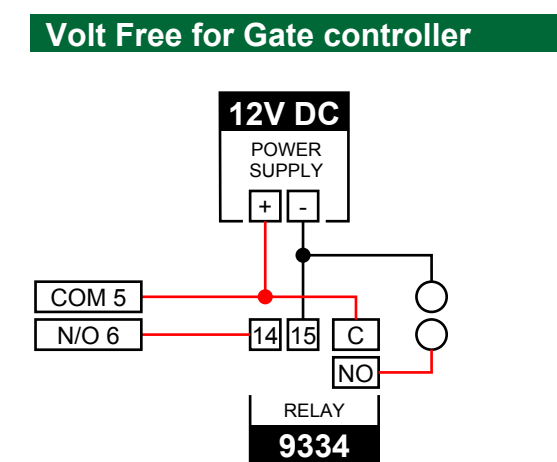
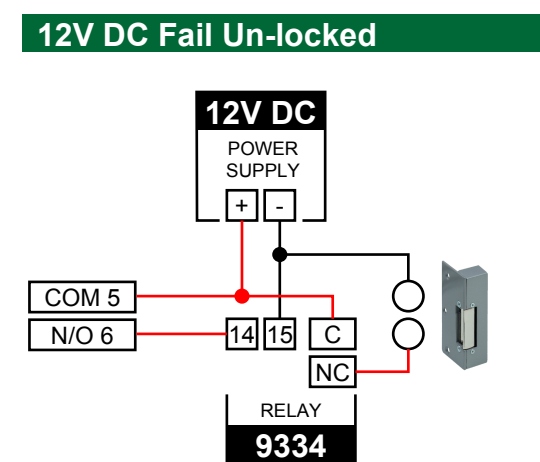
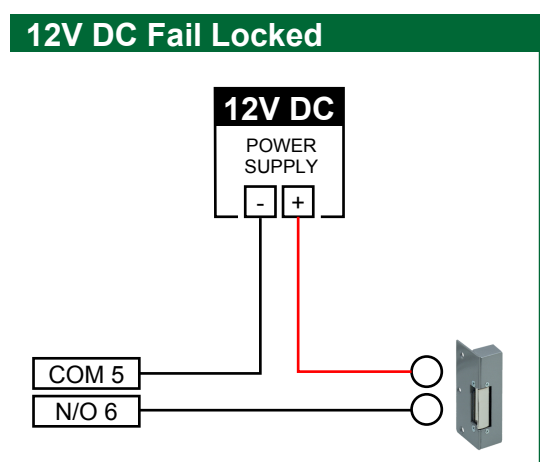

Installation Notes

Entrance Panel(s)
Ignore connections to 2nd entrance panel if not required.

Cable
Make sure that the cable used to power monitor is thick enough that the voltage you read at the power supply end is that same voltage that you read at the monitor end.

If using **CAT5E** or equivalent cable of **0.2mm** cross sectional area, **DO NOT EXCEED SPECIFIED DISTANCE FOR CORRECT SYSTEM OPERATION**

Power Supply - Monitor
Distance < 15 metres
2 core twisted pair per connection is required for correct operation



Door Station - Monitor (last monitor)
Distance < 50 metres
2 core twisted pair per connection is required for correct operation

