

Day/Night Vandal Proof Dome Camera

Crystal clear vandal resistant polycarbonate window

The high quality optically correct polycarbonate dome gives undistorted image production. The dome is made from vadal resistant polycarbonate, which protects the camera from even the most violent attack.

Excellent colour reproduction

This camera produces true and natural colour rendition. This is achieved using a combination of sophisticated hardware and software technology, including 1/3" CCD sensor and our own noise-free power circuit.

Live & vivid picture quality with enhanced video technology

Our own unique technology enables a normal CCD camera to provide extremely clear images. This camera technology also provides a higher resolution and better low lux sensitivity.

Removable dome cover

The dome cover protects the camera from contamination. It can be removed for maintenance purposes by turning the cover clockwise . If the dome cover gets scratched it can be easily changed.

Digital Day/Night

The image is instantly changed from Colour to B/W at 5 lux. Thanks to "Colour Killing Technology", horizontal and vertical resolution is greatly improved at night time and the low lux performance is improved a lot in monochrome.

Extremely Low Power Consumption

This camera operates on DC12V \pm 3V requires less than 90mA. It gives maximum reliability by producing less damaging heat.

Beautiful design & anti-scratch coating

The camera has a smart and elegant construction and design. It is a high quality product and the innovative "scratch free" coating keeps the camera looking good even in the harshest of environments.

Easy Installation

It's easy to adjust the dome's angle of view or the lens. The outer metal case unscrews to reveal the ball containing the camera, so it's easy to assemble and dissemble the dome.

Audio Available (Option)

High sensitive, very clear one way external audio is supplied with a flexible length of audio cable.

Reverse polarity power input protection is built in.

Key Features

- Micro Compact Size Dome
- Anti-Vandal Camera Body and Dome Cover
- 1/3" Sony Super HAD Colour CCD Sensor
- 400TVL (Standard Resolution) or 500 TVL (High Resolution)
- Remarkable Low Lux Performance of 0.2 Lux/F2.0
- Digital Day & Night
- Lens Options
- Beautiful Design
- Weatherproof (IP66)
- Reverse Image(Optional)

Dimension(mm)

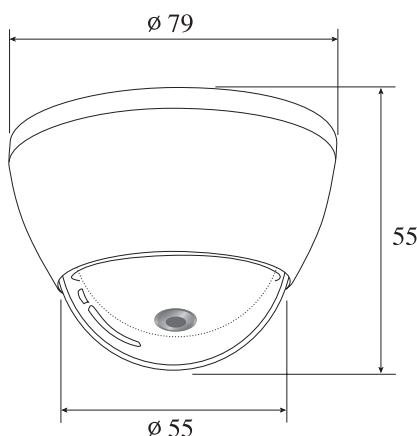

Connection

Option- lead wire : 4f	Red : DC12V IN
	Black : GND
	Yellow : Video in
	White : GND

Extension Cable Option

Standard	4f (1.2M)
Option	60f (18M)
	75f (25M)

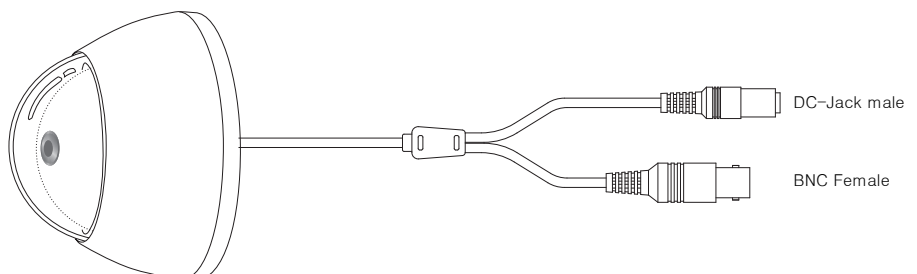

**Surface Mount
Mini Armoured Dome Camera
Digital Day/Night**

Specification

Model	MVD253C
Image sensor	1/3" Sony Super HAD CCD
Effective Pixels	NTSC : 512(H)X492(V) NTSC : 768(H)X494(V) PAL : 500(H)X582(V) PAL : 752(H)X582(V)
H.Resolution	400TVL(D)/420TVL(N) 500TVL(D)/560TVL(N)
Synchronising system	Internal
Scanning system	NTSC 525 Lines PAL 625 Lines 2:1 Interlaced
Video output	1.0Vp-p Composite. 75 Ohms
S/N ratio	More than 50 dB (AGC Off)
Min. Illumination	0.2 Lux at F2.0
BLC	Automatic
White balance	2100°K9100°K Auto
Gain Control	4dB~32dB Auto
Gamma correction	r=0.45
Smear effect	0.005%
Shutter speed	NTSC : 1/60~1/100,000 sec PAL : 1/50~1/100,000 sec
MTBF	80,000 hours
Power source	Regulated DC12V
Operation current	90mA w / regulated 12VDC power in
Lens	2.9mm (120°) 3.6mm (92°)/2.5mm(145°)
Option	4.3mm(78°), 6.0 mm (54°), 8.0mm (39°)
Operating Temperature	14° F~122° F (-10°C~ + 50°C)
Humidity	Within 90% RH
Output Terminal	1.2M DIY cable with
Cable connection	BNC-Female for Video, DC Jack-Male for Power
Measurement (mm)	79(D)X48(L)
Weight(Approx.g)	300
Optional feature	External Audio with C-Microphone " - 35dB / mV "