

MT CT 03

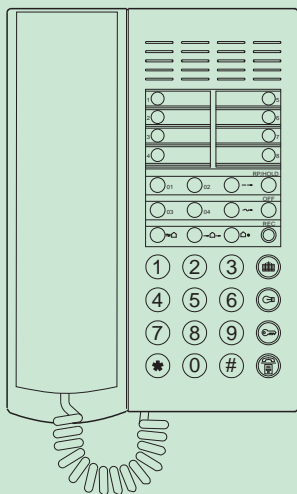

Istruzioni per l'uso del telefono COMTEL Art. 1926 - Tipologia d'uso n° 2-3
Derivato abbinato a centrale telefonica Art. 2906

Instructions for use of the COMTEL Telephone Art. 1926 - Type of use: n° 2-3
Operator branch combine with telephone switchboard Art. 2906

Instructions pour l'utilisation du Téléphone COMTEL Art. 1926 - Typologie d'usage n° 2-3
Appareil dérivé opérateur associé à la standard téléphonique Art. 2906

Instructies voor het gebruik van de COMTEL-telefoon art. 1926 - Gebruikstype nr. 2-3
Gebruikerstoestel voor telefooncentrale art. 2906

Instrucciones para el uso del teléfono COMTEL Art. 1926 - Tipología de uso n° 2
Derivado combinado a central telefónica Art. 2906

07-2006

TELEFONO COMTEL. TIPOLOGIA D'USO N° 2: DERIVATO POSTO OPERATORE

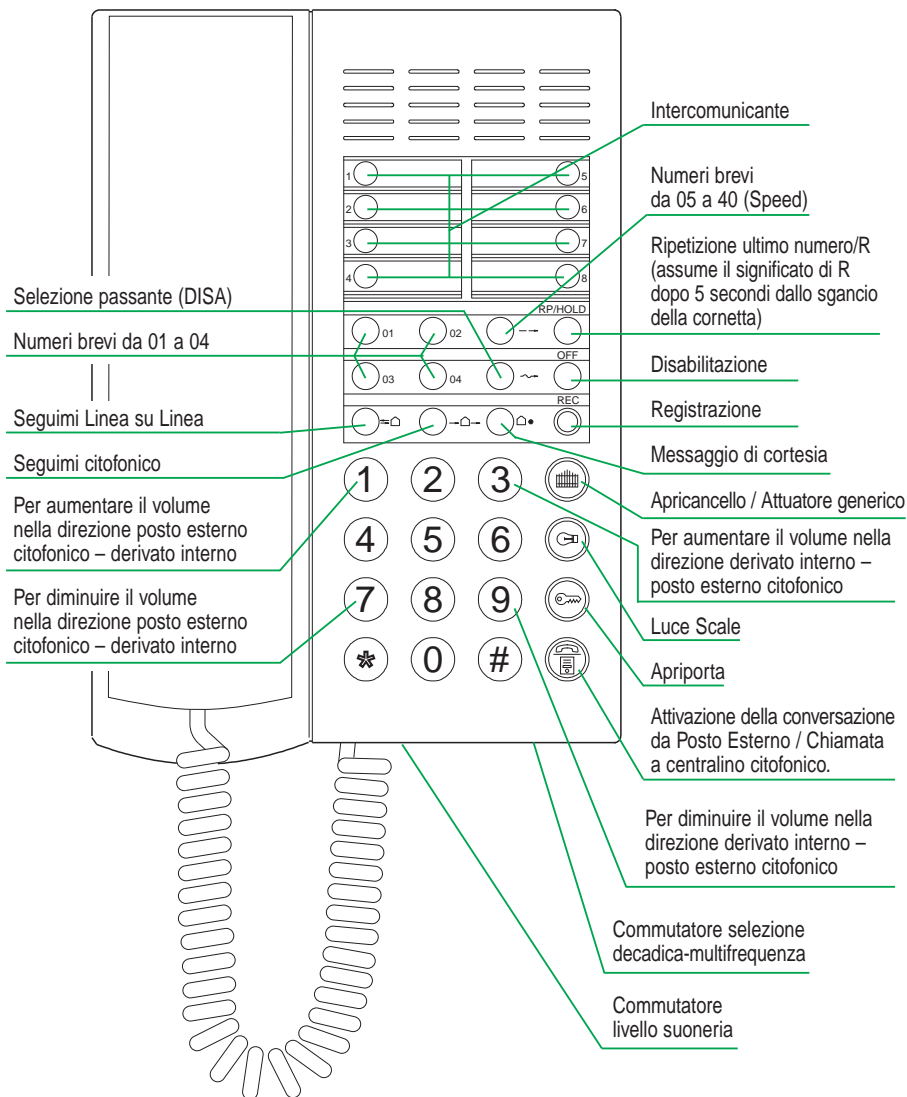

SCELTA DELLA TIPOLOGIA

Il telefono COMTEL Art. 1926 si presta per 3 funzioni diverse, qui di seguito descritte:

- 1** Derivato posto operatore, abbinato alla centrale telefonica Art. 1906.
- 2** Derivato posto operatore, abbinato alla centrale telefonica Art. 2906.
- 3** Derivato utente normale, abbinato alla centrale telefonica Art. 2906.

La scelta della tipologia avviene posizionando il commutatore posto sul retro (vedi figura), inserendo l'etichetta legenda appropriata e configurando la centrale telefonica come da manuale (rif. manuale MT CT 01 appendice A parametro 20).

Questa sezione del manuale descrive solamente le funzioni della tipologia **2**. Per ulteriori funzioni si rimanda al manuale a corredo della centrale telefonica.

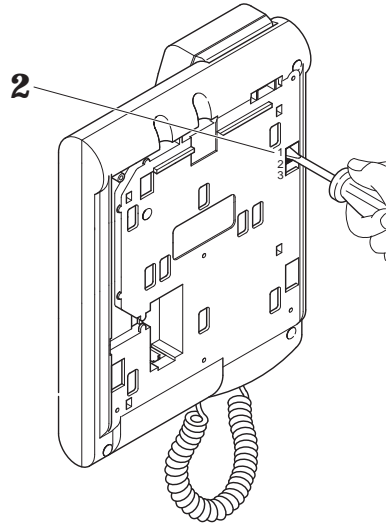

FUNZIONI

Per effettuare una chiamata telefonica

 Alzo cornetta	 Tono continuo	 Tasto 0	 Tono di linea	esempio Numero telefonico
-------------------	-------------------	-------------	-------------------	----------------------------------





Intercomunicante

 Alzo cornetta	 Tono continuo	 Tasto intercomunicante 1...8	 Il derivato chiamato squilla	 Conversazione
-------------------	-------------------	----------------------------------	----------------------------------	-------------------

Chiamata numeri brevi

 Alzo cornetta	 Tono continuo	 Tasto numero breve (01...04)	 Il telefono remoto squilla	 Conversazione
-------------------	-------------------	----------------------------------	--------------------------------	-------------------

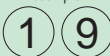
Chiamata numeri brevi 05...40

 Alzo cornetta	 Tono continuo	 Tasto SPEED	esempio  Numero breve (es.19)	 Il telefono remoto squilla	 Conversazione
---	--	--	--	---	--

Ripetizione ultimo numero

 Alzo cornetta	 Tono continuo	RP/HOLD  Ripetizione ultimo numero
---	--	---

Luci Scale (valido per centrale 2906 equipaggiata con scheda 2909)

 Alzo cornetta	 Tono continuo	 Tasto luci scale	 Tono conferma
---	--	---	--

Apriporta

 Alzo cornetta	 Tono continuo	 Tasto apriporta	 Tono conferma
---	--	--	--

Apricancello (valido per centrale 2906 equipaggiata con scheda 2909)

 Alzo cornetta	 Tono continuo	 Tasto apricancello	 Tono conferma
---	--	---	--

Attuatore generico (valido per centrale 2906 equipaggiata con scheda 2912)

 Alzo cornetta	 Tono continuo	 Tasto apricancello	 Tono conferma
---	--	---	--

Attivazione della conversazione da Posto Esterno (valido per centrale 2906 equipaggiata con scheda 2909)

 Alzo cornetta	 Tono continuo	 Conversazione citofonica	 Conversazione
---	--	---	--

Chiamata a centralino citofonico Simplebus (valido per centrale 2906 equipaggiata con scheda 2912)

 Alzo cornetta	 Tono continuo	 Conversazione citofonica	 Tono conferma
---	--	---	--

Luci Scale su chiamata citofonica (valido per centrale 2906 equipaggiata con scheda 2909)

 Chiamata citofonica	 Alzo cornetta	 Conversazione citofonica	 Tasto luci scale	 Tono conferma
--	--	---	---	--

Apriporta su chiamata citofonica

 Chiamata citofonica	 Alzo cornetta	 Conversazione citofonica	 Tasto apriporta	 Tono conferma
--	--	---	--	--







Apricancello / Attuatore su chiamata citofonica

 Chiamata citofonica	 Alzo cornetta	 Conversazione citofonica	 Tasto apricancello	 Tono conferma
--	--	---	---	--

Messa in attesa di una conversazione telefonica

 Conversazione telefonica	RP/HOLD  Messa in attesa	 Tono continuo	 Musica in linea
---	---	--	--



Chiamata citofonica durante una conversazione telefonica

 Conversazione telefonica	 Tono di avviso	RP/HOLD   Risposta a chiamata citofonica	 Conversazione citofonica	 Musica in linea
---	---	--	---	--

Chiamata telefonica durante una conversazione citofonica

 Conversazione citofonica	 Tono di avviso	RP/HOLD   Risposta a chiamata citofonica	 Conversazione telefonica
---	---	--	---

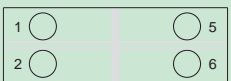
Deviazione di una chiamata telefonica su un altro telefono derivato

 Conversazione telefonica	 Tasto intercomunicante 1...8	 Musica in linea	 Il derivato chiamato squilla
---	---	--	---





Comandi speciali Simplebus (valido per centrale 2906 equipaggiata con scheda aggiuntiva 2912)

 Alzo cornetta	 Tono continuo	  X X = cifra da 1 a 8	 Tono conferma
--	--	---	--





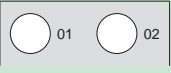

PROGRAMMAZIONE

NUMERI BREVI

Registrazione numeri brevi da 01 a 04

		REC 		esempio 	# Fine registrazione 
Alzo cornetta	Tono continuo	Tasto REC	Tasto numero breve (01...04)	Numero telefonico	Tono conferma

Registrazione numeri brevi da 05 a 40

		REC 	esempio 	esempio 	# Fine registrazione 
Alzo cornetta	Tono continuo	Tasto REC	Numero breve (es. 19)	Numero telefonico	Tono conferma

MESSAGGIO DI CORTESIA

Abilitazione messaggio di cortesia

			
Alzo cornetta	Tono continuo	Tasto cortesia	Tono conferma

Disabilitazione messaggio di cortesia

		OFF 		
Alzo cornetta	Tono continuo	Tasto OFF	Tasto cortesia	Tono conferma

Registrazione messaggio di cortesia

		REC 		 Parametro Notte/Giorno Esempio: Notte	
Alzo cornetta	Tono continuo	Tasto REC	Tasto cortesia	Registrazione messaggio	

# Fine registrazione	
	Tono conferma

SEGUIMI CITOFONICO (FOLLOW-ME)

Abilitazione Seguimi citofonico

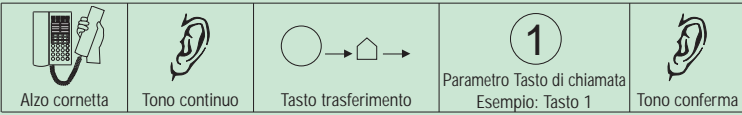

Disabilitazione Seguimi citofonico

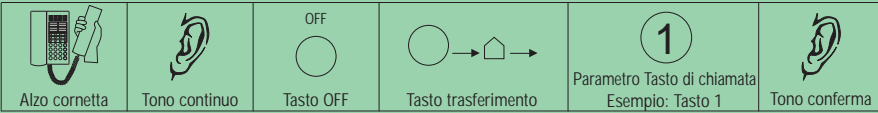

SEGUIMI LINEA SU LINEA (con 2 linee telefoniche)

Abilitazione Seguimi Linea su Linea



Disabilitazione Seguimi Linea su Linea

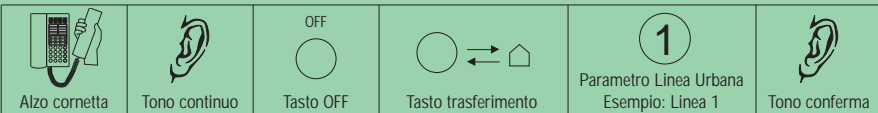

SELEZIONE PASSANTE (DISA)

Abilitazione selezione passante



Disabilitazione selezione passante



Registrazione messaggio per selezione passante



TELEFONO COMTEL. TIPOLOGIA D'USO N° 3: DERIVATO UTENTE NORMALE

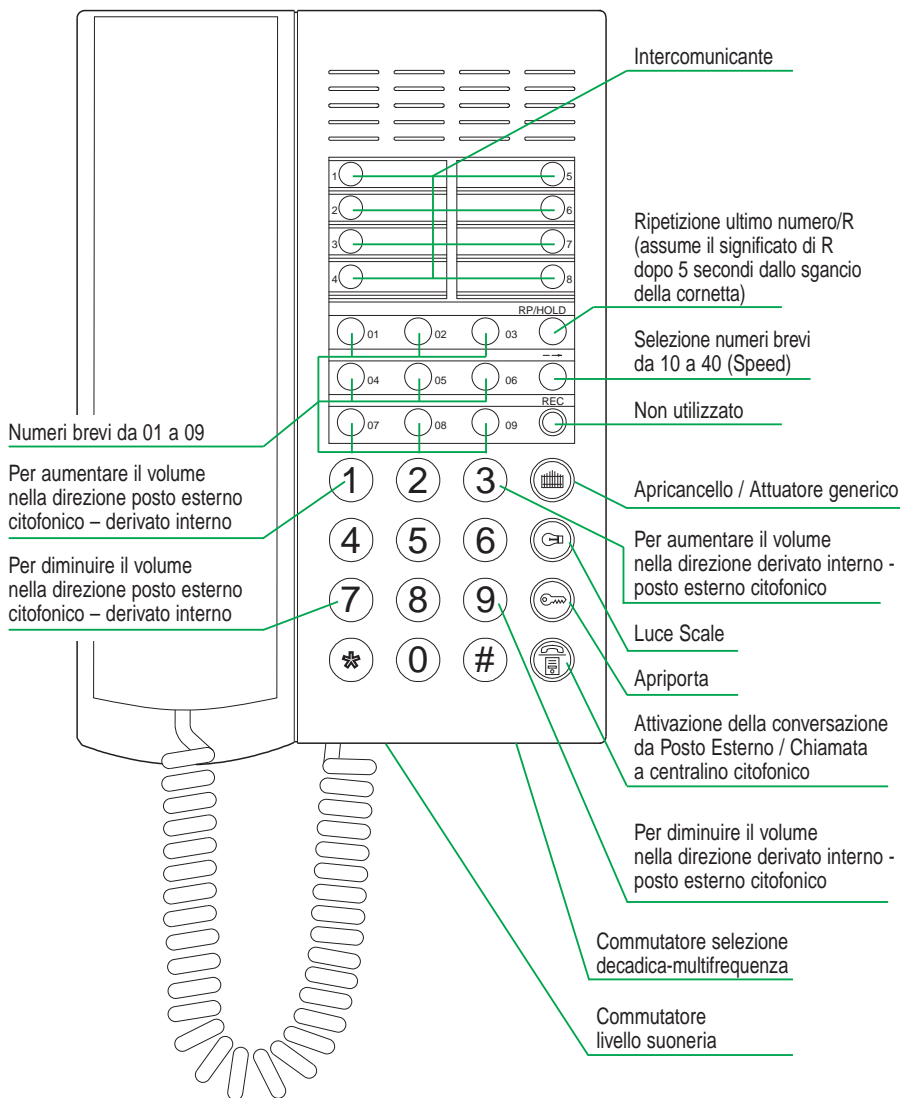

SCELTA DELLA TIPOLOGIA

Il telefono COMTEL Art. 1926 si presta per 3 funzioni diverse, qui di seguito descritte:

- 1** Derivato posto operatore, abbinato alla centrale telefonica Art. 1906.
- 2** Derivato posto operatore, abbinato alla centrale telefonica Art. 2906.
- 3** Derivato utente normale, abbinato alla centrale telefonica Art. 2906.

La scelta della tipologia avviene posizionando il commutatore posto sul retro (vedi figura), inserendo l'etichetta legenda appropriata e configurando la centrale telefonica come da manuale (rif. manuale MT CT 01 appendice A parametro 20).

Questa sezione del manuale descrive solamente le funzioni della tipologia **3**. Per ulteriori funzioni si rimanda al manuale a corredo della centrale telefonica.

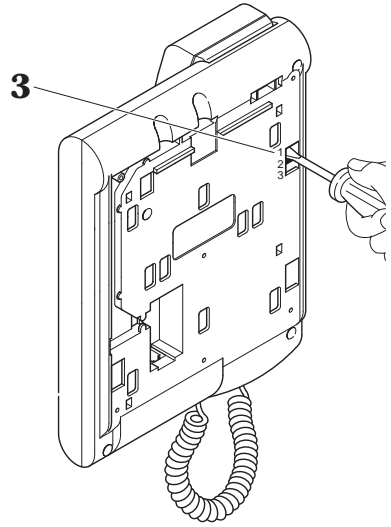

FUNZIONI

Per effettuare una chiamata telefonica





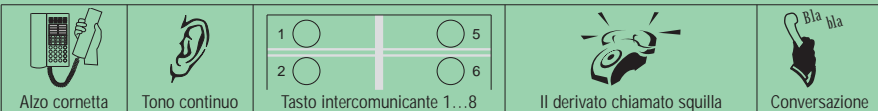

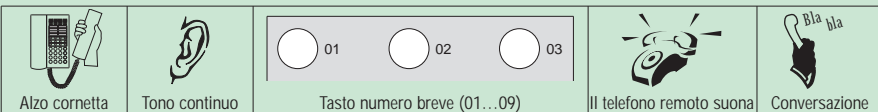

Intercomunicante



Chiamata numeri brevi 01...09



Chiamata numeri brevi 10...40

 Alzo cornetta	 Tono continuo	 Tasto SPEED	esempio   Numero breve (es.19)	 Il telefono remoto suona	 Conversazione
---	--	--	--	---	--

Ripetizione ultimo numero

 Alzo cornetta	 Tono continuo	RP/HOLD  Ripetizione ultimo numero
---	--	---

Luci Scale (valido per centrale 2906 equipaggiata con scheda 2909)

 Alzo cornetta	 Tono continuo	 Tasto luci scale	 Tono conferma
---	--	---	--

Apriporta

 Alzo cornetta	 Tono continuo	 Tasto apriporta	 Tono conferma
---	--	--	--

Apricancello (valido per centrale 2906 equipaggiata con scheda 2909)

 Alzo cornetta	 Tono continuo	 Tasto apricancello	 Tono conferma
---	--	---	--

Attuatore generico (valido per centrale 2906 equipaggiata con scheda 2912)

 Alzo cornetta	 Tono continuo	 Tasto apricancello	 Tono conferma
---	--	---	--

Attivazione della conversazione da Posto Esterno (valido per centrale 2906 equipaggiata con scheda 2909)

 Alzo cornetta	 Tono continuo	 Conversazione citofonica	 Conversazione
---	--	---	--

Chiamata a centralino citofonico Simplebus (valido per centrale 2906 equipaggiata con scheda 2912)

 Alzo cornetta	 Tono continuo	 Conversazione citofonica	 Tono conferma
---	--	---	--

Luci Scale su chiamata citofonica (valido per centrale 2906 equipaggiata con scheda 2909)

 Chiamata citofonica	 Alzo cornetta	 Conversazione citofonica	 Tasto luci scale	 Tono conferma
--	--	---	---	--

Apriporta su chiamata citofonica

 Chiamata citofonica	 Alzo cornetta	 Conversazione citofonica	 Tasto apriporta	 Tono conferma
--	--	---	--	--







Apricancello / Attuatore su chiamata citofonica

 Chiamata citofonica	 Alzo cornetta	 Conversazione citofonica	 Tasto apricancello	 Tono conferma
--	--	---	---	--

Messa in attesa di una conversazione telefonica

 Conversazione telefonica	RP/HOLD  Messa in attesa	 Tono continuo	 Musica in linea
---	---	--	--



Chiamata citofonica durante una conversazione telefonica

 Conversazione telefonica	 Tono di avviso	RP/HOLD   Risposta a chiamata citofonica	 Conversazione citofonica	 Musica in linea
---	---	--	---	--

Chiamata telefonica durante una conversazione citofonica

 Conversazione citofonica	 Tono di avviso	RP/HOLD   Risposta a chiamata telefonica	 Conversazione telefonica
---	---	--	---

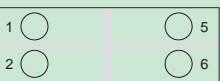
Deviazione di una chiamata telefonica su un altro telefono

 Conversazione telefonica	 Tasto intercomunicante 1...8	 Musica in linea	 Il derivato chiamato squilla
---	---	--	---

Comandi speciali Simplebus (valido per centrale 2906 equipaggiata con scheda aggiuntiva 2912)

 Alzo cornetta	 Tono continuo	  X X = cifra da 1 a 8	 Tono conferma
--	--	---	--

COMTEL TELEPHONE. TYPE OF USE: N° 2: OPERATOR BRANCH

ENGLISH

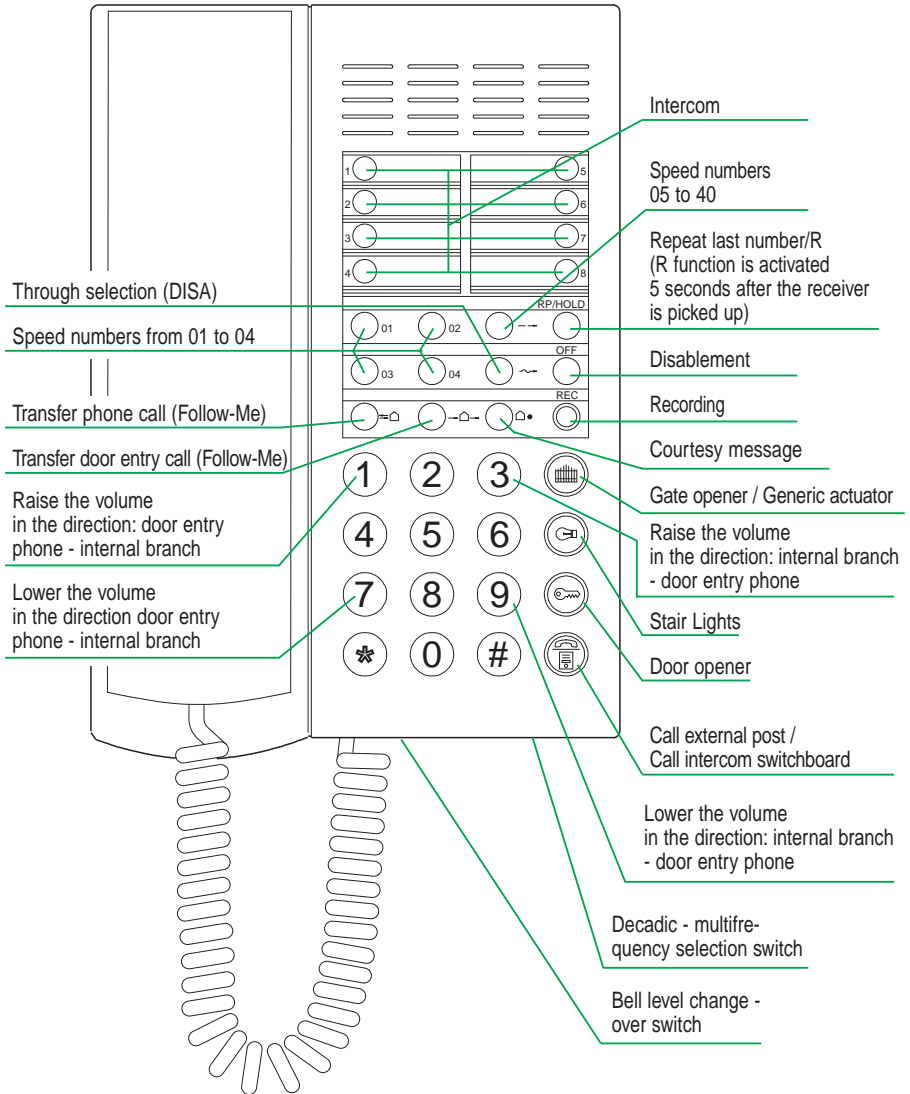

SELECTION OF THE TYPE

The COMTEL Telephone Art. 1926 door entry phone can be used for 3 different functions, as described below:

- 1** Operator branch, combined with telephone switchboard Art. 1906.
- 2** Operator branch, combined with telephone switchboard Art. 2906.
- 3** User branch, combined with telephone switchboard Art. 2906.

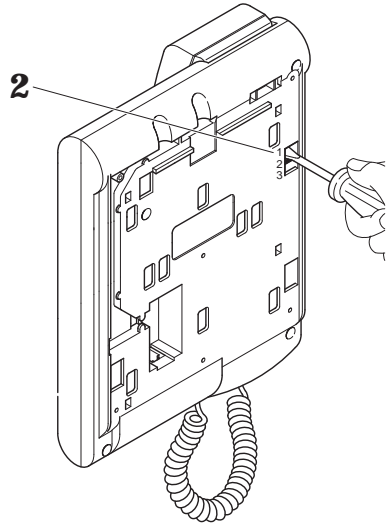

The type is selected by positioning the change-over switch on the rear (see figure), inserting the appropriate caption label and configuring the telephone switchboard as indicated in the manual (refer to manual MT/CT/01 appendix A parameter 20.)

This manual only describes the functions for type 2. For other functions, please consult the manual provided with the telephone switchboard.

FUNCTIONS

To make a telephone call

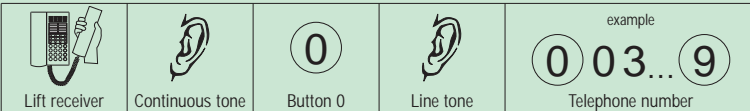



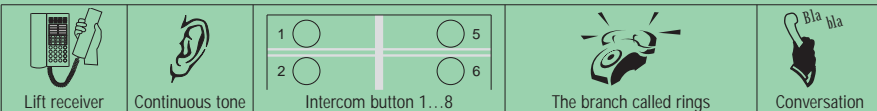

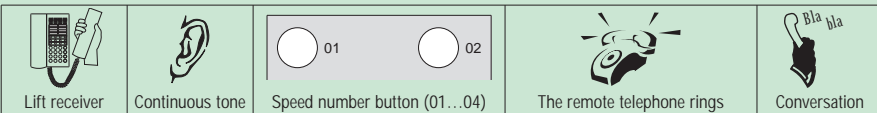

Intercom call



Calling speed numbers







Calling speed numbers 05...40

 Lift receiver	 Continuous tone	 SPEED button	example  Speed number (e.g. 19)	 The remote telephone rings	 Conversation
---	--	---	--	---	---





Repeat last number

 Lift receiver	 Continuous tone	RP/HOLD  Repeat last number
---	--	--





Stair Lights (valid for switchboard Art. 2906 equipped with circuit board Art. 2909)

 Lift receiver	 Continuous tone	 Stair lights button	 Confirmation tone
---	--	--	--





Door opener

 Lift receiver	 Continuous tone	 Door opening button	 Confirmation tone
---	--	--	--

Gate opener (valid for switchboard Art. 2906 equipped with circuit board Art. 2909)

 Lift receiver	 Continuous tone	 Gate opening button	 Confirmation tone
---	--	--	--

Generic actuator (valid for switchboard Art. 2906 equipped with circuit board Art. 2912)

 Lift receiver	 Continuous tone	 Gate opening button	 Confirmation tone
---	--	--	--

Call external post (valid for switchboard Art. 2906 equipped with circuit board Art. 2909)

 Lift receiver	 Continuous tone	 Call external post button	 Conversation with door entry phone
---	--	--	---

Call Simplebus central porter switchboard (valid for switchboard Art. 2906 equipped with circuit board Art. 2912)

 Lift receiver	 Continuous tone	 Call Simplebus button	 Confirmation tone
---	--	--	--

Stair Lights on door entry call (valid for switchboard Art. 2906 equipped with circuit board Art. 2909)

 Door entry phone call	 Lift receiver	 Door entry phone conversation	 Stair lights button	 Confirmation tone
--	--	--	--	--

Door opening on door entry call

 Door entry phone call	 Lift receiver	 Door entry phone conversation	 Door opening button	 Confirmation tone
--	--	--	--	--





Gate opener / Actuator on door entry call

 Door entry phone call	 Lift receiver	 Door entry phone conversation	 Gate opening button	 Confirmation tone
--	--	--	--	--





Putting a telephone conversation on hold

 Telephone conversation	RP/HOLD  Putting on hold	 Continuous tone	 Music on line
---	---	--	--



Door entry call during a telephone conversation

 Telephone conversation	 Warning tone	RP/HOLD  2 Answer a door entry phone call	 Door entry phone conversation	 Music on line
---	---	--	--	--

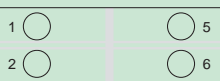

Telephone call during a door entry conversation

 Door entry phone conversation	 Warning tone	RP/HOLD  2 Answer a door entry phone call	 Telephone conversation
--	---	--	---

Branching a telephone call onto another telephone extension

 Telephone conversation	 Intercom button 1..8	 Music on line	 The extension called rings
---	---	--	---





Simplebus special commands (valid for switchboard Art. 2906 equipped with circuit board Art. 2912)

 Lift receiver	 Continuous tone	8 5 X X = a number from 1 to 8	 Confirmation tone
--	--	-----------------------------------	--





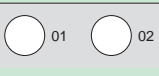

PROGRAMMING

SPEED NUMBERS

Recording speed numbers from 01 to 04





		REC 		example 	# End of recording	
Lift receiver	Continuous tone	REC button	Speed number (01...04)	Telephone number	End of recording	Confirmation tone

Recording speed numbers from 05 to 40





		REC 	esempio 	example 	# End of recording	
Lift receiver	Continuous tone	REC button	Speed number (es 19)	Telephone number	End of recording	Confirmation tone

COURTESY MESSAGE







Enable courtesy message

			
Lift receiver	Continuous tone	Courtesy button	Confirmation tone

Disable courtesy message

		OFF 		
Lift receiver	Continuous tone	OFF button	Courtesy button	Confirmation tone

Record courtesy message

		REC 		 Night/Day parameter Example: Night	
Lift receiver	Continuous tone	REC button	Courtesy button	Message recording	

# End of recording	 End of recording tone
-----------------------	--

TRANSFER A CALL FROM DOOR ENTRY PHONE (FOLLOW-ME)

Enable transfer door entry call

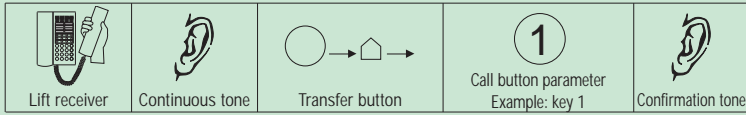

Disable transfer door entry call

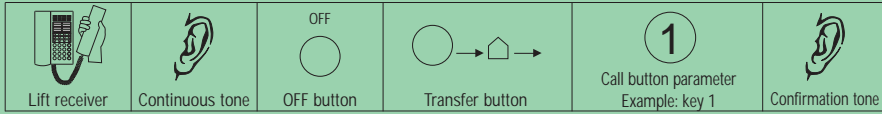

TRANSFER A PHONE CALL (switchboard with 2 telephone lines)

Enable transfer phone call

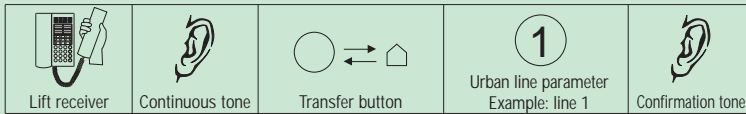

Disable transfer phone call

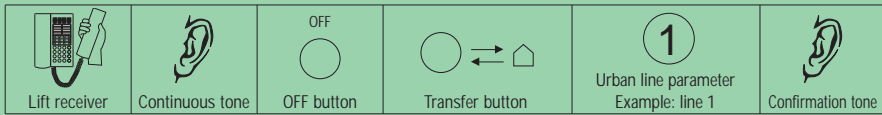

THROUGH SELECTION (DISA)

Enabling DISA

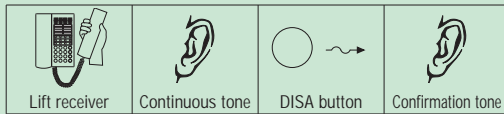

Disabling DISA

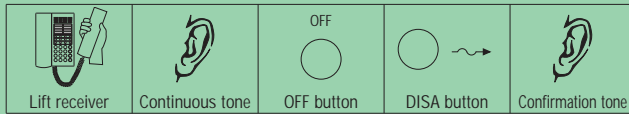

Recording DISA message

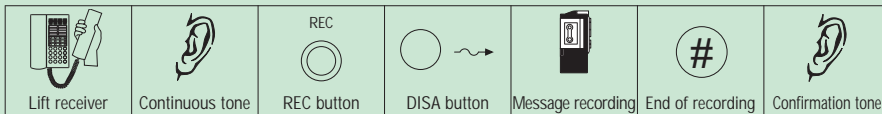

COMTEL TELEPHONE. TYPE OF USE: N° 3: USER BRANCH

ENGLISH

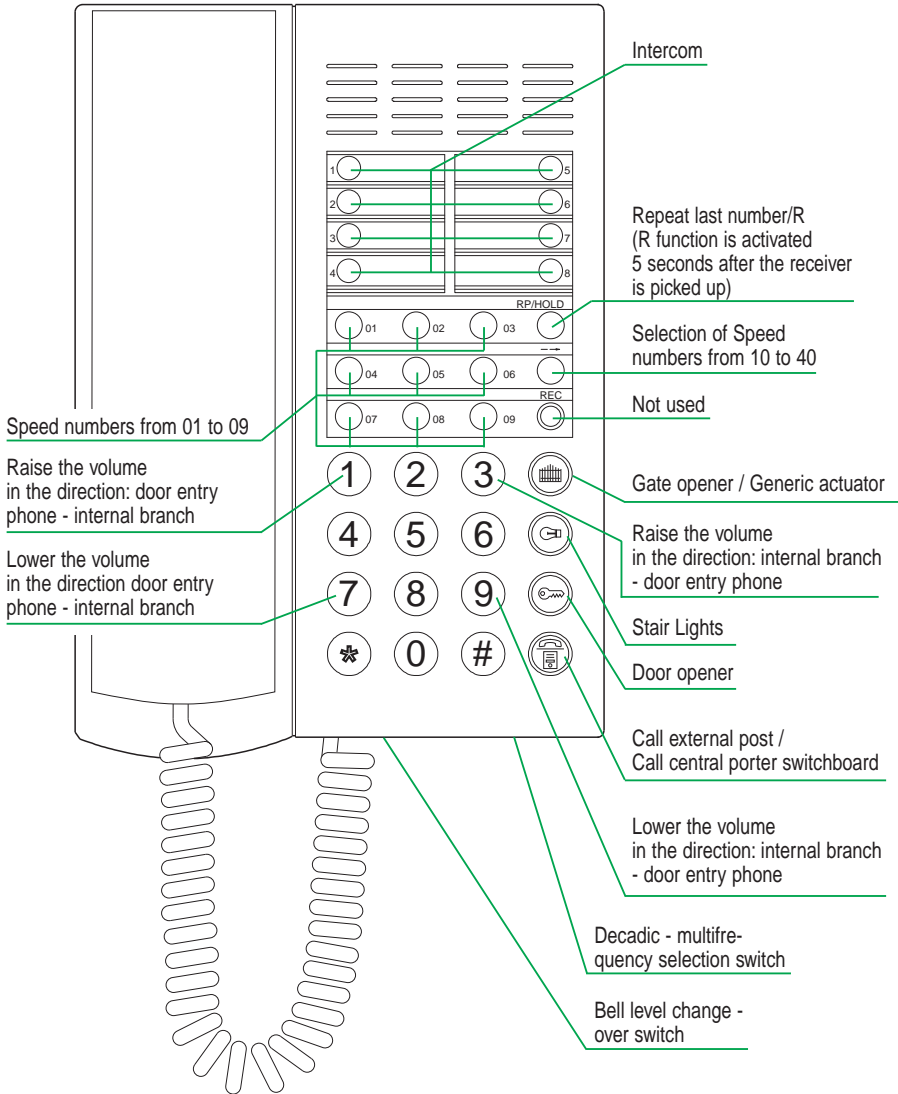

SELECTION OF THE TYPE

The COMTEL Telephone Art. 1926 door entry phone can be used for 3 different functions, as described below:

- 1** Operator branch, combined with telephone switchboard Art. 1906.
- 2** Operator branch, combined with telephone switchboard Art. 2906.
- 3** User branch, combined with telephone switchboard Art. 2906.

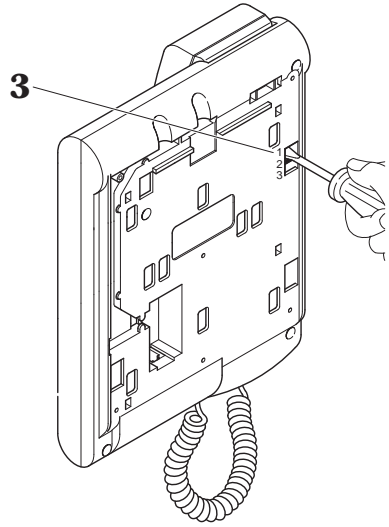

The type is selected by positioning the change-over switch on the rear (see figure), inserting the appropriate caption label and configuring the telephone switchboard as indicated in the manual (refer to manual MT/CT/01 appendix A parameter 20).

This manual only describes the functions for type 3. For other functions, please consult the manual provided with the telephone switchboard.

FUNCTIONS

To make a telephone call

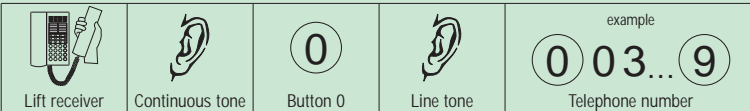



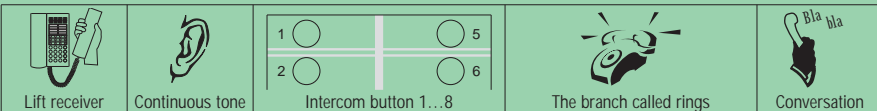

Intercom

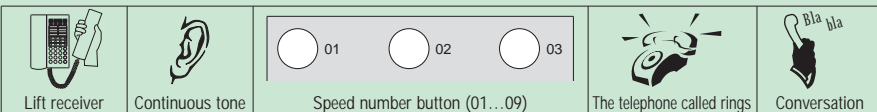

Calling speed numbers 01...09



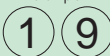



Calling speed numbers 10...40

 Lift receiver	 Continuous tone	 SPEED button	example  Speed number (e.g. 19)	 The telephone called rings	 Conversation
---	--	---	--	---	---





Repeat last number

 Lift receiver	 Continuous tone	RP/HOLD  Repeat last number
---	--	--





Stair Lights (valid for switchboard Art. 2906 equipped with circuit board Art. 2909)

 Lift receiver	 Continuous tone	 Stair lights button	 Confirmation tone
---	--	--	--





Door opener

 Lift receiver	 Continuous tone	 Door opening button	 Confirmation tone
---	--	--	--

Gate opener (valid for switchboard Art. 2906 equipped with circuit board Art. 2909)

 Lift receiver	 Continuous tone	 Gate opening button	 Confirmation tone
---	--	--	--

Generic actuator (valid for switchboard Art. 2906 equipped with circuit board Art. 2912)

 Lift receiver	 Continuous tone	 Gate opening button	 Confirmation tone
---	--	--	--

Call external post (valid for switchboard Art. 2906 equipped with circuit board Art. 2909)

 Lift receiver	 Continuous tone	 External post button	 Door entry phone conversation
---	--	---	--

Call Simplebus central porter switchboard (valid for switchboard Art. 2906 equipped with circuit board Art. 2912)

 Lift receiver	 Continuous tone	 Simplebus button	 Confirmation tone
---	--	---	--

Door opening on door entry call (valid for switchboard Art. 2906 equipped with circuit board Art. 2909)

 Door entry phone call	 Lift receiver	 Door entry phone conversation	 Door opening button	 Confirmation tone
--	--	--	--	--





Gate opening on door entry phone call

 Door entry phone call	 Lift receiver	 Door entry phone conversation	 Gate opening button	 Confirmation tone
--	--	--	--	--





Gate opener / Actuator on door entry call

 Door entry phone call	 Lift receiver	 Door entry phone conversation	 Gate opening button	 Confirmation tone
--	--	--	--	--





Putting a telephone conversation on hold

 Telephone conversation	RP/HOLD  Putting on hold	 Continuous tone	 Music on line
---	---	--	--



Door entry call during a telephone conversation

 Telephone conversation	 Warning tone	RP/HOLD  Answer a door entry phone call	 Telephone conversation	 Music on line
---	---	--	---	--

Telephone call during a door entry conversation

 Door entry phone conversation	 Warning tone	RP/HOLD  Answer a door entry phone call	 Telephone conversation
--	---	--	---

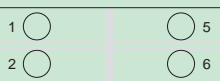
Branching a telephone call onto another telephone extension

 Telephone conversation	 Intercom button 1..8	 Music on line	 The extension called rings
---	---	--	---

Simplebus special commands (valid for switchboard Art. 2906 equipped with circuit board Art. 2912)

 Lift receiver	 Continuous tone	 X = a number from 1 to 8	 Confirmation tone
--	--	---	--

TELEPHONE COMTEL. TYPOLOGIE D'USAGE N° 2: APPAREIL DERIVE OPERATEUR

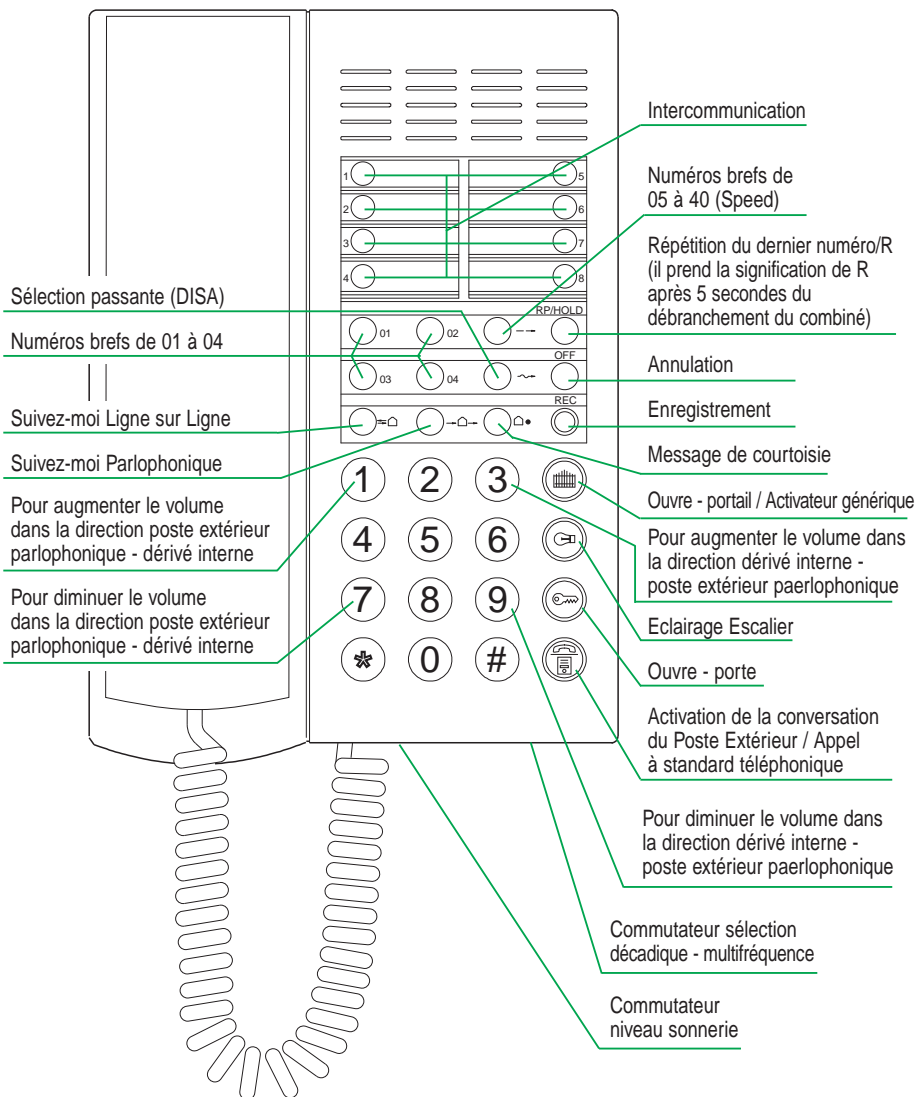

CHOIX DE LA TYPOLOGIE

Le Téléphone COMTEL Art. 1926 réalise les 3 fonctions décrites ci-dessous:

- 1** Appareil dérivé opérateur, associé à la standard téléphonique Art. 1906.
- 2** Appareil dérivé opérateur, associé à la standard téléphonique Art. 2906.
- 3** Appareil dérivé usager, associé à la standard téléphonique Art. 2906.

Pour choisir la typologie désirée, intervenir sur le commutateur situé sur le dos du téléphone (voir figure), mettre en place l'étiquette légende appropriée et configurer la centrale téléphonique comme décrit dans le manuel (Réf manuel MT/CT/01 annexe A paramètre 20).

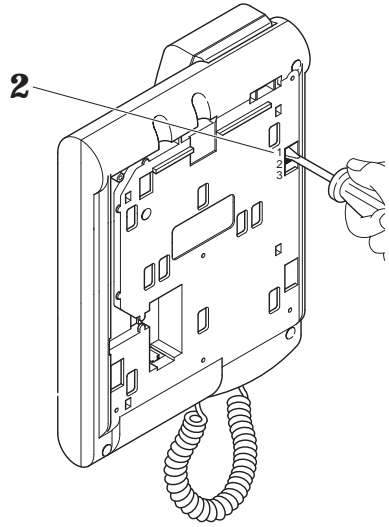

Le présent manuel décrit uniquement les fonctions de la typologie **2**. Pour les autres fonctions, consulter le manuel fourni avec la centrale téléphonique.

FRANÇAIS

FONCTIONS

Pour effectuer un appel téléphonique

				exemple
Décrocher le récepteur	Tonalité continue	Touche 0	Tonalité de ligne	Numéro de téléphone







Intercommunication

Décrocher le récepteur	Tonalité continue	Touche intercommunication 1...8	L'appareil dérivé appelé sonne	Conversation

Appel numéros brefs

Décrocher le récepteur	Tonalité continue	Touche numéro bref (01...04)	Le téléphone à distance sonne	Conversation

Appel numéros brefs 05...40

			exemple  		
Décrocher le récepteur	Tonalité continue	Touche SPEED	Numéro bref (ex. 19)	Le téléphone à distance sonne	Conversation

Répétition dernier numéro

		RP/HOLD 
Décrocher le récepteur	Tonalité continue	Répétition du dernier numéro

Eclairage Escalier (valable pour standard 2906 équipée avec carte 2909)

			
Décrocher le récepteur	Tonalité continue	Touche éclairage escalier	Tonalité confirmation

Ouvre-porte

			
Décrocher le récepteur	Tonalité continue	Touche ouvre-porte	Tonalité confirmation

Ouvre-portail (valable pour standard 2906 équipée avec carte 2909)

			
Décrocher le récepteur	Tonalité continue	Touche ouvre-portail	Tonalité confirmation

Activateur générique (valable pour standard 2906 équipée avec carte 2912)

			
Décrocher le récepteur	Tonalité continue	Touche ouvre-portail	Tonalité confirmation





Activation de la conversation du Poste Extérieur (valable pour standard 2906 équipée avec carte 2909)

			
Décrocher le récepteur	Tonalité continue		Conversation parlophonique

Appel à standard Simplebus (valable pour standard 2906 équipée avec carte 2912)

			
Décrocher le récepteur	Tonalité continue		Tonalité confirmation

Eclairage Escalier sur appel du poste extérieur (valable pour standard 2906 équipée avec carte 2909)

 Appel du poste extérieur	 Décrocher le récepteur	 Conversation	 Touche éclairage escalier	 Tonalité confirmation
---	---	---	--	--

Ouvre-porte sur appel du poste extérieur

 Appel du poste extérieur	 Décrocher le récepteur	 Conversation	 Touche ouvre-porte	 Tonalité confirmation
---	---	---	---	--







Ouvre - portail / Activateur sur appel parlophonique

 Appel du poste extérieur	 Décrocher le récepteur	 Conversation	 Touche ouvre-portail	 Tonalité confirmation
---	---	---	---	--





Mise en attente d'une conversation téléphonique

 Conversation téléphonique	RP/HOLD  Touche Mise en attente	 Tonalité continue	 Mélodie en ligne
--	--	--	---



Appel du poste extérieur durant une conversation téléphonique

 Conversation téléphonique	 Tonalité d'avertissement	RP/HOLD   Réponse à appel parlophonique	 Conversation	 Mélodie en ligne
--	---	---	---	---

Appel téléphonique durant une conversation avec le poste extérieur

 Conversation avec le poste extérieur	 Tonalité d'avertissement	RP/HOLD   Réponse à appel parlophonique	 Conversation téléphonique
---	---	---	--

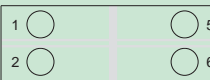
Transfert d'un appel téléphonique sur un autre appareil dérivé

 Conversation téléphonique	 Touche intercommunication 1...8	 Mélodie en ligne	 L'appareil dérivé appelé sonne
--	--	---	---

Commandes spéciaux Simplebus (valable pour standard 2906 équipée avec carte 2912)

 Décrocher le récepteur	 Tonalité continue	  X X = chiffre de 1 à 8	 Tonalité confirmation
---	--	---	--

PROGRAMMATION

NUMEROS BREFS

Enregistrement des numéros brefs de 01 à 04

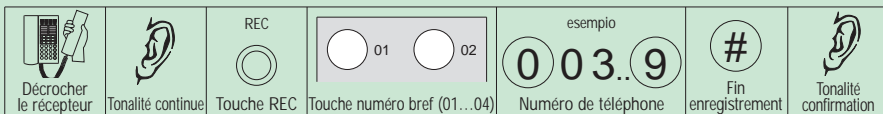

Enregistrement des numéros brefs de 05 à 40

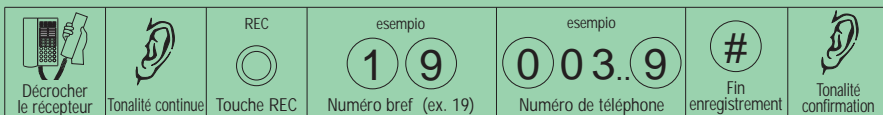

MESSAGE DE COURTOISIE

Habilitation message de courtoisie

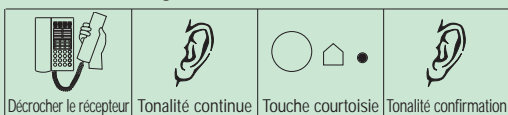

Invalidation message de courtoisie

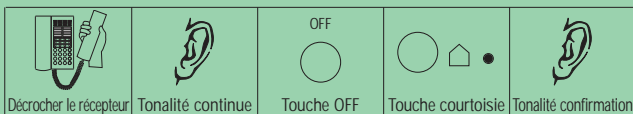

Enregistrement message de courtoisie

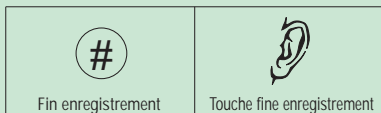
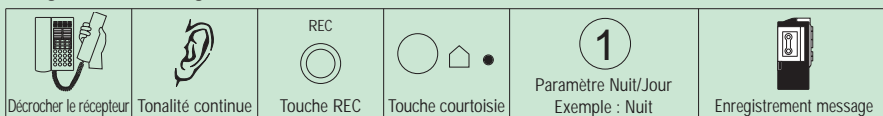

SUIVEZ-MOI PARLOPHONIQUE (FOLLOW-ME)

Habilitation Suivez-moi parlophonique

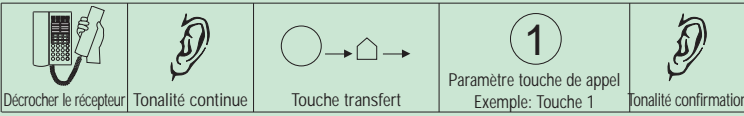

Invalidation Suivez-moi parlophonique

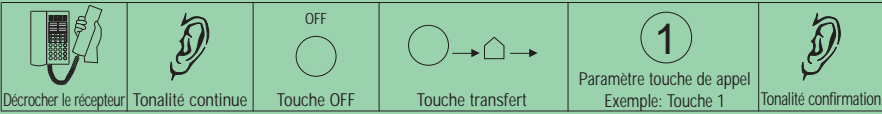

SUIVEZ-MOI LIGNE SU LIGNE (standard avec 2 lignes de téléphone)

Habilitation Suivez-moi Ligne sur Ligne

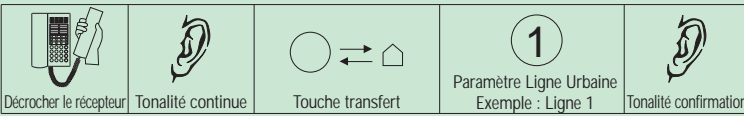

Invalidation Suivez-moi Ligne sur Ligne

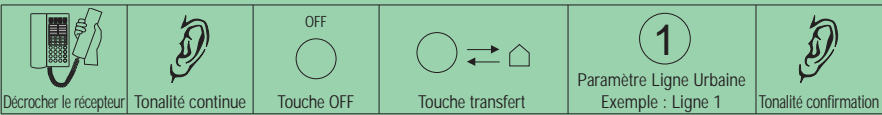

SELECTION PASSANTE (DISA)

Validation DISA

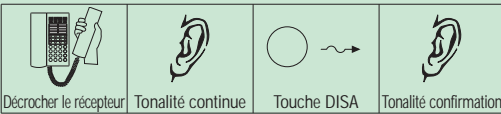

Invalidation DISA

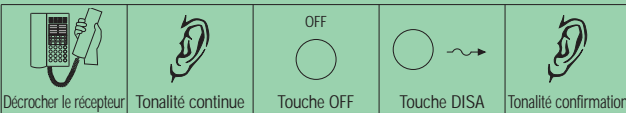

Recording DISA message

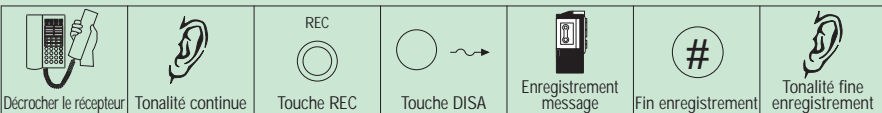

COMBINE COMTEL.TYPOLOGIE D'USAGE N° 3: APPAREIL DERIVE USAGER

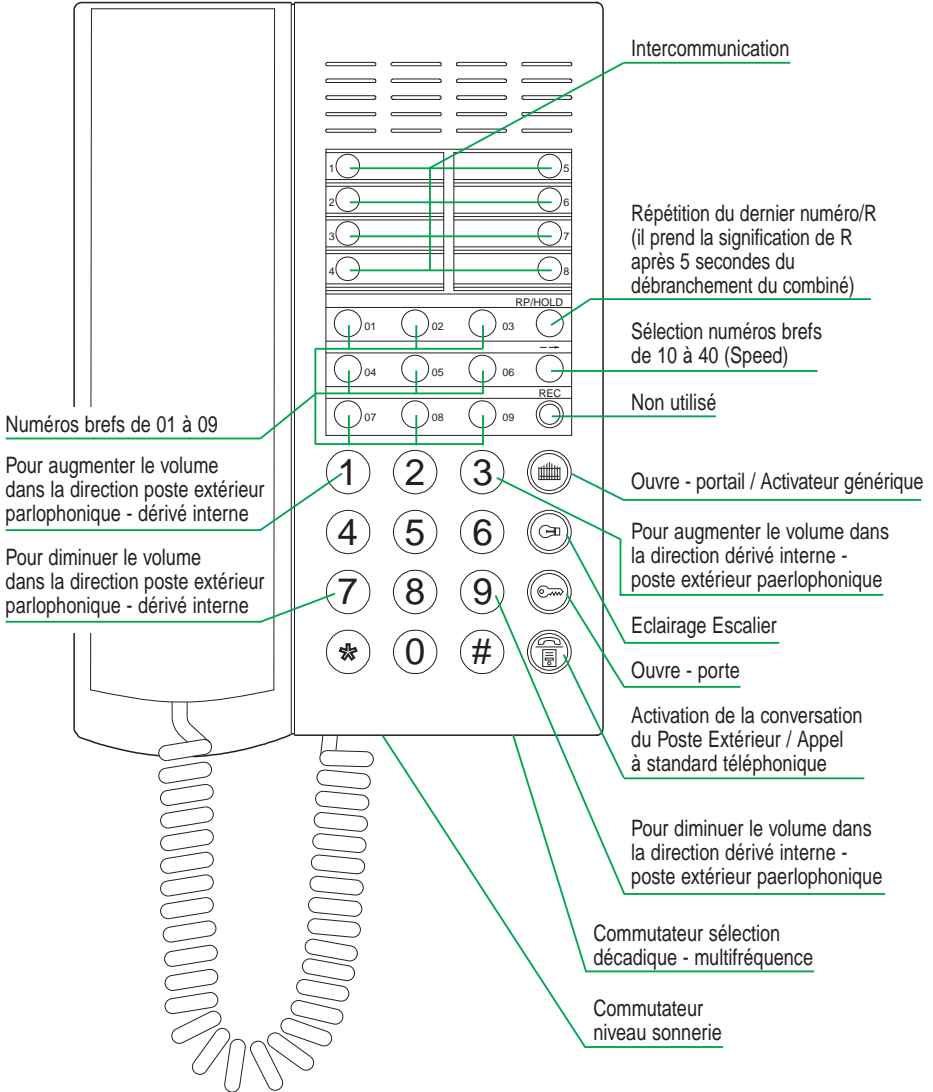

CHOIX DE LA TYPOLOGIE

Le Téléphone COMTEL Art. 1926 réalise les 3 fonctions décrites ci-dessous:

- 1** Appareil dérivé opérateur, associé à la standard téléphonique Art. 1906.
- 2** Appareil dérivé opérateur, associé à la standard téléphonique Art. 2906.
- 3** Appareil dérivé usager, associé à la standard téléphonique Art. 2906.

Pour choisir la typologie désirée, intervenir sur le commutateur situé sur le dos du téléphone (voir figure), mettre en place l'étiquette légende appropriée et configurer la centrale téléphonique comme décrit dans le manuel (Réf manuel MT/CT/01 annexe A paramètre 20).

Le présent manuel décrit uniquement les fonctions de la typologie 3. Pour les autres fonctions, consulter le manuel fourni avec la centrale téléphonique.

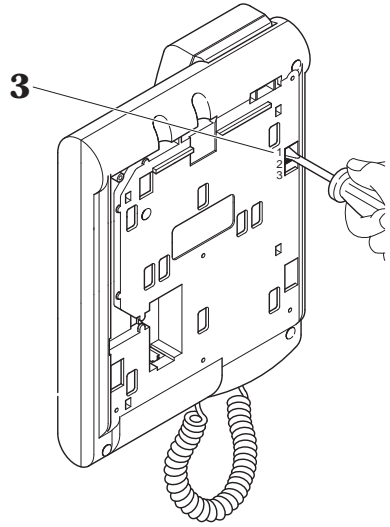

FONCTIONS

Pour effectuer un appel téléphonique

				exemple Numéro de téléphone
Décrocher le récepteur	Tonalité continue	Touche 0	Tonalité de ligne	







Intercommunication

				Bla bla
Décrocher le récepteur	Tonalité continue	Touche intercommunication 1...8	L'appareil dérivé appelé sonne	Conversation

Appel numéros brefs 01...09

				Bla bla
Décrocher le récepteur	Tonalité continue	Touche numéro bref (01...09)	Le Téléphone à distance sonne	Conversation

Appel numéros brefs 10...40

			exemple  		
Décrocher le récepteur	Tonalité continue	Touche SPEED	Numéro bref (ex. 19)	Le Téléphone à distance sonne	Conversation

Répétition dernier numéro

		RP/HOLD 
Décrocher le récepteur	Tonalité continue	Répétition du dernier numéro

Eclairage Escalier (valable pour standard 2906 équipée avec carte 2909)

			
Décrocher le récepteur	Tonalité continue	Touche éclairage escalier	Tonalité confirmation

Ouvre-porte

			
Décrocher le récepteur	Tonalité continue	Touche ouvre-porte	Tonalité confirmation

Ouvre-portail (valable pour standard 2906 équipée avec carte 2909)

			
Décrocher le récepteur	Tonalité continue	Touche ouvre-portail	Tonalité confirmation

Activateur générique (valable pour standard 2906 équipée avec carte 2912)

			
Décrocher le récepteur	Tonalité continue	Gate opening button	Confirmation tone

Activation de la conversation du Poste Extérieur (valable pour standard 2906 équipée avec carte 2909)

			
Décrocher le récepteur	Tonalité continue		Conversation





Appel à standard Simplebus (valable pour standard 2906 équipée avec carte 2909)

			
Décrocher le récepteur	Tonalité continue		Tonalité confirmation

Eclairage Escalier sur appel du poste extérieur (valable pour standard 2906 équipée avec carte 2909)

 Appel du poste extérieur	 Décrocher le récepteur	 Conversation	 Touche éclairage escalier	 Tonalité confirmation
---	---	---	--	--

Ouvre-porte sur appel du poste extérieur

 Appel du poste extérieur	 Décrocher le récepteur	 Conversation	 Touche ouvre-porte	 Tonalité confirmation
---	---	---	---	--







Ouvre portail / Activateur sur appel parlophonique

 Appel du poste extérieur	 Décrocher le récepteur	 Conversation	 Touche ouvre-portail	 Tonalité confirmation
---	---	---	---	--





Mise en attente d'une conversation téléphonique

 Conversation téléphonique	RP/HOLD  Touche Mise en attente	 Tonalité continue	 Mélodie en ligne
--	--	--	---



Appel du poste extérieur durant une conversation téléphonique

 Conversation téléphonique	 Tonalité d'avertissement	RP/HOLD   Réponse à appel parlophonique	 Conversation avec le poste extérieur	 Mélodie en ligne
--	---	---	---	---

Appel téléphonique durant une conversation avec le poste extérieur

 Conversation avec le poste extérieur	 Tonalité d'avertissement	RP/HOLD   Réponse à appel parlophonique	 Conversation téléphonique
---	---	---	--

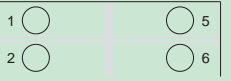
Transfert d'un appel téléphonique sur un autre appareil dérivé

 Conversation téléphonique	 Touche intercommunication 1...8	 Mélodie en ligne	 L'appareil dérivé appelé sonne
--	--	---	---

Commandes spéciaux Simplebus (valable pour standard 2906 équipée avec carte 2912)

 Décrocher le récepteur	 Tonalité continue	 X = chiffre de 1 à 8	 Tonalité confirmation
---	--	---	--

COMTEL-TELEFOON. GEBRUIKSTYPE NR 2: OPERATORTOESTEL

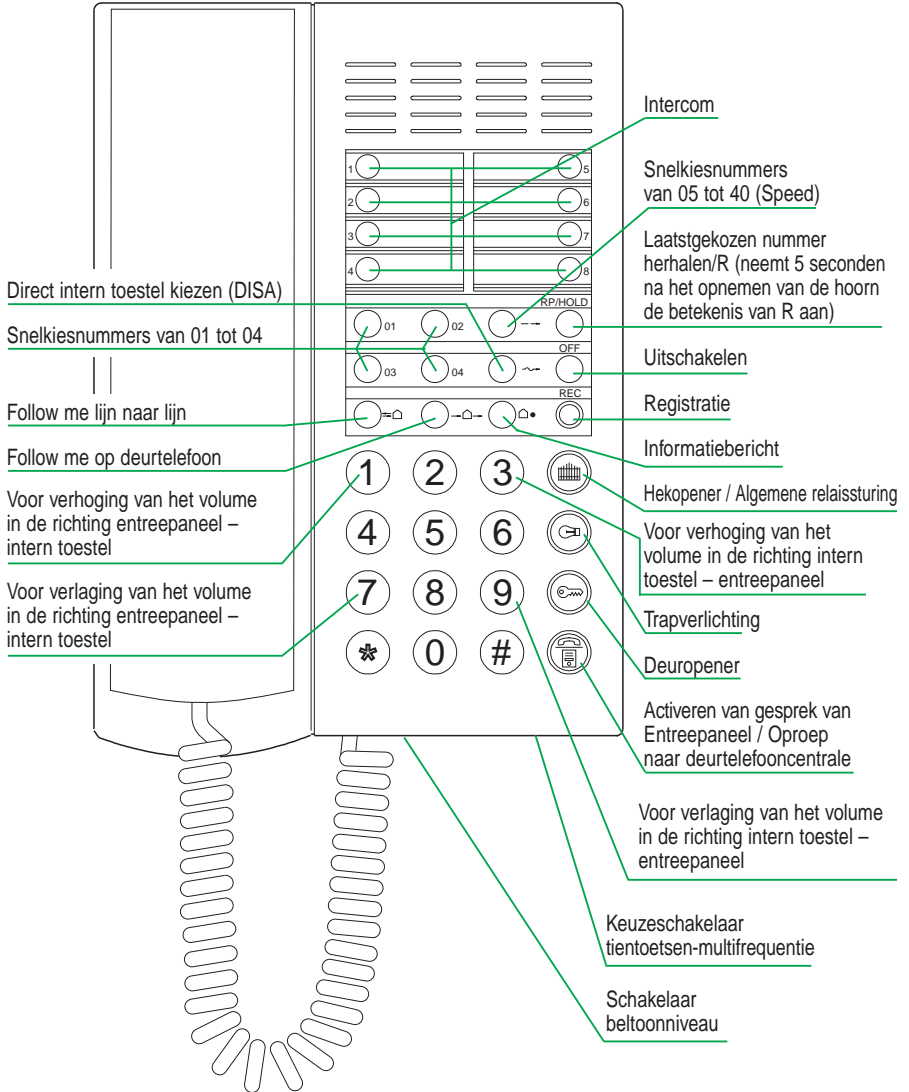

KEUZE VAN HET GEBRUIKSTYPE

De COMTEL-telefoon art. 1926 is geschikt voor 3 verschillende functies die hieronder worden beschreven:

- 1** Operatortoestel, aangesloten op de telefooncentrale art. 1906.
- 2** Operatortoestel, aangesloten op de telefooncentrale art. 2906.
- 3** Gebruikerstoestel, aangesloten op de telefooncentrale art. 2906.

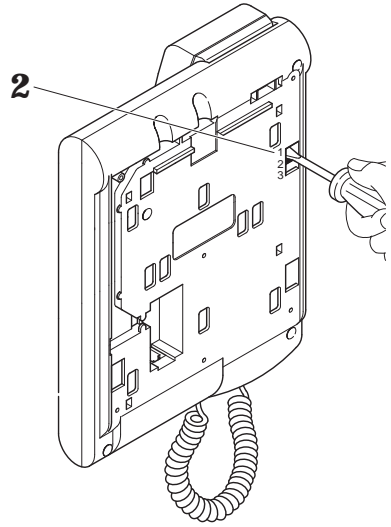

U kunt het gebruikstype kiezen door de schakelaar op de achterkant (zie afbeelding) in de gewenste stand te zetten, het juiste legenda-etiket te plaatsen en de telefooncentrale te configureren volgens de handleiding (zie handleiding MT CT 01 appendix A parameter 20).

In dit deel van de handleiding staan alleen de functies van het type **2**. Zie voor meer functies de handleiding die bij de telefooncentrale is geleverd.

NEDERLANDS

FUNCTIES

Een telefoontoespraak maken

 De hoorn opnemen	 Continue toon	 Toets 0	 Kiestoon	voorbeeld Telefoonnummer
----------------------	-------------------	-------------	--------------	---------------------------------





Intercom

 De hoorn opnemen	 Continue toon	 Intercomtoets 1...8	 Het opgeroepen interne toestel gaat over	 Gesprek
----------------------	-------------------	-------------------------	--	-------------

Snelkiesnummers oproepen

 De hoorn opnemen	 Continue toon	 Toets snelkiesnummer (01...04)	 Het buitentoestel gaat over	 Gesprek
----------------------	-------------------	------------------------------------	---------------------------------	-------------





Snelkiesnummers 05...40 oproepen

 De hoorn opnemen	 Continue toon	 Toets SPEED	voorbeeld  Snelkiesnummer (es.19)	 Het buitentoestel gaat over	 Gesprek
--	--	--	--	--	--

Laatstgekozen nummer herhalen

 De hoorn opnemen	 Continue toon	RP/HOLD  Laatstgekozen nummer herhalen
--	--	---

Trapverlichting (geldig voor centrale 2906 voorzien van kaart 2909)

 De hoorn opnemen	 Continue toon	 Toets trapverlichting	 Bevestigingston
--	--	--	--

Deuropener

 De hoorn opnemen	 Continue toon	 Toets deuropener	 Bevestigingston
--	--	---	--

Hekopener (geldig voor centrale 2906 voorzien van kaart 2909)

 De hoorn opnemen	 Continue toon	 Toets hekopener	 Bevestigingston
--	--	--	--

Algemene relaissturing (geldig voor centrale 2906 voorzien van kaart 2912)

 De hoorn opnemen	 Continue toon	 Toets hekopener	 Bevestigingston
--	--	--	--

Activeren van het gesprek van Entreepaneel (geldig voor centrale 2906 voorzien van kaart 2909)

 De hoorn opnemen	 Continue toon	 Toets deuropener	 Deurtelefoongesprek
--	--	---	--

Oproep naar deurtelefooncentrale Simplebus (geldig voor centrale 2906 voorzien van kaart 2912)

 De hoorn opnemen	 Continue toon	 Toets deuropener	 Bevestigingston
--	--	---	--

Trapverlichting op deurtelefoonoproep (geldig voor centrale 2906 voorzien van kaart 2909)

 Deurtelefoonoproep	 Hoorn opnemen	 Deurtelefoongesprek	 Toets trapverlichting	 Bevestigingstoon
---	--	--	--	---

Deuropener op deurtelefoonoproep

 Deurtelefoonoproep	 Hoorn opnemen	 Deurtelefoongesprek	 Toets deuropener	 Bevestigingstoon
---	--	--	---	---







Hekopener / Relaissturing op deurtelefoonoproep

 Deurtelefoonoproep	 Hoorn opnemen	 Deurtelefoongesprek	 Toets hekopener	 Bevestigingstoon
---	--	--	--	---

In de wacht zetten van een telefoongesprek

 Telefoongesprek	RP/HOLD 	 Continue toon	 Muziek op de lijn
--	--	--	--



Deurtelefoonoproep tijdens een telefoongesprek

 Telefoongesprek	 Aanklopton	RP/HOLD  	 Deurtelefoongesprek	 Muziek op de lijn
--	---	--	--	--

Telefoongesprek tijdens deurtelefoongesprek

 Deurtelefoongesprek	 Aanklopton	RP/HOLD  	 Telefoongesprek
--	---	--	--

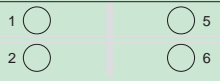
Dorschakelen van een telefoongesprek naar een ander intern toestel

 Telefoongesprek	 Intercomtoets 1...8	 Muziek op de lijn	 Het opgeroepen interne toestel gaat over
--	--	--	---







Speciale opdrachten Simplebus (geldig voor centrale 2906 voorzien van extra kaart 2912)

 Hoorn opnemen	 Continue toon	  X X = cijfer van 1 tot 8	 Bevestigingstoon
--	--	---	---







PROGRAMMERING

SNELKIESNUMMERS

Registratie snelkiesnummers van 01 tot 04

 Hoorn opnemen	 Continue toon	REC  Toets REC	voorbeeld  Toets snelkiesnummer (01...04)	voorbeeld  Telefoonnummer	# Einde opname	 Bevestigingston
---	--	---	--	--	-------------------	--

Registratie snelkiesnummers van 05 tot 40





 Hoorn opnemen	 Continue toon	REC  Toets REC	voorbeeld  Snelkiesnummer (bijv. 19)	voorbeeld  Telefoonnummer	# Einde opname	 Bevestigingston
---	--	---	---	--	-------------------	--

INFORMATIE-BERICHT:







Inschakelen informatiebericht

 Hoorn opnemen	 Continue toon	 Toets informatiebericht	 Bevestigingston
---	--	--	--

Uitschakelen informatiebericht

 Hoorn opnemen	 Continue toon	OFF  Toets OFF	 Toets informatiebericht	 Bevestigingston
---	--	---	--	--

Opnemen informatiebericht

 Hoorn opnemen	 Continue toon	REC  Toets REC	 Toets informatiebericht	 Parameter Nacht/Dag Voorbeeld: Nacht	 Bericht opnemen
---	--	---	--	--	--

# Einde opname	 Bevestigingston
-------------------	--

FOLLOW ME OP DEURTELEFOON

Inschakelen Follow me op deurtelefoon

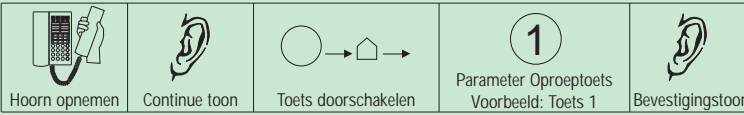

Uitschakelen Follow me op deurtelefoon

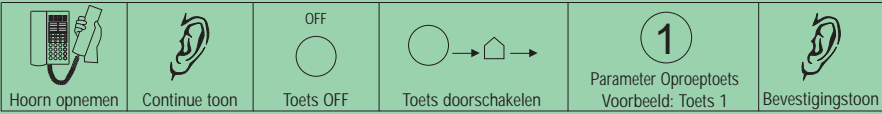

FOLLOW ME-DOORSCHAKELING VAN LIJN NAAR LIJN (met 2 telefoonlijnen)

Inschakelen Follow me lijn naar lijn

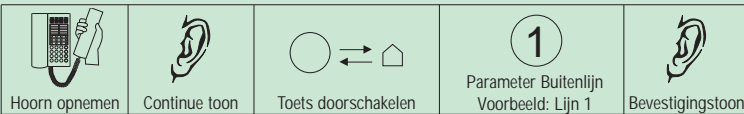

Uitschakelen Follow me lijn naar lijn

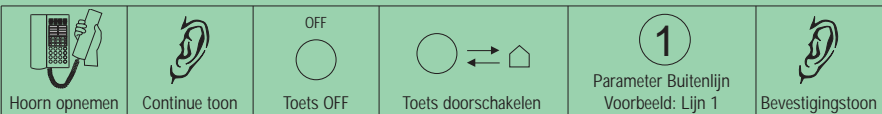

DIRECT INTERN TOESTEL KIEZEN (DISA)

Inschakelen direct intern toestel kiezen

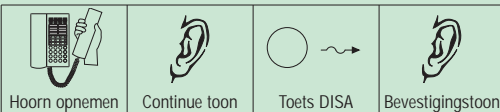

Uitschakelen direct intern toestel kiezen



Opnemen bericht voor direct intern toestel kiezen

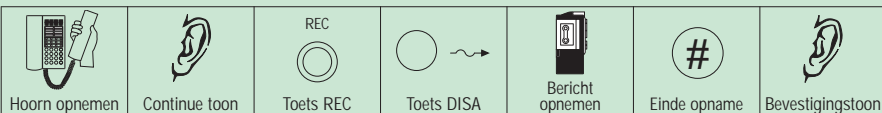

COMTEL-TELEFOON. GEBRUIKSTYPE NR 3: GEWOON GEBRUIKERSTOESTEL

NEDERLANDS

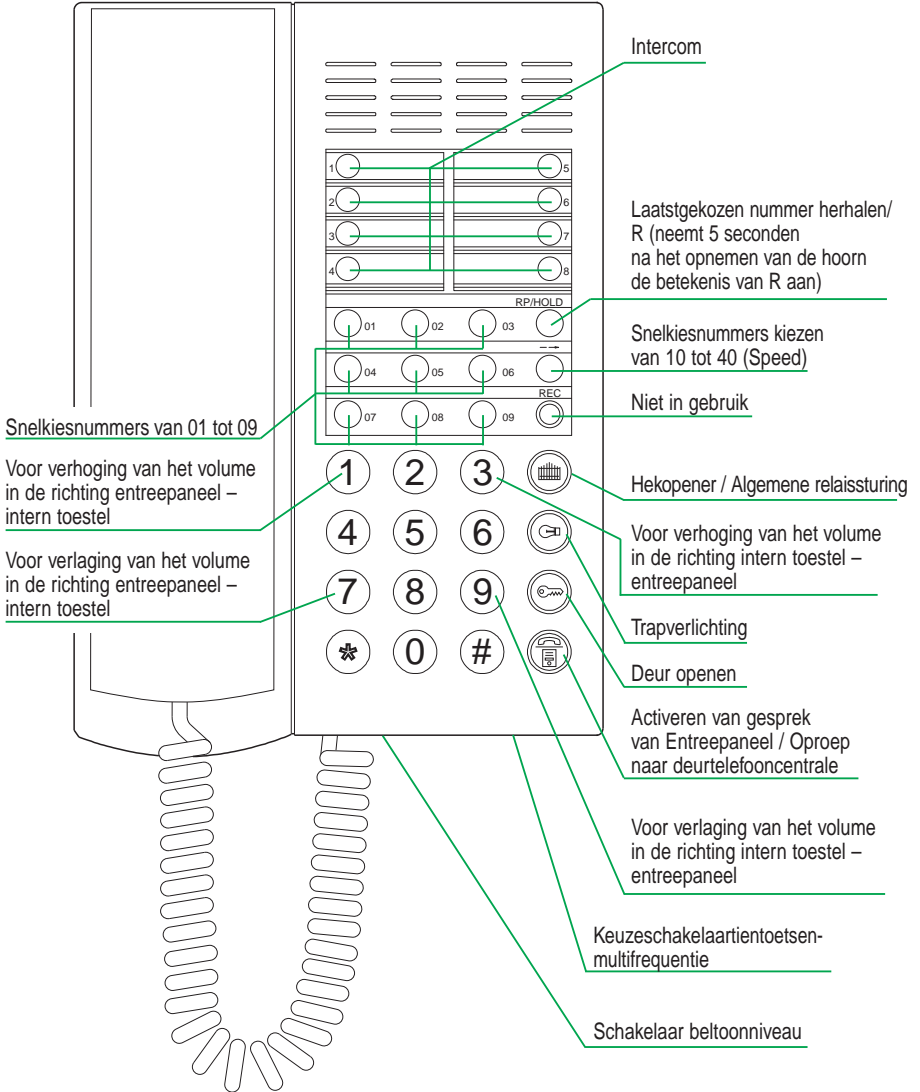

KEUZE VAN HET GEBRUIKSTYPE

De COMTEL-telefoon art. 1926 is geschikt voor 3 verschillende functies die hieronder worden beschreven:

- 1** Operatortoestel, aangesloten op de telefooncentrale art. 1906.
- 2** Operatortoestel, aangesloten op de telefooncentrale art. 2906.
- 3** Gebruikerstoestel, aangesloten op de telefooncentrale art. 2906.

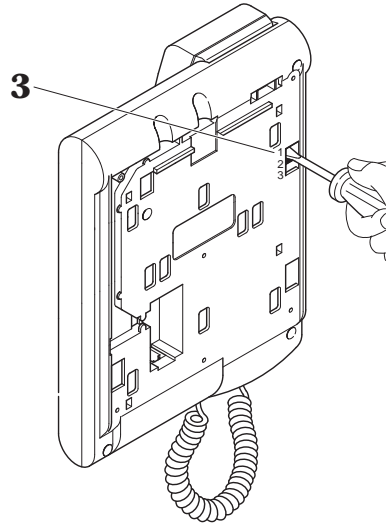

U kunt het gebruikstype kiezen door de schakelaar op de achterkant (zie afbeelding) in de gewenste stand te zetten, het juiste legenda-etiket te plaatsen en de telefooncentrale te configureren volgens de handleiding (zie handleiding MT CT 01 appendix A parameter 20).

In dit deel van de handleiding staan alleen de functies van het type **3**. Zie voor meer functies de handleiding die bij de telefooncentrale is geleverd.

NEDERLANDS

FUNCTIES

Een telefoonoproep maken

 Hoorn opnemen	 Continue toon	 Toets 0	 Kiestoon	voorbeeld Telefoonnummer
-------------------	-------------------	-------------	--------------	---------------------------------







Intercom

 Hoorn opnemen	 Continue toon	 Intercomtoets 1...8	 Het opgeroepen interne toestel gaat over	 Gesprek
-------------------	-------------------	-------------------------	--	-------------

Snelkiesnummers 01...09 oproepen

 Hoorn opnemen	 Continue toon	 Toets snelkiesnummer (01...09)	 Het buitentoestel gaat over	 Gesprek
-------------------	-------------------	------------------------------------	---------------------------------	-------------





Snelkiesnummers 10...40 oproepen

 Hoorn opnemen	 Continue toon	 Toets SPEED	voorbeeld  Snelkiesnummer (bijv.19)	 Het buitentoestel gaat over	 Gesprek
---	--	--	--	--	--

Laatstgekozen nummer herhalen

 Hoorn opnemen	 Continue toon	RP/HOLD  Laatstgekozen nummer herhalen
---	--	---

Trapverlichting (geldig voor centrale 2906 voorzien van kaart 2909)

 Hoorn opnemen	 Continue toon	 Toets trapverlichting	 Bevestigingstoon
---	--	--	---

Deuropener

 Hoorn opnemen	 Continue toon	 Toets deuropener	 Bevestigingstoon
---	--	---	---

Hekopener (geldig voor centrale 2906 voorzien van kaart 2909)

 Hoorn opnemen	 Continue toon	 Toets hekopener	 Bevestigingstoon
---	--	--	---

Algemene relaissturing (geldig voor centrale 2906 voorzien van kaart 2912)

 Hoorn opnemen	 Continue toon	 Toets hekopener	 Bevestigingstoon
---	--	--	---

Activeren van het gesprek van Entreepaneel (geldig voor centrale 2906 voorzien van kaart 2909)

 Hoorn opnemen	 Continue toon	 Toets deuropener	 Deurtelefoongesprek
---	--	---	--

Oproep naar deurtelefooncentrale Simplebus (geldig voor centrale 2906 voorzien van kaart 2912)

 Hoorn opnemen	 Continue toon	 Toets deuropener	 Bevestigingstoon
---	--	---	---

Trapverlichting op deurtelefoonoproep (geldig voor centrale 2906 voorzien van kaart 2909)

 Deurtelefoonoproep	 Hoorn opnemen	 Deurtelefoongesprek	 Toets trapverlichting	 Bevestigingstoon
---	--	--	--	---

Deuropener op deurtelefoonoproep

 Deurtelefoonoproep	 Hoorn opnemen	 Deurtelefoongesprek	 Toets deuropener	 Bevestigingstoon
---	--	--	---	---







Hekopener / Relaissturing op deurtelefoonoproep

 Deurtelefoonoproep	 Hoorn opnemen	 Deurtelefoongesprek	 Toets hekopener	 Bevestigingstoon
---	--	--	--	---

In de wacht zetten van een telefoongesprek

 Telefoongesprek	RP/HOLD 	 Continue toon	 Muziek op de lijn
--	--	--	--



Deurtelefoonoproep tijdens een telefoongesprek

 Telefoongesprek	 Aanklopton	RP/HOLD  	 Deurtelefoongesprek	 Muziek op de lijn
--	---	--	--	--



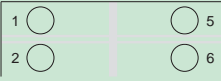

Telefoongesprek tijdens deurtelefoongesprek

 Deurtelefoongesprek	 Aanklopton	RP/HOLD  	 Telefoongesprek
--	---	--	--

Dorschakelen van een telefoongesprek naar een ander toestel

 Telefoongesprek	 Intercomtoets 1...8	 Muziek op de lijn	 Het opgeroepen interne toestel gaat over
--	--	--	---

Speciale opdrachten Simplebus (geldig voor centrale 2906 voorzien van extra kaart 2912)

 Hoorn opnemen	 Continue toon	  X X = cijfer van 1 tot 8	 Bevestigingstoon
--	--	---	---

TELÉFONO COMTEL. TIPOLOGÍA DE USO N° 2: DERIVADO UNIDAD OPERADOR

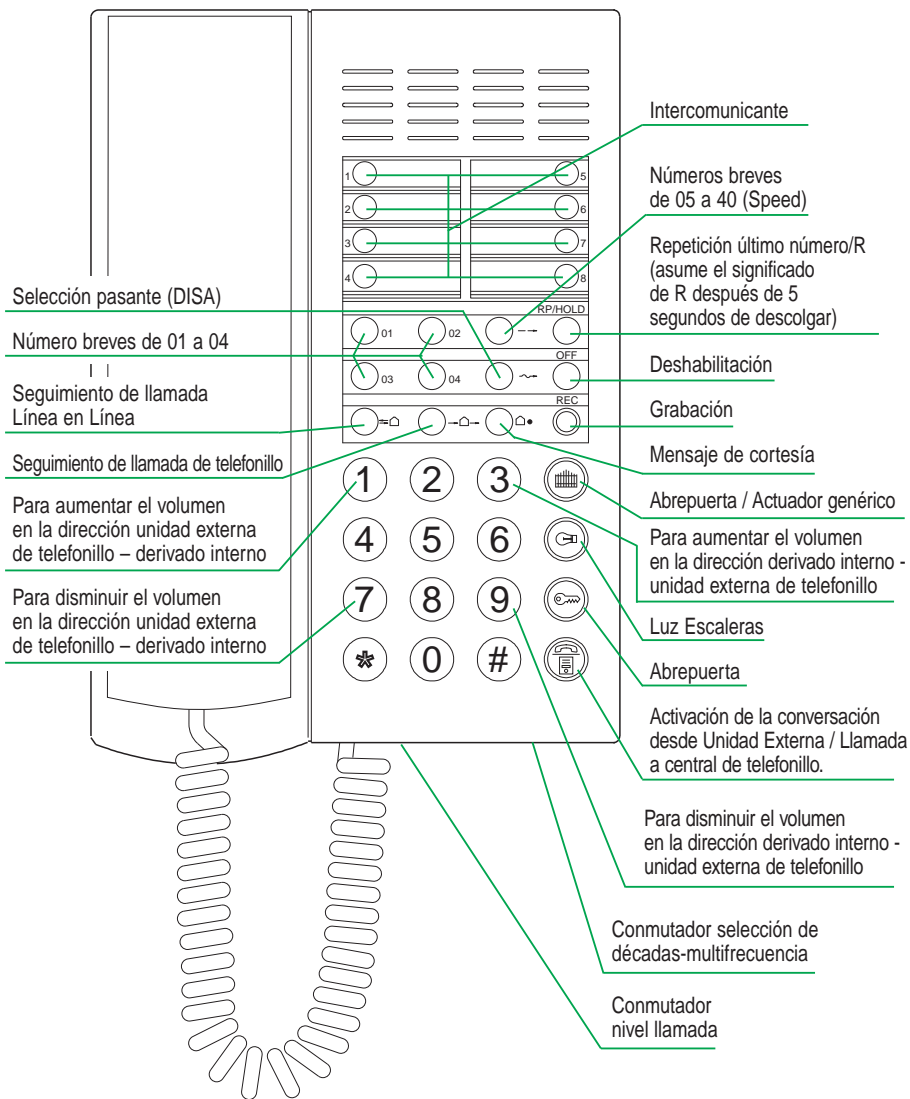

ELECCIÓN DE LA TIPOLOGÍA

El teléfono COMTEL Art. 1926 se presta a 3 funciones diferentes, a continuación aquí descritas:

- 1** Derivado unidad operador, combinado a la central telefónica Art. 1906.
- 2** Derivado unidad operador, combinado a la central telefónica Art. 2906.
- 3** Derivado usuario normal, combinado a la central telefónica Art. 2906.

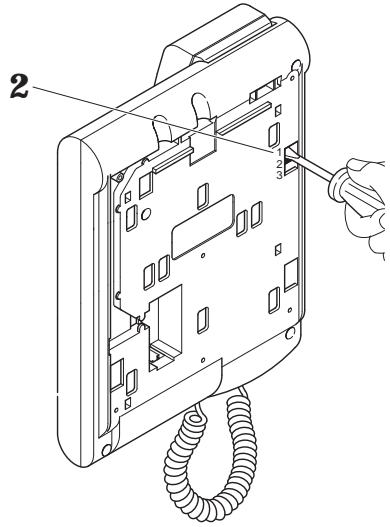

La elección de la tipología se efectúa colocando el conmutador colocado detrás (véase figura), introduciendo la etiqueta leyenda apropiada y configurando la central telefónica como en el manual (ref. manual MT CT 01 apéndice A parámetro 20).

Esta sección del manual describe solamente las funciones de la tipología **2**. Para ulteriores funciones hágase referencia al manual de la central telefónica.

FUNCIONES

Para efectuar una llamada telefónica

 Descolgar	 Tono continuo	 Tecla	 Tono de línea	ejemplo Número telefónico
---------------	-------------------	-----------	-------------------	----------------------------------







Intercomunicante

 Descolgar	 Tono continuo	 Tecla intercomunicante 1...8	 El derivado llamado suena	 Conversación
---------------	-------------------	----------------------------------	-------------------------------	------------------

Llamada números breves

 Descolgar	 Tono continuo	 Tecla número breve (01...04)	 El derivado llamado suena	 Conversación
---------------	-------------------	----------------------------------	-------------------------------	------------------

Llamada números breves 05...40

 Descolgar	 Tono continuo	 Tecla SPEED	ejemplo   Número breve (ej.19)	 El teléfono remoto suena	 Conversación
---	--	--	--	---	---

Repetición último número

 Descolgar	 Tono continuo	RP/HOLD  Repetición último número
---	--	--

Luces Escaleras (válido para central 2906 equipada con tarjeta 2909)

 Descolgar	 Tono continuo	 Tecla luces escaleras	 Tono confirmación
---	--	--	--

Abrepuerta

 Descolgar	 Tono continuo	 Tecla abrepuerta	 Tono confirmación
---	--	---	--

Abrepuerta (válido para central 2906 equipada con tarjeta 2909)

 Descolgar	 Tono continuo	 Tecla abrepuerta	 Tono confirmación
---	--	---	--

Actuador genérico (válido para central 2906 equipada con tarjeta 2912)

 Descolgar	 Tono continuo	 Tecla abrepuerta	 Tono confirmación
---	--	---	--

Activación de la conversación desde Unidad externa (válido para central 2906 equipada con tarjeta 2909)

 Descolgar	 Tono continuo	 Conversación de telefonillo	 Bla bla
---	--	--	--

Llamada a central d telefonillo Simplebus (válido para central 2906 equipada con tarjeta 2912)

 Descolgar	 Tono continuo	 Conversación de telefonillo	 Tono confirmación
---	--	--	--

Luces Escaleras en llamada de telefonillo (válido para central 2906 equipada con tarjeta 2909)

 Llamada de telefonillo	 Descolgar	 Conversación de telefonillo	 Tecla luces escaleras	 Tono confirmación
---	--	--	--	--

Abrepuerta en llamada de telefonillo

 Llamada de telefonillo	 Descolgar	 Conversación de telefonillo	 Tecla abrepuerta	 Tono confirmación
---	--	--	---	--







Abrepuerta / Actuador en llamada de telefonillo

 Llamada de telefonillo	 Descolgar	 Conversación de telefonillo	 Tecla abrepuerta	 Tono confirmación
---	--	--	---	--

Puesta en espera de una conversación telefónica

 Conversación telefónica	RP/HOLD  Puesta en espera	 Tono continuo	 Música en línea
--	--	--	--



Llamada de telefonillo durante una conversación telefónica

 Conversación telefónica	 Tono de aviso	RP/HOLD   Respuesta a llamada de telefonillo	 Conversación de telefonillo	 Música en línea
--	--	--	--	--

Llamada de telefonillo durante una conversación telefónica

 Conversación de telefonillo	 Tono de aviso	RP/HOLD   Respuesta a llamada de telefonillo	 Conversación telefónica
--	--	--	--

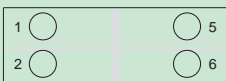
Desviación de una llamada telefónica en otro teléfono derivado

 Conversación telefónica	 Tecla intercomunicante 1...8	 Música en línea	 El derivado llamado suena
--	---	--	--

Mandos especiales Simplebus (válido para central 2906 equipada con tarjeta adicional 2912)

 Descolgar	 Tono continuo	  X X = cifra de 1 a 8	 Tono confirmación
--	--	---	--

PROGRAMACIÓN

NÚMEROS BREVES

Grabación números breves de 01 a 04

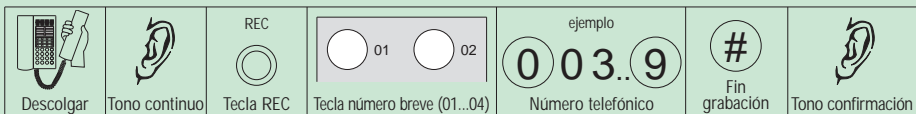

Grabación números breves de 05 a 40



MENSAJE DE CORTESÍA:

Habilitación mensaje de cortesía

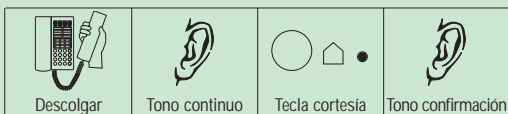

Deshabilitación mensaje de cortesía

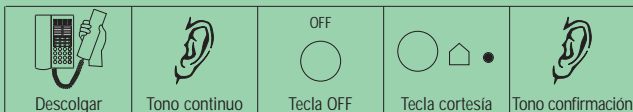

Grabación mensaje de cortesía

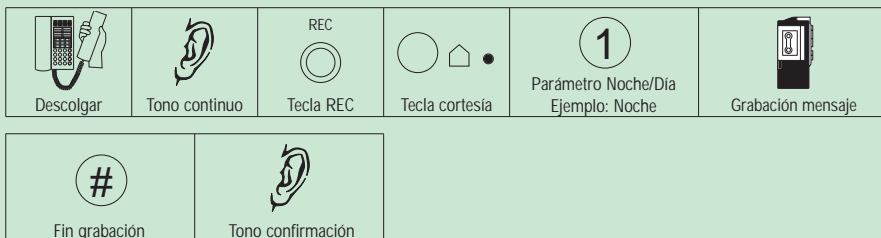

SEGUIMIENTO DE LLAMADA DE TELEFONILLO (FOLLOW ME)

Habilitación Seguimiento de llamada de telefonillo

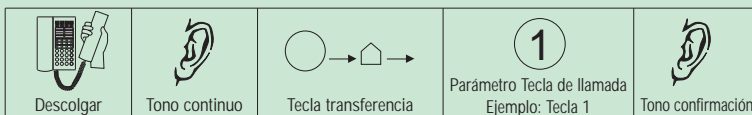

Deshabilitación Seguimiento de llamada de telefonillo

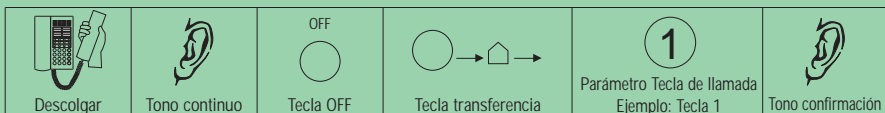

SEGUIMIENTO DE LLAMADA LÍNEA A LÍNEA (con 2 líneas telefónicas)

Habilitación Seguimiento de llamada Línea en Línea

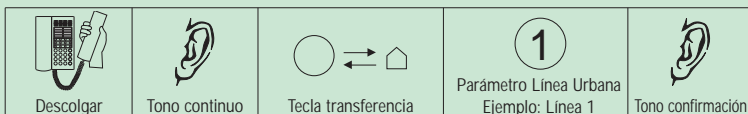

Deshabilitación Seguimiento de llamada Línea en Línea

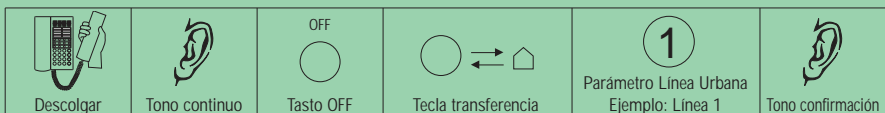

SELECCIÓN PASANTE (DISA)

Habilitación selección pasante



Deshabilitación selección pasante

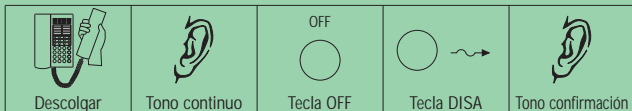

Grabación mensaje para selección pasante

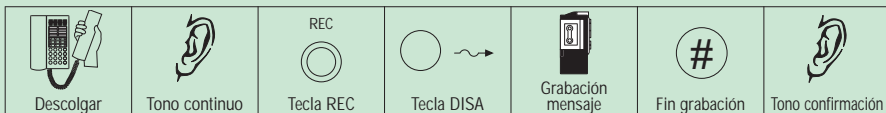

TELÉFONO COMTEL. TIPOLOGÍA DE USO Nº 3: DERIVADO USUARIO NORMAL

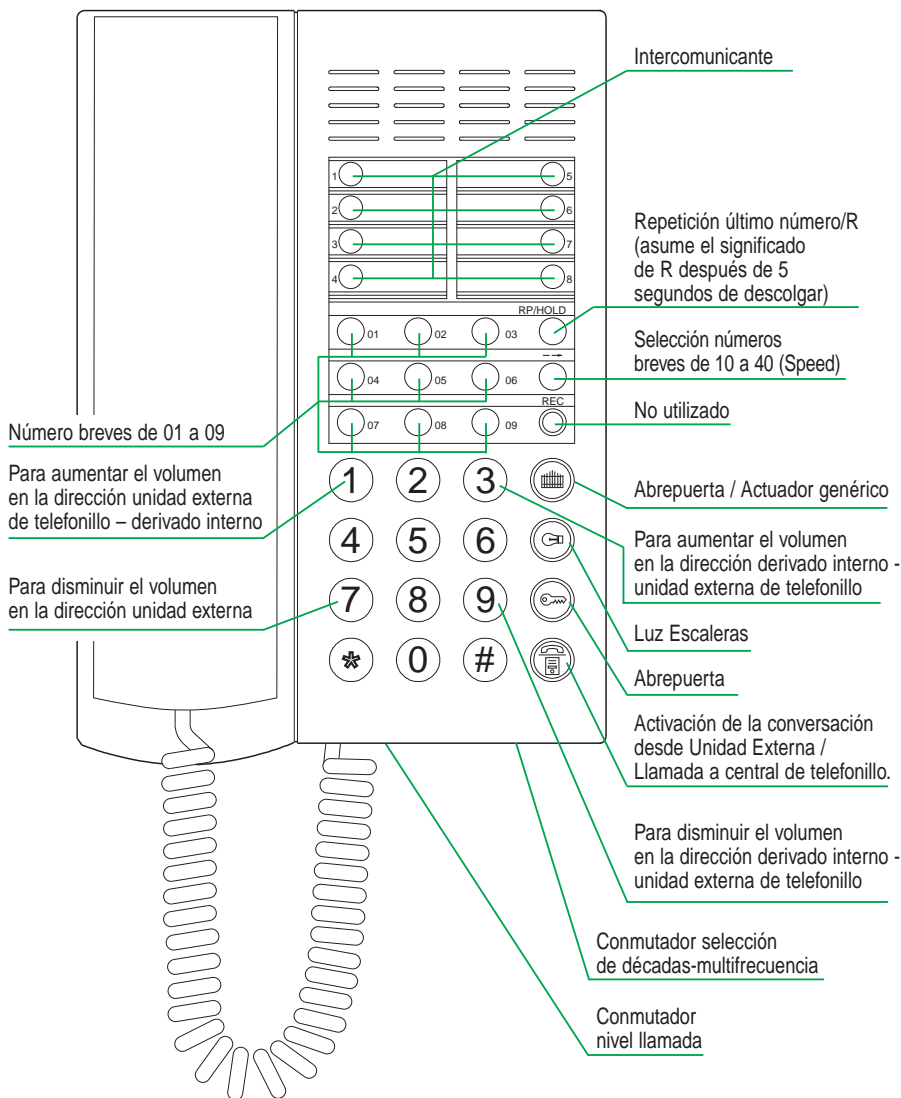

ELECCIÓN DE LA TIPOLOGÍA

El teléfono COMTEL Art. 1926 se presta a 3 funciones diferentes, a continuación aquí descritas:

- 1** Derivado unidad operador, combinado a la central telefónica Art. 1906.
- 2** Derivado unidad operador, combinado a la central telefónica Art. 2906.
- 3** Derivado usuario normal, combinado a la central telefónica Art. 2906.

La elección de la tipología se efectúa colocando el conmutador colocado detrás (véase figura), introduciendo la etiqueta leyenda apropiada y configurando la central telefónica como en el manual (ref. manual MT CT 01 apéndice A parámetro 20).

Esta sección del manual describe solamente las funciones de la tipología **3**. Para ulteriores funciones hágase referencia al manual de la central telefónica.

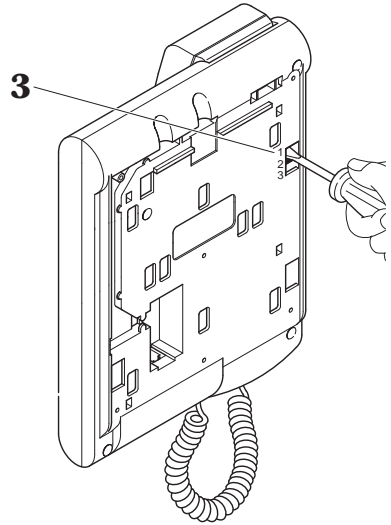

FUNCIONES

Para efectuar una llamada telefónica

				ejemplo
Descolgar	Tono continuo	Tecla 0	Tono de línea	Número telefónico







Intercomunicante

Descolgar	Tono continuo	Tecla intercomunicante 1...8	El derivado llamado suena	Conversación

Llamada números breves 01...09

Descolgar	Tono continuo	Tecla número breve (01...09)	El teléfono remoto suena	Conversación

Llamada números breves 10...40

 Descolgar	 Tono continuo	 Tecla SPEED	ejemplo   Número breve (ej.19)	 El teléfono remoto suena	 Conversación
---	--	--	--	---	---

Repetición último número

 Descolgar	 Tono continuo	RP/HOLD  Repetición último número
---	--	--





Luces Escaleras (válido para central 2906 equipada con tarjeta 2909)

 Descolgar	 Tono continuo	 Tecla luces escaleras	 Tono confirmación
---	--	--	--

Abrepuerta

 Descolgar	 Tono continuo	 Tecla abrepuerta	 Tono confirmación
---	--	---	--

Abrepuerta (válido para central 2906 equipada con tarjeta 2909)

 Descolgar	 Tono continuo	 Tecla abrepuerta	 Tono confirmación
---	--	---	--

Actuador genérico (válido para central 2906 equipada con tarjeta 2912)

 Descolgar	 Tono continuo	 Tecla abrepuerta	 Tono confirmación
---	--	---	--

Activación de la conversación desde Unidad externa (válido para central 2906 equipada con tarjeta 2909)

 Descolgar	 Tono continuo	 Conversación de telefonillo	 Bla bla
---	--	--	--

Llamada a central d telefonillo Simplebus (válido para central 2906 equipada con tarjeta 2912)

 Descolgar	 Tono continuo	 Conversación de telefonillo	 Tono confirmación
---	--	--	--

Luces Escaleras en llamada de telefonillo (válido para central 2906 equipada con tarjeta 2909)

 Llamada de telefonillo	 Descolgar	 Conversación de telefonillo	 Tecla luces escaleras	 Tono confirmación
---	--	--	--	--

Abrepuerta en llamada de telefonillo

 Llamada de telefonillo	 Descolgar	 Conversación de telefonillo	 Tecla abrepuerta	 Tono confirmación
---	--	--	---	--







Abrepuerta / Actuador e llamada de telefonillo

 Llamada de telefonillo	 Descolgar	 Conversación de telefonillo	 Tecla abrepuerta	 Tono confirmación
---	--	--	---	--

Puesta en espera de una conversación telefónica

 Conversación telefónica	RP/HOLD  Puesta en espera	 Tono continuo	 Música en línea
--	--	--	--



Llamada de telefonillo durante una conversación telefónica

 Conversación telefónica	 Tono de aviso	RP/HOLD   Respuesta a llamada de telefonillo	 Conversación de telefonillo	 Música en línea
--	--	--	--	--

Llamada de telefonillo durante una conversación telefónica

 Conversación de telefonillo	 Tono de aviso	RP/HOLD   Respuesta a llamada telefónica	 Conversación telefónica
--	--	--	--

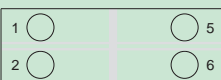
Desviación de una llamada telefónica en otro teléfono

 Conversación de telefonillo	 Tecla intercomunicante 1...8	 Música en línea	 El derivado llamado suena
--	---	--	--

Mandos especiales Simplebus (válido para central 2906 equipada con tarjeta adicional 2912)

 Descolgar	 Tono continuo	  X X = cifra de 1 a 8	 Tono confirmación
--	--	---	--



Comelit Group S.p.A. - Via Don Arrigoni 5 - 24020 Rovetta S. Lorenzo BG Italy - tel. (+39) 0346 750 011 - fax (+39) 0346 71436
www.comelit.it info@comelit.it commerciale.italia@comelit.it export.department@comelit.it



15, Rue Jean Zay
 69000 Saint Priest
 Tel 04 72 28 06 56
 Fax 04 72 28 83 29
<http://www.comelit.fr>

E-mail: Comelit.NH@wanadoo.fr



Aventurijn 220
 3314LB Dordrecht
 Tel 078 65 11 201
 Fax: 078 61 70 955
<http://www.comelit.nl>

E-mail: info@comelit.nl



Chaussée de Ninove, 900
 1703 Schepdaal (Dilbeek)
 Ninoo'ssesteenweg, 900
 1703 Schepdaal (Dilbeek)
 Tel 02 411 50 99 - Fax 02 411 50 97
<http://www.comelit.be>
 E-mail: info@comelit.be



1 Brownfields
 Wolwyn Garden City
 HERTS - AL 7 1AN
 Tel 01707 377203
 Fax 01707 377204
<http://www.comelitgroup.co.uk>
 E-mail: info@comelitgroup.co.uk



SINGAPORE REPRESENTATIVE OFFICE
 54 Genting Lane, Ruby Land
 Complex, Bk 2, #06-01
 Singapore 349562
 Tel : 65-6748 8563
 Fax: 65-6748 8584
 E-mail: comelit2004@yahoo.com.sg



Josef Estivill 67/69
 08027 Barcelona
 Tel. 932 430 376
 Fax 934 084 683
<http://www.comelit.es>
 E-mail: info@comelit.es