

**FADINI**<sup>®</sup>  
l'apricancello  
Made in Italy

I

## LIBRETTO DI ISTRUZIONI **Elpro·14 PLUS**

PROGRAMMATORE A MICROPROCESSORE  
MONOFASE-TRIFASE PER CANCELLI A  
DOPPIA ANTA SCORREVOLE

- FUNZIONE PASSO PASSO
- UOMO PRESENTE
- APERTURA PEDONALE
- SPIA DI SEGNALAZIONE DELLO STATO DELL'AUTOMAZIONE
- POSSIBILITA' DI ESCLUDERE LAMPEGGIANTE IN PAUSA
- LUCE DI CORTESIA TEMPORIZZATA
- FUNZIONE OROLOGIO

pag. 1,2,3,4

GB

## INSTRUCTIONS **Elpro·14 PLUS**

CONTROL BOARD WITH MICROPROCESSOR  
SINGLE-/THREE-PHASE  
FOR BI-PARTING SLIDING GATES

- STEP BY STEP
- DEADMAN CONTROL
- PEDESTRIAN OPENING
- GATE STATUS INDICATION
- FLASHING LAMP ON DWELL TIME MADE SWITCH ABLE
- TIMED COURTESY LIGHT
- TIME CLOCK FUNCTION

page 1,5,6,7

F

## MANUEL D'INSTRUCTION **Elpro·14 PLUS**

PROGRAMMATEUR A MICROPROCESSEUR  
MONOPHASE-TRIPHASE POUR PORTAILS  
DOUBLES COULISSANTS

- FONCTION PAS-PAS
- HOMME MORT
- OUVERTURE AUX PIETONS
- LED DE SIGNALISATION POUR L'ETAT DE L'AUTOMATISATION
- EXCLUSION VOYANT CLIGNOTANT EN PAUSE
- LUMIERE DE COURTOISIE
- HORLOGE

page 1,8,9,10

D

## ANLEITUNG **Elpro·14 PLUS**

E-STEUERUNG MIT MICROPROZESSOR,  
EIN-UND DREIPHASIG,  
FÜR DOPPELFLÜGELSCHIEBETORE

- SCHRITT FÜR SCHRITT
- TOTMANNFUNKTION
- GEHTÜRFUNKTION
- AUTOMATION STATUS ANZEIGELAMPE
- AUSSCHALTBARE BLINKLEUCHTE WÄHREND DER PAUSEZEIT
- EINSTELLBARE DECKENLEUCHTE
- SCHALTUHRFUNKTION

Seite 1,11,12,13

E

## FOLLETO DE INSTRUCCIONES **Elpro·14 PLUS**

PROGRAMADOR DE MICROPROCESADOR  
MONOFÁSICO-TRIFÁSICO PARA VERJAS DE  
DOBLE HOJA DESLIZANTE

- FUNCIÓN PASO-PASO
- HOMBRE PRESENTE
- ABERTURA PEATONAL
- INDICADOR DE SEÑALIZACIÓN ESTADO DE LA AUTOMACIÓN
- POSIBILIDAD DE DESCONECTAR DESTELLADOR EN PAUSA
- LUZ INTERIOR TEMPORIZADA
- FUNCIÓN RELOJ

pág. 1,14,15,16

NL

## GEBUIKERSHANDLEIDING **Elpro·14 PLUS**

PROGRAMMEERINRICHTING MET MICROPROCESSOR  
EENFASE-DRIEFASE VOOR SCHUIFHEKKEN MET  
TWEË VLEUGELS

- STAP-VOOR-STAP FUNCTIE
- DODEMANSFUNCTIE
- VOETGANGERSDOORGANG
- SIGNALERINGSLAMPJE VAN TOESTAND VAN AUTOMATISERING
- UITSCHAKELBAAR KNIPPERLICHT TIJDENS PAUZETIJD
- GETIMED COURTESY LIGHT
- KLOKFUNCTIE

pag. 1,17,18,19

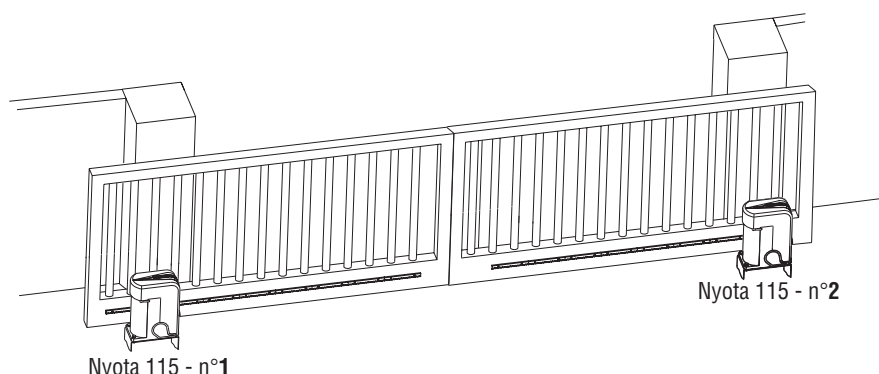

Dis. N. 4198



Via Mantova, 177/A - 37053 Cerea (Verona) Italy - Tel. +39 0442 330422 r.a.  
Fax +39 0442 331054 - e-mail: info@fadini.net - www.fadini.net



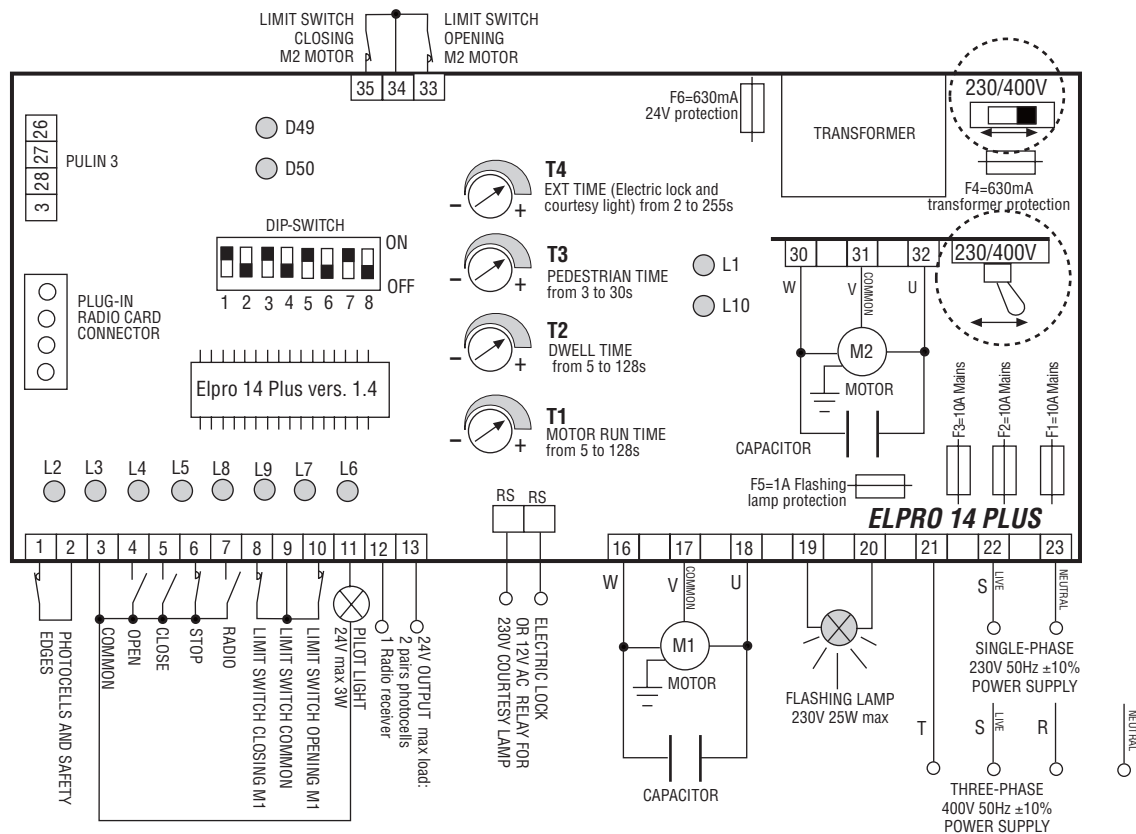

**General Description:** Elpro 14 Plus is an electronic board incorporating a microprocessor to control single- and three-phase operators for bi-parting sliding gates. Power supply is 230V/400V  $\pm 10\%$  50Hz single-/ or three-phase. It is built in compliance with BT 93/68/CE Low Voltage norms and EMC 93/68/CE norms for the electro-magnetic compatibility. Installation is recommended by a qualified technician in observance of the existing regulations. **Incorporated logic functions:** automatic or semi-automatic operating modes, pre-flashing/no pre-flashing options, reversing/non reversing options by remote control, electric lock output, pedestrian mode, hold-on-switched (deadman) control, gate status indication by leds. The manufacturer declines any responsibility for incorrect handling and applications, and reserves the right to update the instructions and the control board without notice. **Failure to observe the installation instructions may result into serious damages to persons and properties.**

**IMPORTANT:**

- The control box is to be fitted in a sheltered, dry place inside a suitable enclosure
- Fit the mains to the control box with a 0.03 A high performance, magnetic-thermal circuit breaker
- Make sure that the power supplied to the board is 230V/400V  $\pm 10\%$  50Hz
- For the power supply and the flashing lamp use 1.5 mm<sup>2</sup> wires up to 50 m distance; for the limit switches and the accessories use 1mm<sup>2</sup> wires
- Bridge terminals 1 and 2 if no photocells are required
- Bridge terminals 3 and 6 if no key- or button-switches are required
- N.W: Should other applications be required such as light switching, CCTV, etc. use only solid state relays to prevent disturbances to the microprocessor.

**Led Status Indication:**

- L1** = Power supply 230V/400V  $\pm 10\%$  50Hz a light
- L2** = Photocells. If obstructed the led goes off
- L3** = Open. It illuminates when an Open pulse is given
- L4** = Close. It illuminates when a Close pulse is given
- L5** = Stop. It goes off when a Stop pulse is given
- L6** = Radio. It illuminates when the remote control is pulsed.
- L7** = Gate Status Indication. It flashes while gate is moving
- L8** = Limit switch Closing M1 motor. Off when gate is closed
- L9** = Limit switch Opening M1 motor. Off when gate is open
- L10** = It stays a light as long as the time set on T4 Trimmer
- D49** = Limit switch Closing M2 motor. Off when gate is closed
- D50** = Limit switch Opening M2 motor. Off when gate is open

**Dip-Switch:**

- 1= ON** Photocells stop gate on opening
- 2= ON** Radio. No gate reversing on opening
- 3= ON** Automatic Closing
- 4= ON** Pre-flashing in service
- 5= ON** Radio. Step by step, stop in between
- 6= ON** Deadman Control (Dip 4=OFF and Dip 3=OFF)
- 7= ON** Flashing lamp off on dwell time, automatic mode
- 8= OFF**, blank

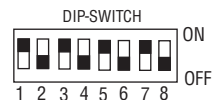
**In case the automation fails to start:**

- Check power supply to be 230V or 400V  $\pm 10\%$  50 Hz
- Check fuses
- Check photocells contacts to be normally closed
- Check all N.C. contacts
- Check that no voltage drop occurs between the board and the electric motor



**FADINI**  
the gate opener  
Made in Italy

# GB Elpro · 14 PLUS

230V-400V SINGLE- /THREE-PHASE CONTROL BOARD  
DESIGNED FOR AUTOMATIONS TO OPERATE BI-PARTING SLIDING GATES

## LOW VOLTAGE ELECTRICAL CONNECTIONS

1 2 3 4 5 6 7 8 9 10 11 12 13

### Photocells and Safety Edge:

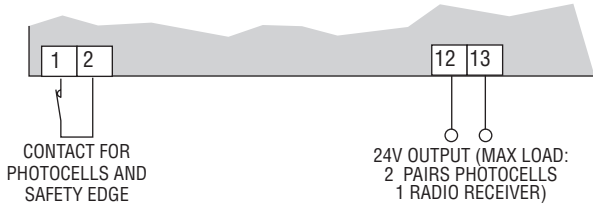

#### DIP-SWITCH 1:

- ON: Photocells stop gate on Opening and reverse it on Closing once obstacle is removed
- 1 OFF: Photocells do not stop gate on Opening and reverse it on Closing if obstructed

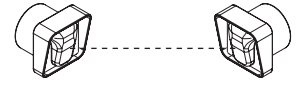

### Keyswitch:

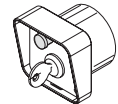
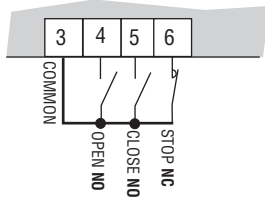

### Limit switch:



### Radio Contact:

- Open/Close (standard)
- Any new pulse reverses gate travel
- Step by step

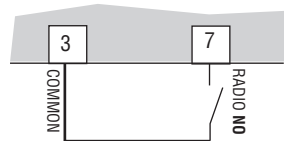

#### DIP-SWITCHES 2 & 5

(NEVER set both of them on to ON at the same time):

- 2 ON: No reversing on Opening
- 2 OFF: Reversing by any new pulse

- 5 ON: Step by step. Stop in between
- 5 OFF: Standard operating mode

### Electric Lock:

Mechanical device to hold the gate in closed gate position.  
**Trimmer T4** to the lowest  
Working Time: **2 seconds** anticipation of 100ms on gate starting.

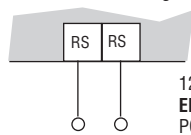

12V AC, 15VA OUTPUT  
**ELECTRIC LOCK**  
POWER SUPPLY



#### Trimmer T4

EXT TIME (Electric lock and Courtesy Light) from 2 to 255s  
**to the lowest**

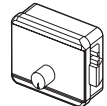

### 24V 3W Pilot Light for gate movement indication:

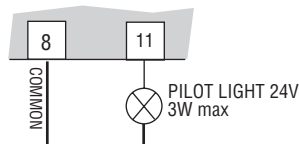

Light **On**= Gate Open. Passage allowed  
Light **Off**= Gate Closed. Passage not allowed  
Flashing **0.5s (fast)**= Gate Closing  
Flashing **1s (normal)**= Gate Opening  
With external clock: **2 short flashes** followed by a longer stop

### Push Button unit Pulin3:

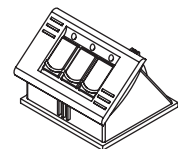
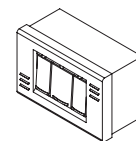
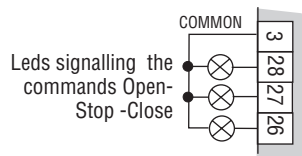

### Courtesy light:

Connect a 12VAC relay (Trimmer T4 from 2s to 255s) to operate a 230V lamp

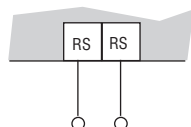

#### Trimmer T4

EXT TIME (Electric lock and Courtesy Light) from 2 to 255s



**ELECTRIC POWER CONNECTIONS**

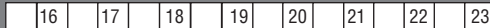

**Single- and three-phase motors:**

**Important:**  
Depending on the site voltage requirements it is absolutely necessary to set both switches accordingly

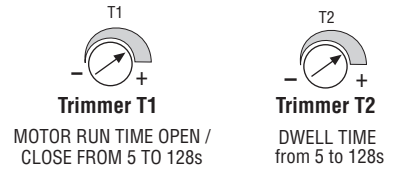
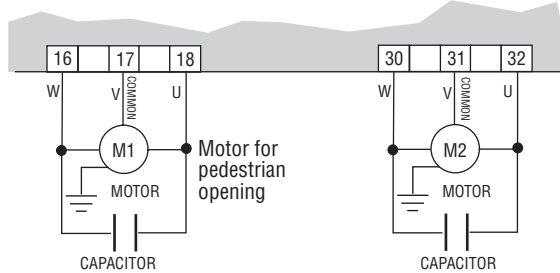

**Flashing light:**

**Pre-flashing (Dip-Switch 4=ON):** Once an Open pulse is given, after 3 seconds M1 motor starts. Once the gate is fully closed, the lamp goes on flashing for 3 more seconds.

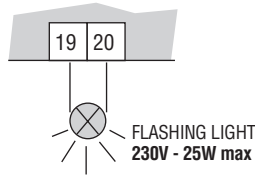

**DIP-SWITCH 4 and 7:**

- ON: Pre-flashing
  - OFF: No pre-flashing
- 4
- ON: No flashing with the lamp on Dwell time. Automatic mode
  - OFF: Flashing on Dwell time in Automatic mode option
- 7

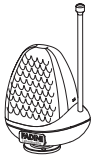

**Control board power supply:**

Fit the mains to the control board with a 0.03A high sensitivity, magnetic-thermal, differential circuit breaker. The board can be supplied 230V 50Hz ±10% Single-phase or 400V ±10% Three-phase. Both switches are to be set to the required voltage.

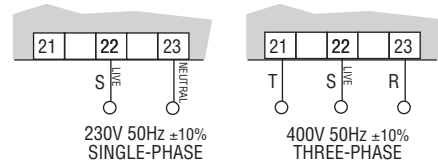
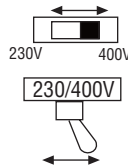

**FUNCTIONS**

**Automatic / Semi-automatic:**

**Automatic cycle:** On pulsing to Open the gate is operated to open, stops for a time equal to the dwell time as pre-set with T2 trimmer, after this time the gate is automatically operated to Close.

**Semi-automatic Cycle:** On pulsing to Open the gate is operated to Open and held in open position. A new pulse is needed for the gate to close.



**DIP-SWITCH 3**

- ON= Automatic Closing
  - OFF= No automatic closing Semi-automatic mode
- 3

**Deadman Control:**

Open and Close operations are by "hold on switched" control (no relay self-holding is involved). The automation is to be attended and the command unit is required to be held switched to achieve gate operation. Any operation is stopped on releasing the button or key.

**DIP-SWITCH 6**

- ON= Deadman Control Dip-switch 4=OFF and Dip-switch 3=OFF
  - OFF= Normal operating mode
- 6

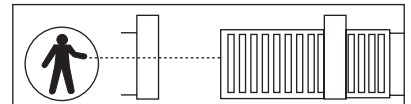

**Pedestrian Opening:**

With the gate in fully closed position, it is possible to open the gate for pedestrians by pulsing to Open with **Dip-Switch No.6=ON** terminals 3-4:

- a first Open pulse operates **Motor 1** to open
  - a second pulse operates the other gate to Open
- A pulse given to terminals 7 - 8 (Radio Contact) by the remote control always operates both gates.

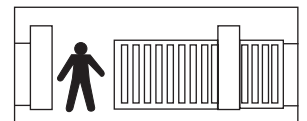
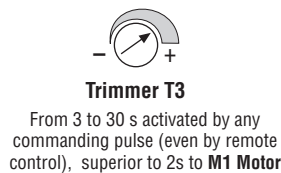

**Radio out of service on Dwell time in Automatic Mode option:**

In this Mode, any pulse given by Radio remote control during the dwell time in Automatic mode option does not allow any operation with the system. DIP-SWITCH No.2=ON, No.3=ON and No.5=ON

- ON: No gate travel reversing on Opening
  - OFF: Any new pulse reverses gate travel
- 2

- ON= Automatic Closing
  - OFF= No Automatic Closing
- 3

- ON: Step by step Stop in between
  - OFF: Standard operating mode
- 5

**Time clock:**

**How it works:** Set the clock to the required time. On the set time the gate is operated to open and held open. No other operations can be achieved (not even by remote control) until the time set on the clock has expired. On expiring of the clock time and after the dwell time of the system, the gate is automatically operated to close. Trimmer T3 is to be set on to zero, Dip-Switch No. 3=ON



**DIP-SWITCH No.3=ON Automatic Closing**

- ON= Automatic Closing
  - OFF= No automatic closing. Semi-automatic option
- 3

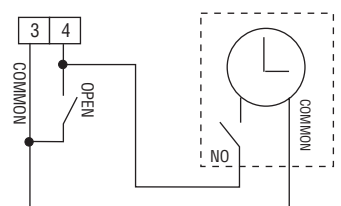

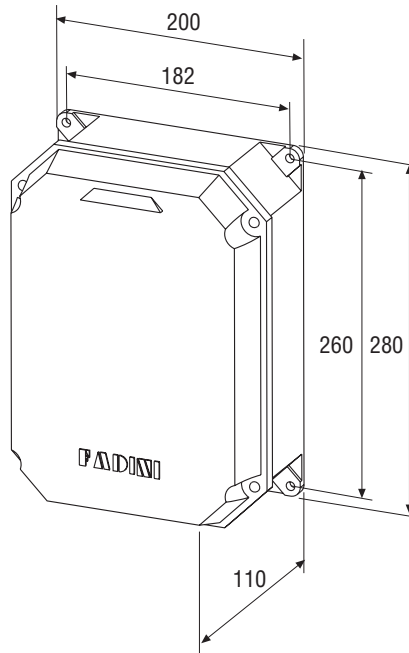

- I** - Prima dell'installazione da parte di personale tecnico qualificato, si consiglia di prendere visione del Libretto Normative di Sicurezza che la Meccanica Fadini mette a disposizione.
- GB** - Please note that installation must be carried out by qualified technicians following Meccanica Fadini's Safety Norms Manual.
- F** - L'installation doit être effectuée par un technicien qualifié suivant le manuel des Normes de Sécurité de Meccanica Fadini.
- D** - Vor der Montage durch einen Fachmann, wird es empfohlen die Anleitung zur Sicherheitsnormen, die Meccanica Fadini zur Verfügung stellt, nachzulesen.
- E** - Antes de la instalación por el personal técnico calificado, se recomienda leer detenidamente el Folleto de la Reglamentación de Seguridad que la empresa Meccanica Fadini pone a su disposición.
- NL** - Voordat de installatie door gekwalificeerd technisch personeel wordt uitgevoerd, wordt geadviseerd om het boekje met veiligheidsvoorschriften dat Meccanica Fadini ter beschikking stelt door te lezen.



**I** Direttiva **2003/108/CE**  
Smaltimento dei materiali  
elettrici ed elettronici

**VIETATO GETTARE NEI RIFIUTI**  
**MATERIALI NOCIVI PER L'AMBIENTE**

**GB** **2003/108/CE** Directive  
for waste electrical and  
electronic equipments

**DISPOSE OF PROPERLY**  
**ENVIRONMENT-NOXIOUS MATERIALS**



Via Mantova, 177/A - 37053 Cerea (Verona) Italy - Tel. +39 0442 330422 r.a. - Fax +39 0442 331054  
e-mail: [info@fadini.net](mailto:info@fadini.net) - [www.fadini.net](http://www.fadini.net)