

APROLI

280/700 **STRONG**

➤ OIL-HYDRAULIC OPERATOR DESIGNED FOR SWING GATES WITH VERY LARGE PILLARS AND HEAVY GATES

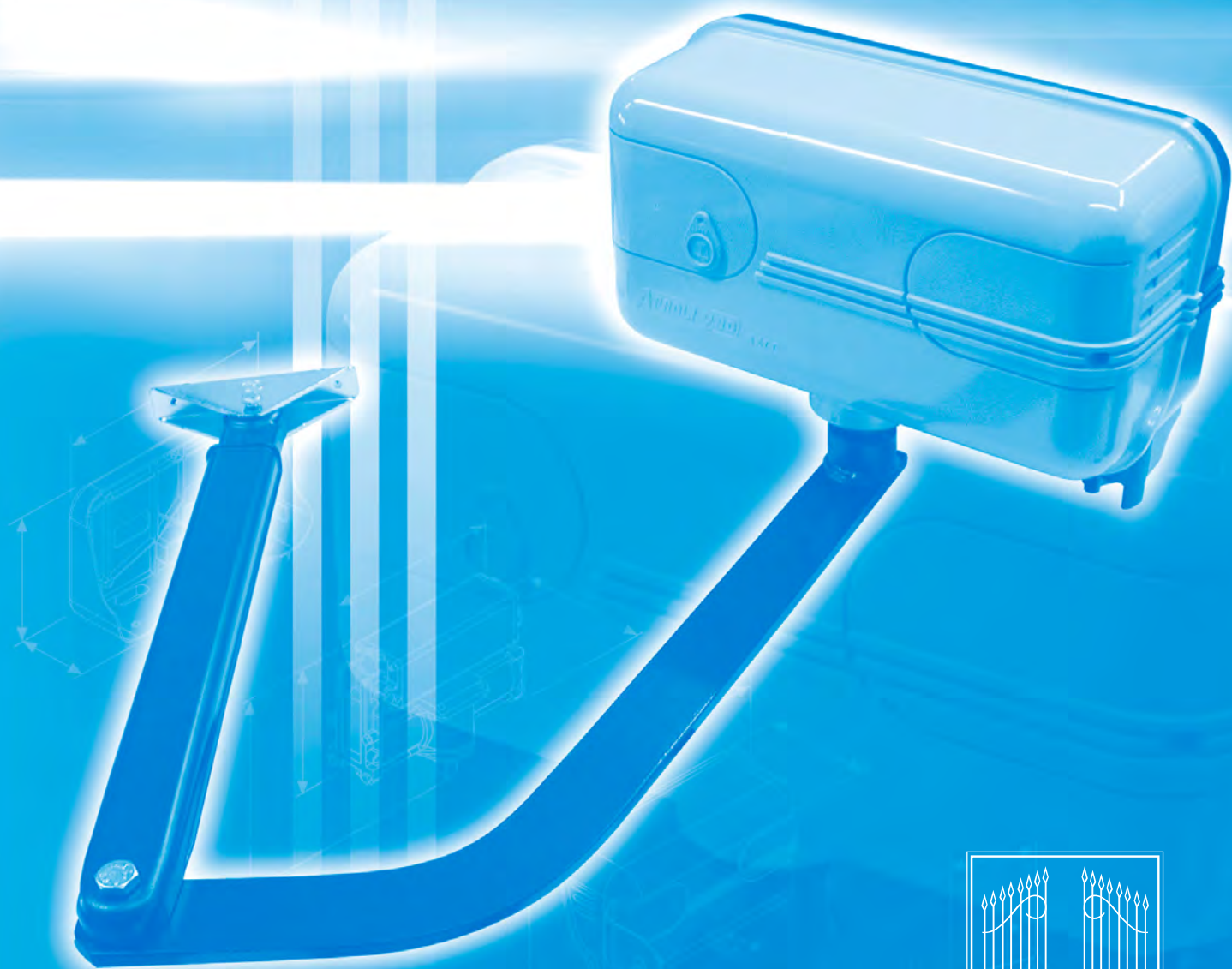

INSTALLATION MANUAL

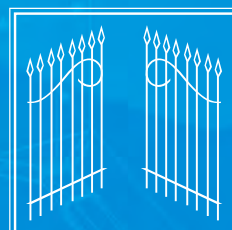

FADINI[®]
the gate opener

APROLI 280/700 STRONG

INSTRUCTIONS FOR THE INSTALLATION OF THE APROLI 280/700 STRONG SWING GATE OPERATOR

FOR CORRECT APROLI 280/700 STRONG INSTALLATION AND GOOD PERFORMANCE, PLEASE READ THE INSTRUCTIONS OUTLINED IN THIS MANUAL CAREFULLY AND KEEP TO THE DIAGRAMS.

IMPORTANT: THE ENTIRE INSTALLATION MUST BE CARRIED OUT BY QUALIFIED TECHNICAL PERSONNEL, WHO ARE ADVISED TO FOLLOW GOOD INSTALLATION PRACTICE AND KEEP TO CURRENT SAFETY STANDARDS.

GENERAL INFORMATION

- Check that the structure of the gate to be automated is suitable for the application to be installed: make sure that there are no anomalies in the metal structure, reinforce any weak points and ensure that the leaf hinges are in perfect condition.
- If necessary, reinforce the connection point between the leaf and the bended arm fixing shoe
- The gate's movement should not be obstructed in any way: excessive rises in the ground, friction in the hinges, ...
- The gate leaves must be installed and levelled on a flat surface

The Aproli 280/700 Strong is an external oil-hydraulic gate operator for swing gates, with two-directional hydraulic locking, suitable for gates with very large pillars and for heavy gates. It meets all the most demanding installation requirements thanks to the use of a bended steel arm and "telescopic" end section for leaf fixing.

We recommend using the Aproli 280/700 Strong for leaves of no more than 3.0 metres long and weighing more than 300 kg.

IMPORTANT:

- The Aproli 280/700 Strong should only be installed on gates with leaves up to 3.0 metres long

- An electric lock must always be installed for leaves of over 2.0 metres long.

It is advisable to fasten all the open and closed gate stops firmly to the ground, and to check how sturdy they are during the initial gate operation tests. (Pic.1)

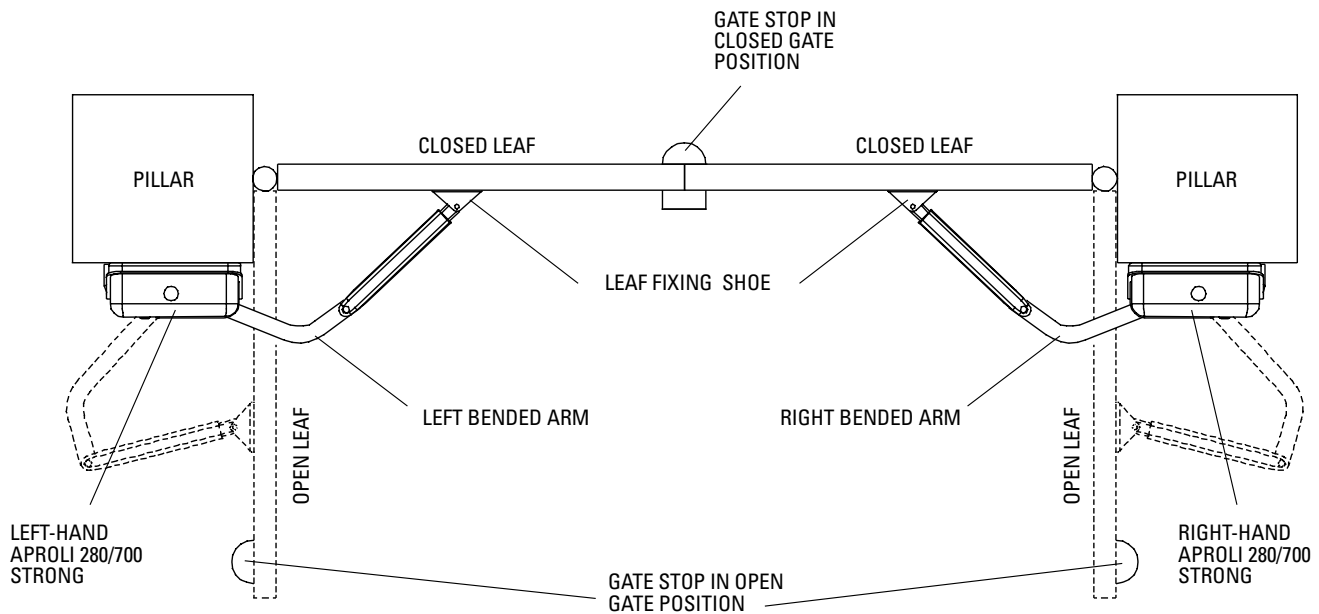

PLAN OF GATE WITH TWO APROLI 280/700 STRONG INSTALLED

➤ **PIC. 1**

Firstly slide off the whole bended arm by unscrewing the specific screw on the rotation shaft; then remove the **protection cover** by unscrewing the 2 fixing screws – **A** (Pic. 2), one of which is found inside by opening the cover with the customized key. At this point unscrew the 4 locking screws – **B** positioned beneath the automation (Pic. 2), thereby making it possible to remove the **electric motor/hydraulic jack** assembly, exposing the pillar **fixing bracket**.

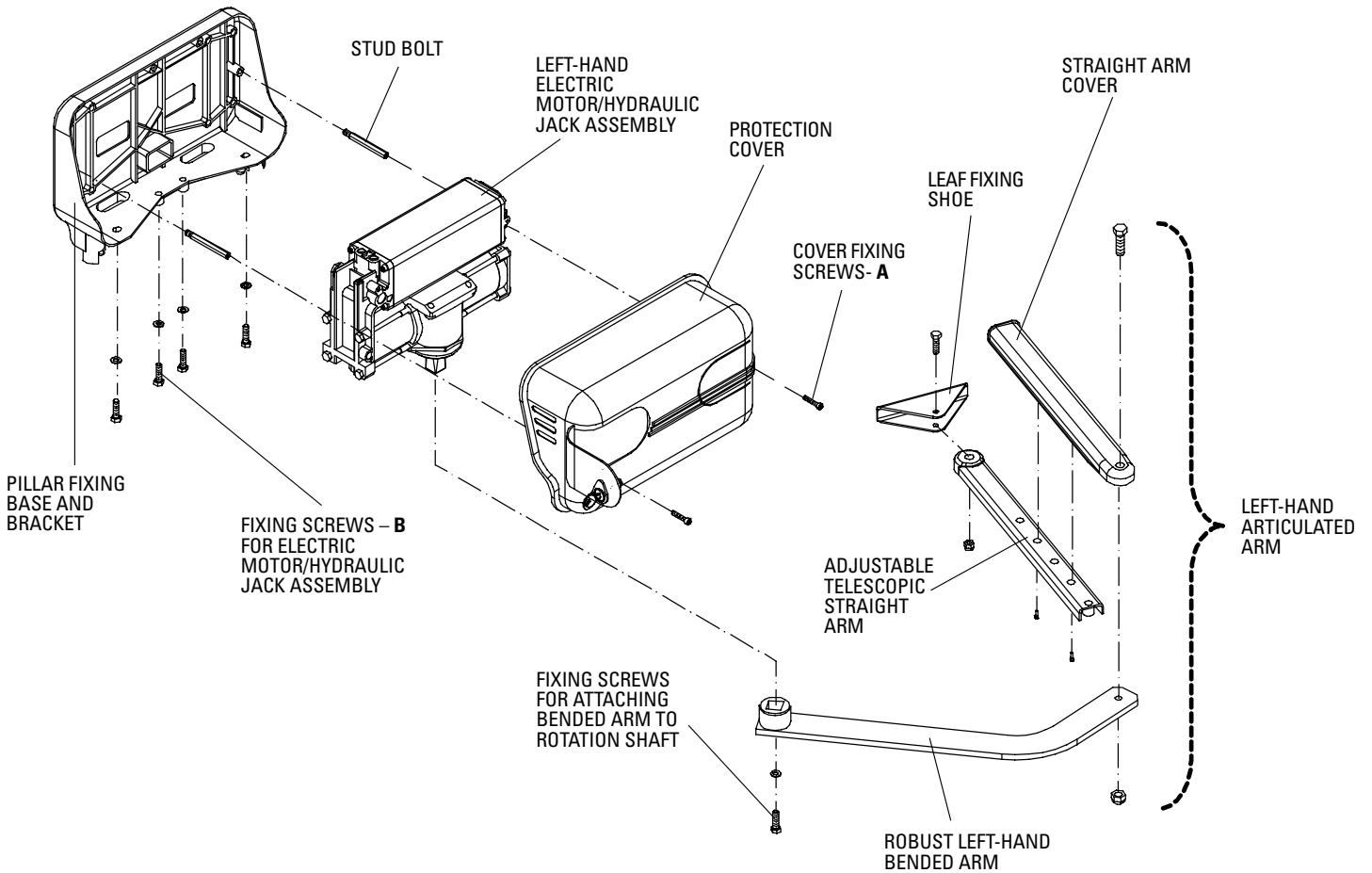

EXPLODED VIEW OF MAIN COMPONENTS OF LEFT-HAND APROLI 280/700 STRONG GATE OPERATOR

➤ **PIC. 2**

APPLICATION OF TWO APROLI 280/700 STRONG

Before proceeding with the installation and use of the Aproli 280/700 Strong, it is essential to understand the exact position of each operator in the system. The automations have the abbreviation Sx (left) and Dx (right) stamped on the hydraulic jack, which can be seen once the protection cover has been removed: in fact Right and Left are intended for an observer standing in front of the two gate leaves to be opened towards the observer himself (Pic. 3).

I.e. if the gate opens inwards the observer will be standing inside and will see the right-hand Aproli 280/700 Strong on his right; vice versa, if the gate opens outwards, the observer will be standing outside and will see the right-hand Aproli 280/700 Strong on his right.

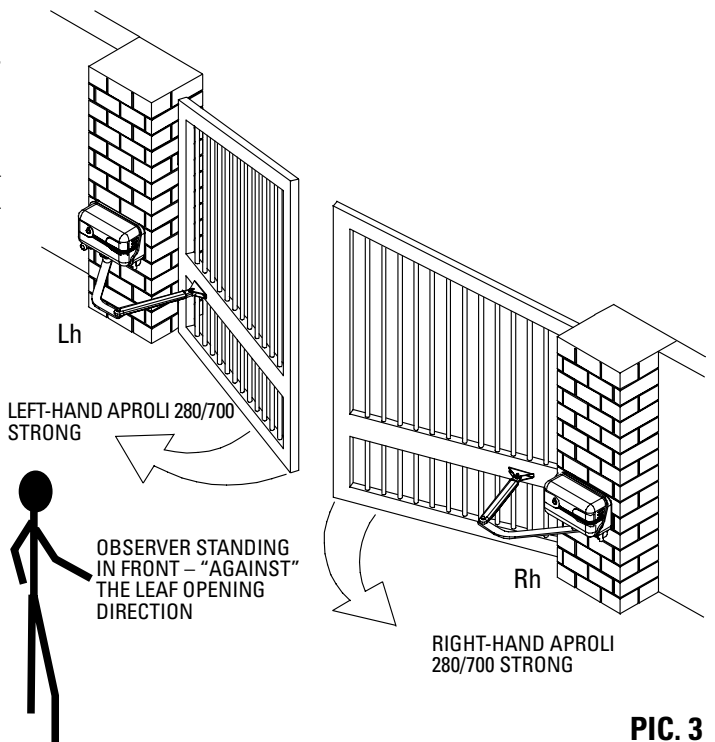

PIC. 3 ➤

SETTING APROLI 280/700 STRONG

In order to install the device, it is firstly necessary to dismantle and expose the individual components; fundamental for both optimal installation and good performance.

- Swing the lock cover flap placed on the left side of the front **protection cover** to one side (for both the RH and LH Aproli) and open the **cover** with the customized key provided (Pic. 4-A)
- Remove the **bended arm** by unscrewing the **fixing screws** positioned on the rotation shaft (for both the RH and LH Aproli) (Pic. 4-B)
- Remove the **protection cover** by unscrewing the two fixing **screws – A** on the cover. (Pic. 4-C)

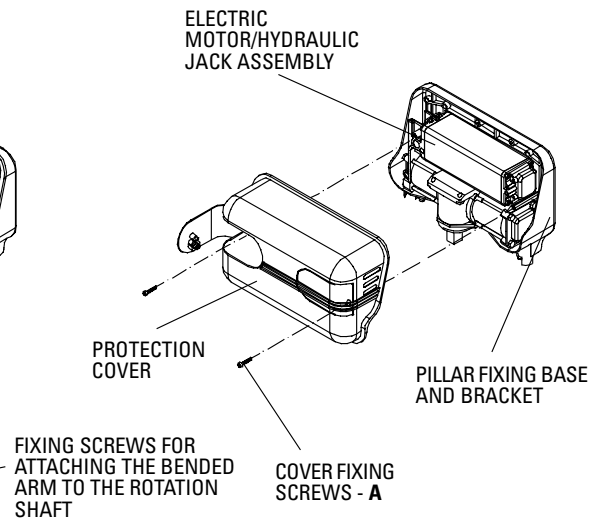
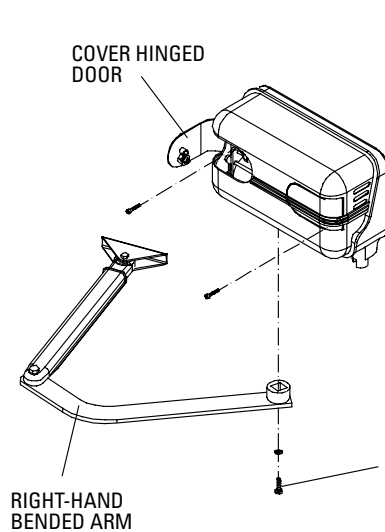
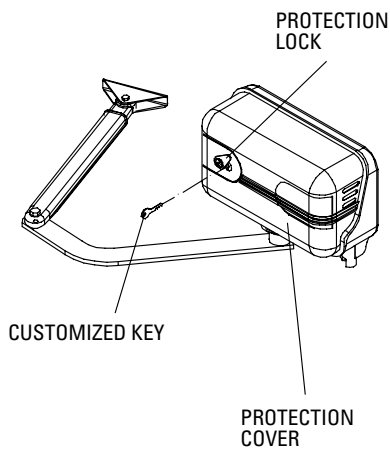

➤ **PIC. 4-A**

➤ **PIC. 4-B**

PIC. 4-C ◀

- In order to extract the **electric motor/hydraulic jack assembly** from the **fixing base**, unscrew the four **fixing screws – B** positioned under the fixing base (Pic. 5)

BENDED ARM AND TELESCOPIC CONNECTION ARM

The **straight arm** should be bolted to the **bended arm**. The straight arm offers various different assembly solutions since it has holes for connection with the **telescopic arm cover** in 3 different positions (Pic. 6), obtaining a centre distance between the **bended arm** and the **fixing shoe** equivalent to 460 mm, 520 mm or 580 mm. The **fixing shoe** is attached to a robust gate upright with screws or firmly welded in place, and is then connected to the adjustable straight arm with one screw.

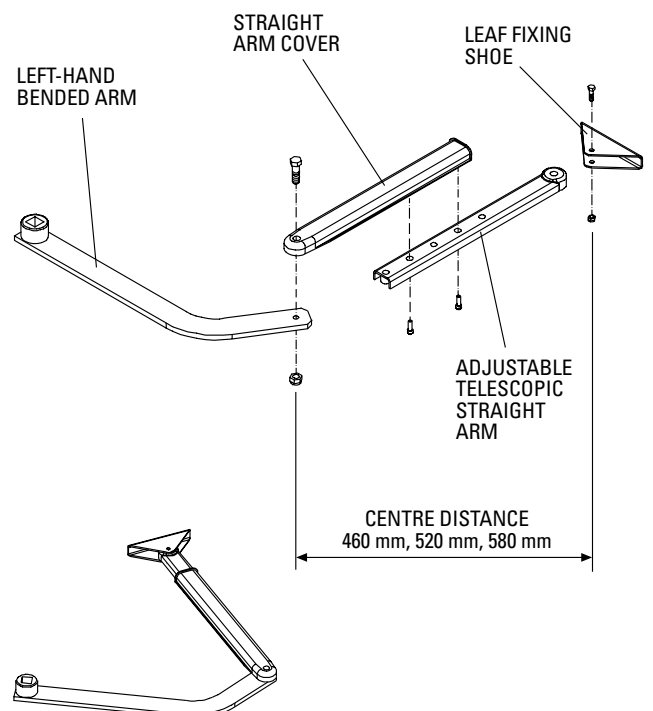
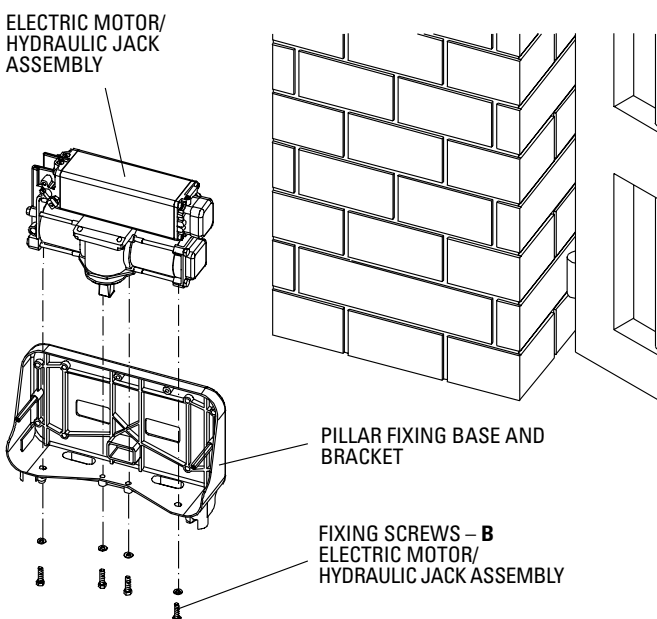

➤ **PIC. 5**

PIC. 6 ◀

FIXTURE TO THE PILLAR

Using a spirit level, fix the **fixing base** in position with suitable fixing plugs depending on the type of pillar (Pic. 7) (not provided). When deciding the height at which to fix it to the pillar, consider at what point the **articulated arm** will be connected to the gate leaf: preferably on a strong upright. The **fixing shoe** (Pic. 6) must be bolted or welded into position at a distance established after the initial manual leaf opening and closing tests, following the indicated installation heights (Pic. 8).

Once the fixing base has been installed, insert and fix the electric motor/hydraulic jack assembly into position using the **4 fixing screws – B** (Pic. 5).

The following table indicates some installation distances. These are not obligatory and are for reference purposes only (Pic. 8). The distances indicated must be used to obtain an automation that is able to close the leaf decisively.

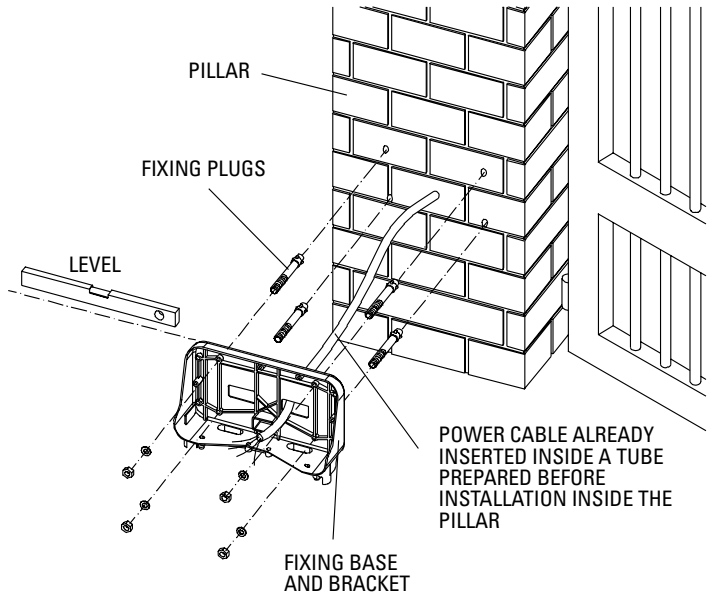

PIC. 7 ←

Pillar dimensions	A (mm)	B (mm)	C (mm)	D (mm)	G°	Gate leaf
400 x 400 (mm)	510	200	460	50	100°	2,0 m
500 x 500 (mm)	560	250	460	60	100°	3,0 m
600 x 600 (mm)	560	300	460	/	95°	1,80 m
700 x 700 (mm)	580	350	580	140	95°	3,0 m
800 x 800 (mm)	620	400	580	135	90°	4,0 m
900 x 900 (mm)	650	450	580	50	90°	5,0 m

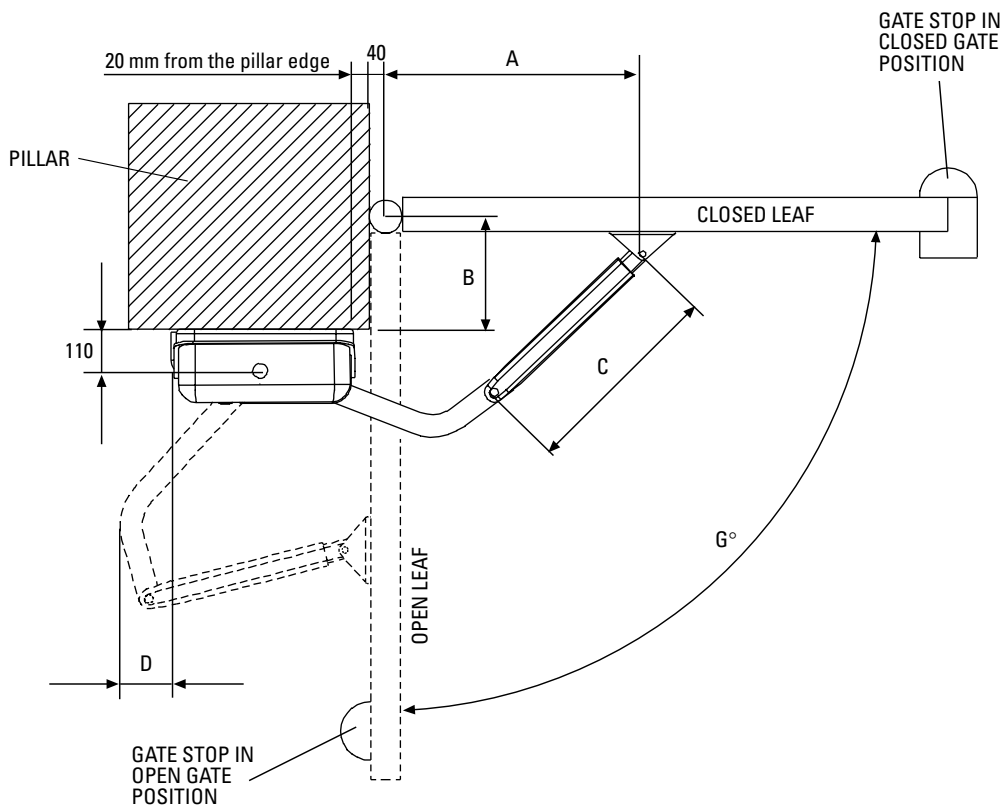

➤ **PIC. 8**

ELECTRICAL CONNECTIONS TO THE ELPRO 13 CEI PROGRAMMER

Before making any connections, study the enclosed electrical diagrams carefully.

IMPORTANT: The whole electrical system must be earthed (Pic. 9); **DO NOT CUT** the electric cable for installation requirements; **CUT OFF** the 230 V power supply (line switch not connected. (Pic. 9), during the electric wiring installation and connection phase.

- **Power supply, electric motor and flashing light** connections are made with electric cables with a section of 1.5 mm² for a maximum distance of 50 m. For distances of over 50 metres, we recommend using electric cables with a section of 2 mm².
- **For limit switches, photocells, pushbuttons and accessories** use cables with 1 mm² wires (Pic. 9)

IMPORTANT: PERFORM A RISK ANALYSIS IN COMPLIANCE WITH EN 12445 AND EN 12453 STANDARDS AND INSTALL THE NECESSARY SAFETY DEVICES. THE FOLLOWING FIGURE PROVIDES AN INDICATION OF THE ESSENTIAL ACCESSORIES FOR THE SYSTEM OPERATION. THE SYSTEM SHOULD BE CUSTOMIZED AT THE INSTALLER AND USER'S DISCRETION DEPENDING ON THE VARIOUS REQUIREMENTS AND CHARACTERISTICS OF THE ENVIRONMENT.

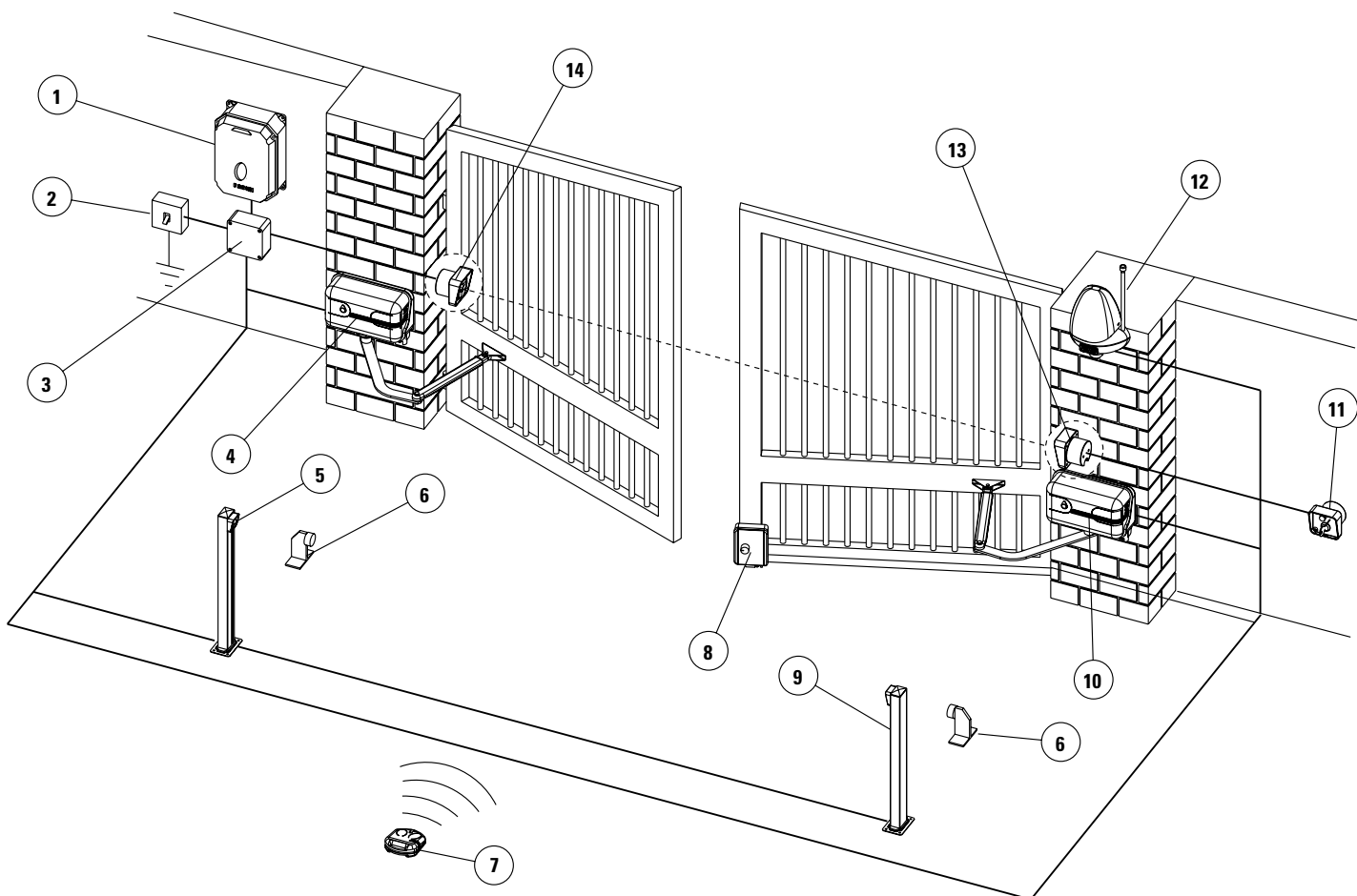

- 1) "ELPRO 13 CEI" PROGRAMMER WITH PLUG-IN JUBI 433 RADIO RECEIVER
- 2) 0.03 A MAGNETO-THERMAL DIFFERENTIAL SWITCH
- 3) JUNCTION BOX
- 4) LEFT-HAND APROLI 280/700 STRONG
- 5) PHOTOCELL TRANSMITTER POLO 44 ON POST
- 6) GATE STOP IN OPEN GATE POSITION
- 7) JUBI SMALL 433 TRANSMITTER
- 8) ELECTRIC LOCK
- 9) PHOTOCELL RECEIVER POLO 44 ON POST
- 10) RIGHT-HAND APROLI 280/700 STRONG
- 11) ENCODED KEYSWITCH PRIT 19
- 12) MIRI 4 FLASHING LIGHT FITTED WITH BIRIO ANTENNA
- 13) PHOTOCELL TRANSMITTER POLO 44
- 14) PHOTOCELL RECEIVER POLO 44

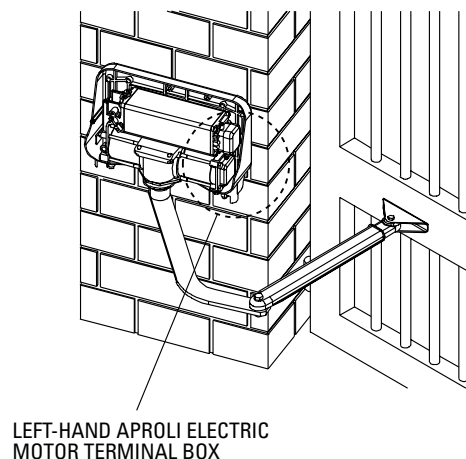

PIC. 9

Once all the electrical connections have been made, carry out the initial operation tests, adjust the motor run timer **09** for a period of 4-5 seconds more than the real gate opening time; the dwell timer **08**, and the leaf closure delay **07** (Pic. 10) In order to set automatic or semiautomatic operation, flick the Dip-switch B:

- **Automatic Operation:** with dip-switch lever No. 3 in the **ON** position, once the opening pulse has been given (contact 4 and 8 on the Elpro 13 CEI programmer terminal box), the gate opens and dwells for the time set by the potentiometer 08, then closes automatically.
- **Semiautomatic Operation:** with dip-switch lever No. 3 in the **OFF** position, once the opening pulse has been given, the gate opens, while a closing pulse must be given in order to close in (contact 5 and 8 on the Elpro 13 CEI programmer terminal box).
- **Radio Contact:** contact 7 and 8 on the Elpro 13 CEI electronic programmer terminal box (Pic. 10), the automation reverses the movement that it is carrying out upon every pulse from the keyswitch, the transmitter or the wall push buttons (it is advisable to read the instructions leaflet enclosed with the electronic programmer carefully).

WARNING: If the electric motors have insufficient drive power due to shortage of electric current, add two 12 μ F capacitors (one for each electric motor), connecting them in parallel to the individual electric motor phases.

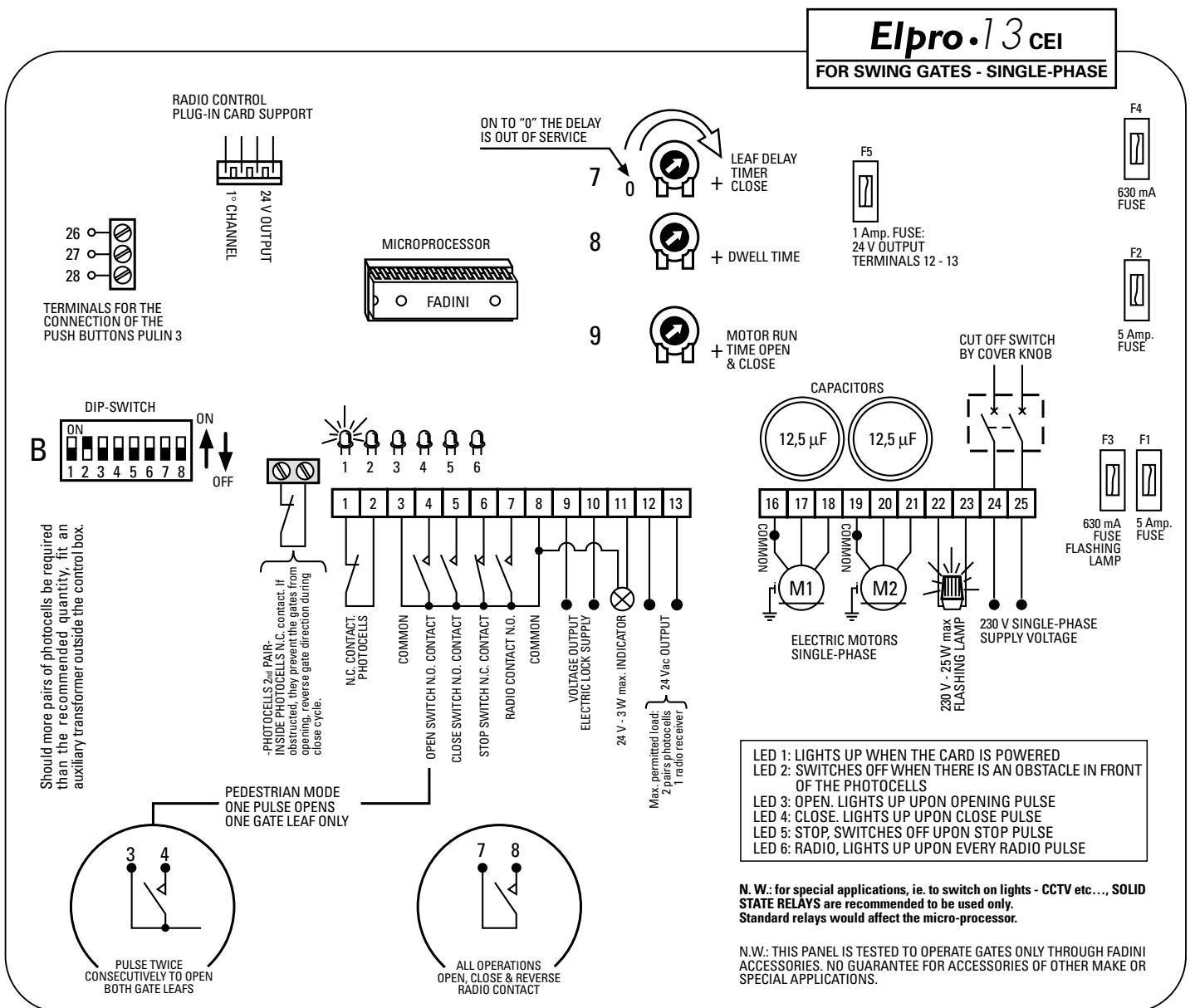

Drwg. No. 2014

FEATURES OF THE ELECTRONIC PROGRAMMER ELPRO 13 CEI FOR SWINGING GATES

All the electrical connections are to be made as per the following instructions and diagrams. Supply the terminals 24-25 with 230V - 50 Hz single phase voltage. The "red LED" switches on and stays on as long as the board is properly supplied. Through the timer No. 9 you can control the running time of the motor in both cycles, OPEN and CLOSE.

Set it so that the running time of the motor is longer than the actual travel of the gate: set the timer No. 8 -DWELL- ie. the interval between open and re-closing, so that you can meet the required interval of time. The timer No. 7 -LEAF DELAY in "close" cycle- is to be set as follows: on to "-" (less) the delay is out of service; clockwise on to "+" (more) the delay is operative.

- With the electric motor connected to terminals 19 - 20 - 21: the delay is operative in the "open" cycle, with a factory pre-set time.

- With the electric motor connected to terminals 16 - 17 - 18: the delay is operative in "close" cycle and can be adjusted through the timer No. 7 on to "less" or "more".

LOGIC OF THE ELECTRONIC PROGRAMMER: When a pulse is given, the flashing light switches on. After three seconds the motors start. During the interval before re-closing, the light stays on. When the gates are fully re-closed, the light keeps on flashing for three more seconds and then switches off automatically.

The 3 second interval (pre-flashing) which precedes the actual start of the motors can be eliminated by means of the DIP-SWITCH "B" No.4.

LED No. 1: It switches on when voltage is supplied.

LED No. 2: "PHOTOCELLS". Normally on. It switches off when the photocells are obstructed.

LED No. 3: "OPEN". It switches on when the respective switch is activated.

LED No. 4: "CLOSE". It switches on when the respective switch is activated.

LED No. 5: "STOP". Normally on. It switches off when the respective switch is activated.

LED No. 6: "RADIO". It switches on whenever a pulse is given, either from remote control, keyswitch or push buttons.

DIP-SWITCH B SETTING IN ELPRO 13 CEI

N° 1 OFF = PHOTOCELLS. NO STOP IN OPEN CYCLE. REVERSE/CLOSE

N° 2 OFF = REMOTE CONTROL. REVERSE

N° 3 OFF = NO AUTOMATIC RECLOSING

N° 4 OFF = NO PRE-FLASHING

N° 5 OFF = REMOTE CONTROL. NO STOP AND HOLD AS LONG AS BUTTON DOWN. IT OPENS STRAIGHT AWAY

N° 6 OFF = BOTH LEAFS ARE OPERATED

N° 7 OFF = S. R. P. OUT OF SERVICE

N° 8 OFF = LEAF DELAY OPEN CYCLE.
ONE STARTS BEFORE THE OTHER

N° 1 ON = STOP DURING OPEN CYCLE

N° 2 ON = NO REVERSE DURING OPEN CYCLE

N° 3 ON = AUTOMATIC RECLOSING

N° 4 ON = PRE-FLASHING

N° 5 ON = STOP AND HOLD AS LONG AS THE BUTTON IS KEPT DOWN

N° 6 ON = PEDESTRIAN. ONE LEAF ONLY GATES IN CLOSE POSITION

N° 7 ON = S. R. P. IN SERVICE GATES IN CLOSE POSITION

N° 8 ON = NO LEAF DELAY BOTH MOTORS START TOGETHER

LAMP ON = GATE OPEN
LAMP FLASHES SLOWLY = GATE OPENING
LAMP FLASHES FAST = GATE CLOSING
LAMP OFF = GATE CLOSED

1) It is advisable not to expose the control box directly to weather conditions; if mounted outside, a suitable enclosure is recommended to protect it from sunshine and rain.

2) Bridge terminals 1 - 2 if you do not require any photocells.

3) Should two sets of photocells be required, these are to be series connected to terminals 1 - 2, contact normally closed.

4) Bridge terminals 6 - 8 if you do not require any keyswitch or push buttons.

5) Fit the mains to the control box with a high sensitivity, differential, magnetic-thermal switch, 0.03 Amps.

6) OPERATING MODE WITH TWO PAIRS OF PHOTOCELLS, INDEPENDENT FROM EACH OTHER

Dip-switch No. 1 set to OFF, connect the pair of photocells that are inside the property to the terminals marked "2nd pair".

The second pair always stops the gate in open cycle in case of an obstacle.

During close cycle the second pair reverses the gate direction.

7) NOTE WELL

FAULT FINDING:

- Check supply voltage with a tester: it must be 230 V, single-phase.

- Check the high voltage fuses.

- Check the low voltage fuses.

- Check if the photocell contacts are normally closed.

- Check voltage from the control box to the electric motor(s): power might have dropped.

- The section of the electric cables to the motor(s) must not be less than 1.5 mm².

- Connect the other pair to the terminals 1 - 2

This pair performs in the standard pre-set mode, ie:

no stop during open cycle, REVERSING GATE DIRECTION DURING CLOSE CYCLE.

Terminals to stay linked out should the second pair of photocells not be used, and set the desired operating mode through Dip-switch No. 1.

* 24 V ~ output. Terminals 12 - 13. It can supply power for 2 pairs of photocells plus 1 radio receiver.

Terminal 11 provides a power output for a lamp. 24 V - 3 W max.

Flashing lamp output. Terminals 22 - 23. Maximun available power 25 W max.

FEATURES AND TECHNICAL SPECIFICATIONS

"Elpro 13 CEI" represents the latest state of the art technology for control panels. It is extremely versatile and can meet the most various requirements. It is fitted with the "Cut Off Switch" by cover knob.

It has the same functions as "Elpro 9" and incorporates additional advantages as follows: Stroke Reversing Pulse, Pedestrian Operating Mode (where one leaf only can be operated allowing people to walk in/out), STOP and HOLD function by keeping the remote control button pressed down. Further improvements can be noted in the "Elpro 13 CEI":

- Addition of a 1 Amp. fuse to the 24 V circuit as a protection for the accessories (remote control - photocells -etc.) which are connected to the terminals 12 - 13 and for the panel itself in that it can prevent short circuit during installation.
- The pulse to the electric lock is increased to 2 seconds. Releasing is so much easier as the electric lock is released with an anticipation of 100 msec. before the gate starts moving.
- A 24 V - 3 W lamp indicates gate operations (Gate CLOSED = Lamp OFF - Gate in OPEN cycle = Lamp flashes slowly - Gate OPEN = Lamp stays ON without flashing - Gate in CLOSE cycle = Lamp flashes fast).
- It provides a better switching intelligence design to enhance the reliability of the relays.
- The Motor Run Time is independent from the Leaf Delay Time in close cycle (the delay time is automatically added to the duration of the -opening time).
- The 8 Dip-switches can be arranged into any of the possible patterns to achieve the required operating modes without any risk of interference with one another.

"STROKE REVERSING PULSE" and "S.1A.P."

Set Dip-switch No. 7 to ON The "Stroke Reversing Pulse" (S.R.P.) is activated only with the gate in the CLOSE position. The pulse operates the gate in the CLOSE direction first and then immediately reverses into OPEN (This will help the gate lock to release). All the other operations will be performed in the standard way. No danger comes from the Stroke Reversing Pulse. This function remains in service with the panel set to "Pedestrian Mode". Set Dip-switch No. 6 to ON for "Pedestrian Mode" (S.1A.P.), terminals 3 - 4. Only one leaf is operated when the OPEN button is pressed down. Automatic reclosing. If the OPEN button is pressed twice in a row, both leaves are opened. The S.1A.P. function is activated only when the gate is in the fully CLOSE position. The remote control always operates both gates, terminals 7 - 8.

The box of ELPRO 13 CEI and its cover are made of weather-proof, shock-resistant plastic material which has a degree of protection equalling IP 437. The cover is fitted with a knob of quick response in case of an emergency by cutting off the voltage supply.

MANUAL RELEASE

The Aproli 280/700 Strong manual release makes it possible to move the gate manually, in the case of a power failure or during the initial manual opening and closing tests. The **manual release lever – S** can be accessed by opening the **protection cover** with the customized key. Lower the lever in order to release the gate (Pic. 11).

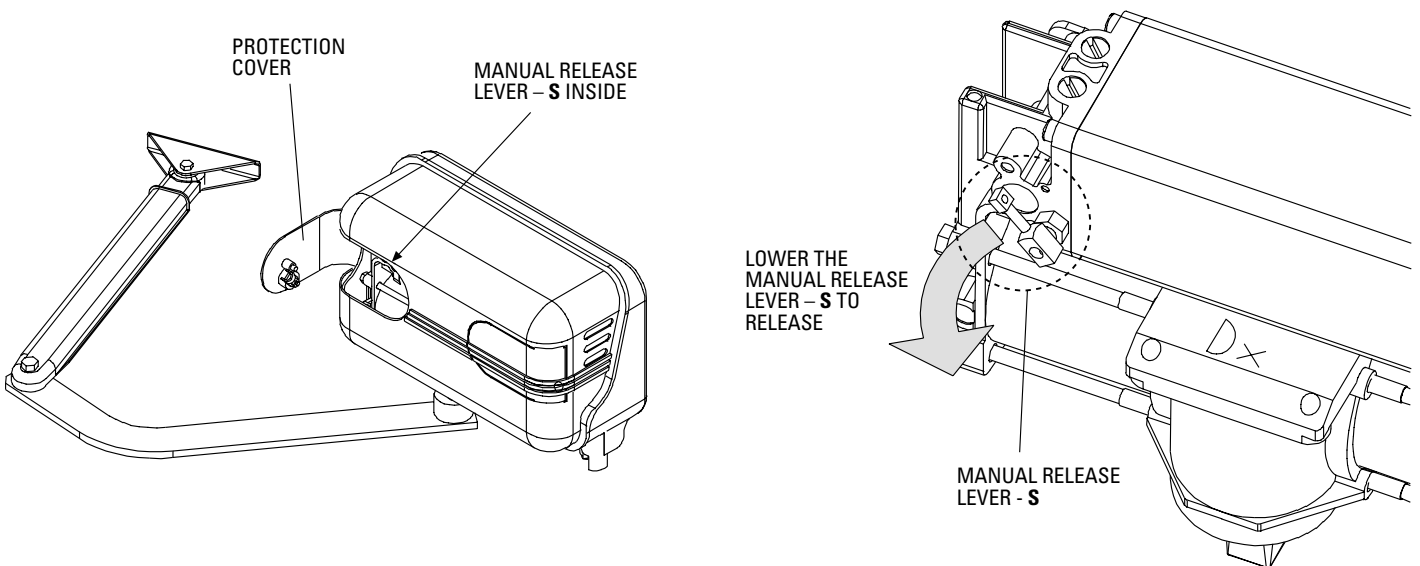

➤ **PIC. 11**

ADJUSTING THE LEAF DRIVE FORCE

During the initial manoeuvre operations it will be necessary to calibrate the opening and closing drive force that each individual Aproli 280/700 Strong exercises on the leaves; it is therefore necessary to remove the **protection cover** (Pic. 12), firstly using the customized key on the cover, thereby exposing the automation and the individual pressure regulators that can be adjusted using a flat screwdriver.

NOTE: during factory production, the two hydraulic pressure regulators on each individual Aproli 280/700 Strong are distinguished by different colours: on the Right Aproli and the Left Aproli, the **red regulator** adjusts the drive force of the leaf during closing, while the **green regulator** adjusts the drive force of the leaf during opening (Pic.12)

LEFT-HAND APROLI 280/700 STRONG

RIGHT-HAND APROLI 280/700 STRONG

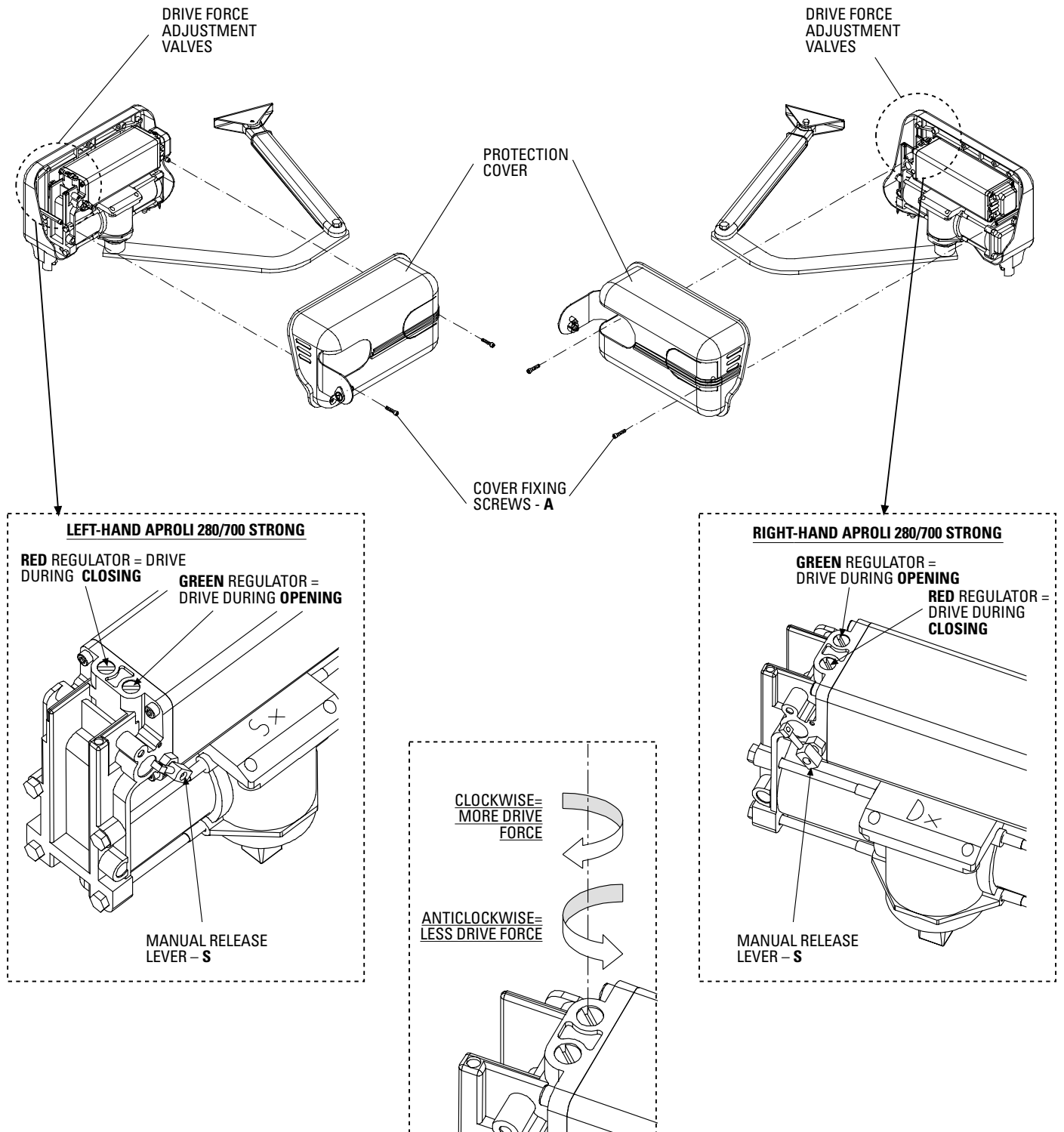

➤ **PIC. 12**

TECHNICAL DATA

ELECTRIC MOTOR

Power output.....	0.18 KW (0.25 HP)
Supply voltage / Frequency.....	230 V c.a. / 50 Hz
Absorbed current.....	250 W
Absorbed power.....	1.2 A
Capacitor.....	12 µF
Motor rotation speed.....	1'350 rpm
Intermittent service.....	S3

OIL-HYDRAULIC PUMP

Pump flow rate - P3.....	0.85 ℓ/min.
Average working pressure.....	1 MPa (10 bars)
Max. pump pressure.....	3 MPa (30 bars)
Working temperature.....	-20°C +80°C
Hydraulic oil.....	OIL A 15 FADINI by AGIP
Static weight of operator with arm.....	20 Kg
Opening time.....	23 s
Rated torque.....	137 Nm

SERVICE

Duty cycle.....	23 s Opening - 30 s Dwell - 23 s Closing
Time of one complete cycle.....	76 s
No. of complete cycles: Open - Dwell - Close.....	47 cycles/hour
No. of cycles a year, 8 hours a day.....	137'000

OVERALL DIMENSIONS

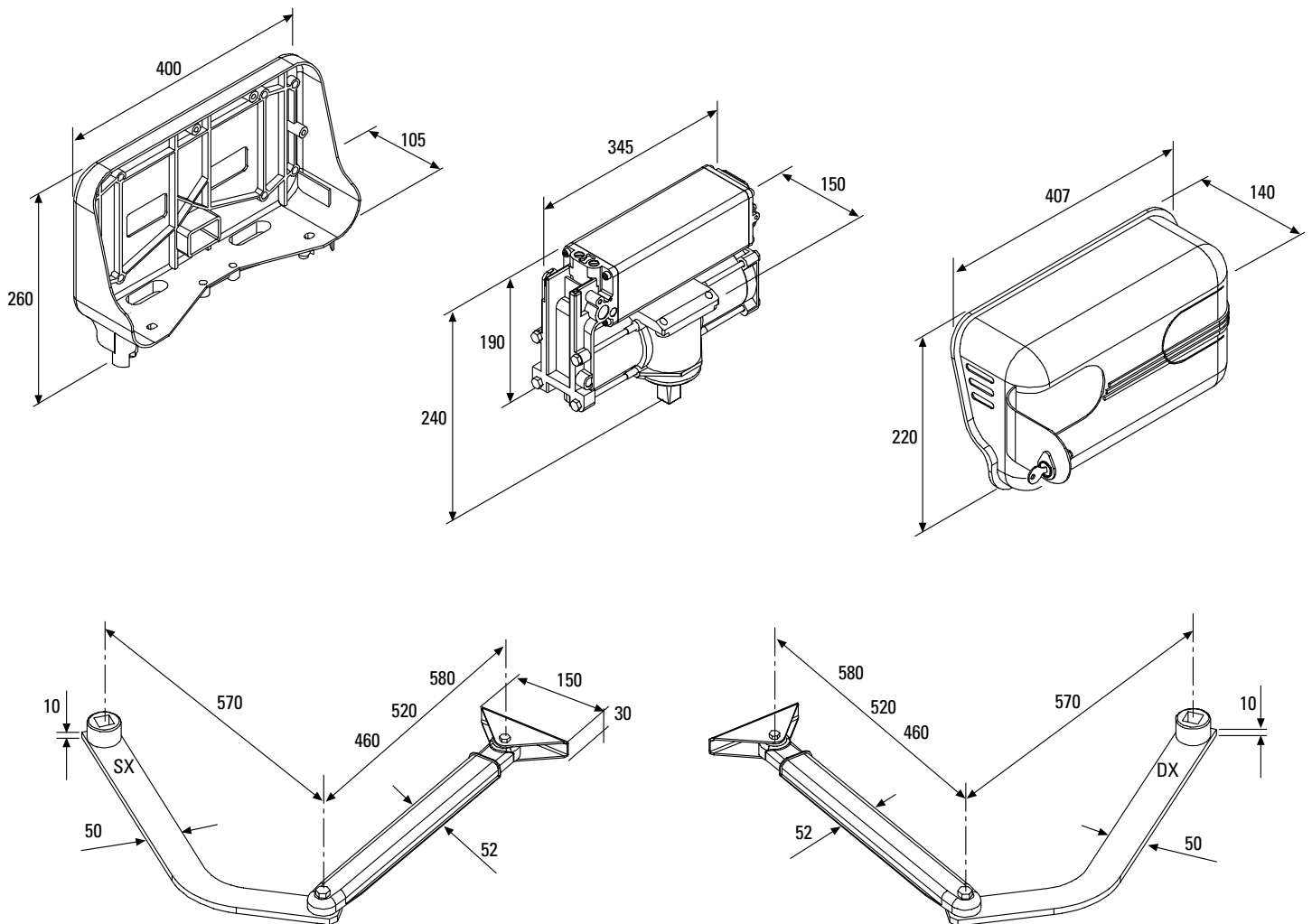

CHECKING AND MAINTENANCE:

To achieve an optimum performance and longer life of the equipment and in observance of the safety regulations, it is recommended that inspections and proper maintenance are made by qualified technicians to the whole installation ie. both the mechanical and electronic parts, as well as wiring.

- Mechanical parts: maintenance every 6 months approx.
- Electronic apparatus and safety equipment: maintenance every month.

The "CE" mark certifies that the operator conforms to the essential requirements of the European Directive art. 10 EEC 73/23, in relation to the manufacturer's declaration for the supplied items, in compliance with the body of the regulations ISO 9000-UNI EN 29000. Automation in conformity to EN 12453, EN 12445 safety standards.



**EUROPEAN MARK CERTIFYING CONFORMITY TO
THE ESSENTIAL REQUIREMENTS OF THE
STANDARDS 98/37/EC**

- DECLARATION OF CONFORMITY
- GENERAL WARNINGS
- EN 12453, EN 12445 STANDARDS
- CEI EN 60204-1 STANDARDS
- WARRANTY CERTIFICATE ON THE CUSTOMER'S REQUEST



**meccanica
FADINI®**
s.n.c.

AUTOMATIC GATE MANUFACTURERS

The growth of MECCANICA FADINI has always been based on the development of guaranteed products thanks to our "TOTAL QUALITY CONTROL" system which ensures constant quality standards, updated knowledge of the European Standards and compliance with their requirements, in view of an ever increasing process of improvement.



FADINI®
the gate opener
Made in Italy

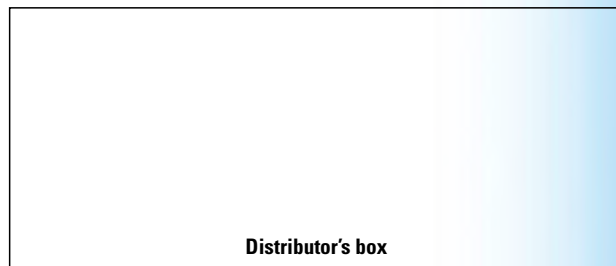

Distributor's box

The manufacturers reserve the right to change the products without any previous notice