

# Installation Manual

for  
GSM-800/ GSM Intercom System

## Installation

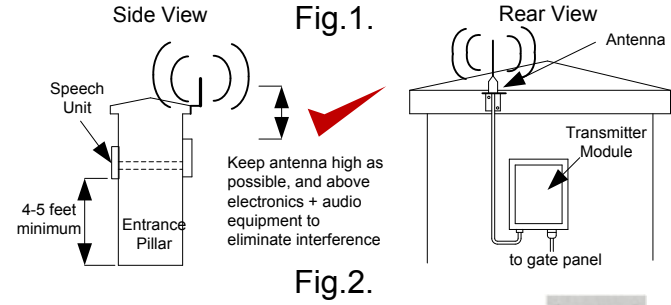

**IMPORTANT:**  
Do NOT drill holes in the top or near the top of the enclosure. Do NOT use silicone sealants!

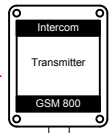

Keep short as possible, 8 meters max

## Wiring

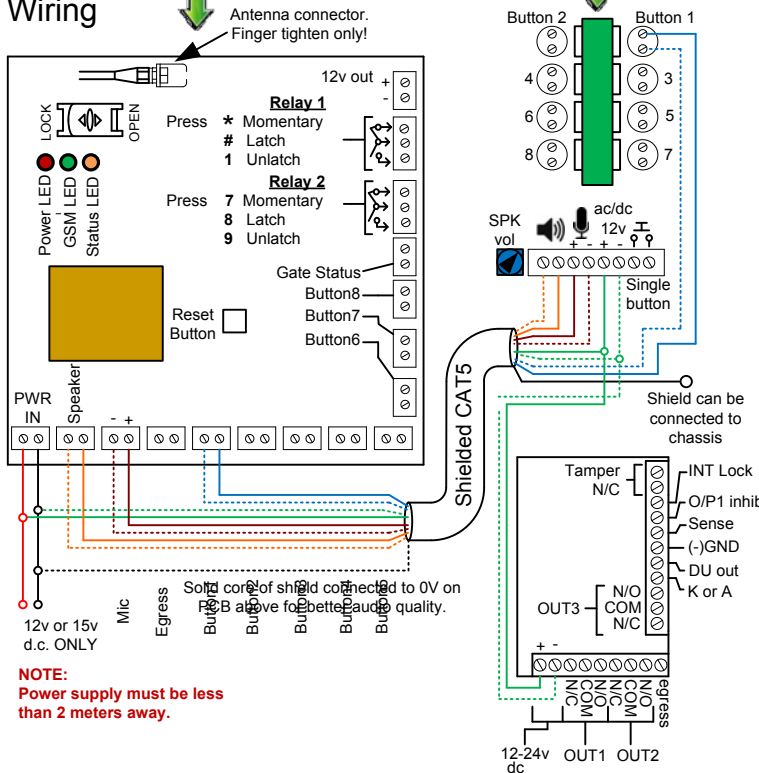

**NOTE:**  
Power supply must be less than 2 meters away.

## Installing SIM card

Before installing SIM card, switch **OFF POWER**, ensure that the card has been registered, activated, and has some calling credit. Check it works in a mobile phone first. Ensure it has the pin code request disabled, and is a GSM SIM card operating on 850 / 900 / 1800 or 1900 MHz.

**IMPORTANT:**  
The SIM card holder is FRAGILE. Do NOT force. Do NOT use a screwdriver.



**WARNING:**  
Installing or removing the SIM card without first switching off the power will cause damage to this unit!

Please allow 20-30 seconds for the unit to boot up and detect the network. Once successful connection has been made, the unit will sound a confirmation tone and the status LED will begin flashing. If there is a fault or problem, the unit will emit a series of beeps or warning tones.

## Programming

Programming is carried out by sending SMS texts to the unit.

1) First check reception. Send the following SMS to the unit... **\*20#**

The unit should reply SIGNAL LEVEL = ?  
Where ? will be between 1 and 31  
Below 14 can cause problems with relay operation, or no voice from the gate to the house. Take action to improve reception.

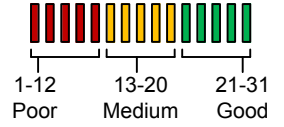

2) Program the numbers you wish the unit to dial when the call button is pressed, up to a maximum of 3 numbers. Each SMS must start with the pass code, default 1234, in the following format \*12\*1234#, followed immediately by a command. E.g to program the telephone number 987654321, enter the following SMS..

**\*12\*1234#111987654321#**

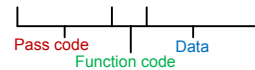

Up to 3 numbers can be sent together in a single SMS as follows..

**\*12\*1234#111tel.number1#112tel.number2#113tel.number3#**

111 = Telephone number 1  
112 = Telephone number 2  
113 = Telephone number 3

Note: If using more than 1 button panels, further dialling out numbers can be programmed as follows.. With this format being used up to 8 buttons.

### Button 2..

121 = Telephone number 1  
122 = Telephone number 2  
123 = Telephone number 3

### Button 3..

131 = Telephone number 1  
132 = Telephone number 2  
133 = Telephone number 3

3) It is recommended to change the "no answer" time if there is more than 1 number stored. This stops the unit ringing a number after a set time, and can be used to prevent voicemail answering the call. Send the following SMS..

**\*12\*1234#52??#** (?? can be 2 digits from 10-99 seconds, default is 20).

## Caller ID access control Programming

The unit can allow up to 100 telephone numbers to be stored, for users to be able to ring the system for automatic entry. This uses caller ID like a phone to determine the identity of the caller. When a recognised number calls the unit, it will trigger output 1 or 2 and hang up without answering the call.

First, the unit must know what country it is operating in.

1) Program the country code as follows..

**\*12\*1234#71??#**

Where ?? can be 1-3 digits long. For USA, enter 1 as the country code. For UK, enter 44 and so on. Do not use any leading zeros.

2) Enter the telephone numbers required to have access control. Do not enter country code, just the complete number as you would dial it, as follows..

Programming telephone number 987654321 to have access by caller ID...

**\*12\*1234# 72 1 987654321#**

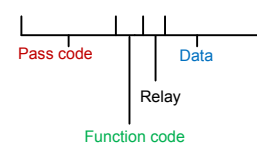

Up to 3 numbers can be sent together in the same SMS. Just add 72 then the number of the relay, 1 or 2, then the phone number followed by # each time. The pass code only needs to be put at the beginning of each new message.

**USA customers** - For some networks, you may need to enter the numbers with the long distance 1 before area code, then the number. Try with and without this to see which method works for your network.  
E.g. 1-702-555-1234

**Please note:** Even if the unit has been programmed to dial out to a number, and you also want this number to have access by caller ID, then you must also enter it again under the 72 feature as described above.

## Additional Programming Parameters

Code	Description	Default
01????#	Change programming password.	1234
02????#	Change access control password (allows users not in caller ID list to call intercom and use pass code to activate relay).	5678
03????#	Change monitoring mode password (dial to listen in mode)	1212
1nn*#	Delete a button calling number, where <b>nn</b> = number ie.11,12 or 13.	N/A
3?#	Speaker volume. Where ? = level 0 - 3	3
4?#	Microphone volume. Where ? = level 0 - 3	3
51?#	Relay 1 time. Where ? = 1-9999 seconds.	1 sec
50?#	Relay 2 time. Where ? = 1-9999 seconds.	1 sec
53??#	Max call time. Where ??? = 005-999 seconds (3 digit code)	60 sec
55??#	Max monitoring time (for listen in mode when calling the intercom) 00-60 mins. 00 = no limit.	10 min
57??#	Unit can call or SMS service number by set duration to prevent SIM card deactivation if seldom used. 00-60 days. 00 = no inform.	00
58?#	Choose between scheduled call to service number or send SMS to service number. ?=1 for SMS, 2 for call.	1
77number#	Store service number to receive scheduled SMS or call from intercom.	N/A
77*#	Delete service number.	N/A
65?#	Dial in mode for withheld numbers or non stored numbers. 1 = answer the call & wait for pass code. 2 = answer the call & automatically activate 2 way speech.	1
73??#	Delete phone number for caller ID access.	N/A
73*#	Delete all phone numbers for caller ID access.	N/A
999#	Restore defaults	N/A
*21#	Check stored numbers. Note: no pass code needed for this command. O = dial out number. I = Dial in number.	N/A

## Sending SMS Commands

All of the features shown on the Android app are also available for non Android users, or non smart phone users. You can simply send the same SMS commands manually to the intercom as detailed below...

### RELAY 1

- \*33\*5678# Momentary trigger output relay (default user pass code 5678)
- \*34\*5678# Latch output relay (default user pass code 5678)
- \*35\*5678# Un-latch output relay (default user pass code 5678)

### RELAY 2

- \*36\*5678# Momentary trigger output relay (default user pass code 5678)
- \*37\*5678# Latch output relay (default user pass code 5678)
- \*38\*5678# Un-latch output relay (default user pass code 5678)

- \*20# Check reception level of intercom.
- \*21# Check stored numbers. Unit will reply with list of stored numbers. I = dial in number. O = dial out number.
- \*22# Check gate / door status. Unit will reply Relay = On/Off, Detect = On/Off

## SIM cards & Credit

Please note that if you are using a Pay&Go or Pre-pay SIM card, which requires topped up occasionally, most network providers provide a feature called Auto Top Up. This allows you to register the SIM card on their web site, and create a payment method. When the credit runs low, the network will automatically top up your SIM card, so that you don't have to worry about running out. Contact your network provider in your country for more information or register with them online.

## Fault finding and FAQ's

### Q. The unit will not power up. No LEDs on.

A. Check power supply voltage is within 11.5V-15.5V DC.

### Q. The unit powers up but there is a bleeping from the door station.

A. This means the unit is not able to detect the network for some reason.  
 -Check the SIM card is activated and has calling credit.  
 -Power off the unit, remove the SIM and check it in a mobile phone to verify it can make a call.  
 -Check the SIM does not ask for a PIN code when put in a phone. If it does, then disable the PIN code request.  
 -Check the SIM is a standard GSM SIM, not 3G or 4G only SIM. If you are unsure, contact your SIM card provider to verify. Frequency of operation should be any one of the international quad band standards, 850 / 900 / 1800 / 1900 MHz.  
 -Check the reception is good. Poor reception is not sufficient.  
 -Check the antenna has been mounted as high as possible, not near large metal objects, or wet green shrubs etc.  
 -Check the antenna connection. Visually inspect that the centre pin inside the antenna is intact, and has not been pushed back inside the fitting.

### Q. The unit calls the first number, but there is not enough time to answer before it diverts to the next number.

A. Increase the no answer time as per programming instructions.

### Q. The unit calls the first number but voicemail comes on before it can ring the second number.

A. Decrease the no answer time as per programming instructions.

### Q. The caller ID part does not work.

A. Be sure to program the caller ID part under 72 feature. If your number is a private or number withheld, then it will not work.

### Q. There is no audio from the gate, but the person at the gate can hear ok.

A. This can be due to low reception.  
 -Check reception level by \*20#.  
 -Change SIM card if necessary to another network which may have better coverage.  
 -Purchase a high gain antenna.  
 This may also be caused by either a defective microphone, or incorrect microphone wiring, or a short circuit by whiskers between the centre core and the shielding, or excessive microphone cable length.

### Q. The audio quality that can be heard on the remote telephone is poor or humming (buzzing).

A. This can be caused by excessive cable length on the microphone cable, or by not using screened microphone cable, or by installing the GSM antenna lower than the height of the speech panel.  
 -If non of the above work, try earthing the speech panel chassis to 0V of the power supply.  
 -This is also a symptom of poor reception. Try above steps on checking and improving reception.

### Q. The \* or # key does not work when the intercom calls a phone.

A. Check if you can hear the relay clicking at the gate when the \* or # key is pressed during a call. If it can be heard, then the system is working, check wiring between the relays and the lock or gate panel. If the relays do not make a clicking sound, then check this feature on a different mobile cell phone or landline. If it works on a different phone, check the settings on the phone in question under DTMF tones. Failure of DTMF tones to operate correctly is also a symptom of low reception. Check steps above on improving reception.

# Keypad Programming (only ABK models)

## LED indicators

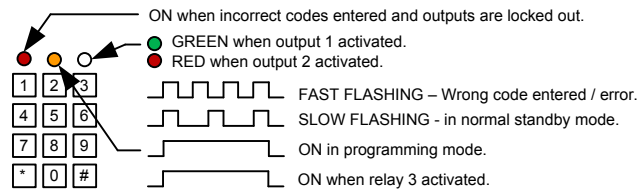

**Note: Programming can only begin 60 seconds after power on.**

## Enter Programming mode

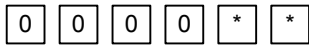

The unit is now in programming mode. Amber LED will remain ON. 0000 is default programmers code. **Note: Pressing \*\* again will exit programming mode.**

## Enter new programmers code

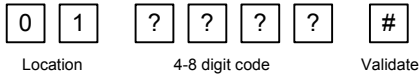

## Record or Delete user codes

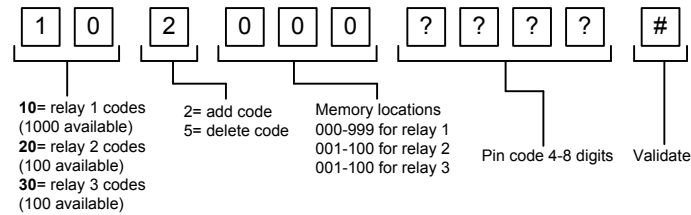

Example: Add user 31 to have access code 5555 operating relay 2....

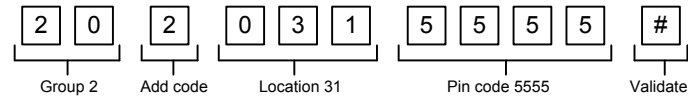

## Delete a code

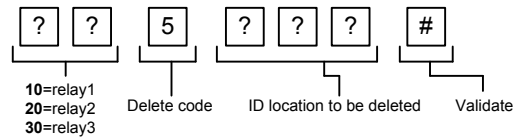

## Delete all codes in a group

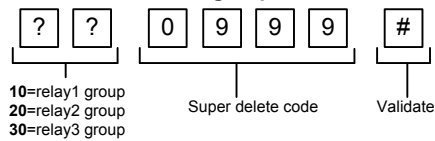

## Programming Relay output times & modes

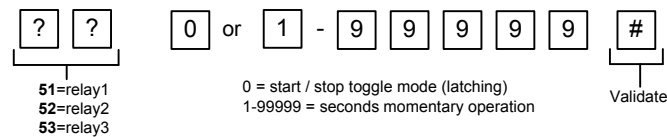

## Programming SUPER user code

Super user code is an optional feature which allows the same code to operate outputs 1, 2 or 3.

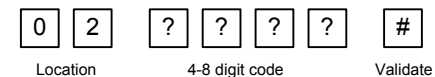

## Using super user code

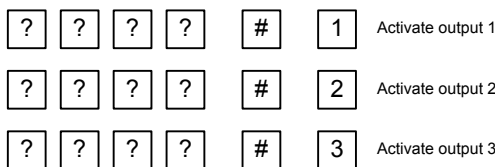

## Using standard user code

To use standard code, simply enter the 4 digit code.  
Note: Remember to exit programming mode with \*\* before testing user codes.

## Restoring defaults

While in programming mode, enter the following to delete all codes and settings apart from the Master code.. (this can take up to 2.5 minutes)...



## When the master code is forgotten...

- 1) Wire a push button (or replicate with wire link) across the EG IN terminal and (-)GND.
- 2) Switch off power for 1 minute.
- 3) Switch ON power.
- 4) during the first 60 seconds, press the EG button once to enable the function.
- 5) Enter the following code..



The keypad should now be in programming mode, ready to accept new data.

## Additional keypad information – Note: These features are not commonly used.

### EG IN (EGRESS INPUT)

Connect a push button between this terminal and (-)GND. When Egress button is pressed, output 1 will be activated for the programmed delay. Egress button is usually located inside a building and used as a push to exit.

### K or A. (KEYPAD ACTIVE OUTPUT)

An NPN transistor open collector output. It switches to (-) ground for 10 seconds on each key touching. This can be used to turn on lights, CCTV camera, or buzzer to notify a guard. The rating of this output is: Ic max: 100mA sink, Vc max: 24VDC

### DU OUT (DURESS OUTPUT)

An NPN transistor open collector output. It switches to (-) ground after the Duress Code is entered. Use it to trigger an alarm zone, or turn on a buzzer to notify a guard. Ic max: 100mA sink. Vc max: 24VDC

### DOOR SENSE

N/C connected to (-)GND, to be connected to a normally closed door contact. It can be used to generate a door open alarm or door forced open alarm.

### O/P 1 Inhibit

Normally open. When closed, this disables all codes for relay group 1 except super user and duress codes.

### Interlock Output

NPN transistor output, open collector, max power 24v dc, 100mA sink. Used to operate a door in conjunction with another keypad, or prevent two doors being opened at the same time.

### Tamper N/C

Normally closed tamper switch. This can be used in conjunction with a tamper switch on a box or enclosure to prevent tampering. This can be connected to an alarm system.

# User Manual

For GSM 800 SRS Intercom

This GSM intercom system will call up to 3 telephone numbers in sequence when the call button is pressed.

There are several modes of operation depending on how the unit has been programmed by your installer. The following instructions will assume default programming.

## Intercom calling your phone

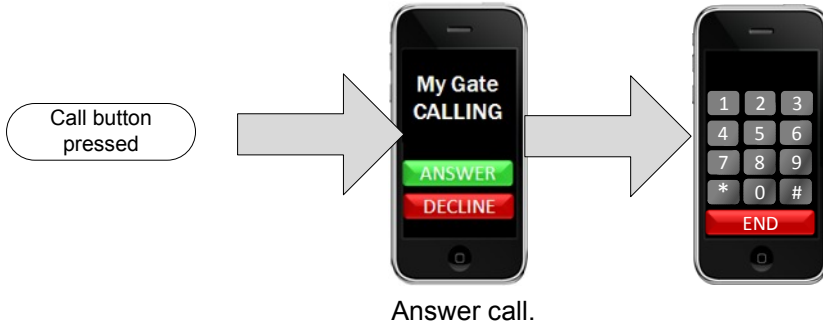

**Press \* to open  
OR  
Press # to hold open  
and  
Press 1 to release again**

(Only some gate systems allow hold open control, depending on manufacturer)

## Access Control Options

Option 1) If your number is saved inside the intercom memory, just dial it and it will activate the door or gate without answering your call. The intercom will end the call for you.



Option 2) If your number is not saved in the intercom memory, it will answer the call. Enter the code on your telephone keypad to activate the door or gate (default code 5678 shown).

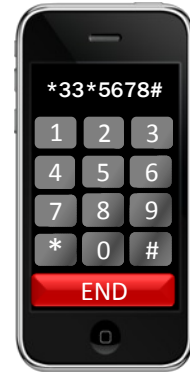

## Using the Android App

If you are using Android, you can purchase the Android app at the google play store (GSM-GATE). The app allows easy advanced control of the intercom and gates or door by the simple press of the buttons shown. The app will need configured with the SIM card phone number of your intercom before it can be used.

Once the app is installed, pressing the MENU button on your phone will display the setting screen below, where you can enter the SIM card phone number.

If your gate system is set for timed operation where it automatically closes after a preset delay, you may be able to take advantage of the latching features.

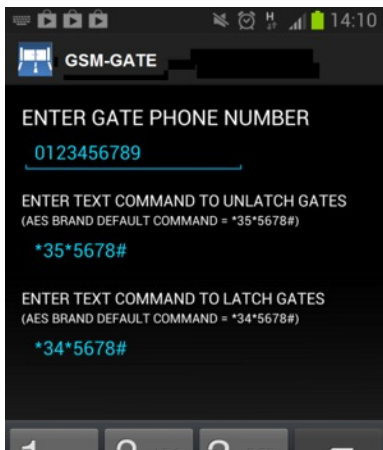

Press button to trigger gates  
(speed dials your intercom)

Hold open gates  
(sends latch SMS command)

Release / un-hold gates  
(sends unlatch SMS command)

Press for additional features  
1) Check gate open or closed  
2) Check reception level  
3) Check stored numbers

