

Installation Manual

for GSM-800/S & SK Wireless GSM Intercom System

Installation

- 1) Before you install this equipment, please read this full manual.
- 2) Ensure that there is good network reception at the location where it will be installed.
- 3) As per Fig 1, install the speech panel on the front of the pillar.
- 4) Install the antenna as high as possible on the top of the pillar to ensure line of sight in all directions for best possible reception.

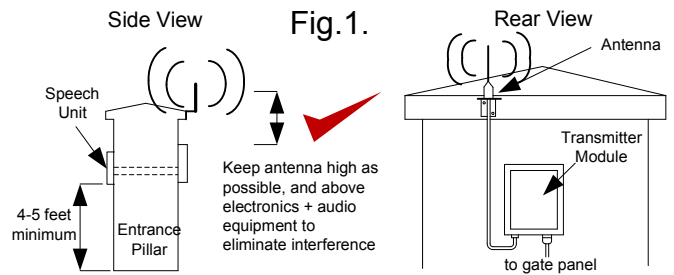

Wiring

- 5) Use multi-core cable between the speech panel and transmitter, and the screened coax cable provided for the microphone.

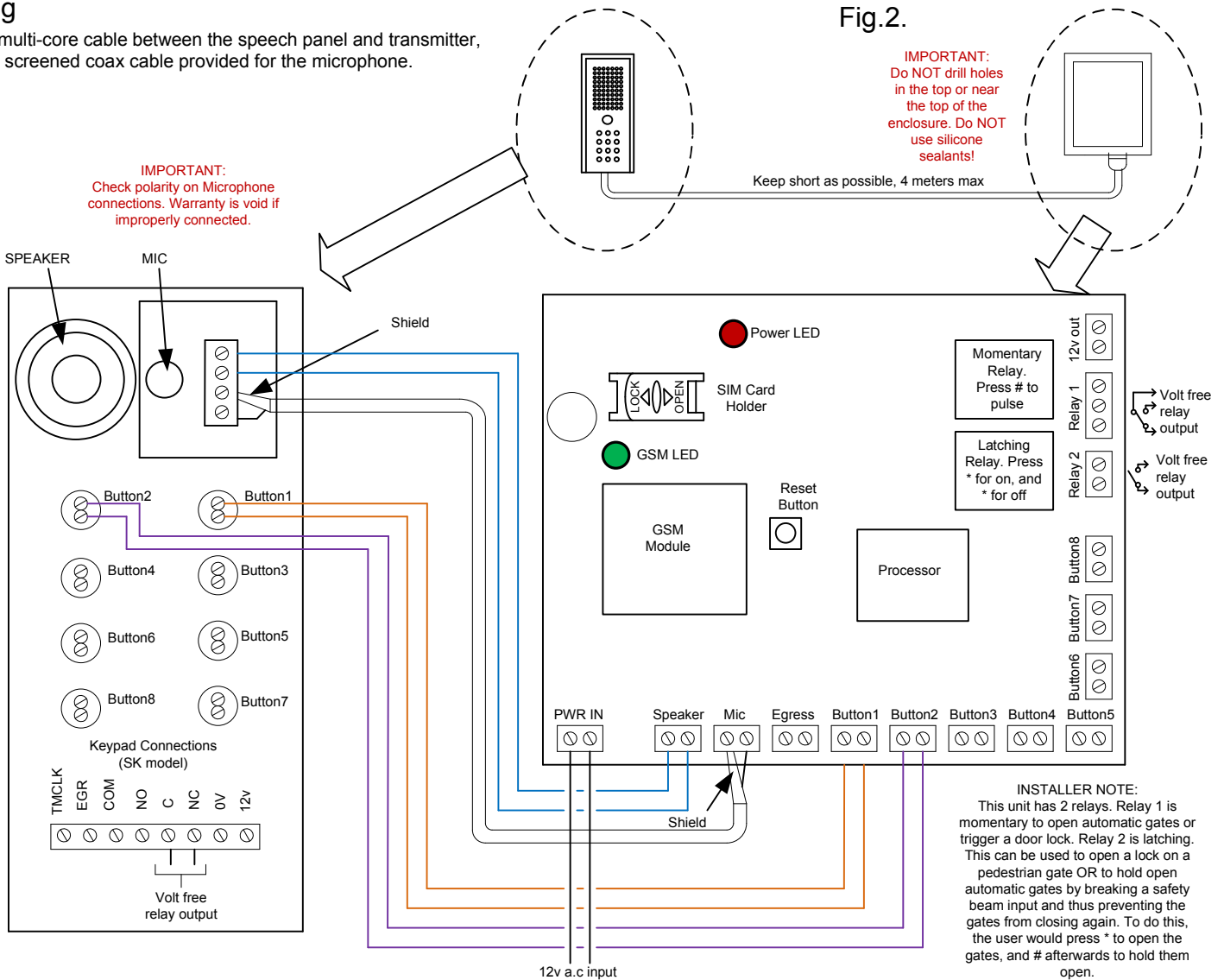

Installing SIM card

- 6) Before installing SIM card, switch **OFF POWER**, ensure that the card has been registered, activated, and has some calling credit. Check it works in a mobile phone first.

- 7) Carefully slide the SIM holder door in the OPEN direction as shown in Fig 3. Slide the SIM card into the holder, and close the door, sliding it in the LOCK position.

- 8) After a final check of wiring, switch on the power to the system. There are 2 LED indicators on the module. 1 is for power, and the other is for GSM network detect.

Please allow 20-30 seconds for the unit to boot up and detect the network. Once successful connection has been made, the unit will sound a confirmation tone and the status LED will begin flashing. If there is a fault or problem, the unit will emit a series of bleeps or warning tones.

IMPORTANT:
The SIM card holder is FRAGILE. Do NOT force. Do NOT use a screwdriver.

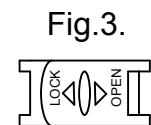

WARNING:
Installing or removing the SIM card without first switching off the power will cause damage to this unit!

Programming

This system offers 2 methods of programming. The first is DTMF, where you can program the unit from your telephone keypad, and the second is by SMS text messaging.

DTMF Method

9) Call the SIM card telephone number. The device will answer the call and you will hear a bleep.

10) Enter programming mode by pressing..

* 1 2 * 1 2 3 4 # (1234 is default password)

A successful pass code will produce a single long tone. A failed attempt will produce 3 short bleeps.

11) You may now program up to 3 telephone numbers per button, into memory for the unit to dial when each call button is pressed.

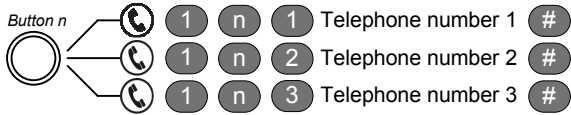
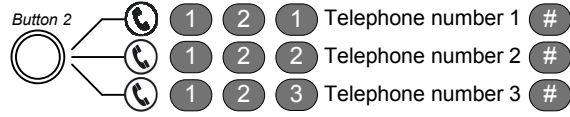
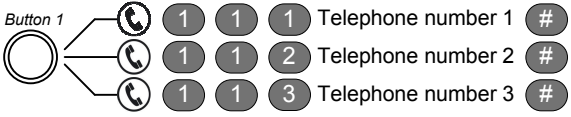

N = button number.
Replace n with button number 1 up to 8

12) It is recommended to change the "no answer" time if there is more than 1 number stored for any single button. This stops the unit ringing a number after a set time, and can be used to prevent voicemail answering the call if there is no answer at the first number.

5 2 ? ? #

(?? = 10-99. This is 10-99 seconds and may need to be adjusted. Default = 20 seconds)

Additional DTMF Features...

13) The following list contains the complete list of parameters that can be set by programming..

Change programming password (default 1234)

0 1 * ? ? ? ? #

Change door/gate open password (default 5678)

0 2 * ? ? ? ? #

Change relay 1 activation key

6 1 ? # (? = 1-9, * or #. Default = *)

Microphone volume

4 ? # (? = 1-4, default = 3)

Speaker volume

3 ? # (? = 1-4, default = 3)

Change relay 2 activation key

6 2 ? # (? = 1-9, * or #. Default = #)

Max call time

5 3 ? ? ? # (?? = 005-999, default = 60) Must use 3 digits

Restore Defaults

9 9 9 #

Relay 1 activation time

5 1 ? # (? = 1-9, default = 1. Note 1=0.5sec)

Access Control by Phone

14) The GSM-800 range can allow users to gain access from their mobile phone by two methods, 1 – Caller ID recognition to open the door or gate at no call cost to the user, and 2 – by password mode.

For the caller ID feature, use the following commands to program the unit..

Add a number (up to 100 numbers)..

7 2 Telephone number #

Delete a number..

7 3 Telephone number #

To delete all numbers..

7 3 * #

Insert international country code (1-3 digits)

7 1 Country code #

Any numbers programmed will now automatically open the gate/door when they ring the intercom SIM card number. Please note, if you have stored your number in this "white list" and still wish to access programming mode to make further adjustments, you will need to withhold your number before dialling the unit. E.g. in the UK, dial141 then the SIM number.

SMS TEXT Method

Most of the features programmable by DTMF can also be done by SMS, and the code is the same. The text message should start with the programming pass code, then the function command. If successful, the unit will send a SMS text reply with the detail which was sent.

For example..

To program telephone numbers for button 1, enter the following..

*12*1234#111Telephone1#112 Telephone2#113Telephone3#

If successful, you will receive the following text reply..

*12*1234#111Telephone1#112 Telephone2#113Telephone3#

Example 2: You wish to change the ringing time between numbers..

*12*1234#5215#

Pass code Parameter Value

You can follow this process for all parameters that are listed under DTMF section. Follow the same procedure. Note that BLUE is the pass code, GREEN is the function code, and RED is the specific value or data that you require.

Note: The SMS programming has an additional feature. It allows checking of the reception level by the following..

*20#

You will receive the following reply..

Signal level = 4

1=poor, 4=strong

Should a command be typed incorrectly, or an incorrect parameter entered, you will receive a reply with the string you entered, and an ERROR message just after the point in the text where the error occurred.

Keypad Programming (SK model only)

For most installations, it is sufficient to add a single keypad code for all users. On the keypad, enter...

The unit is now in programming mode. Sounder & LED will pulse

??? is your new user code.

Changing Programmers Code...

While in programming mode, enter the sequence shown. 0 is the location of the master code. ??? will be your new master code.

* is to exit programming mode.

Operation and Testing

- 15) Press a call button on the speech panel. You should hear a tone. The unit will ring the first telephone number programmed for that particular button.
- 16) Answer the call and check for two way voice. Activate the relay by pressing the * key and hang up.
- 17) To open the gate/door by password, ring the unit. If the number is not stored in the access control section, then the unit will answer the call. Enter *33* password # to activate the relay (default password = 5678).

Troubleshooting

Q: The unit continually beeps when powered up.

A: The SIM card is not inserted properly, or the SIM card is not activated.

Q: The unit powers up, but when I call the SIM card number, I get a network error message.

A: Check the antenna connection. Is there poor reception on site? Is the antenna vertically mounted and situated as high as possible and away from large metal objects? Check the SIM card in a mobile phone. Can it make and receive calls?

Q: Reception is good, my SIM works on a mobile phone, but the unit does not work.

A: Check if the SIM is data enabled. If so, ask your network provider to disable this feature.

Q: I am having trouble programming using DTMF.

A: In areas of poor reception, it can be difficult for a unit to decipher the DTMF tones. Try programming it from a landline instead, or use SMS programming.

Q: When I press the call button, it stops ringing the first number before I have a chance to answer it.

A: Change the parameter 52 to a larger value.

Q: When there is no answer on the first number, voicemail picks up the call and it will not ring the second number.

A: Change the parameter 52 to a smaller value.

Q: I have stored my number in the list under feature 72 for automatic access by caller ID. I wish to make programming changes but cannot access the engineering features.

A: Withhold your number before dialling the unit. In the UK, this is done by entering 141, then the SIM card number.