

Installation Manual

Installation

- 1) Before you install this equipment, please read this full manual.
- 2) Ensure that there is **good** network reception at the location where it will be installed.

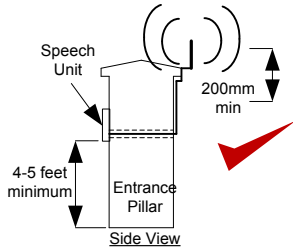

- 3) For medium or low reception areas, to reduce audio interference on a call, install an optional external antenna. Ensure it is kept as high as possible, and ABOVE all electronics.

Wiring

- 4) Carefully follow the wiring instructions. Additional wiring suggestions for electric strike lock and magnetic lock are shown overleaf.

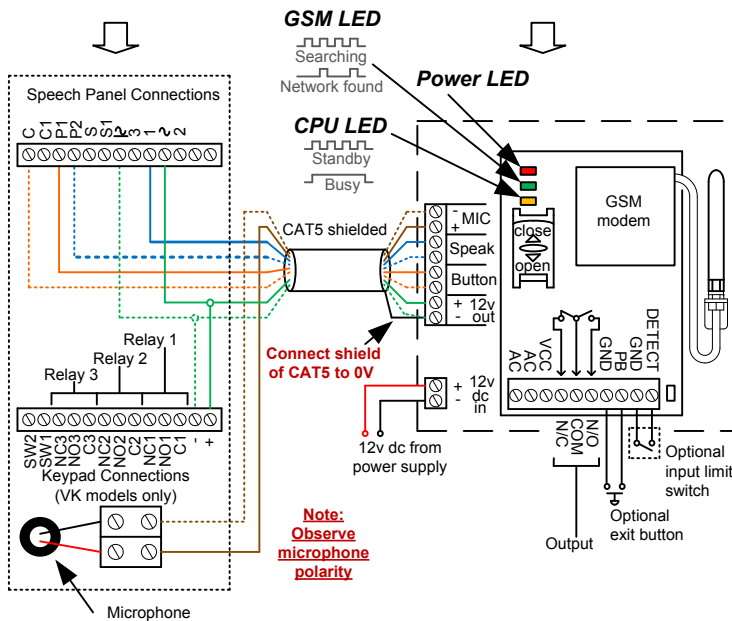
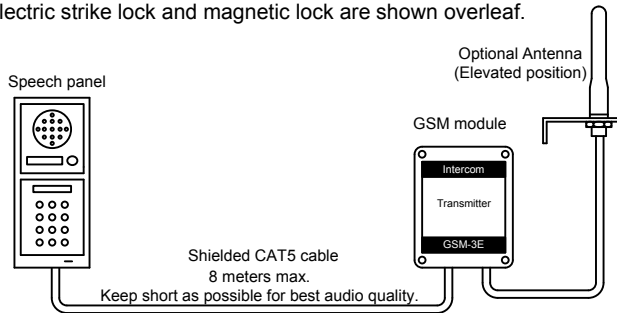

SIM card

- 5) Register your SIM card with the network, and check it works in a mobile phone first. If you are using a Pre-pay or Pay&Go SIM, it will need topped up first. Your SIM should be GSM compatible.
- 6) Ensure the **power is OFF** before inserting the SIM card.
- 7) **Carefully slide the SIM holder** in the OPEN direction, insert the SIM, and slide in the CLOSED direction to lock it in place. **Do NOT Force or use a screwdriver!**
- 8) After a final check of wiring, switch on the power.
- 9) Allow 20-30 seconds for the unit to boot up and detect the network. Once successful connection has been made, the unit will sound a confirmation tone and the status LED will begin flashing.

If there is a fault or problem, the unit will emit a series of bleeps or warning tones. If this occurs, check...

- 1) That the SIM card has been activated and has credit.
- 2) That the SIM card does not require a PIN code, disable this in a phone.
- 3) That the SIM card can make and receive a call on a phone.
- 4) If the SIM card was purchased with a phone, that it is not locked to that phone. Call the network operator to check.
- 5) Switch off power, remove and reseat the SIM card and try again.

Programming

Programming is best done by SMS text. It can also be done by DTMF from a normal telephone.

- 1) First check reception. Send the following SMS to the unit... ***20#**

The unit should reply SIGNAL LEVEL = ?
Where ? will be between 1 and 31

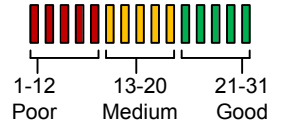

Below 14 can cause problems with relay operation, or no voice from the gate to the house. Take action to improve reception.

- 2) Program the numbers you wish the unit to dial when the call button is pressed, up to a maximum of 3 numbers. Each SMS must start with the pass code, default 1234, in the following format ***12 *1234#**, followed immediately by a command. E.g to program the telephone number 0987654321, enter the following SMS..

***12 *1234#110987654321#**
Pass code Function code Data

Up to 3 numbers can be sent together in a single SMS as follows..
***12 *1234#11tel.number1#12tel.number2#13tel.number3#**
11 = Telephone number 1
12 = Telephone number 2
13 = Telephone number 3

- 3) It is recommended to change the "no answer" time if there is more than 1 number stored. This stops the unit ringing a number after a set time, and can be used to prevent voicemail answering the call. Send the following SMS..

***12 *1234#52??#** Where ?? can be 2 digits from 10-99 seconds, default is 20.

The unit can allow up to 100 telephone numbers to be stored, for users to be able to ring the system for automatic entry. This uses caller ID like a phone to determine the identity of the caller. First, the unit must know what country it is operating in.

- 4) Program the country code as follows..

***12 *1234#71??#** Where ?? can be 1-3 digits. For uk, insert 44, for Ireland 353. Do not use any leading zeros.

- 5) Enter the telephone numbers required to have access control. Do not enter country code, just the complete number as you would dial it..

***12 *1234#720987654321#** Up to 3 numbers can be sent together in the same SMS. Just add 72 then the number, then # each time. The pass code only needs to be put at the beginning of each new message.

Additional Programming Parameters

Code	Description	Default
01????#	Change programming password.	1234
02????#	Change access control password (allows users not in caller ID list to call intercom and use pass code to activate relay).	5678
03????#	Change monitoring mode password (dial to listen in mode)	1212
1n*#	Delete a button calling number, where n = number 1,2 or 3.	N/A
3?#	Speaker volume. Where ? = level 0 - 4	3
4?#	Microphone volume. Where ? = level 0 - 4	3
51?#	Relay time. Where ? = 1-9999 seconds.	1 sec
53??#	Max call time. Where ??? = 005-999 seconds (3 digit code)	60 sec
55??#	Max monitoring time (for listen in mode when calling the intercom) 00-60 mins. 00 = no limit.	10 min
57??#	Unit can call or SMS service number by set duration to prevent SIM card deactivation if seldom used. 00-60 days. 00 = no inform.	00
58?#	Choose between scheduled call to service number or send SMS to service number. ?=1 for SMS, 2 for call.	1
77number#	Store service number to receive scheduled SMS or call from intercom.	N/A
77*#	Delete service number.	N/A
65?#	Dial in mode for withheld numbers or non stored numbers. 1 = answer the call & wait for pass code. 2 = answer the call & automatically activate 2 way speech.	1
73??#	Delete phone number for caller ID access.	N/A
73*#	Delete all phone numbers for caller ID access.	N/A
999#	Restore defaults	N/A
*21#	Check stored numbers. Note: no pass code needed for this command. 0 = dial out number. 1 = Dial in number.	N/A

Remember to begin each new SMS with pass code *12*1234#
Note: DTMF Programming is done by calling the unit, & entering the pass code first, then after a long single confirm tone, commands can be entered. A fault is indicated by 3 short bleeps.

Additional Wiring Information

A/C Strike Lock Wiring

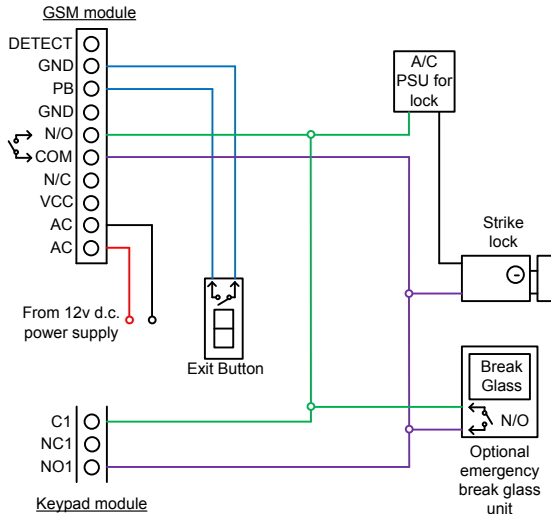

D/C Magnetic Lock Wiring

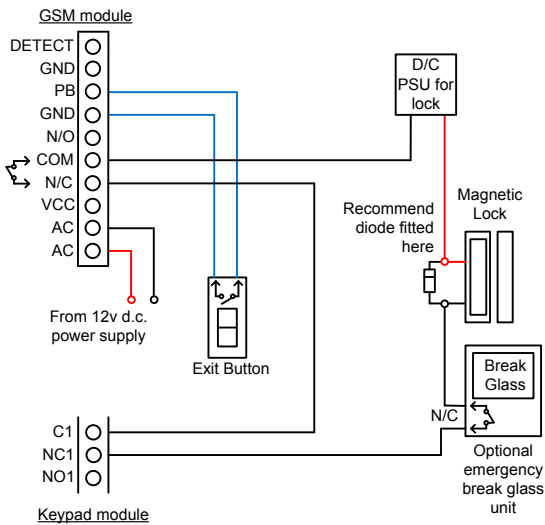

Keypad Programming (only for VK model)

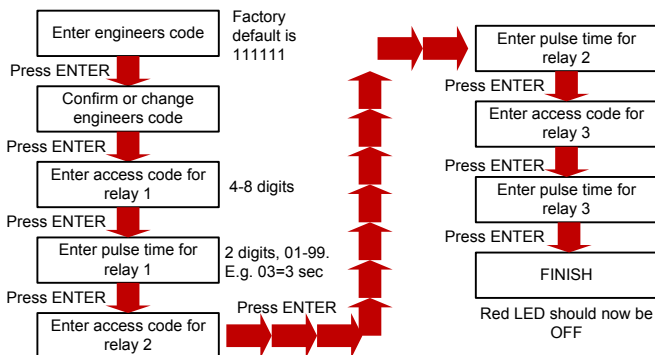

Fault finding & FAQs

Q. The unit will not power up. No LEDs on.

A. Check power supply voltage is within 11.5V-12.5V DC.

Q. The unit powers up but there is a bleeping from the door station.

A. This means the unit is not able to detect the network for some reason.
 -Check the SIM card is activated and has calling credit.
 -Power off the unit, remove the SIM and check it in a mobile phone to verify it can make a call.
 -Check the SIM does not ask for a PIN code when put in a phone. If it does, then disable the PIN code request.
 -Check the SIM is a standard GSM SIM, not 3G or 4G only SIM. If you are unsure, contact your SIM card provider to verify. Frequency of operation should be any one of the international quad band standards, 850 / 900 / 1800 / 1900 MHz.
 -Check the reception is good. Poor reception is not sufficient.
 -Check the antenna has been mounted as high as possible, not near large metal objects, or wet green shrubs etc.
 -Check the antenna connection. Visually inspect that the centre pin inside the antenna is intact, and has not been pushed back inside the fitting.

Q. The unit calls the first number, but there is not enough time to answer before it diverts to the next number.

A. Increase the no answer time as per programming instructions.

Q. The unit calls the first number but voicemail comes on before it can ring the second number.

A. Decrease the no answer time as per programming instructions.

Q. The caller ID part does not work.

A. Be sure to program the caller ID part under 72 feature. If your number is a private or number withheld, then it will not work.
 Even if you have already programmed a number to receive a call from the intercom, if you also want that number to have caller ID access, it must be programmed under the 72 feature also.
 Ensure the number is entered as you would normally dial it from another phone.
 Do not put the country code in front of the number.
 Enter the country code in which the unit is operating in separate under the 71 feature.
 International callers ringing the intercom may not work.

Q. There is no audio from the gate, but the person at the gate can hear ok.

A. This can be due to low reception.
 -Check reception level by *20#.
 -Change SIM card if necessary to another network which may have better coverage.
 -Purchase a high gain antenna.
 This may also be caused by either a defective microphone, or incorrect microphone wiring, or a short circuit by whiskers between the centre core and the shielding, or excessive microphone cable length.

Q. The audio quality that can be heard on the remote telephone is poor or humming (buzzing).

A. A small amount of GSM buzz can be considered normal on GSM intercoms, but not so much that causes inability to hear the person speaking. This can be caused by the GSM antenna being mounted too close to the speech panel or not mounted high enough.
 -Try earthing the speech panel chassis to 0V of the power supply.
 -This is also a symptom of poor reception. Try above steps on checking and improving reception.

Q. The * or # key does not work when the intercom calls a phone.

A. Check if you can hear the relay clicking at the gate when the * or # key is pressed during a call. If it can be heard, then the system is working, check wiring between the relay and the lock or gate panel. If the relays do not make a clicking sound, then check this feature on a different mobile cell phone or landline. If it works on a different phone, check the settings on the phone in question under DTMF tones.
 Failure of DTMF tones to operate correctly is also a symptom of low reception. Check steps above on improving reception. Try pressing the buttons longer when attempting to activate the gates or door.

User Manual

For GSM-3E/V & GSM-3E/VK Wireless Intercom

This GSM intercom system will call up to 3 telephone numbers in sequence when the call button is pressed.

There are several modes of operation depending on how the unit has been programmed by your installer. The following instructions will assume default programming.

Intercom calling your phone

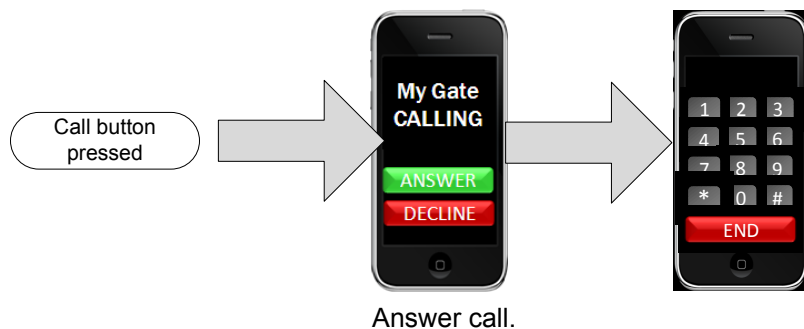

**Press * to open
OR
Press # to hold open
and
Press 1 to release again**

(Only some gate systems allow hold open control, depending on manufacturer)

Sending SMS Commands

Default pass code 5678 is shown in all examples. This may have been changed by your installer.

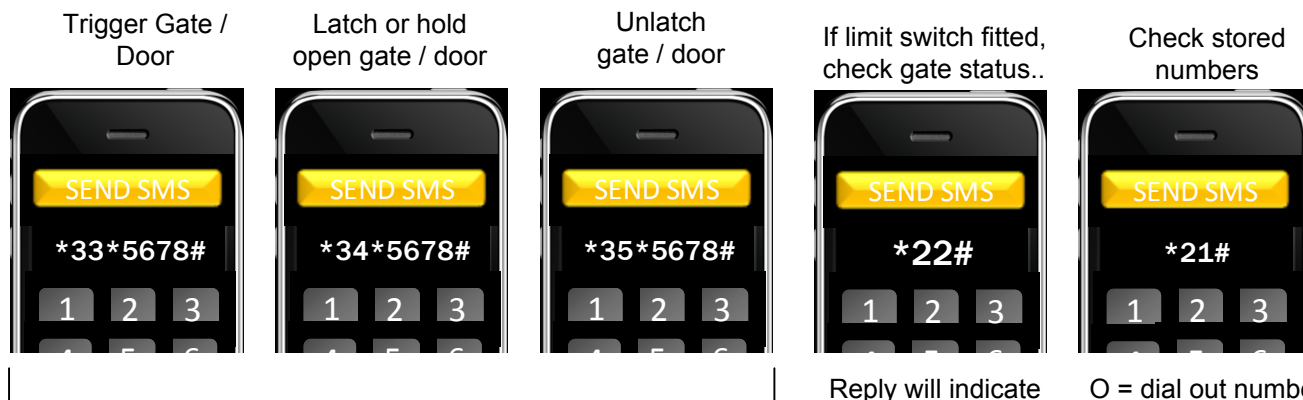

HOLD OPEN FEATURE, OR "PARTY MODE"

Some gate systems allow hold open control, depending on manufacturer. Send the following SMS commands to control the gates..

Reply will indicate opened or closed.

O = dial out number
I = Dial in number for caller ID access.

Calling the intercom options



Option 1) If your number is saved inside the intercom memory, just dial it and it will activate the door or gate without answering your call. The intercom will end the call for you.



Option 2) If your number is not saved in the intercom memory, it will answer the call. Enter the code on your telephone keypad to activate the door or gate (default code shown).