

I
FOGLIO
TECNICO

GB
TECHNICAL
SHEET

F
FEUILLE
TECHNIQUE

NL
TECHNISCHE
HANDLEIDING

D
TECHNIKBLATT

E
HOJA
TÉCNICA

P
FOLHETO
TÉCNICO

FT KIT 12

ATTENZIONE - WARNING - ATTENTION - AANDACHT - AUFMERKSAMKEIT - ATENÇÃO - ATENCIÓN

**DOCUMENTAZIONE ALLEGATA AL MANUALE MT KIT 10
PER L'INSTALLAZIONE DELLA PULSANTIERA VANDALCOM**

**DOCUMENTATION ENCLOSED WITH MT KIT 10 INSTRUCTION MANUAL
FOR INSTALLING THE VANDALCOM ENTRANCE PANEL**

**DOCUMENTATION ANNEXÉE AU MANUEL MT KIT 10
POUR L'INSTALLATION DE LA PLAQUE DE RUE VANDALCOM**

**DOCUMENTATIE BEHORENDE BIJ MT KIT 10 INSTALLATIE HANDLEIDING
VOOR HET INSTALLEREN VAN HET VANDALCOM ENTREEPANEEL**

**DOKUMENTATION IN DER ANLAGE DES TECHNISCHEN BUCHES MT KIT 10
FÜR DIE ANLAGE DER VANDALCOM TASTERPLATTE**

**DOCUMENTAÇÃO INCLUÍDA NO MANUAL MT KIT 10,
PARA A INSTALAÇÃO DA UNIDADE EXTERNA COM A BOTONEIRA VANDALCOM**

**DOCUMENTACIÓN INCLUIDA EN EL MANUAL MT KIT 10
PARA LA INSTALACIÓN DE LA PLACA DE CALLE VANDALCOM**

Postazione esterna pulsantiera VANDALCOM Art. 4877BKC

External unit: VANDALCOM entrance panel Art. 4877BKC

Poste extérieur: plaque de rue VANDALCOM Art. 4877BKC

VANDALCOM Art. 4877BKC extern entreepaneel

Aussenstation: VANDALCOM Tasterplatte Art. 4877BKC

Unidade externa: botoneira VANDALCOM Art. 4877BKC

Puesto externo: placa de calle VANDALCOM Art. 4877BKC

Assistenza tecnica Italia 0346/750090
Commerciale Italia 0346/750091

Technical service abroad (+39) 0346750092
Export department (+39) 0346750093



INVENTING INNOVATION

I CARATTERISTICHE TECNICHE

Connessione al monitor con 2 fili per audio, video, apri porta e chiamata + 2 fili per alimentazione da 1205/B.
Telecamera orientabile ad alta sensibilità con sensore CCD 1/3".
Illuminazione a LED bianchi.
Regolazione volume microfono e altoparlante.
Pulsante di chiamata in acciaio inox, telaio in alluminio pressofuso.
Dimensione scatola da incasso: 130x130x58 mm.
Dimensione posto esterno: 143x143x18 mm.

GB TECHNICAL CHARACTERISTICS:

Connection to the monitor with 2 wires for audio, video, door opening and call + 2 wires for power supply from 1205/B.
High sensitivity adjustable TV camera with 1/3" CCD sensor.
White LED lighting.
Microphone and loudspeaker volume adjustment.
Stainless steel call pushbutton, die-cast aluminium frame.
Dimensions of flush-mounted box: 130x130x58 mm.
Dimensions of external unit: 143x143x18 mm.

F CARACTÉRISTIQUES TECHNIQUES:

Connexion au moniteur au moyen de 2 fils pour audio, vidéo, ouverture et appel + 2 fils pour alimentation de 1205/B.
Caméra orientable à haute sensibilité avec capteur CCD 1/3".
Éclairage à Leds blanc.
Réglage du volume du micro et du haut-parleur.
Bouton d'appel en acier inox, cadre en aluminium moulé sous pression.
Dimensions du boîtier d'encastrement: 130x130x58 mm.
Dimension de la plaque de rue: 143x143x18 mm.

NL TECHNISCHE GEGEVENS:

Aansluitingen naar de monitor met 2 aders voor audio, video, deuropening en oproep + 2 aders voor de voeding van Art. 1205/B.
Instelbare "high sensitivity" camera met 1/3" CCD sensor.
Wit leds verlichting.
Instelmogelijkheid van het volume van zowel de microfoon als de luidspreker.
Roestvrij stalen module, gegoten aluminium frame.
Afmetingen inbouwdoos: 130x130x58 mm.
Afmetingen entreepaneel: 143x143x18 mm.

D TECHNISCHE EIGENSCHAFTEN:

Anschluss an den Monitor mit 2 Drähten für Audio, Video, Türöffnertaste und Rufton + 2 Drähte zur Versorgung von 1205/B.
Ausrichtbare hoch empfindliche Kamera mit Sensor CCD 1/3".
Weiß-LED Beleuchtung.
Einstellung der Lautstärke von Mikrophon und Lautsprecher.
Edelstahlrufftaste, Grundrahmen aus Aluminiumdruckguss.
Abmessungen des UP-Gehäuses: 130x130x58 mm.
Abmessungen der Außenstation: 143x143x18 mm.

P CARACTERÍSTICAS TÉCNICAS:

Ligação ao monitor com 2 fios para áudio, vídeo, trinco de porta e chamada + 2 fios para alimentação de 1205/B.
Câmara orientável de alta sensibilidade com sensor CCD 1/3".
Iluminação com LEDs brancos.
Regulação do volume do microfone e altifalante.
Botão em aço inoxidável, aro da botoneira em alumínio préfundido.
Dimensão da caixa de embutir: 130x130x58 mm.
Dimensões posto externo: 143x143x18 mm.

E CARACTERÍSTICAS TÉCNICAS:

Conexión al monitor con 2 cables para audio, vídeo, abre-puerta y llamada + 2 cables para alimentación de 1205/B.
Telecámara orientable de alta sensibilidad con sensor CCD 1/3".
Iluminación por leds blanco.
Regulación del volumen del micrófono y del altavoz.
Pulsador de llamada en acero inoxidable, marco en fundición a presión de aluminio.
Dimensión caja empotrable: 130x130x58 mm.
Dimensión unidad externa: 143x143x18 mm.

- I Altezza scatola da incasso
- GB Height from floor level
- F Hauteur du sol
- NL Hoogte vanaf vloerniveau
- D Abstand über dem Boden
- P Altura desde o chão
- E Altura del suelo

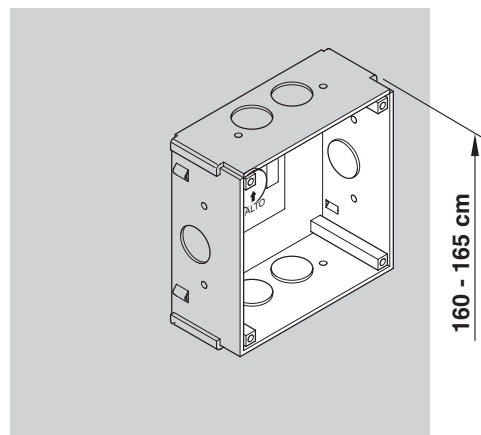

- I Montaggio lampada
- GB Lamp fixing
- F Fixage de la lampe
- NL Lamp bevestiging
- D Anbringung der Lampen
- P Fixação da lâmpada
- E Montaje de la lámpara

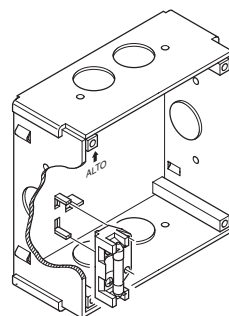

- ① Regolazioni portiere e gruppo A/V
- Ⓒ Speaker unit and A/V unit adjustment
- Ⓕ Réglage HP-micro et groupe A/V
- Ⓖ Luidspreker unit en A/V unit afregelen

- Ⓓ Lautsprecher-und A/V Einheitsregelierung
- Ⓓ Afiinação do altifalante de porta e do módulo audio/video
- Ⓔ Regulación del portero audio y del grupo A/V

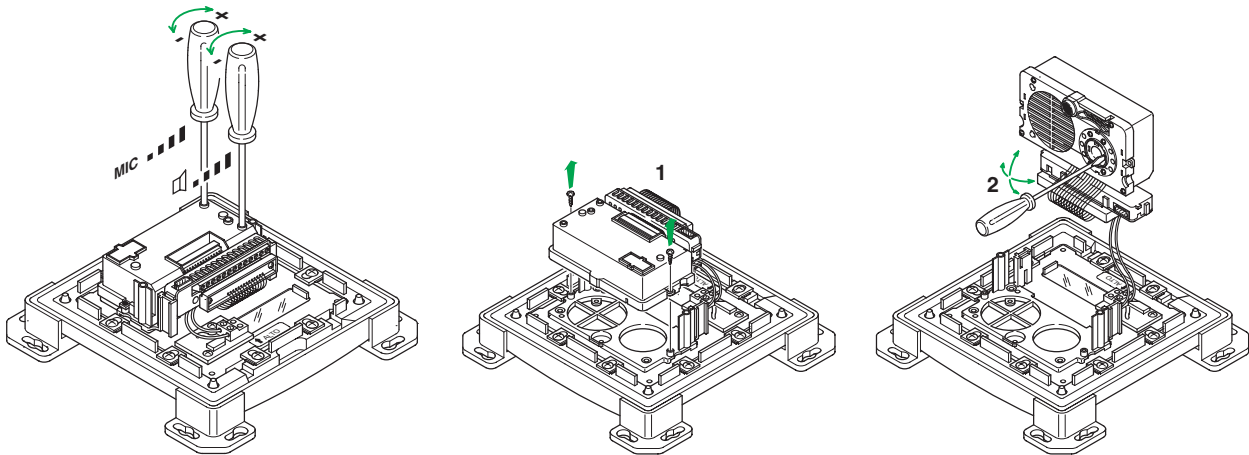

- ① Cablaggio
- Ⓒ Conductors connection
- Ⓕ Reliage des connecteurs
- Ⓖ Aansluiten van de bedrading

- Ⓓ Verdrahtung der Anlage
- Ⓓ Ligação de condutores
- Ⓔ Conexión de los cables

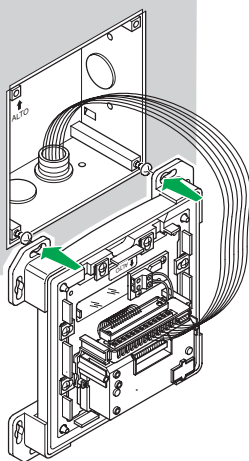

Soluzione "A"
 Solution "A"
 Solution "A"
 Mogelijkheid "A"
 Lösung "A"
 Solução "A"
 Solución "A"

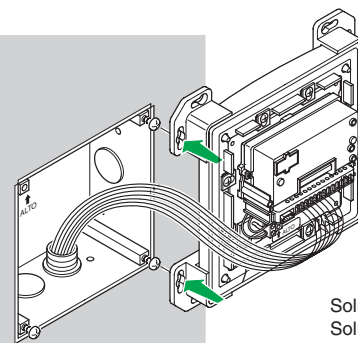

Soluzione "B"
 Solution "B"
 Solution "B"
 Mogelijkheid "B"
 Lösung "B"
 Solução "B"
 Solución "B"

- ① Montaggio cartellini
- Ⓒ Inserting / removing of nameplates labels
- Ⓕ Fixage et enlèvement des cartons porte-noms
- Ⓖ Monteren en verwijderen van naamplaatlabels
- Ⓓ Namensschild eingeben bzw herausnehmen
- Ⓓ Inserção / remoção dos porta nomes
- Ⓔ Montaje de las etiquetas porta nombres

- Ⓓ Fissaggio a muro
- Ⓒ Wall fixing
- Ⓕ Fixage au mur
- Ⓖ Muurmontage
- Ⓓ Wandmontage
- Ⓓ Fixação à parede
- Ⓔ Fijación a la pared

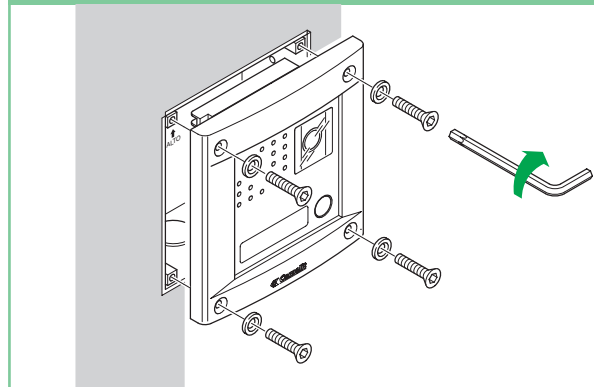
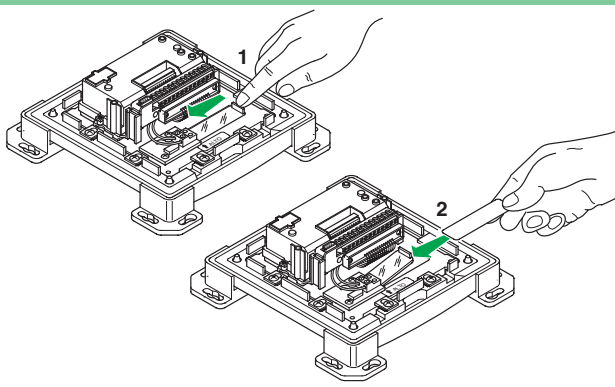

BK/01VC

- ① Schema base per kit monofamiliare Art. 8371.
- Ⓒ Basic diagram for single-family kit Art. 8371.
- Ⓕ Schéma de base du kit 1 usager Art. 8371.
- Ⓝ Bedradingschema voor enkelvoudige kit 8371.

- Ⓓ Basis-Installationsplan für kit der Einfamilienhäuser Art. 8371.
- Ⓗ Diagrama básico do kit unifamiliar Art. 8371.
- Ⓔ Esquema base para kit unifamiliar Art. 8371.

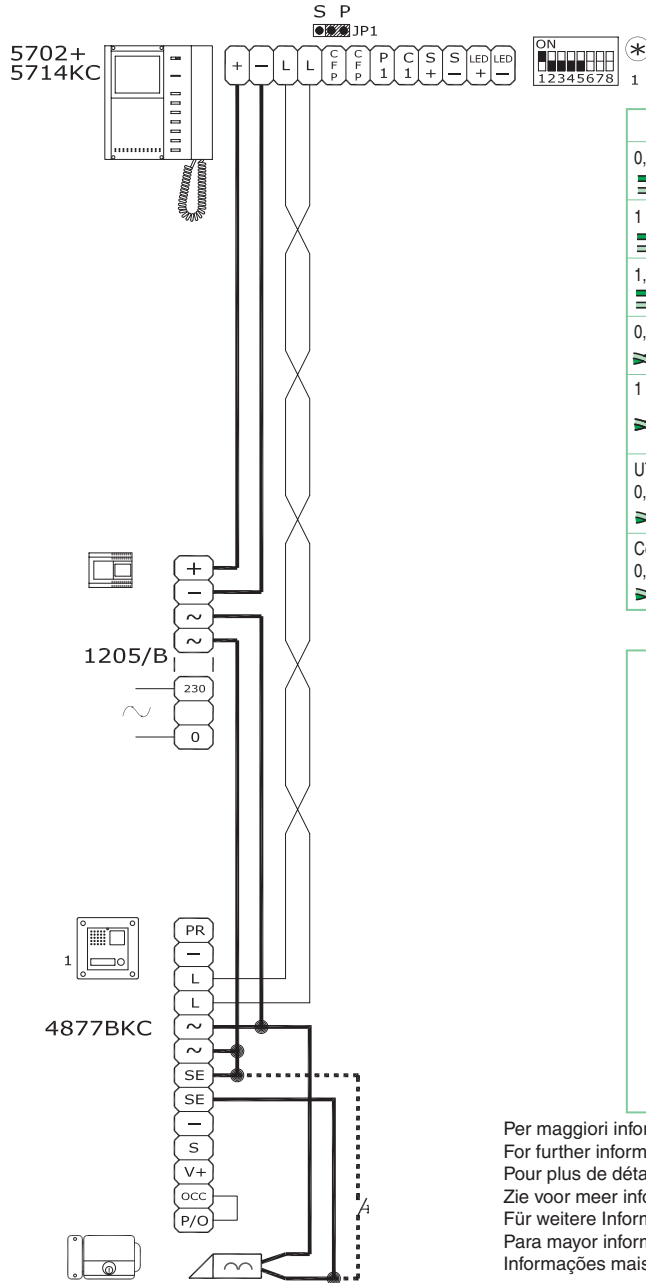

	A (max)	B (max)	C (max)
0,5 mm ² (Ø 0,8 mm - Ø 8/10)	20 m	25 m	150 m
1 mm ² (Ø 1,2 mm - Ø 12/10)	40 m	50 m	150 m
1,5 mm ² (Ø 1,4 mm - Ø 14/10)	60 m	100 m	150 m
0,28 mm ² (Ø 0,6 mm - Ø 6/10)			150 m
1 mm ² (Ø 1,2 mm - Ø 12/10)			100 m
UTP5 Cat 5 AWG 24 0,2 mm ² (Ø 0,5 mm - Ø 5/10)			150 m
Comelit Art. 4576 0,5 mm ² (Ø 0,8 mm - Ø 8/10)			150 m

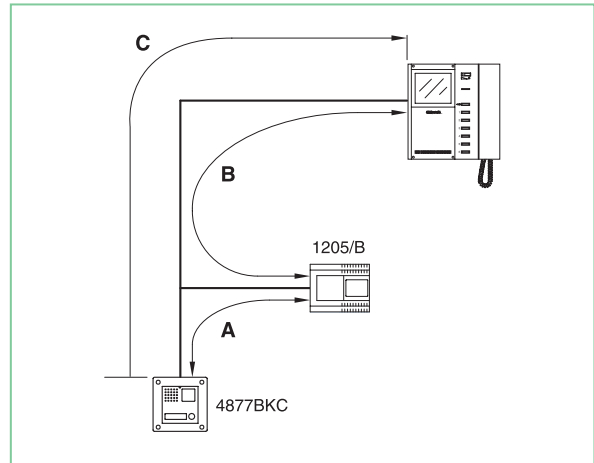

Per maggiori informazioni sulle distanze vedi MT KIT 10.
 For further information about distances refer to MT KIT 10.
 Pour plus de détails sur les distances faire référence au MT KIT 10.
 Zie voor meer informatie over de afstanden MT KIT 10.
 Für weitere Informationen zu den Abständen sind die MT KIT 10 einzusehen.
 Para mayor información sobre las distancias, véanse MT KIT 10.
 Informações mais detalhadas sobre as distâncias podem ser consultadas nas MT KIT 10.

Assistenza tecnica Italia 0346/750090
 Commerciale Italia 0346/750091

Technical service abroad (+39) 0346750092
 Export department (+39) 0346750093



[B] Comelit Belgium
 Chaussée de Ninove, 900 - 1703 Schepdaal
 (Dilbeek)
 Ninoofssesteenweg, 900 - 1703 Schepdaal
 (Dilbeek)
 Tel 02 411 50 99 - Fax 02 411 50 97
 www.comelit.be - info@comelit.be

[D] Comelit Group Germany GmbH
 Äußere Oberstraße 20
 83026 Rosenheim
 Tel. 08031 22154 11 - Fax 08031 22154 12
 www.comelit.de - info@comelit.de

[E] Comelit Espana S.L.
 Josef Estivill 67/69 - 08027 Barcelona
 Tel. +353 (0) 1 619 0204
 www.comelit.es
 info@comelit.es

[F] Comelit Immotec
 Siège :
 Parc d'activités Technologiques EUROPARC
 3 allées des Saules
 94042 CRETEIL CEDEX
 Tél : 01-43-53-97-97 - Fax : 01-43-53-97-87
 www.comelit.fr
 Comelit.NH@wanadoo.fr

[GR] Comelit Telergo Hellas
 9 Epiru str.
 16452 Argyroupolis - Athens Greece
 Tel. 210 9968605-6 - Fax : 210 9945560
 www.comelit.gr
 telergo@otenet.gr

[I] Comelit Piemonte
 Str. Del Pascolo 6/E
 10156 Torino
 Tel e Fax 011 2979330

[I] Comelit Sud S.r.l.
 Via Corso Claudio, 18
 84083 Castel San Giorgio (Sa)
 Tel. 081 516 2021 - Fax 081 953 5951
 www.comelitsud.it
 info@comelitsud.it

[IRL] Comelit Ireland
 Suite 3 Herbert Hall
 16 Herbert Street - Dublin 2
 Tel. +353 (0) 1 619 0204
 Fax. +353 (0) 1 619 0298
 www.comelit.ie
 info@comelit.ie

[NL] Comelit Nederland BV
 Aventurelrijn 220 - 3316 LB Dordrecht
 Tel 078 65 11 201 - Fax: 078 61 70 955
 www.comelit.nl
 info@comelit.nl

[RC] Comelit (Shanghai) Electronics Co., Ltd
 5 Floor No. 4 Building No.30 Hongcao Road
 Hi-Tech Park Caohejing, Shanghai, China
 Tel. 0086-21-64519192/97373527
 Fax. 0086-21-64517710
 www.comelit.com.cn
 comelit@comelit.com.cn

[SG] Comelit Group
 Singapore Representative Office
 54 Genting Lane, Ruby Land Complex
 Blk 2, #06-01 - Singapore 349562
 Tel. +65-6748 8563 - Fax +65-6748 8584
 comelit2004@yahoo.com.sg

[UAE] Comelit Group U.A.E.
 Middle East Office
 P.O. Box 54433 - Dubai U.A.E.
 Tel +971 4 299 7533 - Fax +971 4 299 7534
 www.scame.ae
 scame@scame.ae

[UK] Comelit Group UK Ltd
 Unit 4 Watchmead Welwyn Garden City
 HERTS AL7 1GX
 Tel 01707 377203 - Fax 01707 377204
 www.comelitgroup.co.uk
 info@comelitgroup.co.uk

[USA] Comelit Group USA
 250 W. Duarte Rd. Suite B
 Monrovia, CA 91016
 Tel. 626 930 0388 - Fax 626 930 0488
 sales@cyrenetworks.com