



Statement

The EB300 electric dropbolt is designed for surface mount application and the EB300VGL is designed for frameless glass door and glass wall applications.

Specification

- Fail-Safe Version (Power to Lock)
- Operating Voltage: 12 VDC
- Voltage Tolerance: $\pm 10\%$
- Current Draw: Pull in: 0.9A, Holding: 0.3A/12VDC (at 20°C)
- Door Position status output (Reed rated 0.25A/30VDC) indicates door open or closed status.
- Operating Temperature: $-10\sim+45^{\circ}\text{C}$
- Humidity: 0~95% non-condensing.
- Tested over 500000 cycles.
- Auto-relocking Time Delay : 0, 3, 6, 9 seconds
- Net Weight :
EB300: 1.1 Kg
EB300VGL: 1.7 Kg

Energy Saving Design

After the dropbolt is completely locked, the current draw changes from 0.9A to 0.3A to prolong its life.

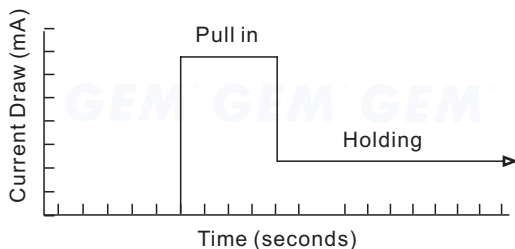

Dimensions

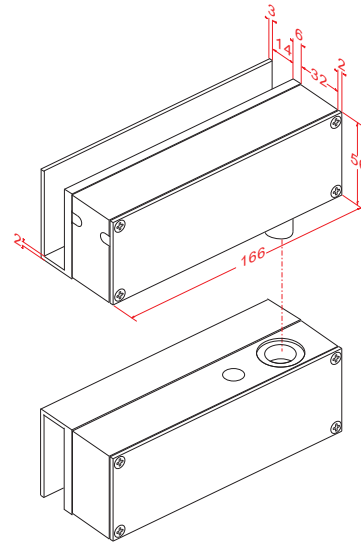

Unit: mm

Long life solenoids

The specially designed solenoid aims for strength and long life. The solenoid is guaranteed 500,000 times of operations.

Relock Time Delay

Adjustable Time Delay of 0,3,6,9 seconds with 2 way DIP switch. (Default Value: 0 sec.)

Relock time setting



0 seconds

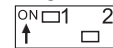

3 seconds

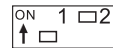

6 seconds

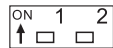

9 seconds

Vandal Resistant Circuitry

The vandal resistant circuitry means the door position sensor can't be fooled into projecting the electric dropbolt unless the door is actually closed. The reed sensor automatically disconnects after the bolt is projected to enhance security of the lock.

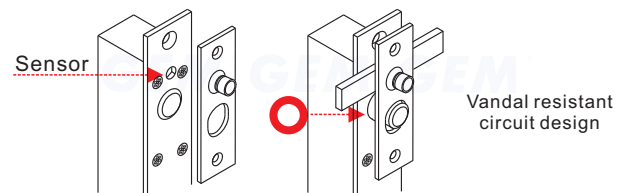

Warranty

The product is warranted against defects in material and workmanship while used in normal service for a period of 2 years from the date of sale to the original customer. The GEM policy is one of continual development and improvement; therefore GEM reserves the right to change specifications without notice.

GIANNI INDUSTRIES, INC.

● Surface Mount on Narrow Frame

The EB300 dropbolt and strike plate with complete housings are specially designed for narrow door frames.

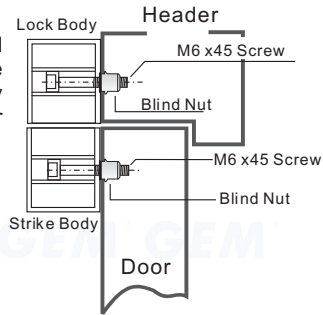

● For Full Frameless Glass doors

The EB300VGL Dropbolt and strike plate with complete housings and u-brackets are specially designed for full frameless glass doors/walls. The thickness of glass is 10~13 mm.

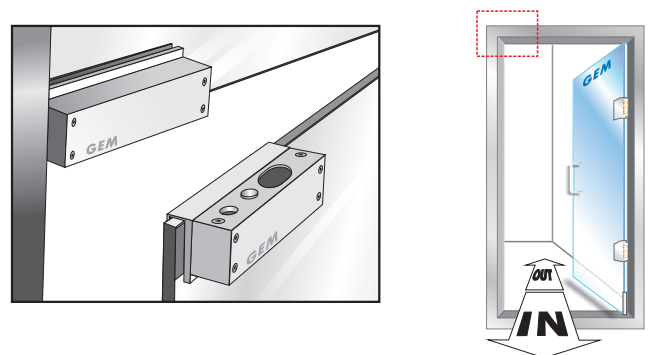
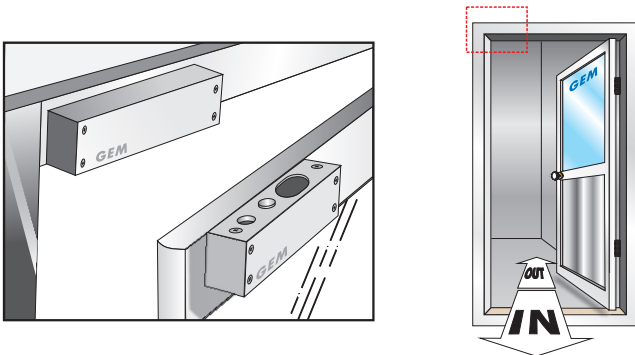
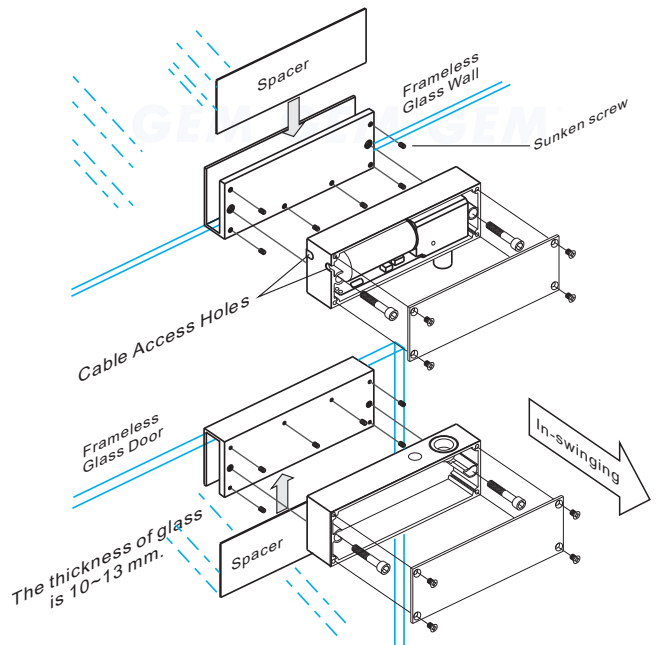
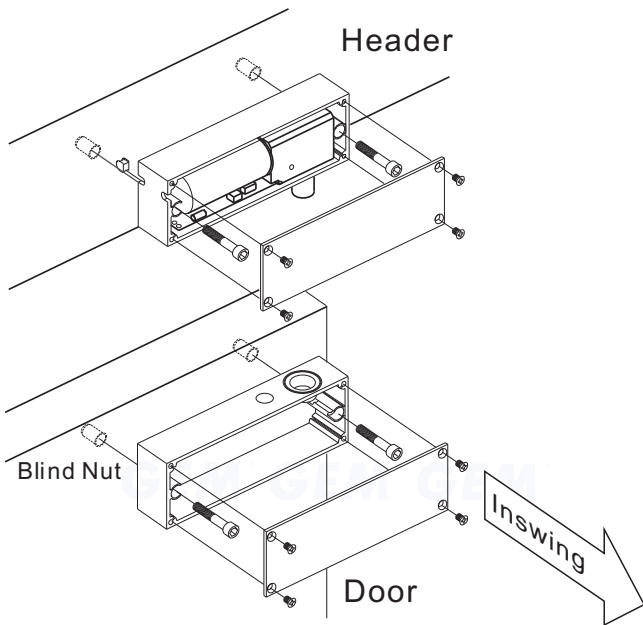
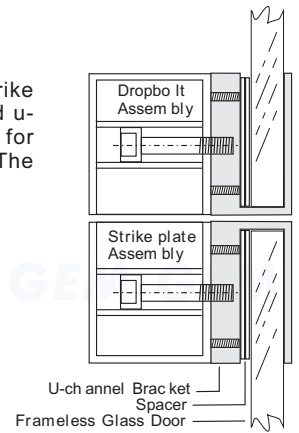

GIANNI INDUSTRIES, INC.