

FERMAX

225 Solutions

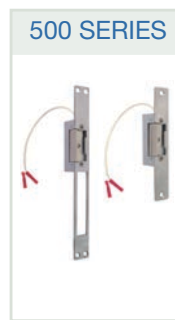

DOOR LOCK RELEASE

GENERAL CATALOGUE



WARRANTY

All Fermax products have a 24 months warranty.

Fermax obligation under this warranty, however, is expressly limited (at Fermax option) to replacing, repairing, or issuing credit for any product returned to FERMAX within 24 months from date of shipment by FERMAX.

This warranty does not cover problems arising due to causes with the equipment (for example deficiencies in installation or incorrect wiring), nor breakdowns caused by incorrect manipulation or blows.

DELIVERY

- 15 days after order confirmation and reception of payment.
- Allow 30 days for special orders.
- Every endeavour will be made by the Company to adhere to the delivery dates quoted, but such dates are only estimate and are not guaranteed neither shall they be a term of condition between the Buyer and the Company.
- The Buyer shall be responsible for arranging insurance on goods collected by their own carriers.
- Delay in delivery shall by no means entitle the Buyer to cancel the order or thereby render the Seller liable to the Buyer for any loss or expense arising from the delay unless otherwise agreed in writing.
- Ex works.

FERMAX reserves the right to modify these sales conditions. The characteristics and aesthetics of the products may be modified. The graphic representations are for informative use only.

INDEX

■	INTRODUCTION	
	1. WHAT IS AN ELECTRIC LOCK RELEASE?	2
	2. LOCK RELEASE PARTS	3
■	LOCK RELEASE SELECTION	
	1. CHOOSING THE BEST OPTION	6
	2. QUICK GUIDE	7
■	DESCRIPTION	
	1. COMPOSITION	8
	2. GLOSSARY OF TERMS	9
	3. REFERENCE TABLE	10
■	LOCK RELEASE TYPES	15
	FLUSH	16
	SURFACE	29
■	ACCESSORIES	43
	SHIELDS AND CASES. RETAINERS. CONTACT POWER SUPPLIES. CABLE CONDUITS. RELAYS.	
■	ACCESS CONTROL	51
	RF, KEYPAD AND PROXIMITY.	
■	ASSEMBLY INSTRUCTIONS	55
■	INSTALLATION/WIRING DIAGRAMS	59
■	REFERENCE INDEX	69

1. What is an electric door lock release?

Flush
Surface

The electric door lock release is a device installed in the door frame to control opening remotely.

FLUSH LOCK

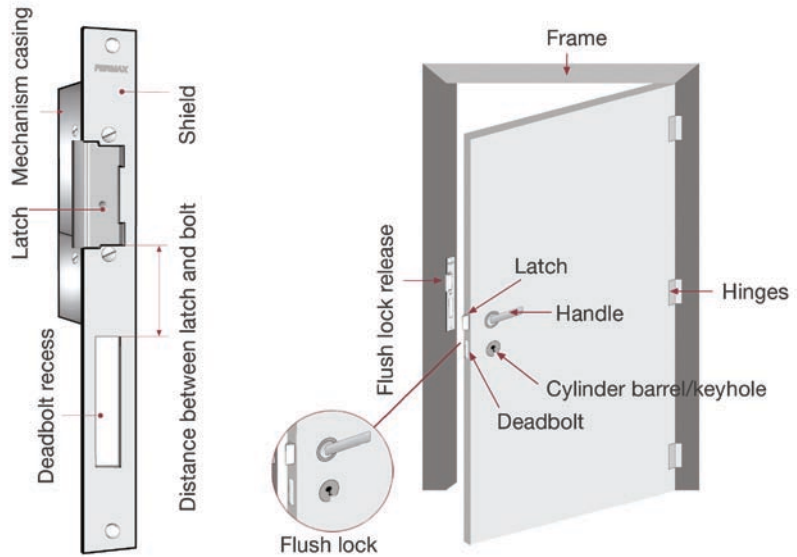

SURFACE LOCK

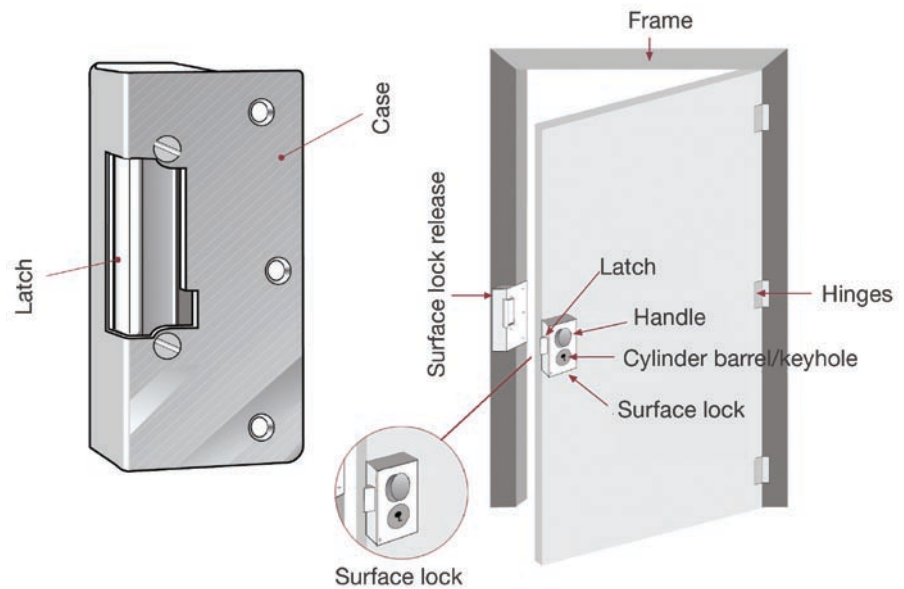

DIN STANDARD

DIN STANDARD sets the direction the door opens and designates the type of lock release installed. (See technical drawing).

- Look at the door from the side where the hinges are visible:
- . If the hinges are on the left of the observer, it is a left DIN.
 - . If the hinges are on the right of the observer, it is a right DIN.

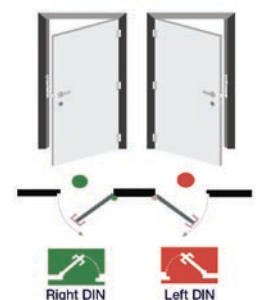

2. Lock release parts

- 2.1 Mechanisms
- 2.2 Shields and Cases

A lock release consists of an electric mechanism and a shield or case depending on whether it is flush or surface mounted.

FLUSH LOCK

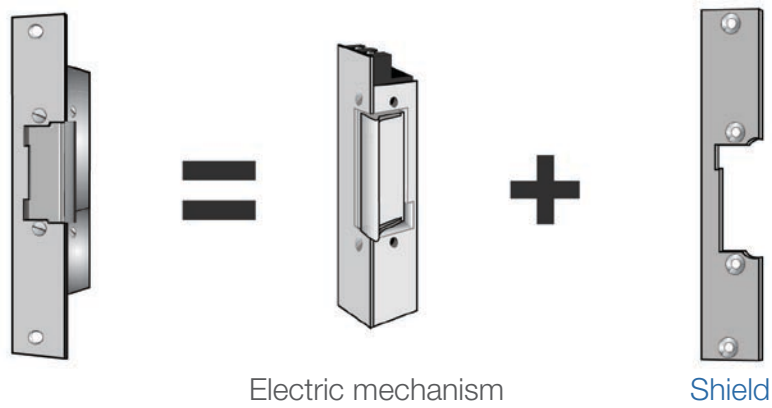

SURFACE LOCK

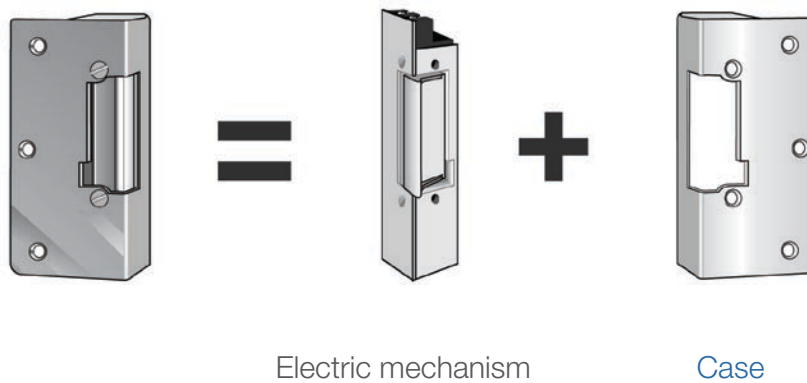

ELECTRIC MECHANISM

Part receiving power feed to open or close the door.
 Several models are available, depending on the OPERATING MODE.

SHIELD OR CASE

Metal part that converts a lock release mechanism into flush-fit (MECHANISM+SHIELD) or surface-mounted (MECHANISM+CASE).

2.1. Mechanisms

OPERATING MODES



Normal Operation - N

Allows door opening while the lock release is powered.

N	12 Vac activation
N-412	12 Vdc activation
N-424	24 Vdc activation



Automatic Operation - A or Aa

Enables door opening with a short electric pulse.

The lock release is automatically blocked when the door closes again.

A	12 Vac activation
A-412	12 Vdc activation
A-424	24 Vdc activation



Inverted operation - N-500

Allows door opening while power to the lock release is off.

N-512	12 Vdc activation
N-524	24 Vdc activation

ADDITIONAL FEATURES



Unlocking lever - D

The lock release with D in its description indicates the addition of a manual release lever which inhibits its function, allowing free access.

ND	Normal operation with release.
AD	Automatic operation with release.



Adjustable latch bolt - MAX

If the lock description contains MAX, it indicates that the latch is adjustable, allowing a perfect fit between latch and bolt in the lock, with a 4mm margin.



To order the MAX version lock release, please add an 8 to the end of the reference of the compatible lock.

2.2 Shields and Cases



SHIELDS

Used to make up lock releases that are built into the door frame.

FOR ACCESS DOORS

Wooden or metal doors	Wooden doors
 <p>S, SX P, PX P22 B22</p>	 <p>53</p>
<p><i>See dimensions on page 44 and 45</i></p>	

FOR LATCH-BOLT ENTRY DOORS



Wooden or metal doors	Wooden doors
 <p>GX M, MX L T GE</p>	 <p>1001 1002</p>

CASES

Used to make up locks to be surface mounted. There are two types of support:

VISIBLE ATTACHMENT ON FRAME



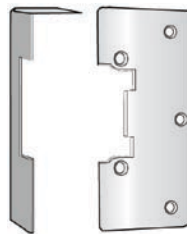

- One-piece models.
-  2001 Chrome CASE
 -  2006 Grey CASE

HIDDEN FRAME ATTACHMENT



- Two-piece models.
-  2003 Grey CASE



- One-piece models.
-  2005 Chrome CASE
 -  2007 Grey CASE

See dimensions on page 46

1. Choosing the best option for your purpose

1. SECURITY LEVEL REQUIRED. Depends on the lock resistance.

STANDARD. Lock releases are resistant to impacts of up to 260 Kg (2600N). Used to cover the basic security needs of any outdoor or indoor enclosure.

REINFORCED. Support impacts up to 800 kg (8000N). For heavily transited accesses or heavy iron or wrought iron doors.

2. DOOR LOCK TYPES FLUSH or SURFACE. FLUSH or SURFACE.

3. DOOR MATERIAL WHERE LOCK IS INSTALLED.

Material used in door: aluminium, iron, wood, wrought iron, PVC or glass.

The most commonly used frames are aluminium and wood, followed by iron.

- In wooden frames, angled locks are used. For flush mounting, use Shields: 1001, 1002 and 53.
- In aluminium and PVC frames with narrow fronts, use SERIES 410. Smaller size makes it ideal for replacement since it fits any gap and its radial latch means it turns on its own opening radius.
- In heavy iron or wrought iron doors with a lot of traffic, we recommend SERIES 500, which includes a latch bolt made entirely of steel, enabling it to withstand pressures up to 800 Kg.
- For doors located outside (fences, gates, etc.) we recommend the 620 SERIES (IP65) which keeps out moisture and dust.
- For fireproof doors the fire-resistant SERIES 520 is recommended.
- For glass doors (mainly used in commercial applications) there are surface-mounted double leaf (C SERIES) or flush mounted single leaf (CII SERIES) doors with latches adapted to this type of doors.
- If the door has a deadbolt (lock release with deadbolt lock, we will indicate that these are locking doors) the best option is to install a door release with a latch/bolt recess in European DIN format, increasing the security level of the door when it is locked.

4. IF SIGNALLING IS REQUIRED

There are lock releases with C, NO and NC contact relays (Normally Open and Normally Closed NC) to identify whether the door is open or closed, by means of a micro switch in the latch.

They allow a variety of applications for security, access control and alarm installations. This function is used, among others, in security locks (the second door or gate will not open until the first is shut). (See 3000 SERIES).

5. POWER SUPPLY

Depending on the type of power supply, there are:

DC CURRENT. Characterized by being quiet. Inverted operation electric locks (N-500) are this type.

AC POWER SUPPLY. Noisy compared with DC locks. They generally have a higher consumption and work better indoors subject to some type of pressure: wind, bolt friction, etc.

6. TYPES OF OPERATIONS REQUIRED

NORMAL operation. Power supply to open. AC or DC power feed.

AUTOMATIC operation. One energy pulse keeps it open until the door opens and closes again mechanically. AC or DC power supply.

INVERTED operation. Power on to close. DC current.

For example: If the lock release is to be connected to a fire alarm system, it must run in inverted operation mode (N-500 operation), i.e. keeping the door open in the event of power failure and remaining closed during the time it is powered up. Under other circumstances, a lock that works as normal is needed, in N operation (Vac), or N-400 operation (Vdc), so that when the power is on, it releases the door. This performance is achieved in both AC (Vac) and DC (Vdc) systems.

(For more information, see the "Operating types" section on page 4).

2. Quick guide

FLUSH LOCK RELEASE

<p>450 SERIES</p>  <p>UNIVERSAL Symmetrical Medium body 12Vac or 12Vdc Allows MAX</p> <p>page 16</p>	<p>UNIVERSAL</p>  <p>UNIVERSAL Non-symmetrical Large body 12Vac or 24Vdc Allows MAX</p> <p>page 17</p>	<p>410 SERIES</p>  <p>REPLACEMENT Symmetrical. Small body. 12Vac or 12Vdc. European profile: 16mm MAX as standard</p> <p>page 18</p>	<p>3000 SERIES</p>  <p>ACCESS CONTROL With door sensor Non-symmetrical Large body 12Vac/12Vdc/24Vdc</p> <p>page 19</p>	<p>500 SERIES</p>  <p>REINFORCED 800KG Symmetrical Medium body 12Vac or 12Vdc</p> <p>page 20</p>	<p>620 SERIES</p>  <p>IP65 WATERTIGHT Non-symmetrical Large body 12Vac</p> <p>page 21</p>	<p>520 SERIES</p>  <p>FIREPROOF Fire resistant Symmetrical Medium body 12Vac or 12Vdc</p> <p>page 22</p>
<p>460 SERIES</p>  <p>AMERICA Protected bolt Symmetrical Body 75mm 12Vac o 12Vdc</p> <p>page 23</p>	<p>470 SERIES</p>  <p>AMERICA Protected bolt Symmetrical Body 85 mm 12Vac o 12Vdc</p> <p>page 24</p>	<p>9000 SERIES</p>  <p>AMERICA Protected bolt Non-Symmetrical Body 102 mm 12Vac o 12Vdc</p> <p>page 25</p>	<p>850 SERIES</p>  <p>CERRADURA AUTOM. Automatic operation 12Vac o 12Vdc</p> <p>page 26</p>	<p>CII SERIES</p>  <p>CRYSTAL 1 leaf Non-Symmetrical Body 105 mm 12Vac o 12Vdc</p> <p>page 27</p>	<p>ELECTROMAG.</p>  <p>ELECTROMAGNETIC Body 233 mm 12Vdc o 24Vdc Resistance 300kg</p> <p>page 28</p>	

SURFACE LOCK RELEASE

<p>2001 SERIES</p>  <p>UNIVERSAL Visible support Non-symmetrical 12Vac Allows MAX</p> <p>page 29</p>	<p>2005 SERIES</p>  <p>UNIVERSAL Hidden support Non-symmetrical 12Vac Allows MAX</p> <p>page 30</p>	<p>2003 SERIES</p>  <p>UNIVERSAL Hidden support Non-symmetrical 12Vac Allows MAX</p> <p>page 31</p>	<p>NGB SERIES</p>  <p>INGERSOLL For INGERSOLL SC71 type locks 12Vac o 12Vdc</p> <p>page 32</p>	<p>6000 SERIES</p>  <p>WITH LATCH/BOLT Hidden support. Deadbolt lock Non-symmetrical 12Vac o 12Vdc</p> <p>page 33</p>	<p>480 SERIES</p>  <p>H LOCK Horizontal locks 12Vac o 12Vdc</p> <p>page 34</p>	<p>490 SERIES</p>  <p>V LOCK Vertical locks 12Vac o 12Vdc</p> <p>page 35</p>
<p>P SERIES</p>  <p>ANTIPANIC Doors with panic bars. Body 140mm 12Vac / 12Vdc 24Vdc</p> <p>page 36</p>	<p>930 SERIES</p>  <p>ELECTRIC Cylinder 50mm. Body 116mm 12Vac / 12 Vdc</p> <p>page 37</p>	<p>960 SERIES</p>  <p>ELECTRIC. REPLACEMENT Adjustable cylinder from 50mm to 70mm Body 140,5mm 12Vac / 12Vdc</p> <p>page 38</p>	<p>8000 SERIES</p>  <p>WITH CHAIN Doors with handle Body 122mm 12Vac</p> <p>page 39</p>	<p>C SERIES</p>  <p>CRYSTAL 2 leaves, one fixed 12Vac</p> <p>page 40</p>	<p>ELECTROMAG.</p>  <p>ELECTROMAGNETIC Body 220mm 12Vdc or 24Vdc Resistance 300kg</p> <p>page 41</p>	<p>ELECTROMAG.</p>  <p>ELECTROMAGNETIC Body 248mm 12Vdc or 24Vdc Resistance 500kg</p> <p>page 41</p>

1. Composition

Each series consists of different references or models depending on the electrical or operating features required. The terminology used in each trade reference follows the same composition.

REF. 30598 LOCK RELEASE **MOD.450** **ND-412** - **S** **MAX**

Model Operation Shield or case Adjustable latch bolt

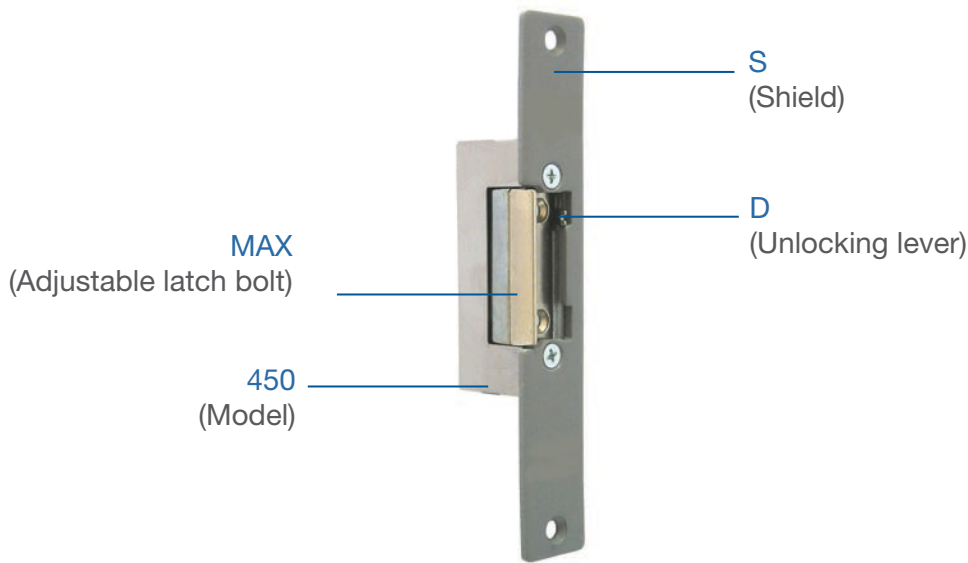



EXAMPLE

FEATURES

	EXAMPLE	FEATURES
MODEL	450, 410, 480, etc.	Identifies the lock or mechanism size and characteristics. If no model is specified, understood as Universal Model (non-symmetrical).
OPERATION	N, ND, A, AD, Aa, AaD N-400, N-500, MAX	Lock release mechanism operation is identified by a letter or letter-number.
SHIELD AND CASE	S, P, G, GE, L, 1001, 1002, 53, F-2006 F-2007, F-2003.	Shield or case type is identified by a number or letter.
MAX mention Adjustable latch	MAX	Identifies lock release with adjustable latch/bolt. To order it, please add an 8 to the end of the trade Ref. of the compatible door lock release.

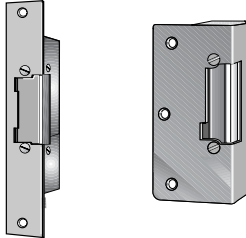
2. Glossary of terms

<p>Reversible Opening enabled both to right and left.</p>  <p>Lock Release Symmetrical Reversible Allows to change sides without changing the frame gap.</p> <p>Lock Release Non-Symmetrical Reversible When changing from left to right the lock does not stay in synch with gap.</p>	 <p>Lock Release for Access Doors Lock Release Non-Symmetrical Reversible</p>	 <p>Lock release with deadbolt lock</p>
--	--	---

Radial latch: The radial system has a built-in bolt that rotates on a displaced axis, limiting the bolts movement perimeter. Lock release installation is easier and looks better as no lateral cuts are made to the door frame.

N	Normal Operation: 12Vac.
N-412	Normal Operation: 12Vdc.
N-424	Normal Operation: 24Vdc.
A	Automatic Operation: 12Vac.
Aa	Invisible Automatic Operation: 12Vac. The automatic pin is suppressed to allow an easier fit to the mechanical lock. A very short electrical pulse is recommended.
A-412	Automatic Operation: 12Vdc.
N-512	Inverted Operation: 12Vdc.
N-524	Inverted Operation: 24Vdc.
D	With unlocking tab.
MAX	With adjustable latch.

SHIELD TYPE

S, SX*	Short shield: 25 x 160.
P, PX*	Short shield: 25 x 130.
P22	Short shield: 22 x 130.
B22	Short shield: 22 x 110.
G, GX*	Long shield with 36 mm standard distance between latch and bolt.
M, MX*	Long shield with 16 mm distance between latch and bolt and 17 x 91 deadbolt lock.
L	Long shield with 16 mm distance between latch and bolt and 13 x 91 deadbolt lock.
T	Long shield with 16 mm distance between latch and bolt and 85 mm high deadbolt lock.
GE	Long shield with very short distance (12 mm) between latch and bolt and 60 mm high deadbolt lock
53	Angular short shield: 25 x 160.
1001	Angular long shield with deadbolt lock (left DIN 1001).
1002	Angular long shield with deadbolt lock (right DIN 1002).

* Stainless steel shield.

CASE TYPE

2001	One-piece case in polished chrome. Visible attachment on frame.
2006	One-piece case in matt grey. Visible attachment on frame.
2003	Two-piece case in anodized aluminium. Hidden frame attachment.
2005	One-piece case in polished chrome. Hidden frame attachment.
2007	One-piece case in matt grey. Hidden frame attachment.

450 SERIES 	Current	Type	Short shield S	Large shield M
	12 Vac	N		3071
ND			2834	2832
A			3069	2822
AD			2820	2818
Aa			2815	
AaD			2821	
12 Vdc	N-412		3070	2824
	ND-412		3059	2830
	A-412		3057	2814
	AD-412		3058	2816
	Aa-412		2817	
	AaD-412		2819	
		N-512	2828	2826

* To order the MAX version lock release with adjustable latch bolt, please add 8 to the end of the reference.

UNIVERSAL SERIES 	Current	Type	Short shield S	Large shield G
	12 Vac	N		2911
ND			2912	2925
A			2909	2926
AD			2910	2927
12 Vdc	N-412		2958	3039
	A-412		3038	
	AD-412		3093	
	N-512		2967	
24 Vdc	N-424		2962	
	A-424		2908	
	AD-424		2907	
	N-524		2968	

* To order the MAX version lock release with adjustable latch bolt, please add 8 to the end of the reference.

410 SERIES 	Current	Type	Short shield P22	Large shield L22
	12 Vac	N		3040
ND			3041	2803
A			3048	2804
AD			3068	2805
12 Vdc	N-412		2889	2809
	ND-412		2806	2810
	A-412		2890	2811
	AD-412		2807	2812
		N-512	2808	2813

3000 SERIES 	Current	Type	Short shield S
	12 Vac	N	
12 Vdc	N-412		29580
	N-512		29670
24 Vdc	N-424		29620
	N-524		29680

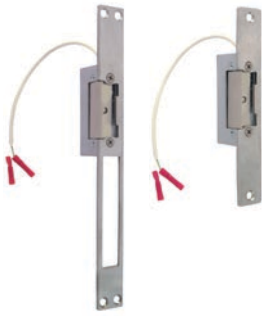
500 SERIES		Current	Type	Short shield SX	Large shield MX
	12 Vac	N	2880	2884	
		ND	2881	2885	
		A	2882	2886	
		AD	2883	2887	
	12 Vdc	N-412	2888	3109	
		ND-412	3105	2796	
		A-412	3106	2797	
		AD-412	3107	2798	
		N-512	3108	2799	

620 SERIES		Current	Type	Short shield SX	Large shield GX
	12 Vac	N	2874	2876	
		Aa	2875	2877	

520 SERIES		Current	Type	Short shield PX
	12 Vac	N	2870	
		A	2871	
	12 Vdc	N-412	2872	
		N-512	2873	

AMERICA SERIES		Current	Type	460	470	9000
	12 Vac	N	2956	3027	2969	
		Aa			2971	
	12 Vdc	N-412	3061	3028	3063	
		N-512	3062	3029		

460 470 9000

850 SERIES		Current	Distance* (mm)	850 Series
	12 Vac 12 Vdc	25	3102	
		30	3104	
		35	3103	
		50	3101	

* mm distance between cylinder centre and front.

CRYSTAL SERIES		Current	Type	Single leaf CII-SX	Double leaf C
	12 Vac		N	3095	2996
			ND		2997
			A	3094	2961
			AD		2998
	12 Vdc		N-412	3096	
			N-512	3098	

CII

C

ELECTROMAGNETIC		Current	Type	300 kg	500 kg
	12 Vdc 24 Vdc		FLUSH	3050	
			SURFACE	3052	3051

3050

3051

3052

2000 SERIES		Current	Type	Visible attachment on frame		Hidden frame attachment		
				2001	2006	2005	2007	2003
	12 Vac		N	2923	3000	2948	2952	2940
			A	2917	3002	2950	2954	2942



2001-2006

2005-2007



2003

NGB SERIES		Current	Type	INGERSOLL SC71	
	12 Vac		N	2989	
			12 Vdc	N-412	3074
				N-512	3075

6000 SERIES		Current	Type	Locking door
	12 Vac	N	3004	
		A	3005	
		AD	3006	
	12 Vdc	N-412	3072	
		N-512	3073	

480 SERIES - 490 SERIES		Current	Type	Locking door 480 SERIES (H)	Locking door 490 SERIES (V)
  H V	12 Vac	N	3030	3034	
		Aa	3031	3035	
	12 Vdc	N-412	3032	3036	
		N-512	3033	3037	

PANIC SERIES		Current	Type	P
	12 Vac	N	3064	
	12 Vdc	N-412	3065	
		N-512	3066	
	24 Vdc	N-424	3067	

ELECTRIC LOCKS		Current	Type	930	960
 930	12 Vac/ 12Vdc	DOUBLE KEY	3007	2878	
		DOUBLE KEY + PUSHBUTTON	2991	2879	
		DOUBLE KEY - NO PUSHBUTTON FUNCTION	3042		
 960					

8000 SERIES		Current	Type	With chain
	12 Vac	N	2984	





LOCK RELEASE TYPES

FERMAX

FLUSH-MOUNTED
SURFACE



Universal 450 Series. Symmetrical

TECHNICAL FEATURES

- Body 75 mm.
 - Front panel 21 mm.
 - Reversible (Right DIN or Left DIN).
 - Symmetrical.
 - Includes S-type shield for access doors or M-type shield for locking doors. Other compatible shields: short (P, P22, B22, 53) and long (T, L, L22, 1001 and 1002).
 - **Allows MAX version:** All models can be ordered with adjustable bolt by adding 8 to the end of the reference.
- Flush-mounted in wooden or metal frames. Small size allows change of hand without having to enlarge the space where the lock release is inserted.

SPECIFICATIONS

Consumption:

N, A, Aa	12Vac:	980mA
N-412	12Vdc:	400mA
N-512	12Vdc:	200mA

Temperature: -40 to 120°C

Resistance (Kg): 230

Tested cycles: 200.000

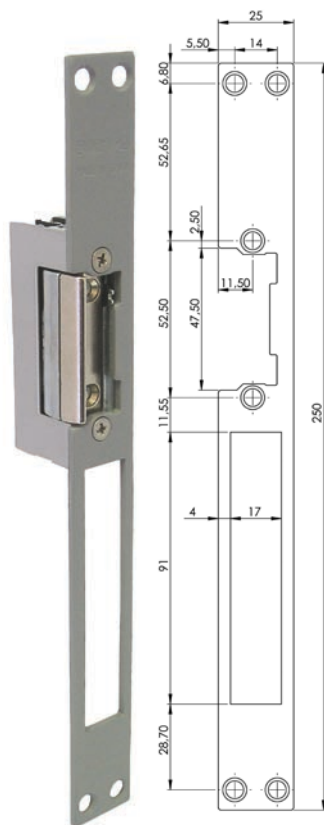

450ND-M MAX M

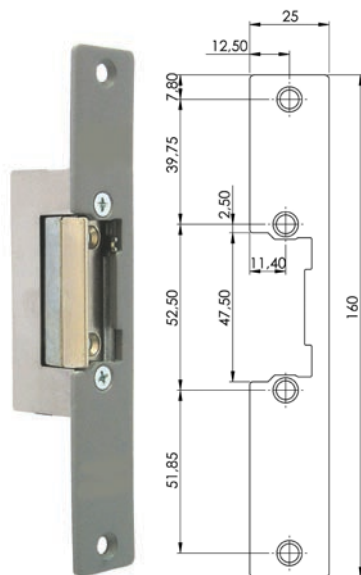

450ND-S MAX S

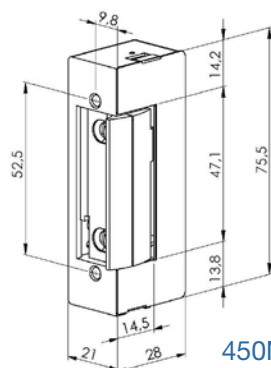

450ND-MAX

REFERENCES

12 Vac

For access doors (S shield)

- 3071 UNIVERSAL LOCK RELEASE MOD.450N-S
- 2834 UNIVERSAL LOCK RELEASE MOD.450ND-S
- 3069 UNIVERSAL LOCK RELEASE MOD.450A-S
- 2820 UNIVERSAL LOCK RELEASE MOD.450AD-S
- 2815 UNIVERSAL LOCK RELEASE MOD.450Aa-S
- 2821 UNIVERSAL LOCK RELEASE MOD.450AaD-S

For security doors (M shield)

- 2836 UNIVERSAL LOCK RELEASE MOD.450N-M
- 2832 UNIVERSAL LOCK RELEASE MOD.450ND-M
- 2822 UNIVERSAL LOCK RELEASE MOD.450A-M
- 2818 UNIVERSAL LOCK RELEASE MOD.450AD-M

12 Vdc

For access doors (S shield)

- 3070 UNIVERSAL LOCK RELEASE MOD.450N-412-S
- 3059 UNIVERSAL LOCK RELEASE MOD.450ND-412-S
- 3057 UNIVERSAL LOCK RELEASE MOD.450A-412-S
- 3058 UNIVERSAL LOCK RELEASE MOD.450AD-412-S
- 2817 UNIVERSAL LOCK RELEASE MOD.450Aa-412-S
- 2819 UNIVERSAL LOCK RELEASE MOD.450AaD-412-S
- 2828 UNIVERSAL LOCK RELEASE MOD.450N-512-S

For locking doors (M shield)

- 2824 UNIVERSAL LOCK RELEASE MOD.450N-412-M
- 2830 UNIVERSAL LOCK RELEASE MOD.450ND-412-M
- 2814 UNIVERSAL LOCK RELEASE MOD.450A-412-M
- 2816 UNIVERSAL LOCK RELEASE MOD.450AD-412-M
- 2826 UNIVERSAL LOCK RELEASE MOD.450N-512-M

Universal Series. Non-Symmetrical

CARACTERÍSTICAS TÉCNICAS

- Body 104 mm.
- In MAX version, the body is 90 mm.
- Front panel 20 mm.
- Reversible (Right DIN or Left DIN).
- Non-symmetrical.
- Includes S-type shield for access doors and G-type shield for locking doors.
Other compatible shields: P, M, L, 1001, 1002, 53.
- **Allows MAX version:** All models can be ordered with adjustable bolt by adding 8 to the end of the reference.

SPECIFICATIONS

Consumption:
 N, A 12Vac: 980mA
 N-412 12Vdc: 200mA
 N-512 12Vdc: 150mA
 N-424 24Vdc: 120mA

Temperature: -40 to 120°C
Resistance (Kg): 260
Tested cycles: 200.000

Flush mounting in wooden or metal frames. Characteristic robust design and low power consumption.

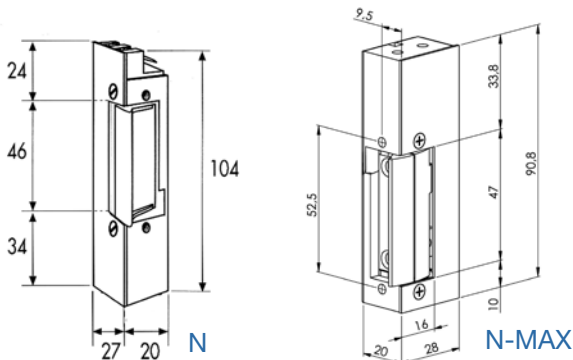
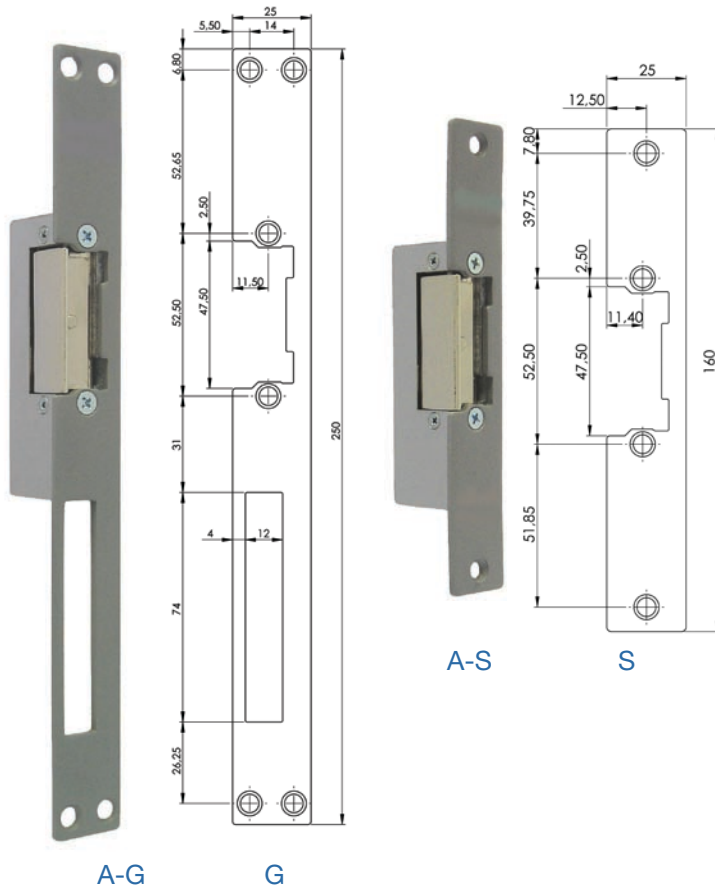

REFERENCES

12 Vac

For access doors (S shield)

- 2911 UNIVERSAL LOCK RELEASE N-S
- 2912 UNIVERSAL LOCK RELEASE ND-S
- 2909 UNIVERSAL LOCK RELEASE A-S
- 2910 UNIVERSAL LOCK RELEASE AD-S

For security doors (G shield)

- 2924 UNIVERSAL LOCK RELEASE N-G
- 2925 UNIVERSAL LOCK RELEASE ND-G
- 2926 UNIVERSAL LOCK RELEASE A-G
- 2927 UNIVERSAL LOCK RELEASE AD-G

12 Vdc

For access doors (S shield)

- 2958 UNIVERSAL LOCK RELEASE N-412-S
- 3038 UNIVERSAL LOCK RELEASE A-412-S
- 3093 UNIVERSAL LOCK RELEASE AD-412-S
- 2967 UNIVERSAL LOCK RELEASE N-512-S

For security doors (G shield)

- 3039 UNIVERSAL LOCK RELEASE N-412-G

24 Vdc

For access doors (S shield)

- 2962 UNIVERSAL LOCK RELEASE N-424-S
- 2908 UNIVERSAL LOCK RELEASE A-424-S
- 2907 UNIVERSAL LOCK RELEASE AD-424-S
- 2968 UNIVERSAL LOCK RELEASE N-524-S

Replacement 410 Series. European Profile

TECHNICAL FEATURES

- Body 67 mm.
- Front panel 16,5mm.
- Reversible (Right DIN or Left DIN).
- Symmetrical.
- Radial latch.
- Includes P22-type shield for access doors and L22-type shield for locking doors.
Other compatible shields: B22, M, T, GE.
- Adjustable latch bolt. **MAX Version** as standard

SPECIFICATIONS

Consumption:
 N, A 12Vac: 980mA
 N-412 12Vdc: 400mA
 N-512 12Vdc: 200mA

Temperature: -40 to 120°C
Resistance (Kg): 300
Tested cycles: 200.000

Recommended for replacement.

The smallest door lock release on the market (front width 16,5 mm). Installed in smaller aluminium or PVC frames.

Includes radial latch allowing the bolt to rotate on its axis without having to make a lateral cut in the door frame, which is not possible in traditional latch-bolt locks.

The standard version offers MAX adjustable latch, allowing the adjustment between the latch and the bolt in the installation process.

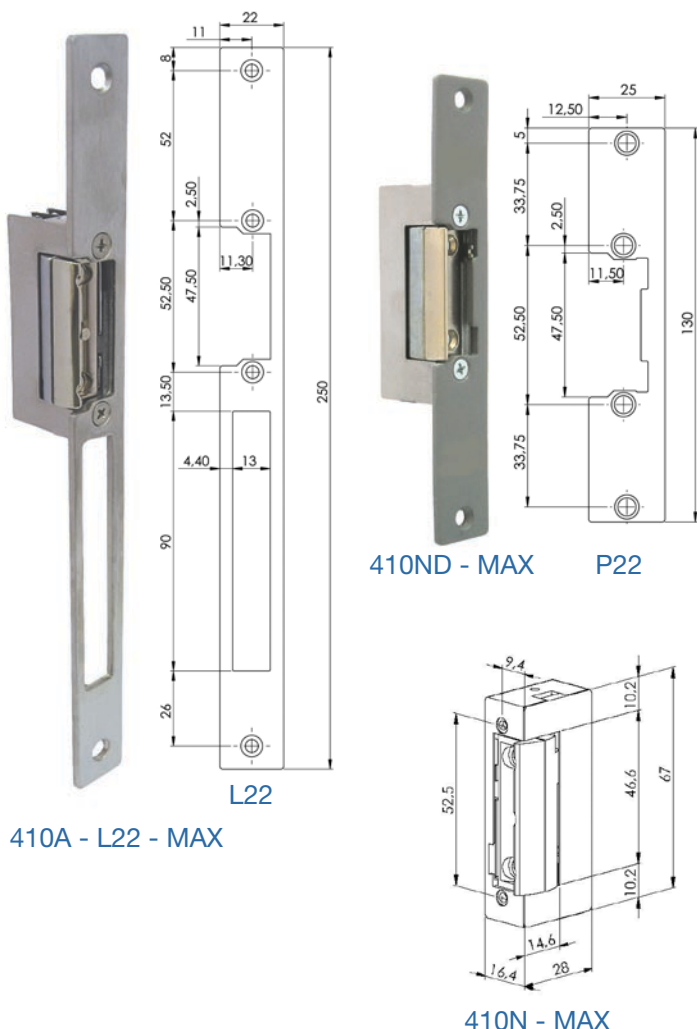

REFERENCES

12 Vac

For access doors (P22 shield)

- 3040 LOCK RELEASE MOD.410N-P22-MAX
- 3041 LOCK RELEASE MOD.410ND-P22-MAX
- 3048 LOCK RELEASE MOD.410A-P22-MAX
- 3068 LOCK RELEASE MOD.410AD-P22-MAX

For locking doors (L22 shield)

- 2802 LOCK RELEASE MOD.410N-L22-MAX
- 2803 LOCK RELEASE MOD.410ND-L22-MAX
- 2804 LOCK RELEASE MOD.410A-L22-MAX
- 2805 LOCK RELEASE MOD.410AD-L22-MAX

12 Vdc

For access doors (P22 shield)

- 2889 LOCK RELEASE MOD.410N-412-P22-MAX
- 2806 LOCK RELEASE MOD.410ND-412-P22-MAX
- 2890 LOCK RELEASE MOD.410A-412-P22-MAX
- 2807 LOCK RELEASE MOD.410AD-412-P22-MAX
- 2808 LOCK RELEASE MOD.410N-512-P22-MAX

For locking doors (L22 shield)

- 2809 LOCK RELEASE MOD.410N-412-L22-MAX
- 2810 LOCK RELEASE MOD.410ND-412-L22-MAX
- 2811 LOCK RELEASE MOD.410A-412-L22-MAX
- 2812 LOCK RELEASE MOD.410AD-412-L22-MAX
- 2813 LOCK RELEASE MOD.410N-512-L22-MAX

3000 Series. With door sensor

TECHNICAL FEATURES

- Body 104 mm.
- Front panel 20 mm.
- Reversible (Right DIN and Left DIN).
- Non-symmetrical.
- Includes S type shield for access doors.
Other compatible shields: P, 53, G, M, L, 1001, 1002, 53.
- Includes microswitch (C, NO, NC). For signals and other applications.

This version allows a range of applications due to its highly reliable C/No/Nc microswitch with gold contacts. Maximum contact intensity is 2A-230Vac. Indicates if the door is open or closed. Indispensable in security and alarm installations in banks, laboratories, jewellery stores and all premises that require door opening with automatic locking of another and vice versa.

See sample installation in *INSTALLATION DIAGRAMS* page 61.

SPECIFICATIONS

Consumption:

N	12Vac:	980mA
N-412, N-512	12Vdc:	150mA
N-424, N-524	24Vdc:	120mA

Temperature: -40 to 120°C

Resistance (Kg): 260

Tested cycles: 200.000

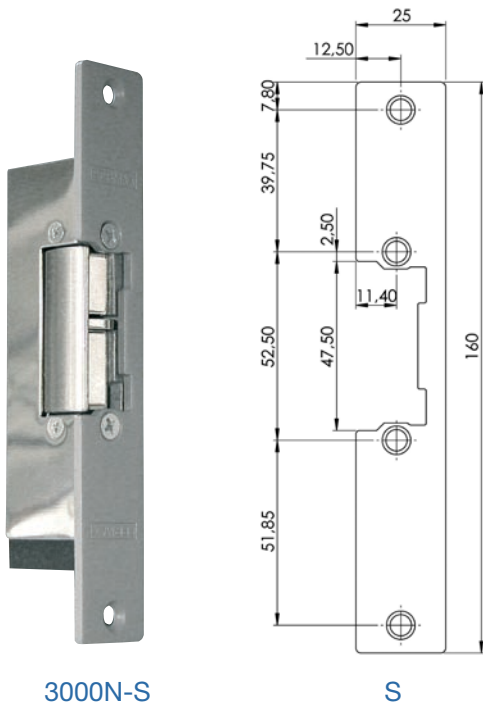

3000N-S

S

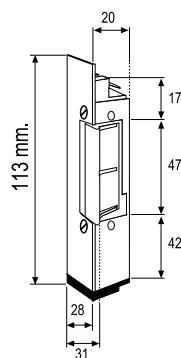
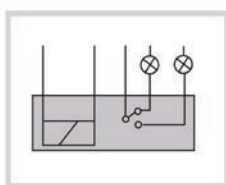

3000N

REFERENCES

- 2953 LOCK RELEASE MOD.3000N-S
- 29580 LOCK RELEASE MOD.3000N-412-S
- 29670 LOCK RELEASE MOD.3000N-512-S
- 29620 LOCK RELEASE MOD.3000N-424-S
- 29680 LOCK RELEASE MOD.3000N-524-S

500 Series Reinforced (800 Kg)

TECHNICAL FEATURES

As 450 series but with reinforced steel latch.

- Body 75 mm.
- Front panel 21 mm.
- Reversible (Right DIN or Left DIN).
- Symmetrical.
- With steel bolt impact resistant up to 800 kg.
- Includes SX-type shield for access doors and MX shield for locking doors. Other compatible shields: P, P22, B22, 53, T, L, L22, 1001, 1002.

Recommended for heavy doors in frequent use. Doors in wrought iron, iron or steel with heavy traffic in access. Includes a wire conduit for easy installation with a simple splice connector.

SPECIFICATIONS

Consumption:
 N, A 12Vac: 980mA
 N-412 12Vdc: 400mA

Temperature: -40 to 120°C
Resistance (Kg): 800
Tested cycles: 200.000

LOCK RELEASE TYPES / FLUSH-MOUNTED

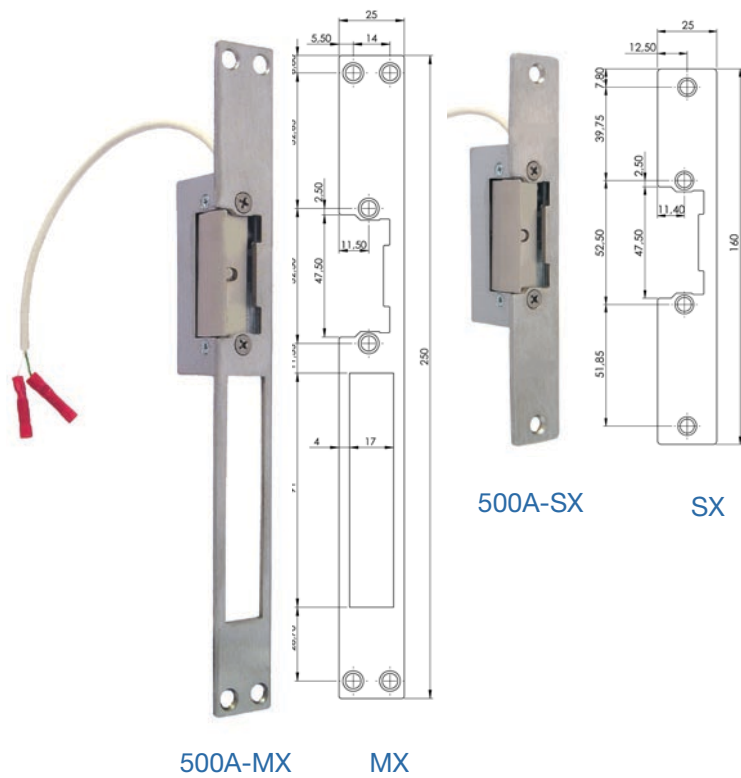

REFERENCES

12 Vac

For access doors (SX shield)

- 2880 LOCK RELEASE MOD.500N-SX
- 2881 LOCK RELEASE MOD.500ND-SX
- 2882 LOCK RELEASE MOD.500A-SX
- 2883 LOCK RELEASE MOD.500AD-SX

For locking doors (MX shield)

- 2884 LOCK RELEASE MOD.500N-MX
- 2885 LOCK RELEASE MOD.500ND-MX
- 2886 LOCK RELEASE MOD.500A-MX
- 2887 LOCK RELEASE MOD.500AD-MX

12 Vdc

For access doors (SX shield)

- 2888 LOCK RELEASE MOD.500N-412-SX
- 3105 LOCK RELEASE MOD.500ND-412-SX
- 3106 LOCK RELEASE MOD.500A-412-SX
- 3107 LOCK RELEASE MOD.500AD-412-SX
- 3108 LOCK RELEASE MOD.500N-512-SX

For locking doors (MX shield)

- 3109 LOCK RELEASE MOD.500N-412-MX
- 2796 LOCK RELEASE MOD.500ND-412-MX
- 2797 LOCK RELEASE MOD.500A-412-MX
- 2798 LOCK RELEASE MOD.500AD-412-MX
- 2799 LOCK RELEASE MOD.500N-512-MX

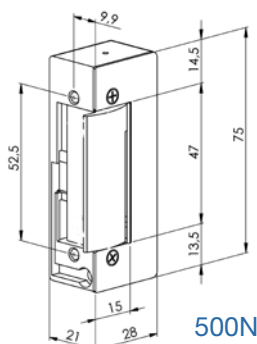

Serie 620 Watertight (IP65)

TECHNICAL FEATURES

- Body de 100 mm.
- Frontal de 21,5 mm.
- Reversible (DIN Derecha o DIN Izquierda).
- Non symmetrical.
- Includes stainless steel SX-type shield for access doors and GX shield for locking doors. Other compatible shields: 53, 1001, 1002.

Recommended for doors in outdoor locations (enclosures, gates, front line beach properties, etc.). It has fewer holes and incorporates internal and external seals to prevent water and dust getting in, prolonging the lock's working life.

SPECIFICATIONS

Consumption:
 N, Aa 12Vac: 980mA
 N-412 12Vdc: 1,3A

Temperature: -40 to 120°C
 Resistance (Kg): 400
 Tested cycles: 200.000

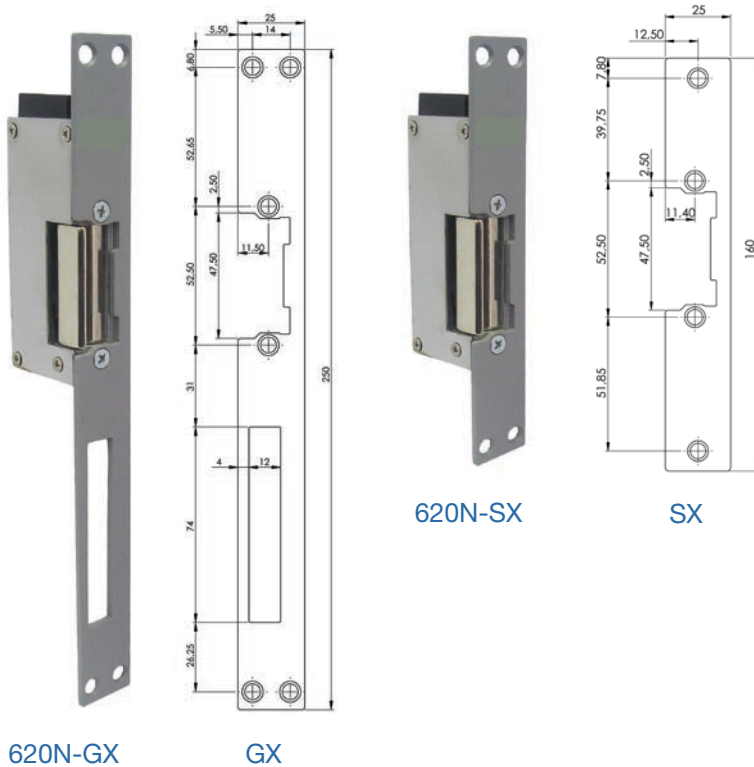

620N-GX

GX

620N-SX

SX

REFERENCES

12 Vac

For access doors (SX shield)

2874 LOCK RELEASE MOD.620N-SX

2875 LOCK RELEASE MOD.620Aa-SX

For locking doors (GX shield)

2876 LOCK RELEASE MOD.620N-GX

2877 LOCK RELEASE MOD.620Aa-GX

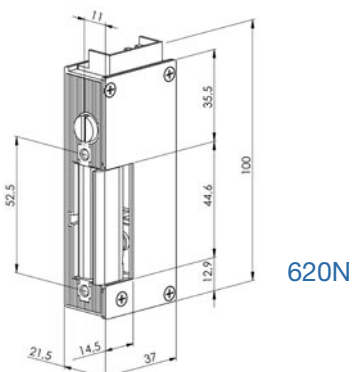

620N

520 Series Fireproof

TECHNICAL FEATURES

- Body 75,4 mm.
- Front panel 21 mm.
- Reversible (Right DIN or Left DIN).
- Symmetrical.
- Radial latch.
- Includes PX-type stainless steel casing for access doors. For locking door, with latch recess, MX-type shield recommended.

Recommended for Fire Doors or firewalls.

SPECIFICATIONS

Consumption:

N, A 12Vac: 980mA
N-412 12Vdc: 1,3A

Temperature: -40 to 120°C

Resistance (Kg): 800
Tested cycles: 200.000

LOCK RELEASE TYPES / FLUSH-MOUNTED

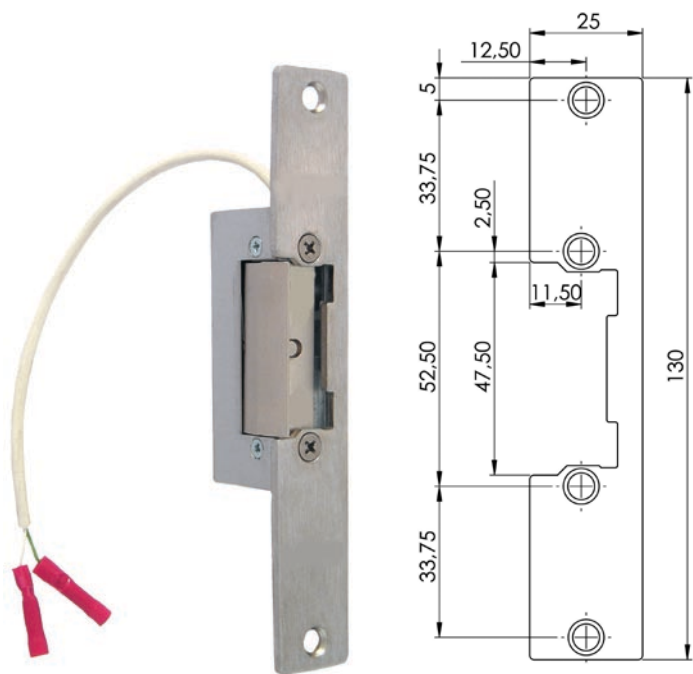

520A-PX

PX

REFERENCES

12 Vac

For access doors (PX shield)

2870 LOCK RELEASE MOD.520N-PX

2871 LOCK RELEASE MOD.520A-PX

12 Vdc

For access doors (PX shield)

2872 LOCK RELEASE MOD.520N-412-PX

2873 LOCK RELEASE MOD.520N-512-PX

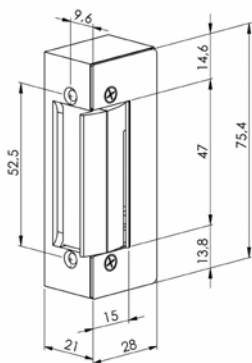

520N

460 Series

TECHNICAL FEATURES

- Body 75,3 mm.
- Reversible (Right DIN or Left DIN).
- Symmetrical.

The deeper latch and shield make it particularly suitable for metal frames. Also suitable for American or British locks.

SPECIFICATIONS

Consumption:

N	12Vac:	980mA
N-412	12Vdc:	400mA
N-512	12Vdc:	200mA

Temperature: -40 to 120°C

Resistance (Kg): 210

Tested cycles: 200.000



460N

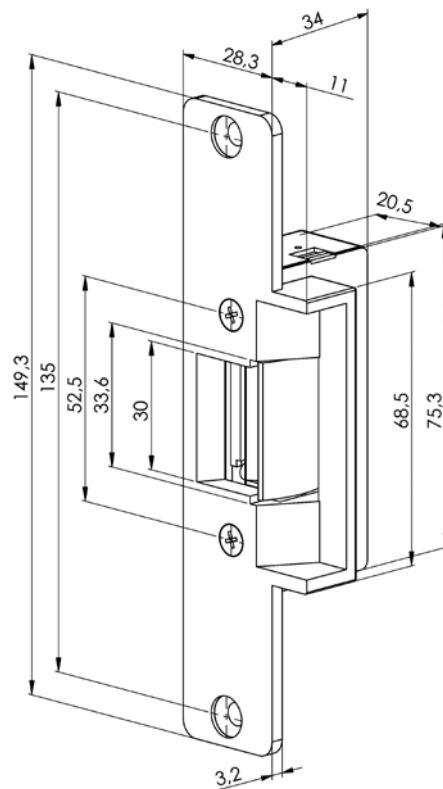

460N

REFERENCES

- 2956 LOCK RELEASE MOD.460N BISEL
- 3061 LOCK RELEASE MOD.460N-412
- 3062 LOCK RELEASE MOD.460N-512

470 Series

TECHNICAL FEATURES

- Body 85 mm.
- Reversible (Right DIN or Left DIN).
- Symmetrical.

As 460 series but with an even deeper and longer latch. Designed to protect and conceal the latch recess.

SPECIFICATIONS

Consumption:	
N	12Vac: 980mA
N-412	12Vdc: 400mA
N-512	12Vdc: 200mA

Temperature: -40 to 120°C
 Resistance (Kg): 230
 Tested cycles: 200.000

LOCK RELEASE TYPES / FLUSH-MOUNTED



470N

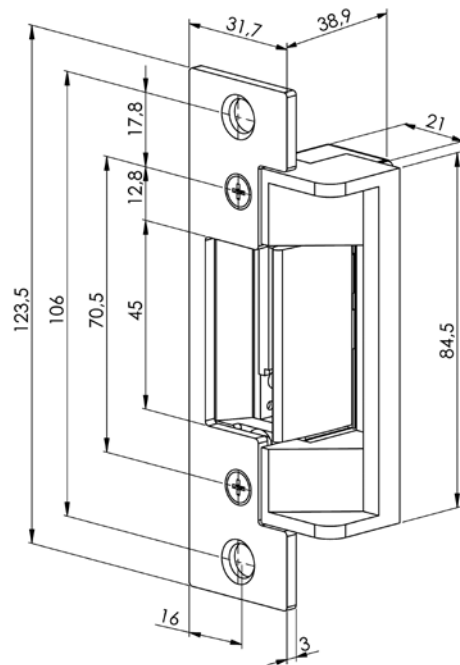

470N

REFERENCES

- 3027 LOCK RELEASE MOD.470N
- 3028 LOCK RELEASE MOD.470N-412
- 3029 LOCK RELEASE MOD.470N-512

9000 Series

TECHNICAL FEATURES

- Body 102 mm.
- Reversible (Right DIN or Left DIN).
- Non-symmetrical.

Recommended for flush mounting in metal frames, for its flanged shield and reinforced latch.

SPECIFICATIONS

Consumption:
 N, Aa 12Vac: 980mA
 N-412 12Vdc: 400mA

Temperature: -40 to 120°C
 Tested cycles: 200.000



9000N

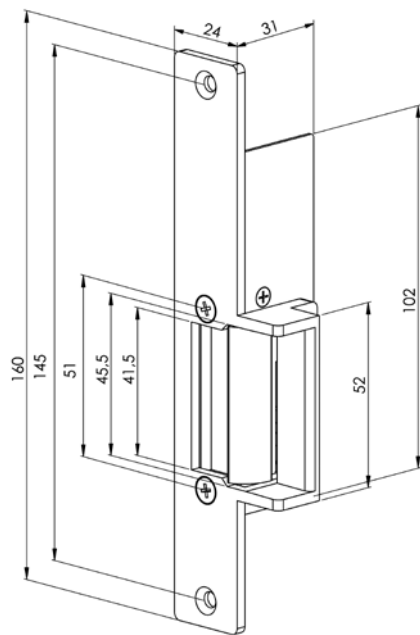

9000N

REFERENCES

- 2969 LOCK RELEASE MOD.9000N GREY
- 2971 LOCK RELEASE MOD.9000Aa GREY
- 3063 LOCK RELEASE MOD.9000N-412 GREY

850 Series Automatic lock

TECHNICAL FEATURES

- The automatic lock consists of 2 parts:
 - Mechanical part (on the door leaf)
 - Electrical part (located in the frame)
- Mechanical body 174 mm and front panel 17 mm.
- Electric body 112 mm and front panel 14,20 mm.
- Reversible (Right DIN or Left DIN).
- Includes stainless steel shield.
- There are several models depending on the distance between the centre of the cylinder and front panel A*.

The bolt is passed automatically with no need for keys.
Opening, also automatic, can be performed remotely.

SPECIFICATIONS

Consumption:	
12Vac:	990mA
12Vdc:	1350mA
Tension:	12V
Temperature:	-10°C to 50°C

TYPES AND DIMENSIONS

TYPES	A*	B*
Mod.850/25	25	39
Mod.850/30	30	44
Mod.850/35	35	49
Mod.850/50	50	64

*A: Distance in mm between centre of cylinder and front part.

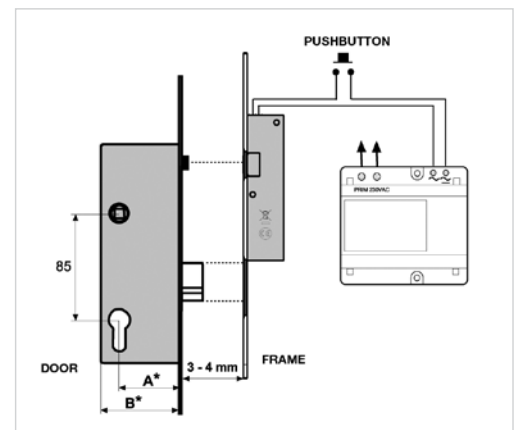
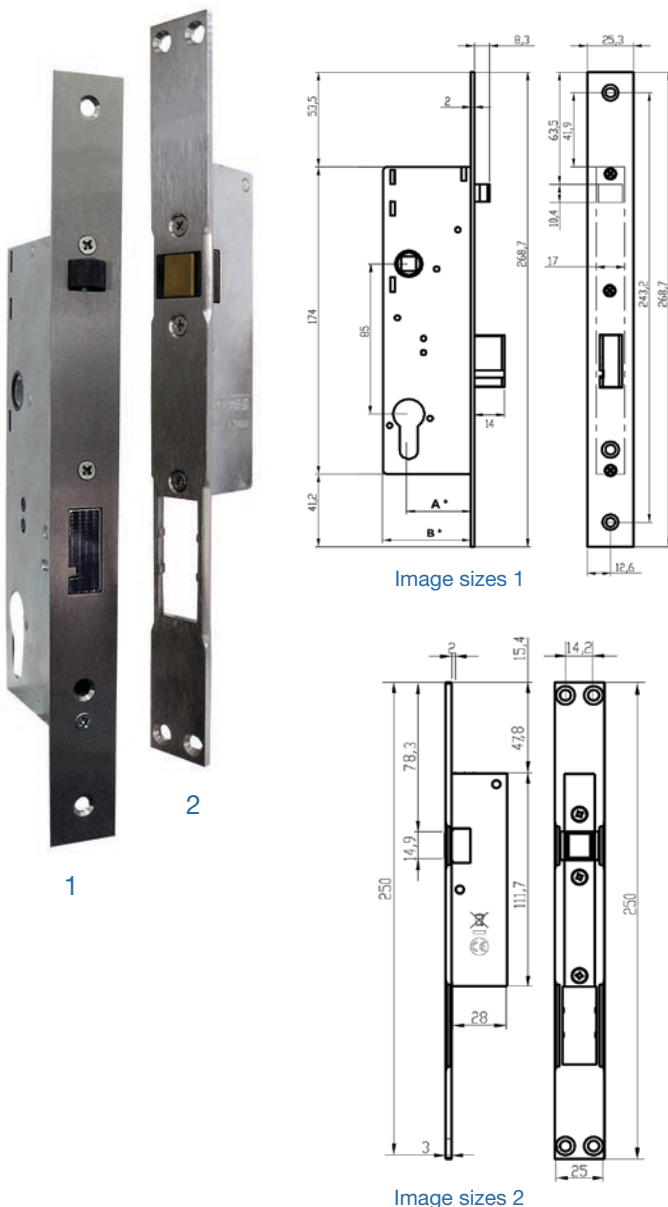

REFERENCES

- 3102 AUTOMATIC LOCK MOD.850/25 A
- 3104 AUTOMATIC LOCK MOD.850/30 A
- 3103 AUTOMATIC LOCK MOD.850/35 A
- 3101 AUTOMATIC LOCK MOD.850/50 A
- 2869 MECHANISM MOD.850 A
Included in all automatic locks for replacement.

CI Crystal Series. Single leaf

TECHNICAL FEATURES

- For single leaf glass doors up to 12 mm.
- Reversible (Right DIN or Left DIN).
- Non-symmetrical
- For double leaf doors, 2 lock releases must be fitted in the upper part of the frame, one for each leaf.
- Includes a safety device to prevent lock release blocking if the door is open.
- Cannot be used for swing doors.

Recommended for glass doors equipped with upper or lateral frame, in metallic or wooden profile.

SPECIFICATIONS

Consumption:

N, A 12Vac: 980mA
 N-412 12Vdc: 200mA
 N-512 12Vdc: 150mA

Temperature: -40 to 120°C

Resistance (Kg): 260
Tested cycles: 200.000

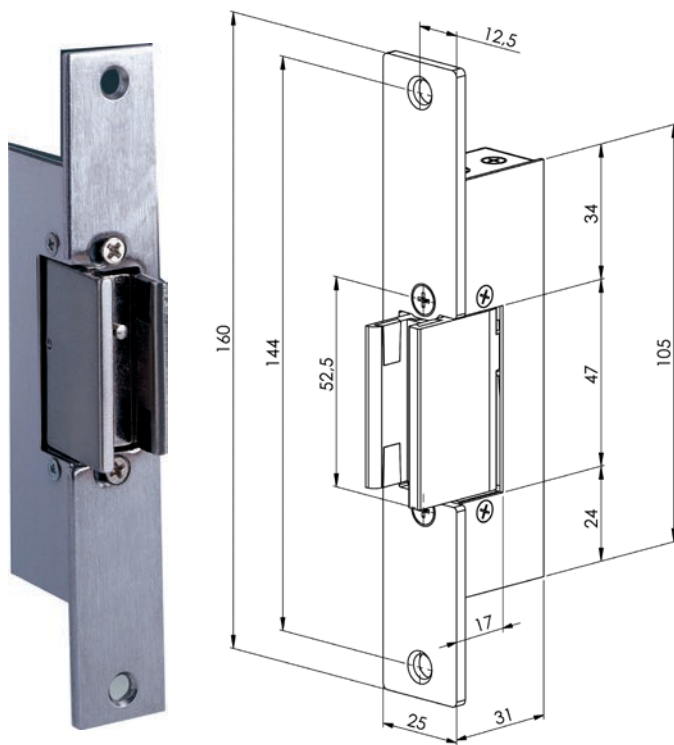

CIIN-SX

CIIN-SX

REFERENCES

- 3095 CRYSTAL LOCK RELEASE MOD.CIIN-SX
- 3094 CRYSTAL LOCK RELEASE MOD.CIIA-SX
- 3096 CRYSTAL LOCK RELEASE MOD.CIIN-412-SX
- 3098 CRYSTAL LOCK RELEASE MOD.CIIN-512-SX



Glass door with wood profile

Electromagnetic Series

TECHNICAL FEATURES:

- Allows to close a door without a traditional lock. Also used to keep doors open for security purposes.
- Inverted operation. The electromagnetic lock releases the door when the power is off.
- Consists of an electromagnet fitted in the frame of the door or access and a metal plate installed in the moving part of the door.
- When the electromagnet is powered up, closing is secured by magnetic pull of the magnet on the plate. When the magnet is not powered, the door is released.
- Suitable for installations where we want to hide the electromagnet and for sliding doors.
- Includes assembly kit and installation instructions.
- Runs on 12 Vdc or 24 Vdc power supply.

See installation instructions supplied with the equipment.

SPECIFICATIONS

Consumption:

12Vdc: 500mA

24Vdc: 250mA

Resistance (kg): 300

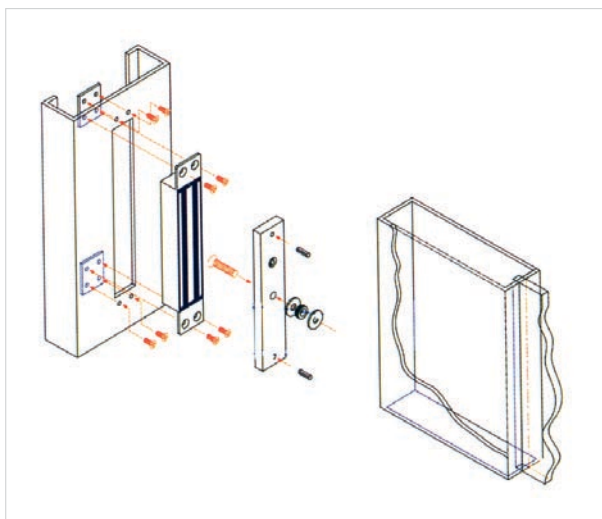
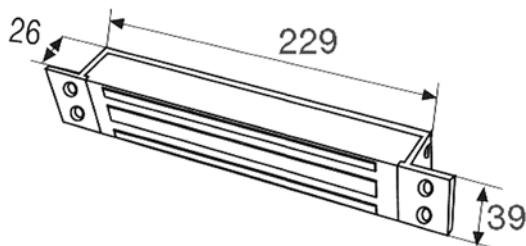

REFERENCES

3050 ELECTROMAGNETIC LOCK RELEASE
FLUSH-MOUNTED 300Kg

Holding force 3000N. For two-way doors.

2001-2006 Series. Visible attachment

TECHNICAL FEATURES:

- Includes Universal mechanism.
- One-piece case 146 mm.
- Reversible (Right DIN or Left DIN).
- Non-symmetrical.
- Visible attachment on frame.
- For locks without latch/bolt.
- **Allows MAX version:** All models can be ordered with adjustable latch/bolt by adding 8 to the end of the reference.

SPECIFICATIONS

Consumption:
N, A 12Vac: 980mA

Temperature: -40 to 120°C
Resistance (Kg): 260
Tested cycles: 200.000



N-2001

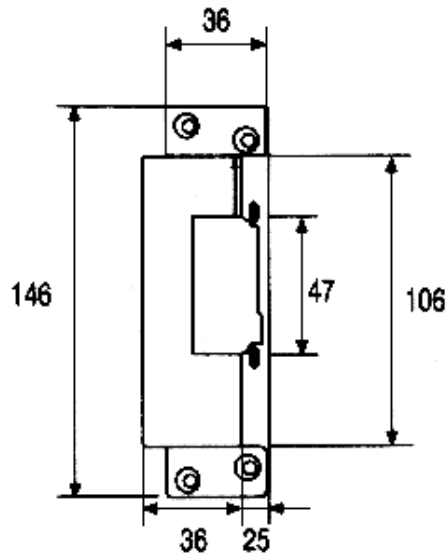

2001

REFERENCES

2001 SERIES Chrome

- 2923 LOCK RELEASE N-2001 CHROME
- 2917 LOCK RELEASE A-2001 CHROME

2006 SERIES Grey

- 3000 LOCK RELEASE N-2006 GREY
- 3002 LOCK RELEASE A-2006 GREY

2005 - 2007 Series. Hidden attachment

TECHNICAL FEATURES

- Includes Universal mechanism.
- One-piece case 106 mm.
- Reversible (Right DIN or Left DIN).
- Non-symmetrical
- Attachment concealed on frame.
- For locks without latch/bolt.
- **Allows MAX version:** All models can be ordered with adjustable latch/bolt by adding 8 to the end of the reference.

SPECIFICATIONS

Consumption:

N, A 12Vac: 980mA

Temperature: -40 to 120°C

Resistance (Kg): 260

Tested cycles: 200.000



N-2005

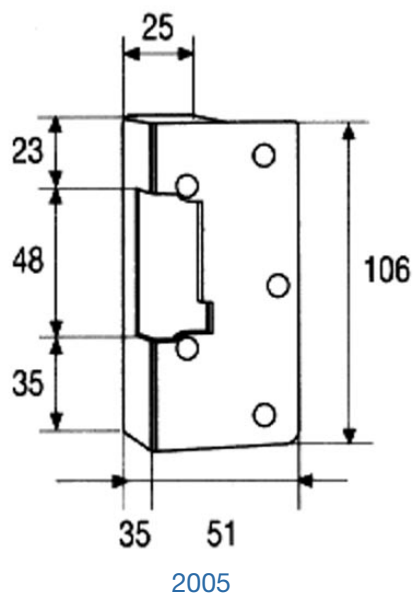

2005

REFERENCES

2005 SERIES Chrome

2948 LOCK RELEASE N-2005 CHROME

2950 LOCK RELEASE A-2005 CHROME

2007 SERIES Grey

2952 LOCK RELEASE N-2007 GREY

2954 LOCK RELEASE A-2007 GREY

2003 Series. Hidden attachment

TECHNICAL FEATURES

- Includes Universal mechanism.
- Two-piece case 103 mm.
- Reversible (Right DIN or Left DIN).
- Non-symmetrical.
- Attachment concealed on frame.
- For locks without latch/bolt.
- **Allows MAX version:** All models can be ordered with adjustable latch/bolt by adding 8 to the end of the reference.

Equipped with angular cover and clamping tab. Allows surface and flush mounting, adding a strike plate/shield to the set.

SPECIFICATIONS

Consumption:
N, A 12Vac: 980mA

Temperature: -40 hasta 120°C
Resistance (Kg): 260
Tested cycles: 200.000



N-2003

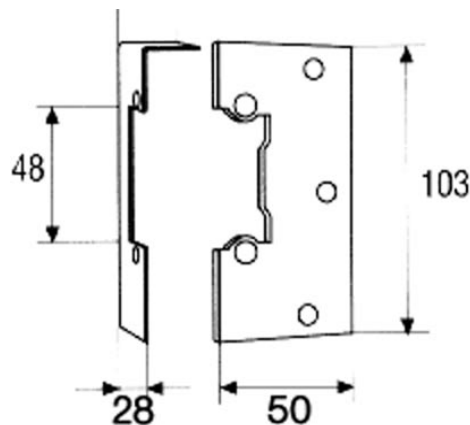

2003

REFERENCES

- 2940 LOCK RELEASE N-2003 AL. ANOD.
- 2942 LOCK RELEASE A-2003 AL. ANOD.

NGB Series

TECHNICAL FEATURES

- For INGERSOLL SC71 type locks.
- One-piece case 107 mm.
- Reversible (Right DIN or Left DIN).
- Non-symmetrical.
- Attachment concealed on frame.

SPECIFICATIONS

Consumption:

NGB	12Vac:	980mA
NGB-412	12Vdc:	150mA
NGB-512	12Vdc:	150mA



NGB

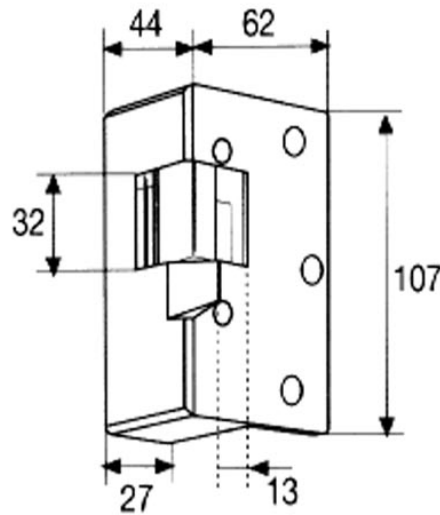

NGB

REFERENCES

- 2989 LOCK RELEASE MOD.NGB
- 3074 LOCK RELEASE MOD.NGB-412
- 3075 LOCK RELEASE MOD.NGB-512



INGERSOLL LOCK

6000 Series

TECHNICAL FEATURES

- For locks with latch/bolt.
- Reversible (Left DIN, Right DIN).
- Symmetrical.
- Attachment concealed on frame.

SPECIFICATIONS

Consumption:		
N, A	12Vac:	980mA
N-412	12Vdc:	200mA
N-512	12Vdc:	150mA



6000A
Left DIN

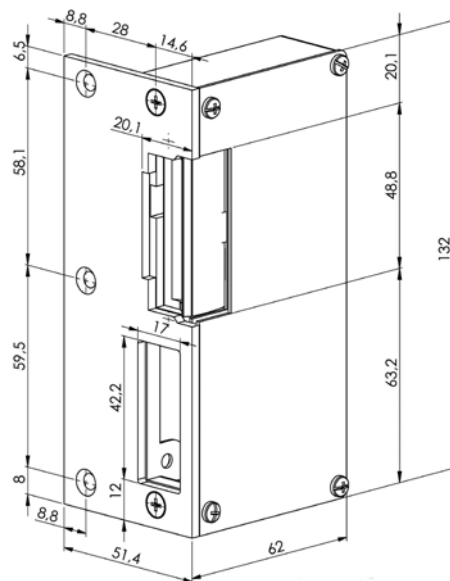

6000A
Left DIN



6000A
Right DIN

REFERENCES

- 3004 LOCK RELEASE MOD.6000N
- 3005 LOCK RELEASE MOD.6000A
- 3006 LOCK RELEASE MOD.6000AD
- 3072 LOCK RELEASE MOD.6000N-412
- 3073 LOCK RELEASE MOD.6000N-512

480 Series. Horizontal

TECHNICAL FEATURES

- For horizontal bolt locks with latch width up to 20mm.
- Body 96 mm.
- Reversible (Right DIN or Left DIN).
- Symmetrical.
- Weather-resistant.
- Attachment concealed on frame.

SPECIFICATIONS

Consumption:

N, Aa	12Vac:	980mA
N-412	12Vdc:	200mA
N-512	12Vdc:	150mA



480N

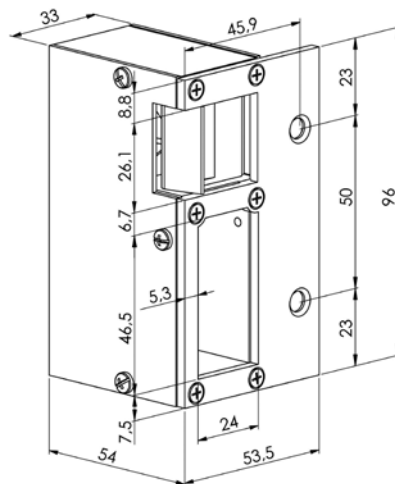

480N

REFERENCES

- 3030 LOCK RELEASE MOD.480N
- 3031 LOCK RELEASE MOD.480Aa
- 3032 LOCK RELEASE MOD.480N-412
- 3033 LOCK RELEASE MOD.480N-512



HORIZONTAL LOCK

490 Series. Vertical

TECHNICAL FEATURES

- For vertical locks with latch/bolt with latch width up to 20.
- Body 122 mm.
- Reversible (Right DIN or Left DIN).
- Symmetrical.
- Weather-resistant.
- Attachment concealed on frame.

SPECIFICATIONS

Consumption:		
N, Aa	12Vac:	980mA
N-412	12Vdc:	200mA
N-512	12Vdc:	150mA

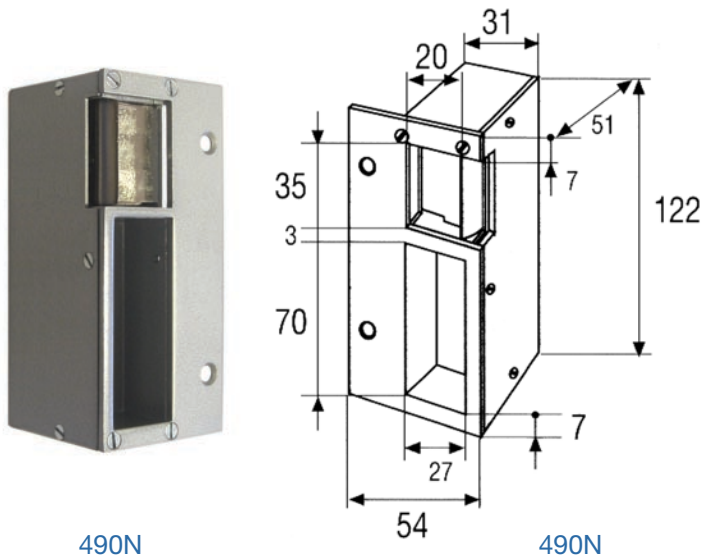

490N

490N

REFERENCES

- 3034 LOCK RELEASE MOD.490N
- 3035 LOCK RELEASE MOD.490Aa
- 3036 LOCK RELEASE MOD.490N-412
- 3037 LOCK RELEASE MOD.490N-512



VERTICAL LOCK

P Series. Panic

TECHNICAL FEATURES:

- For doors with panic bar.
- Reversible (Right DIN or Left DIN).
- Symmetrical.
- Concave latch adaptable to panic bar lock deadbolt.

Supplied in black as standard issue, along with 8 accessories 2,5 mm thick.
This model is installed in virtually all brands of panic bar lockset.

SPECIFICATIONS

Consumption:

N	12Vac:	980mA
N-412	12Vdc:	150mA
N-512	12Vdc:	150mA
N-424	24Vdc:	120mA

LOCK RELEASE TYPES / SURFACE

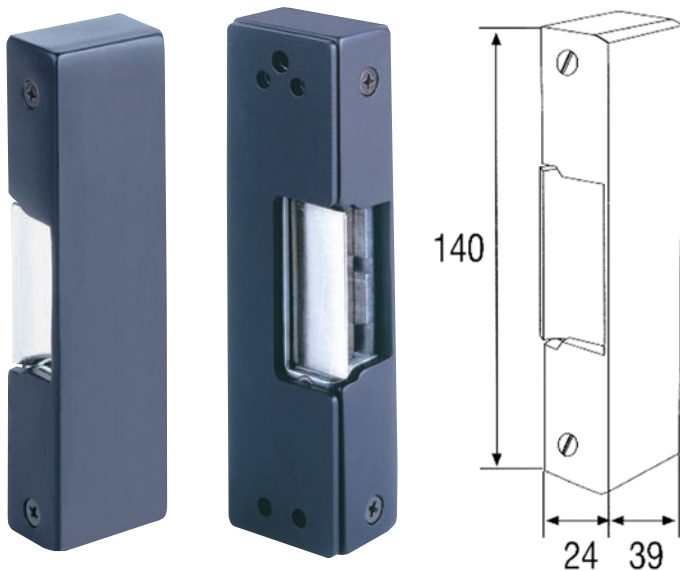

REFERENCES

- 3064 LOCK RELEASE MOD.PN
- 3065 LOCK RELEASE MOD.PN-412
- 3066 LOCK RELEASE MOD.PN-512
- 3067 LOCK RELEASE MOD.PN-424

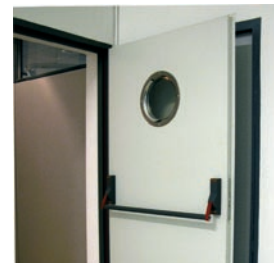

Panic bars

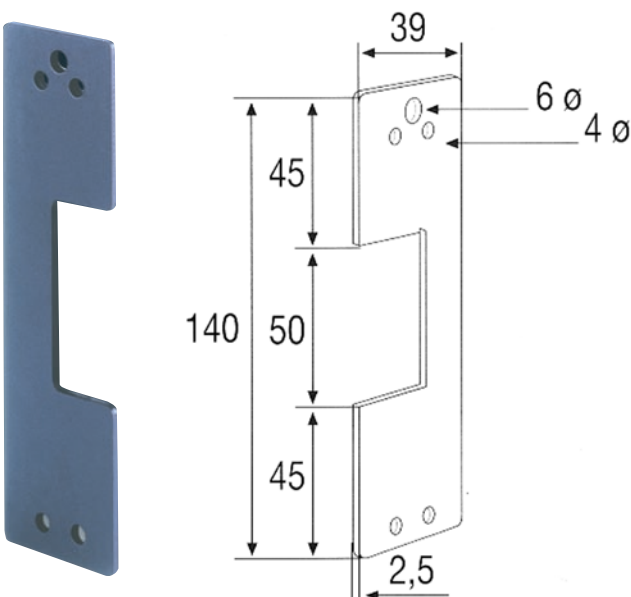

930 Series. Standard

TECHNICAL FEATURES:

- Reversible (Right DIN or Left DIN).
- The panic type latch is a piece with no apparent contact, as it is built into the mechanism and provides greater resistance to opening.
- Allows to change the door from left to right hand simply by turning the lock round.
- Supplied with assembly kit.

SPECIFICATIONS

Consumption:

12Vac: 850mA
12Vdc: 1,2A

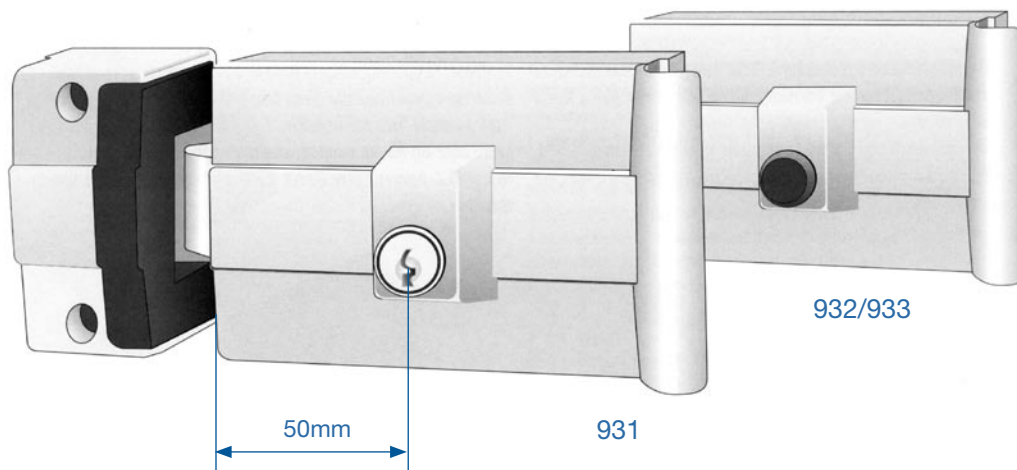

ELECTRIC LOCK BREAKDOWN

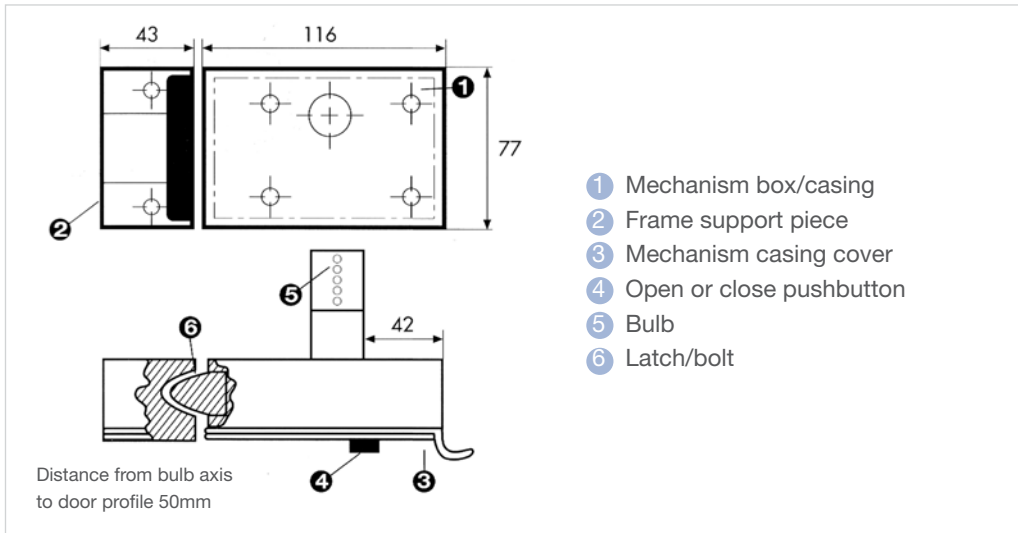

REFERENCES

- 3007 ELECTRIC RIM LOCK MOD.931-DOUBLE KEY
- 2991 ELECTRIC RIM LOCK MOD.932-W/KEY-PUSHBUTTON
- 3042 ELECTRIC RIM LOCK MOD.933-W/KEY-NO PUSHB. FUNCTION
Requires remote opening, as the button has no function.

960 Series. Replacement

TECHNICAL FEATURES

- Reversible outdoor electric lock with 50 mm cylinder.
- Key opening outside and pushbutton inside.
- Reversible (Right DIN or Left DIN).
- Symmetrical.

Its size and standard attachment points allow insertion into the majority of electric locks. The cylinder is adjustable from 50 to 70 mm.

SPECIFICATIONS

Consumption:
12Vac: 850mA
12Vdc: 1,7A
15W / 18W

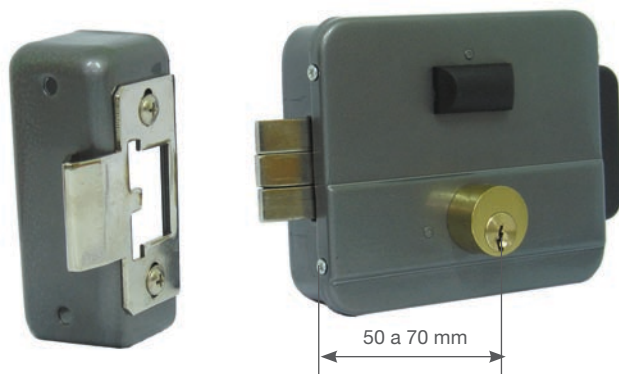

View of interior door part.

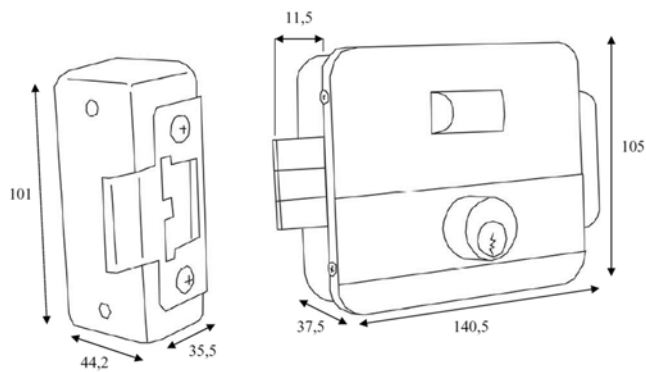

REFERENCES

2878 ELECTRIC RIM LOCK MOD.961-DOUBLE KEY

2879 ELECTRIC RIM LOCK MOD.962-DOUBLE KEY + PUSHBUTTON

(The exit button can be disabled through the indoor key, allowing the user to exit using a key or electric opening).

Hand change. Left - DIN Right - DIN

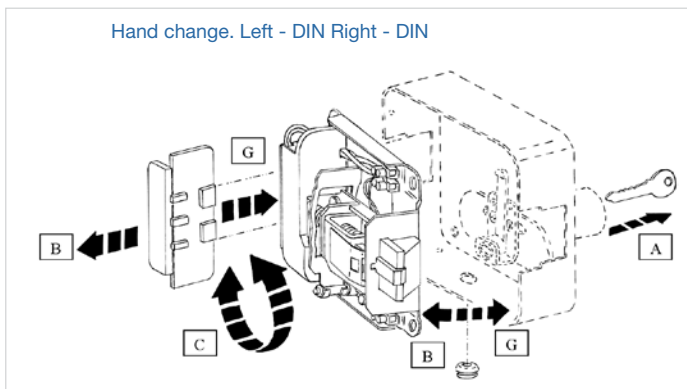

8000 Series. With chain

TECHNICAL FEATURES:

- Surface lock, with chain.
- Reversible (Right DIN or Left DIN).
- For surface locks with handle.

SPECIFICATIONS

Consumption:
12Vac: 980mA



REFERENCES

2984 LOCK RELEASE MOD.8000N WITH CHAIN

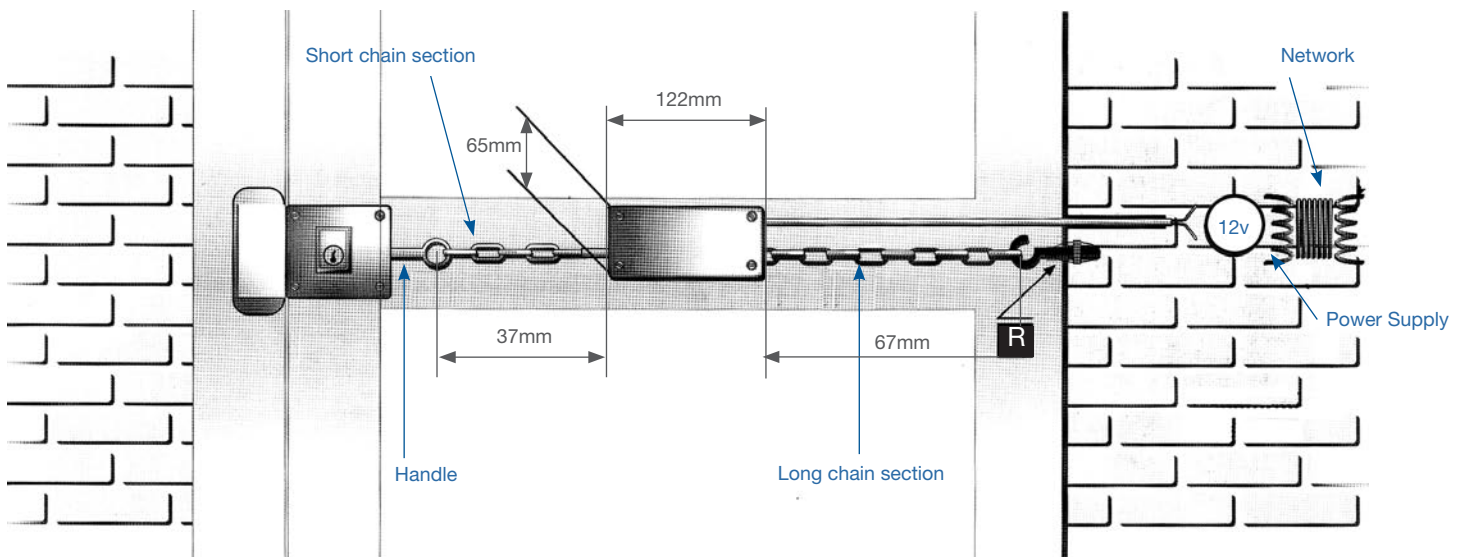

ASSEMBLY INSTRUCTIONS

Remove the cover and attach the shortest chain section to the lock handle. Tighten this section of chain to the limit, WITHOUT DISPLACING THE HANDLE, and fit the lock release firmly onto the door using the three attachment points on the inside. Now, part R (trigger force regulator), located at the end of the long chain, can be screwed onto the door frame. It may be necessary to remove a chain link. It can also be tightened simply by moving the threaded stud of the R part by turning the nuts fitted to it. Once the lock release is fitted, we can go ahead and wire up the electrical connection, check that it is working properly and finally replace the cover.

Crystal Series C. Double leaf

TECHNICAL FEATURES:

- For double leaf glass doors up to 12 mm.
- Surface lock release.
- Reversible (Right DIN or Left DIN).
- There is a hole on the inside to fit a handle to open the door manually and a pushbutton for electric opening.
- Simple assembly. To be secured using strong silicon glue and screws that lightly rub the glass. Not supplied with the lock release.

SPECIFICATIONS

Consumption:

N, A 12Vac: 980mA

Temperature: -40 to 120°C

Resistance (Kg): 260

Tested cycles: 200.000



CND

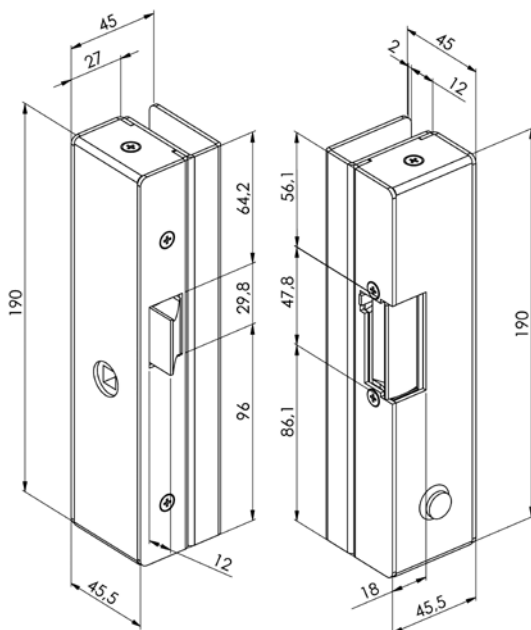

REFERENCES

- 2996 CRYSTAL LOCK RELEASE MOD.CN CHROME
- 2997 CRYSTAL LOCK RELEASE MOD.CND CHROME
- 2961 CRYSTAL LOCK RELEASE MOD.CA CHROME
- 2998 CRYSTAL LOCK RELEASE MOD.CAD CHROME

Electromagnetic Series

TECHNICAL FEATURES

- Allows to close a door without a traditional lock. Also useful to keep doors open for security purposes.
 - Electromagnetic lock releases the door when it is no longer powered.
 - Includes assembly kit and installation instructions.
 - Runs on 12 Vdc or 24 Vdc power supply.
- See installation instructions.*

SPECIFICATIONS

Consumption:
 12Vdc: 500mA
 24Vdc: 250mA

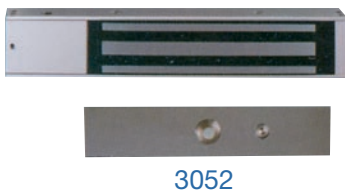

3052

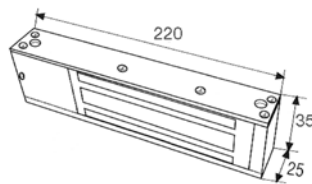

3078

REFERENCES

3052 SURFACE
 ELECTROMAGNETIC
 LOCK 300Kg.
 Holding force: 300N
 Bracket optional Ref.3078.

3078 BRACKET L-3
 FOR REF.3052

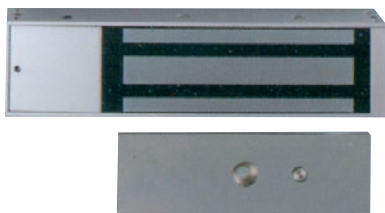

3051

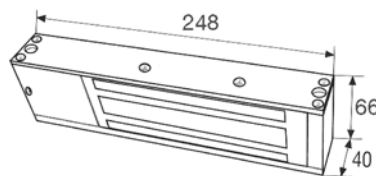

3077

3051 SURFACE
 ELECTROMAGNETIC
 LOCK 500Kg.
 Provides higher level security with 500 kg of pulling force.
 Recommended for high security entry points and outdoor accesses.
 Holding force: 5000N.
 Bracket optional Ref.3077.

3077 BRACKET L-2
 FOR REF.3051

ACCESSORIES



3079 Z DOUBLE BRACKET

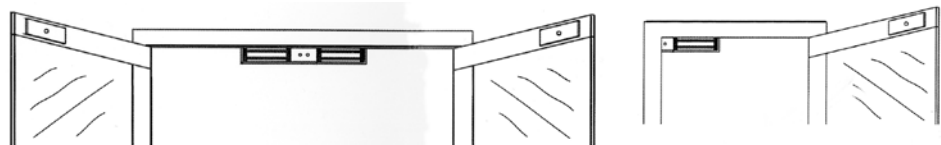

For double leaf: 2 units ref.3051 and 2 units ref.3077





ACCESSORIES

FERMAX

- SHIELDS
- CASES
- POWER SUPPLIES
- RETAINERS
- CONTACTS
- WIRE CONDUITS
- RELAYS



Shields. Flush-mounted lock release

Metallic trim coupled with an electrical mechanism forms a flush mounted lock release for access doors or latch/deadbolt entry doors. Choice of shield depends on the profile or material used in the door (aluminium, iron or wood).

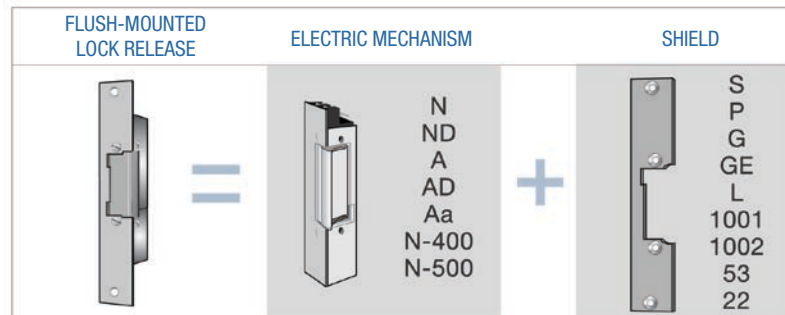

1. FOR ACCESS DOORS

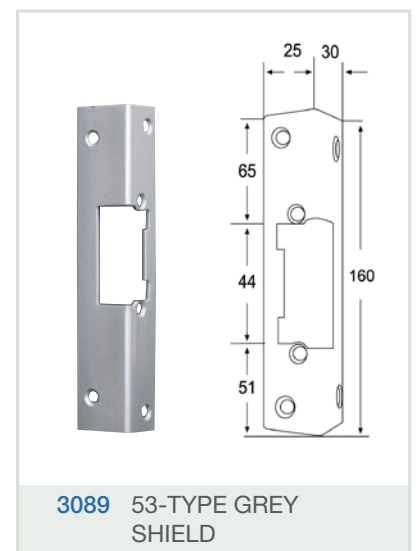
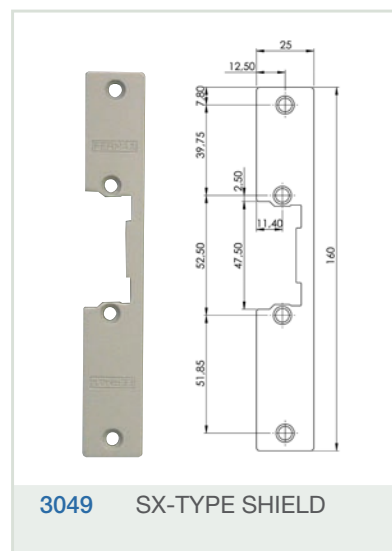
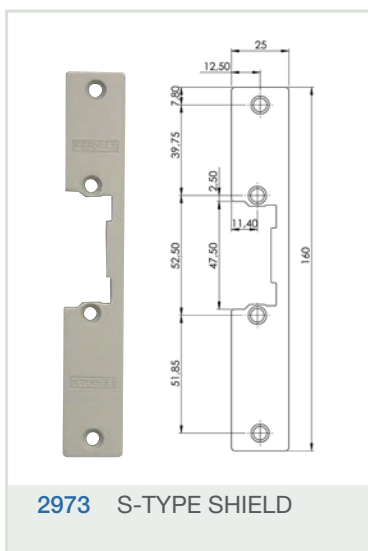
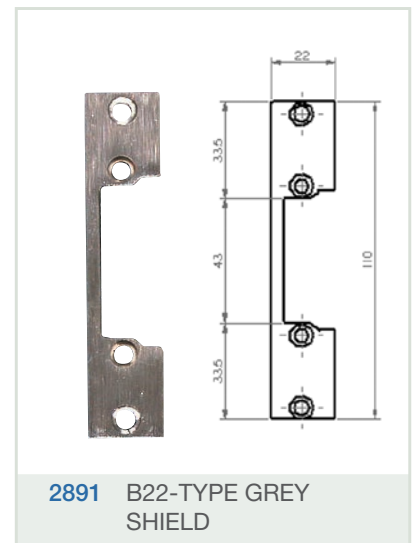
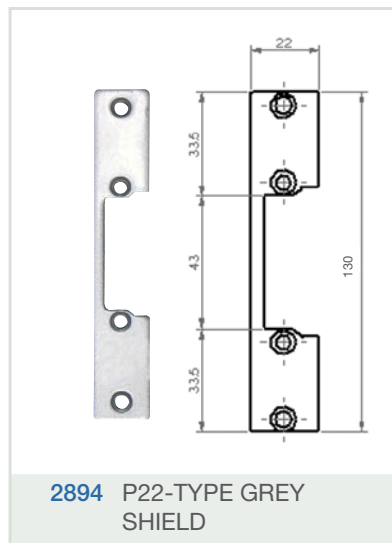
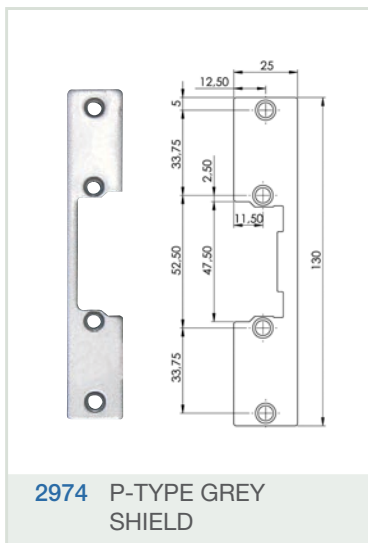

2. FOR LATCH-DEADBOLT LOCK DOORS

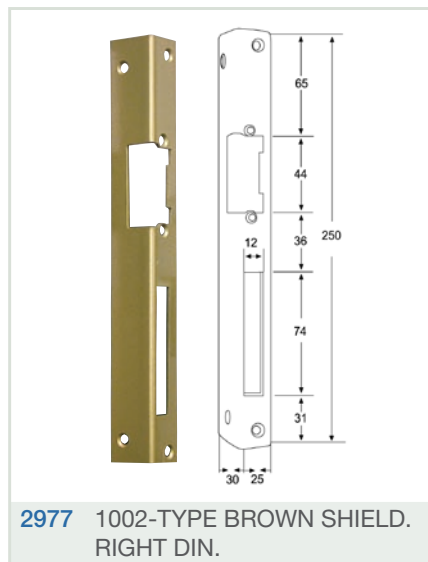
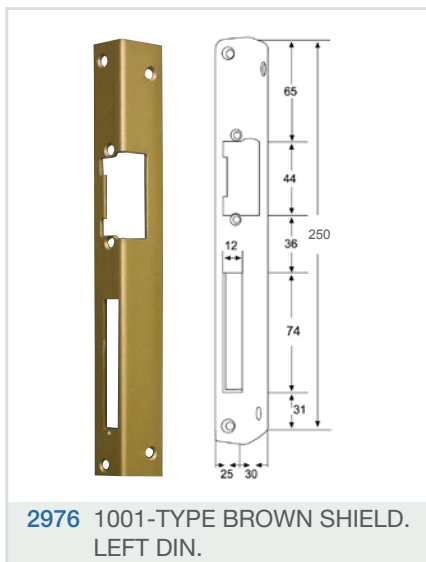
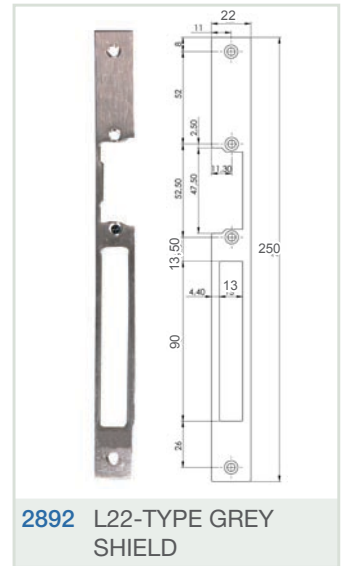
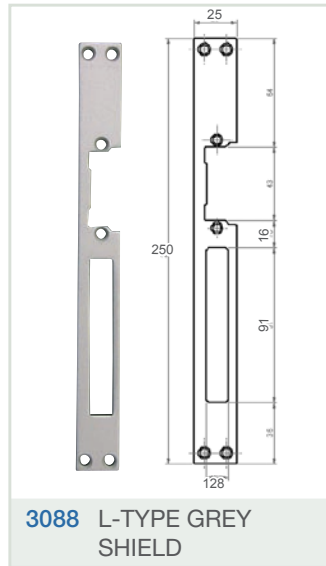
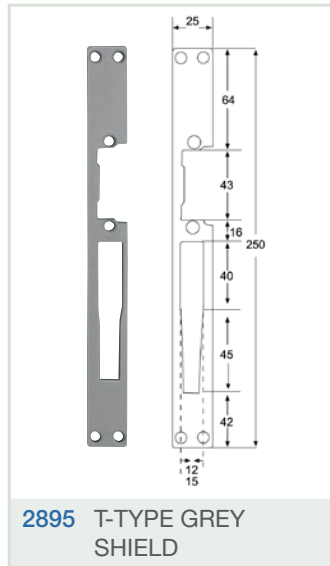
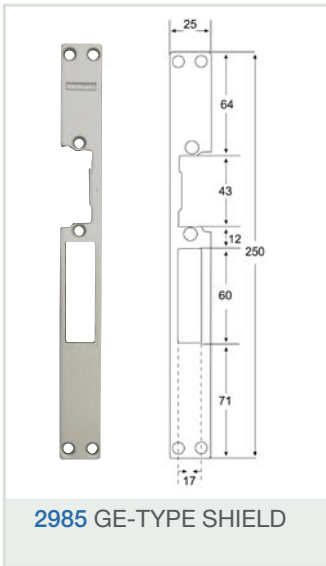
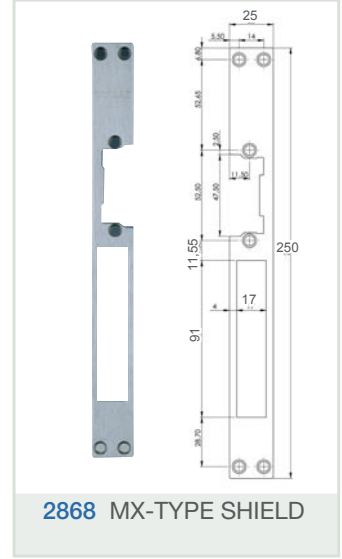
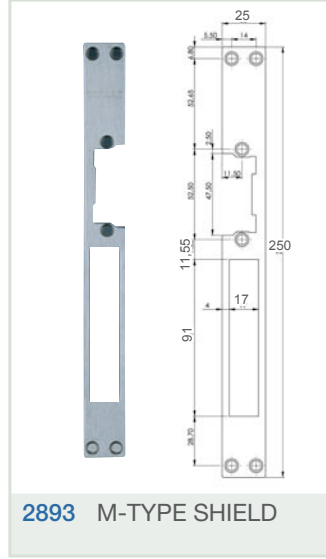
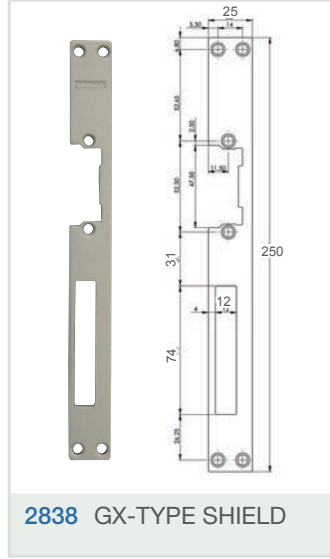
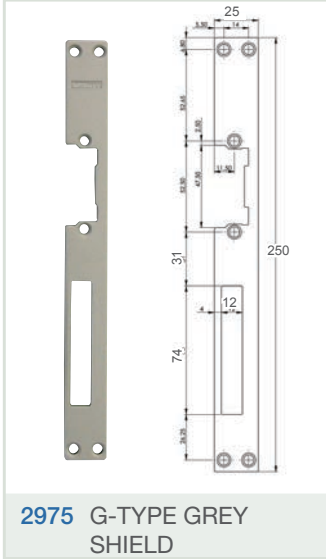

Cases. Surface lock release

Metallic trim along with an electrical mechanism makes up a surface-mounted lock release.

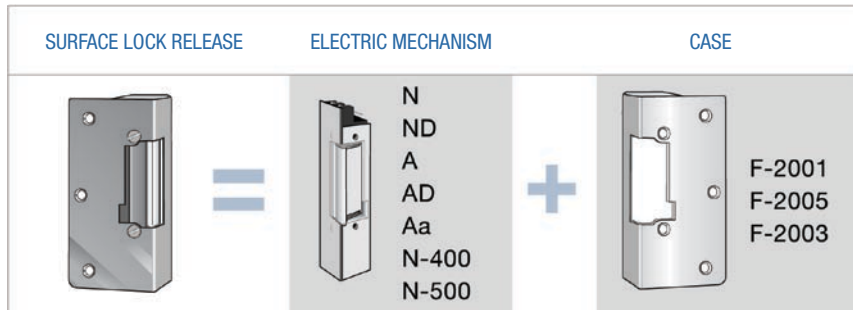

1. VISIBLE ATTACHMENT ON FRAME

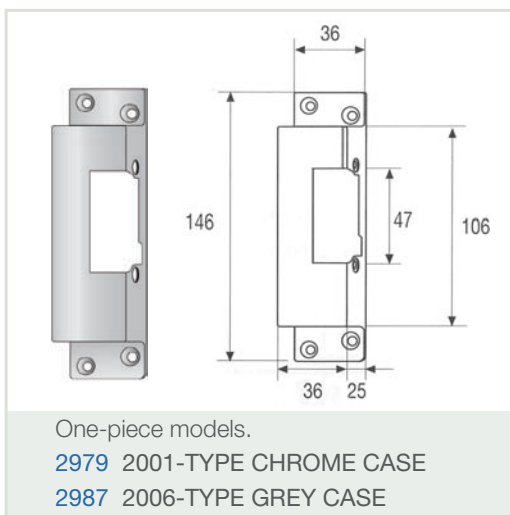

2. HIDDEN FRAME ATTACHMENT

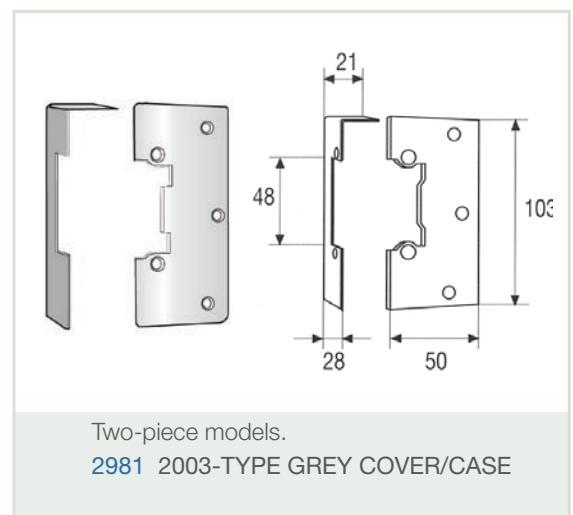
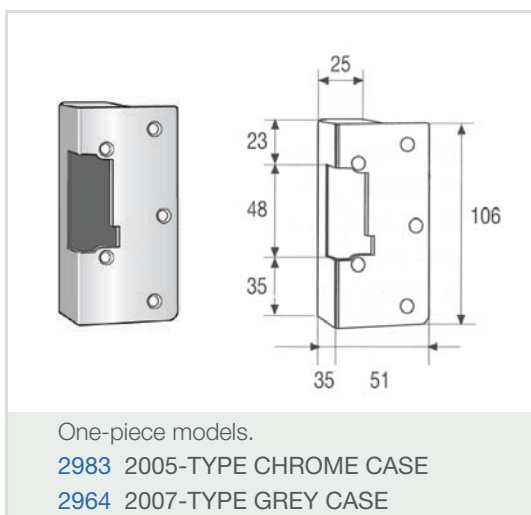

Power Supplies

DIN4 format. To power the lock release in AC (Vac) 1,5A.



4800 POWER SUPPLY 12Vac/1,5A

DIN6 format. To power the lock release in DC (Vdc) 2A.



4813 POWER SUPPLY 12Vdc/2A

In the event of power failure, it is necessary to fit it to an adaptor. This connects to a standard lead acid battery.



2060 EMERGENCY BATTERY ADAPTOR 12 Vdc

- 2070** BATTERY 12V/2,2A ACID LEAD
- 2337** BATTERY 12V/7A ACID LEAD
- 3264** ELECTRIC LOCK COMMANDER. Vac

Door retainers

Door retaining magnets, designed for fire doors, are supplied with the backing plate kit both fixed and moving. They are inverted operation at 24 Vdc with a holding force of 50 Kg.



2897 FLOOR RETAINING MAGNET 24 Vdc/50 Kg



2899 WALL RETAINING MAGNET 2 INPUT 24 Vdc/50 Kg



BACKING PLATE KIT

WALL RETAINER DIAGRAM

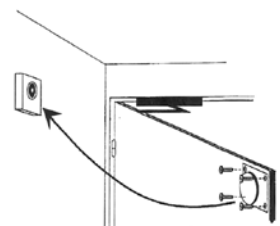

Contacts

The spring contacts are flush mounted in the frame and door respectively, leaving no visible wires, providing a reliable connection.

When the door is closed, the pistons that push against the other half keep up the electrical continuity desired. Approximate cut-off power: 1.5 Amp.

ACCESSORIES

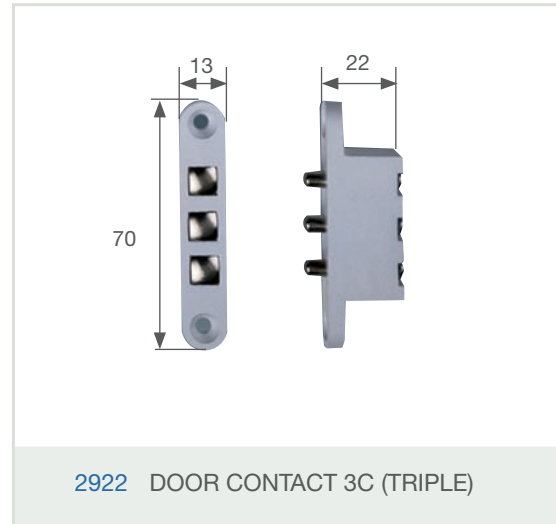
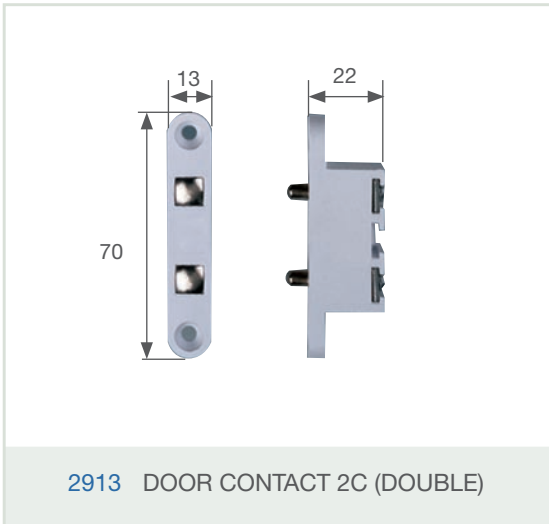

The 4C contacts with microswitch are installed in a long shield lock release (with latch/deadbolt). When locked with a key, the pin pushes the lever which then signals the microswitch. Recommended for installations where it is necessary to check if all the doors of a building are locked or to activate any electrical device (service fan, etc..)

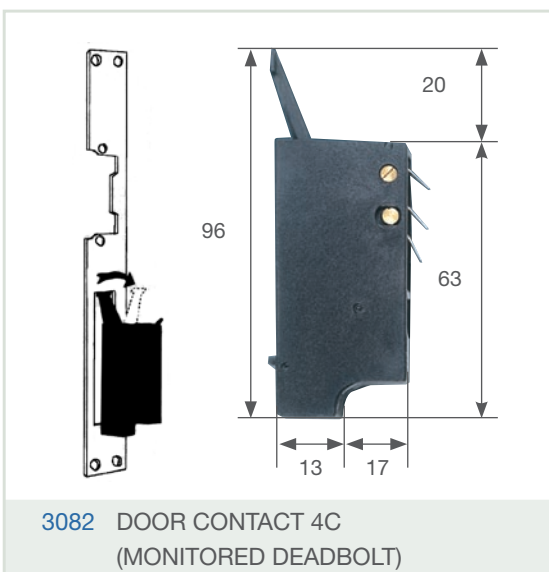

Cable conduits

Unlike spring contacts, they allow flow of current, even with the door open.

High quality flexible cable conduit (stainless steel) for surface mounting with external caps. Indicated when embedding contacts in the frame or door is not feasible.

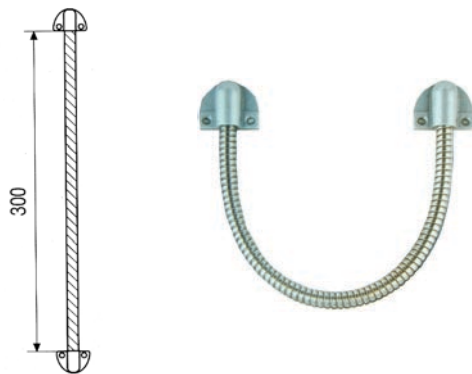

3083 FLEXIBLE CONDUIT

Vandal proof cable conduit with special structure allowing its flush mounting both in the door frame and panel. Can be fitted in metallic, wooden or PVC doors. Dimensions: 25(H)x330(V)x17(P) mm.



3084 RIGID VANDAL PROOF CONDUIT

Relays

Allows to invert lock release activation in combined installations with a Fermax lock release.

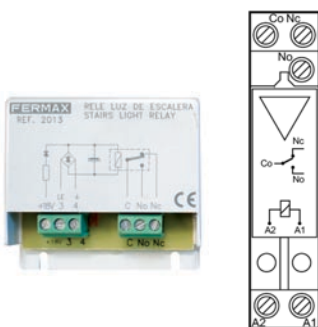

2013 RELAY 12Vac/12Vdc 2A
3491 RELAY DIN 12Vdc (220Vac/12A)

Recommended for additional functions. With 2 dry relay contacts, either normally open (NO) or normally closed (NC).

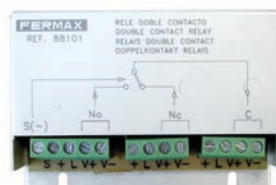

88101 RELAY 18Vdc DOUBLE CONTACT

Allows to time lock release activation for a programmable period from 0 to 6 minutes or 0 to 60 seconds.

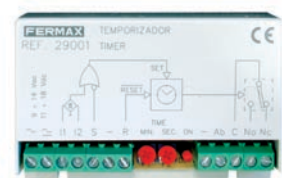

29001 TIMER





ACCESS CONTROL

FERMAX

RADIOFREQUENCY
CITYLINE MEMOKEY
CITYLINE PROXIMITY



Radiofrequency. 433 MHz

STORE SYSTEM

Trinary dip-switch configuration. Exit button input. Output 12Vac for electric lock activation. Power supply 230Vac. DIN6 casing. For electrical cabinets. Dimensions: 105x90x60.

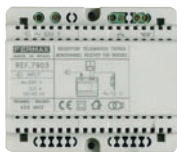

7903 RF RECEIVER SHOPS/STORES

For installation inside audio or video door entry systems.



7900 COMPATIBLE SINGLE-CHANNEL RECEIVER

Trinary dip-switch configuration. A single code for all emitters.



79561 DUAL CHANNEL EMITTER 433 MHz TRINARY

SECURITY SYSTEM

Maximum 10 users. Exit button input. Output relay (2A,NC/NA). Programmable timing. Monostable/bistable operation. Power supply 12v AC/DC. Small dimensions, for concealing in electrical closets. Dimensions: 90x60x20.



7960 SECURITY RECEIVER

COLLECTIVE GARAGE SYSTEM

Trinary dip-switch configuration. Admits extension card for a 2nd channel for auxiliary activation (e.g. lift/elevator). Relay output (2A,NC/NA). Power supply 230Vac. ABS IP65 casing. Dimensions: 91x198x57.



7952 SINGLE-CHANNEL RECEIVER 433MHz
7934 SECOND-CHANNEL CARD

Digital transmitters have one unique code per user. Indicated for access to the garage/car park and remote control of devices: lights, shutters, sirens...



24651 DIGITAL EMITTER

Trinary dip-switch configuration. A single code for all emitters.



79561 DUAL CHANNEL EMITTER 433MHz TRINARY

Cityline Memokey

TECHNICAL FEATURES:

- Maximum capacity: 100 codes.
- Power supply 12Vac/12Vdc. Power supply 12Vac/1,5A (ref.4800) recommended.
- Input for indoor exit pushbutton.
- Input for free access pushbutton.
- 2 relay outputs (2A,NC/No), for lock release activation and alarm connection. Programmable timing.
- Each code can activate one or two relays simultaneously.
- Code accepted/rejected acoustic confirmation.
- Programming from keypad with master code.

SPECIFICATIONS

Dimensions:	
Reader	130x128
Flush box	115x114x45
Surface box	130x128x33
Environmental protection (IP):	54
Shock resistance (IK):	07
Power supply (V):	12 Vac/dc
Consumption (mA) w/lock.:	40/110
Operating temperature:	-15° to 55° C



REFERENCES

- 6991** CITYLINE MEMOKEY READER
 Outdoor/Indoor. Integrated in aluminium panel. Backlit keypad manufactured in zamak with signal LEDs.
 Flush box included (ref.8948). Surface box optional (ref.7061).

INSTALLATION

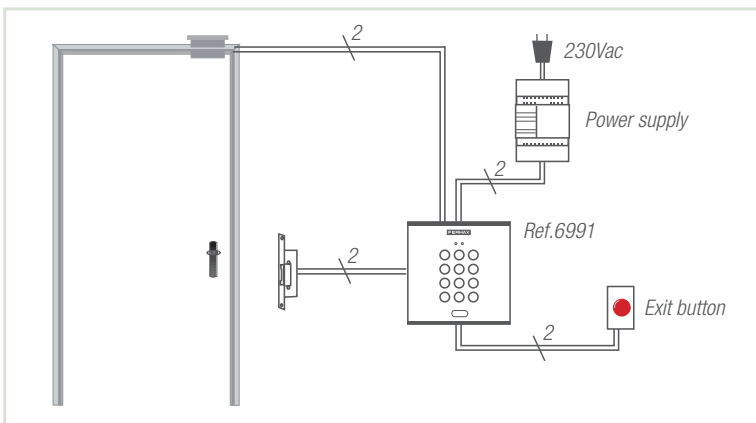

Cityline Proximity

TECHNICAL FEATURES:

- Up to 400 users.
- Power supply 12 Vac/Vdc. Power supply 12Vac/1,5A (ref.4800) recommended.
- Exit button input.
- Door sensor input. Forced/open door detection.
- Lock release triggered by relay. Programmable timing.
- LED and buzzer confirm acceptance or rejection of the card presented.
- Programming help LEDs (authorizations, cancellations).
- User programming from reader using master card or by PC (optional).

SPECIFICATIONS

Dimensions:	
Reader	130x128
Flush box	115x114x45
Surface box	130x128x33
Environmental protection (IP):	54
Shock resistance (IK):	07
Power supply (V):	12 Vac/dc
Consumption (mA) w/lock.:	90
Operating temperature:	-15° to 55°C

CONTROL DE ACCESOS



REFERENCES

- 6992** CITYLINE PROXIMITY READER
Outdoor/Indoor. Integrated in aluminium panel. Flush box included (ref.8948). Surface box optional (ref.7061).
- 2306** PROGRAMMING KEYPAD
- 24661** READER-PC INTERFACE
For managing user authorizations/cancellations via PC (optional). The WINPROX software may be downloaded from www.fermax.com

Identifiers



- 23361** PROXIMITY CARD WITHOUT MAGNETIC STRIP
- 2336** PROXIMITY CARD WITH MAGNETIC STRIP
- 44501** PROXIMITY KEYRING

INSTALLATION

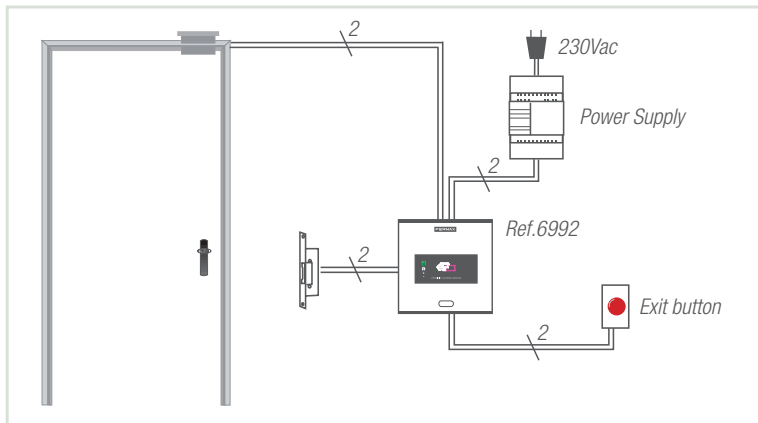

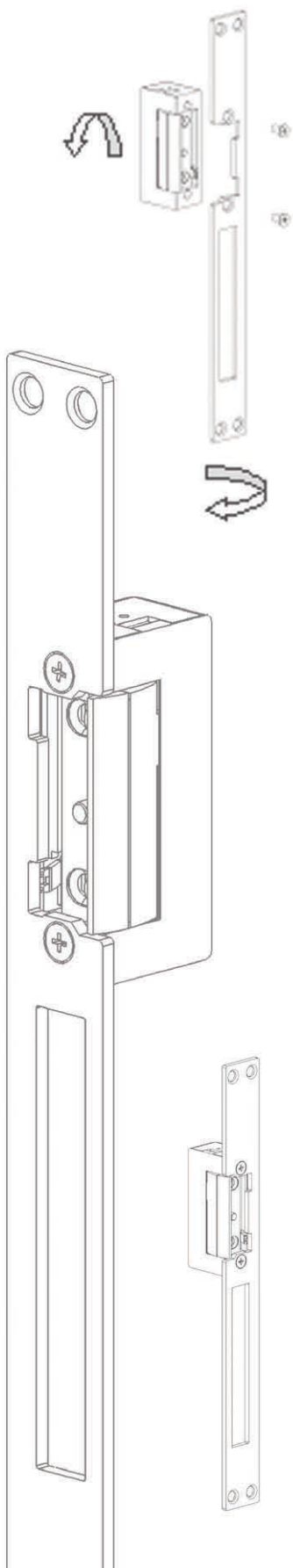

**ASSEMBLY
INSTRUCTIONS**

FERMAX

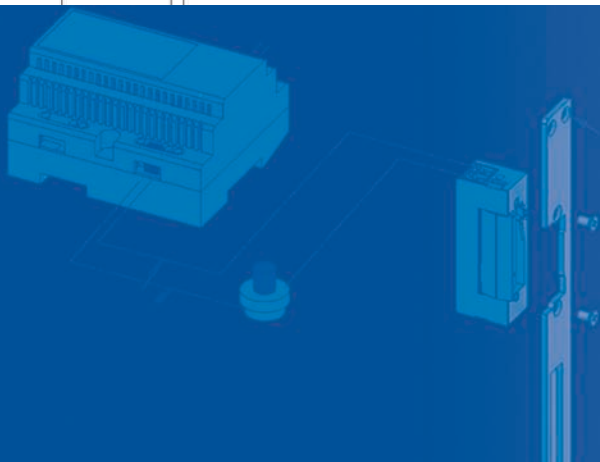

Hand change: Left DIN - Right DIN



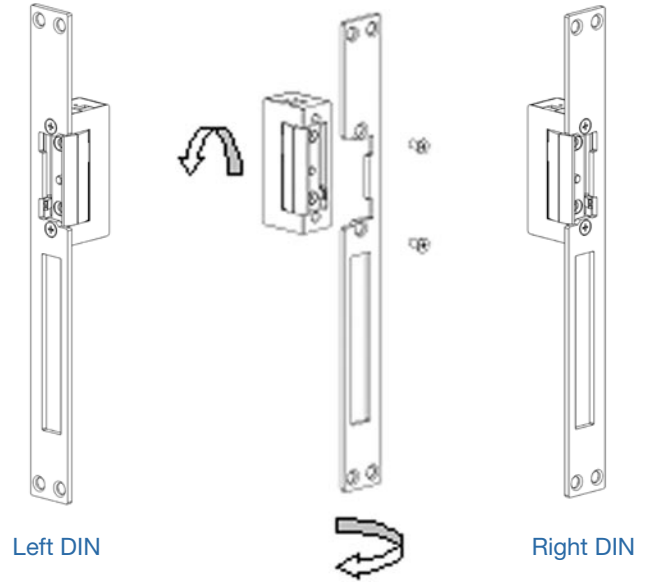
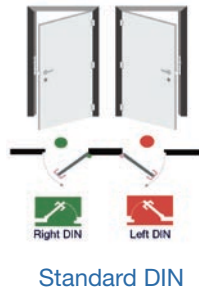

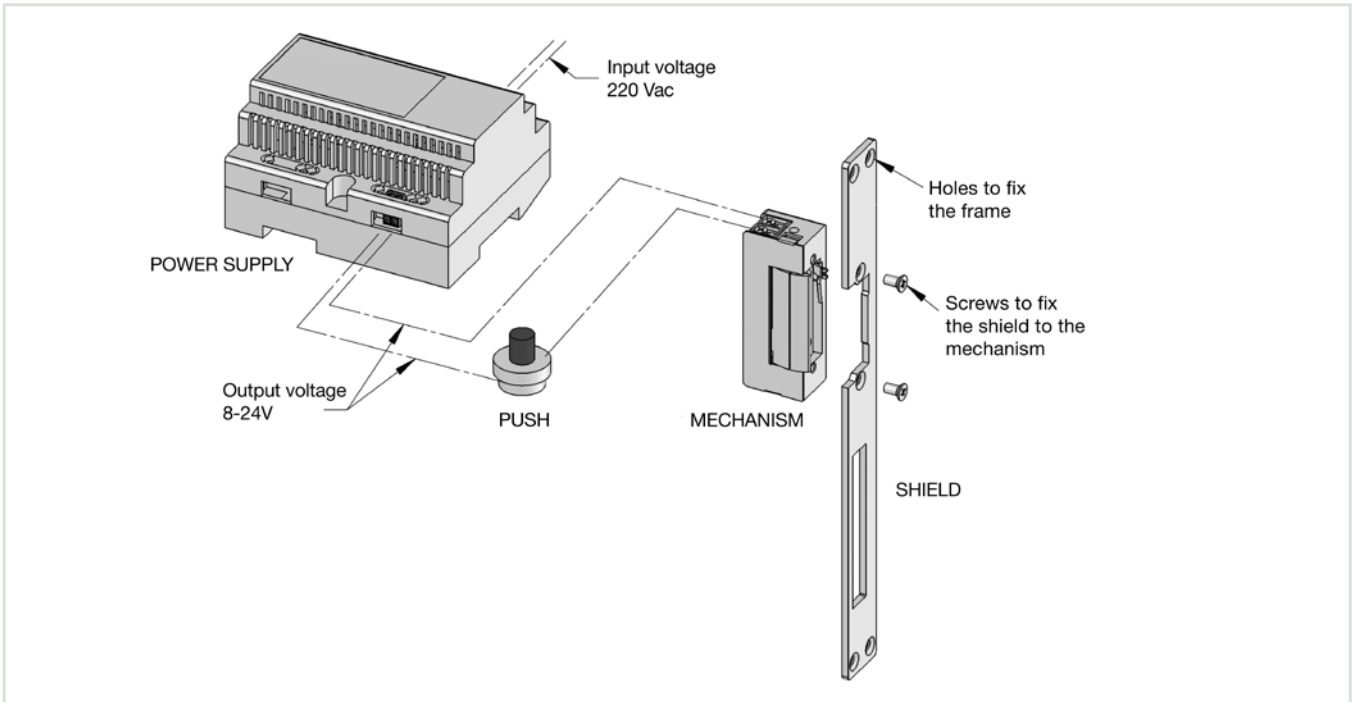

- 1 Remove the screws on the front, removing the shield from the mechanism.
- 2 Turn the shield 180° horizontally and the mechanism vertically.
- 3 Screw back on again to fit the shield to the mechanism.



ELECTRICAL INSTALLATION



ASSEMBLY TIPS

-  Before making electrical connections, please check the lock release electrical specifications as well as the voltage and type of current supplied by the power supply.
-  Remove any remaining traces of material from the framework where the lock release will be introduced.
-  Do not apply any kind of paint or coating to the lock release or its shield.
-  Do not grease the mechanism.
-  Do not remove the mechanism cover.
-  Keep the lock release free from moisture.

Lock assembly

- 1 Close the door and mark the latch position (and the deadbolt if there is one) on the frame to define the vertical position.

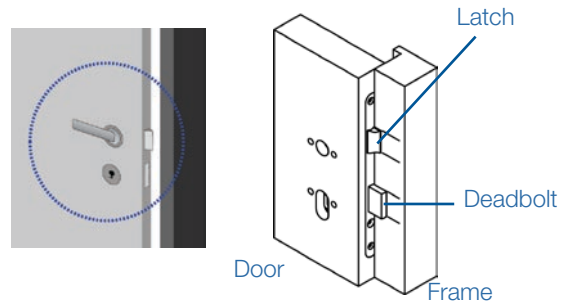

- 2 Align the flat surfaces of the latch and the lock release deadbolt so that they are parallel and with a minimum clearance, so that the latch does not exert pressure on the lock release bolt. Measure the distance indicated with which you can define the horizontal position.

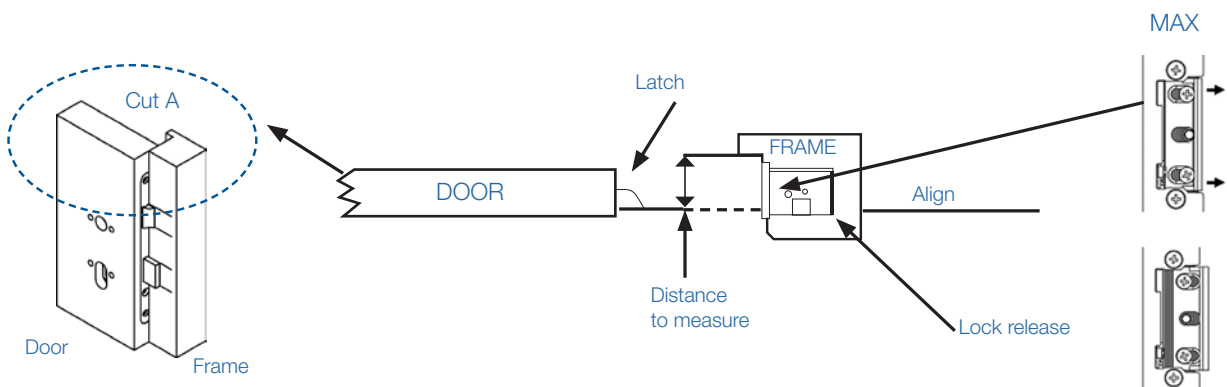

NOTE: With automatic mechanisms A, the latch must press on the bolt mechanism (approx. 3mm) for it to work automatically.

The MAX version adjustable latch allows an exact fit between latch and bolt up to 4mm.

- 3 When the vertical and horizontal position of the lock release has been defined, make a hole in the door frame to fit the mechanism and lock. The box housing and lock mechanisms must have a minimum depth of 31mm (or higher for series 620, 460, 470 or if the lock bolt requires more depth).

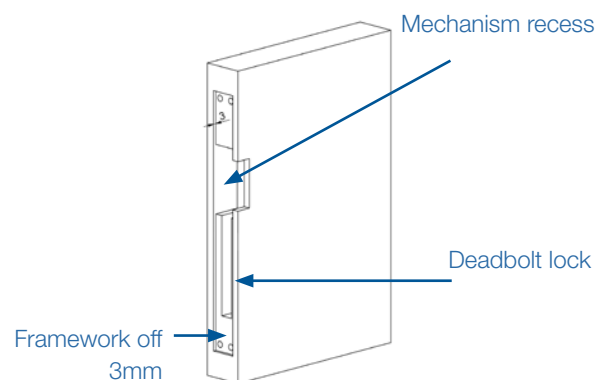

- 4 Make a 3mm framework to fit the shield, to keep it in the same plane.

Lock assembly

- 5 Additionally, a fitting is needed on the side for movement of the 5 lock release latch/bolt. In the 410 Series this is no longer required, as it has a radial latch.
- 6 Mark the holes for the anchor screws. Must be drilled to fit the holes in the shield
- 7 The wiring hole must be made inside, near the lock release casing.

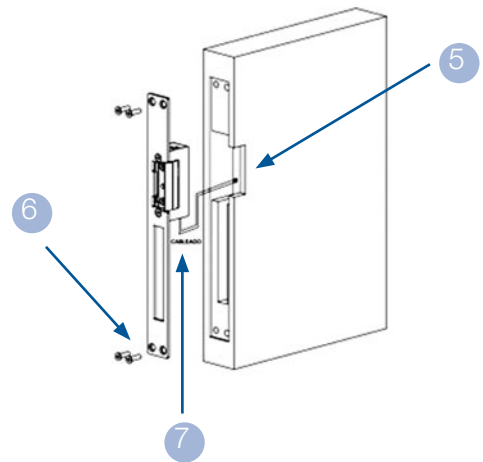

- 8 Connect the wires. Fit the lock release in the recess and tighten the holding screws.

The shield surface and frame must be on the same plane so that the door can close properly.

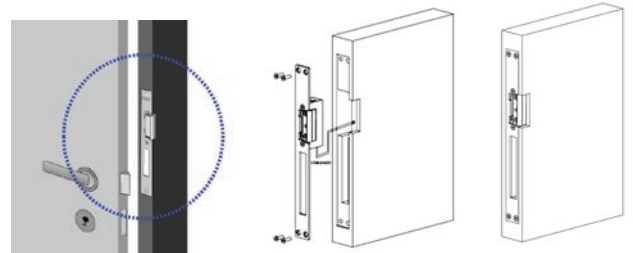

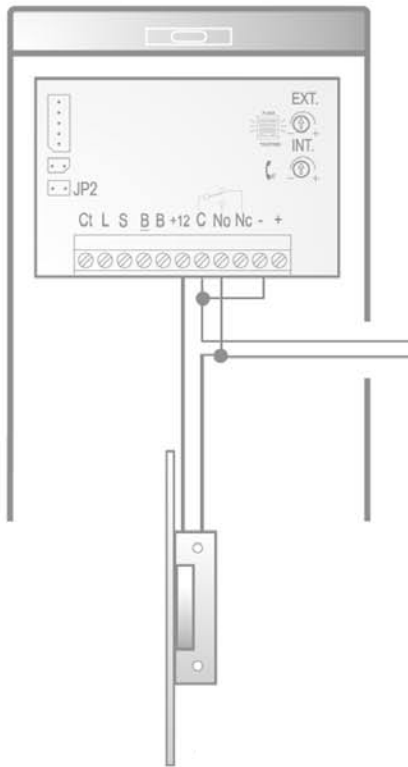
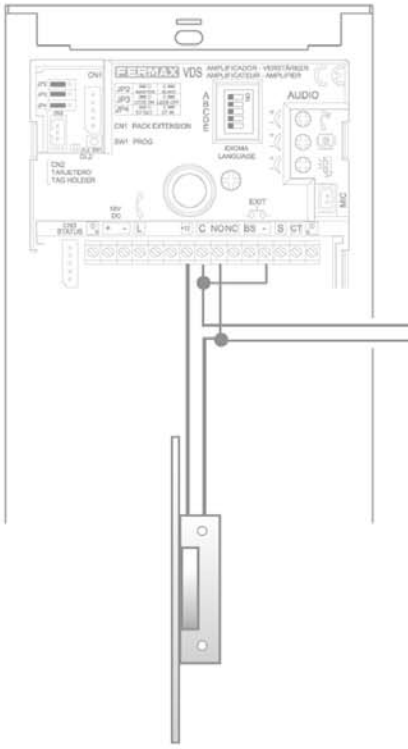

INSTALLATION DIAGRAMS

FERMAX

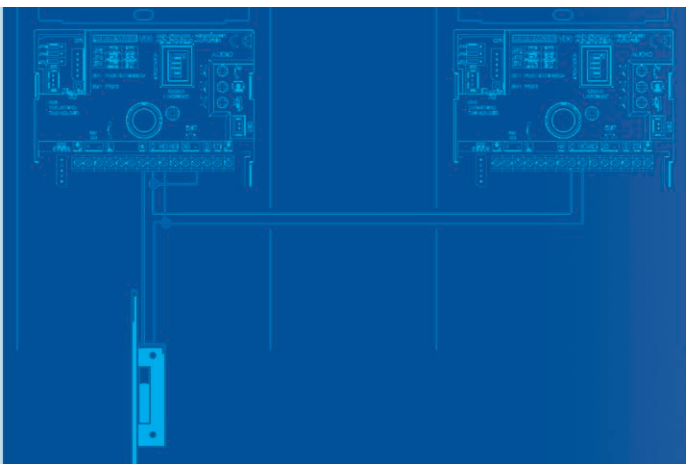

DOOR OPENING BY LOCK RELEASE OPERATION

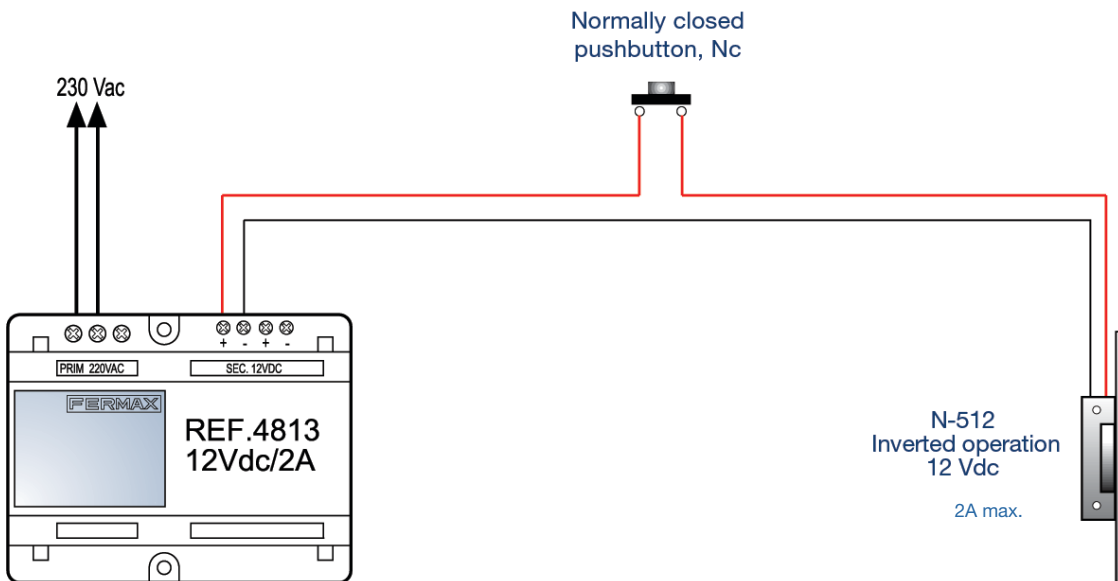
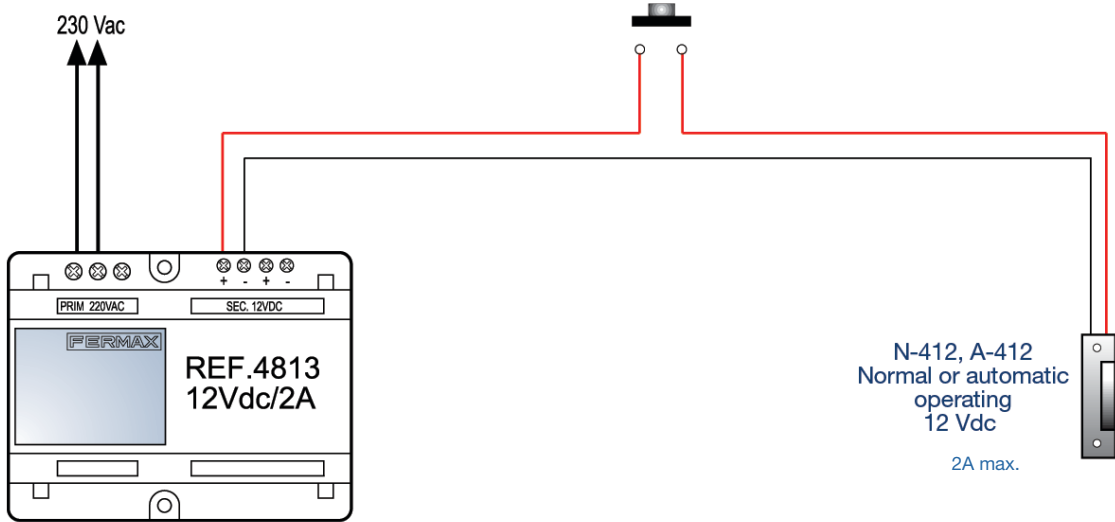
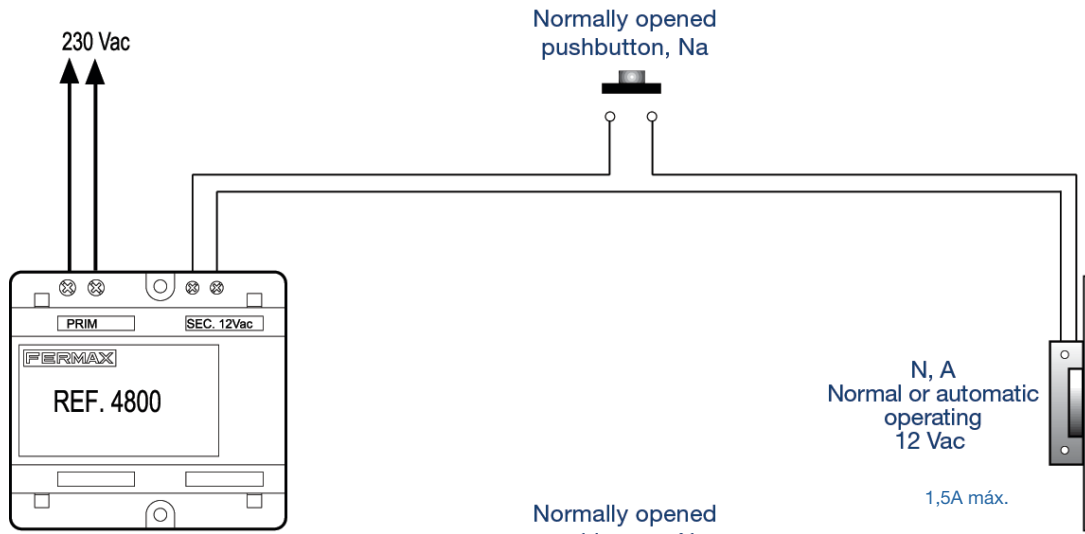

DOOR OPENING WITH AUTOMATIC BLOCKING OF ANOTHER DOOR.

NORMAL OPERATION 12 Vac

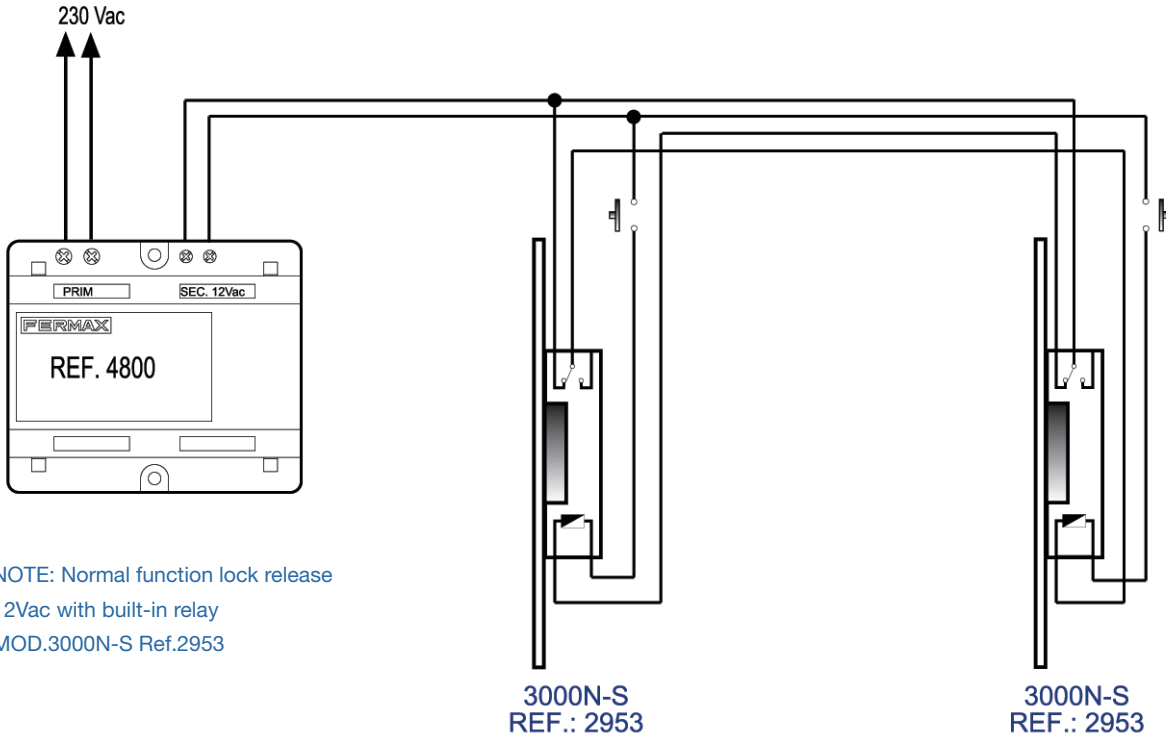

NOTE: Normal function lock release
12Vac with built-in relay
MOD.3000N-S Ref.2953

INVERTED OPERATION 12 Vdc

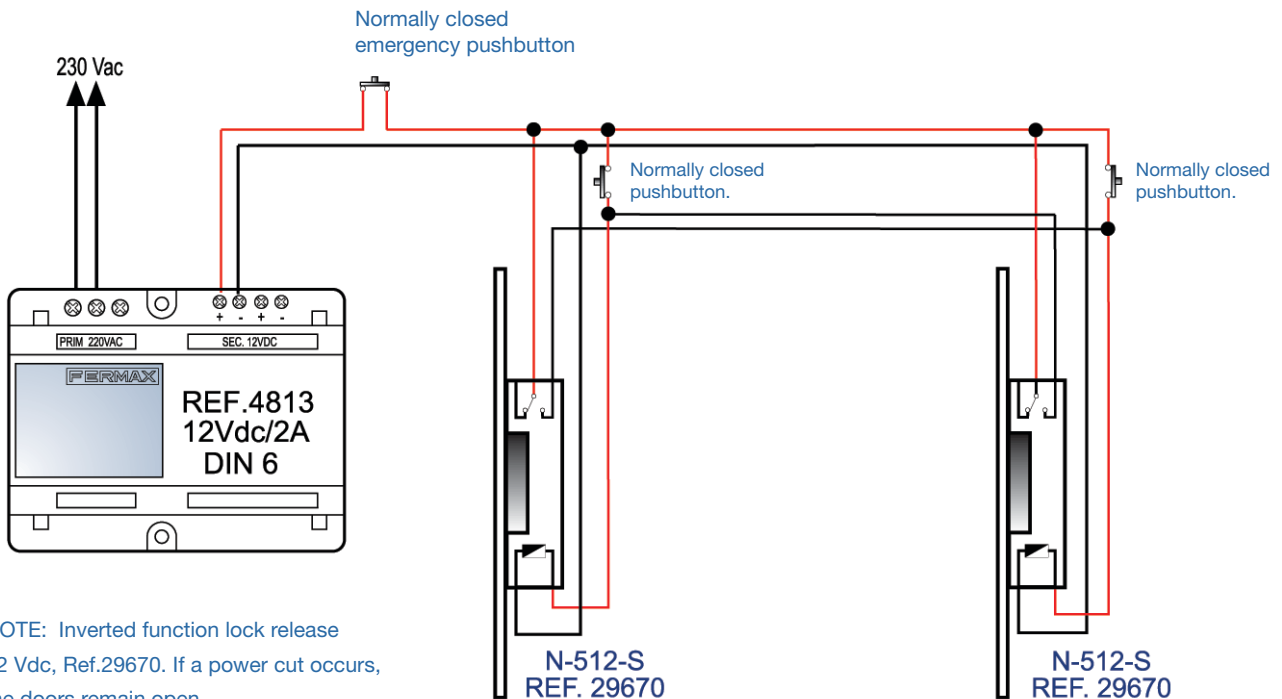

NOTE: Inverted function lock release
12 Vdc, Ref.29670. If a power cut occurs,
the doors remain open.

INSTALLATION WITH RELAY REF.2013 ACCORDING TO LOCK RELEASE OPERATING TYPE

INSTALLATION DIAGRAMS

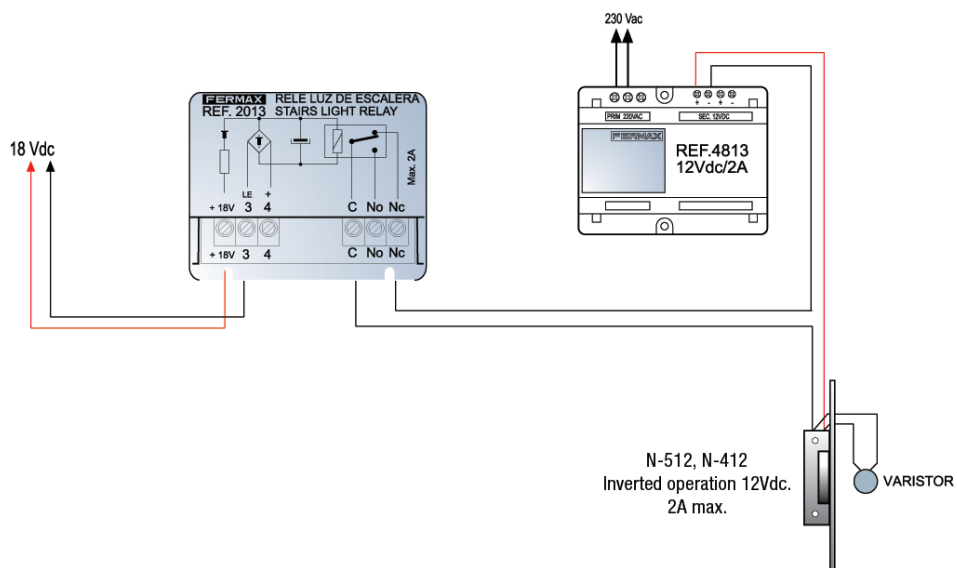
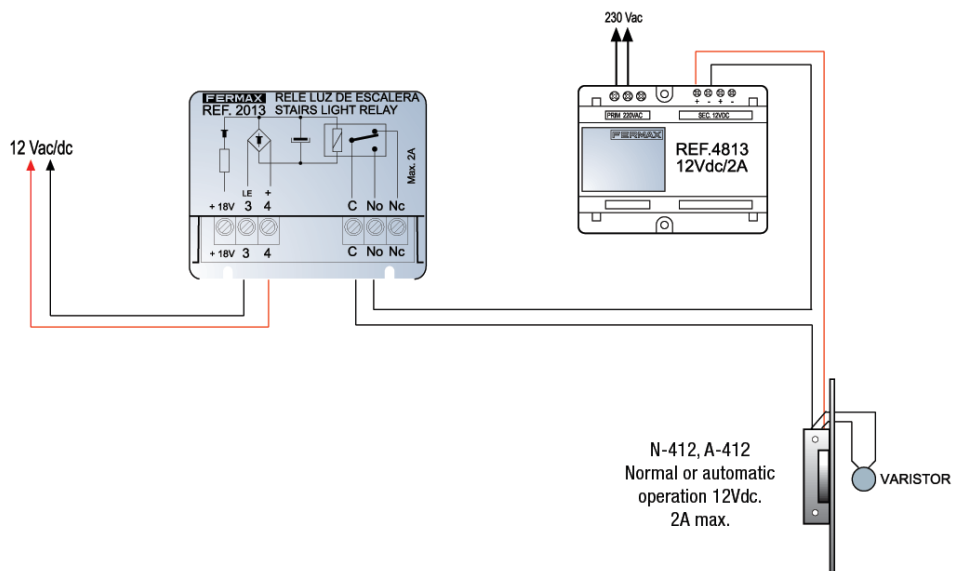
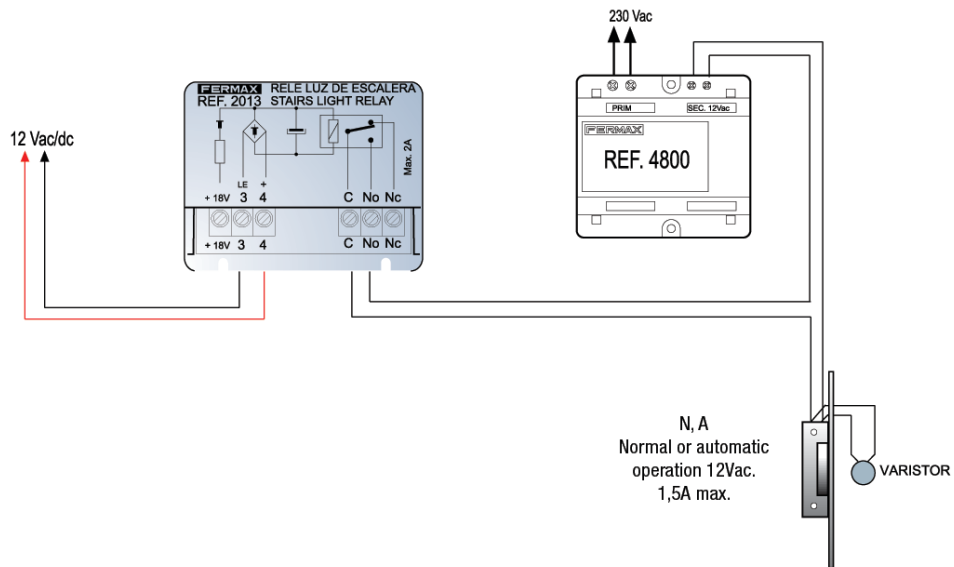

VDS/ADS DOOR OPENING WITH TIMER

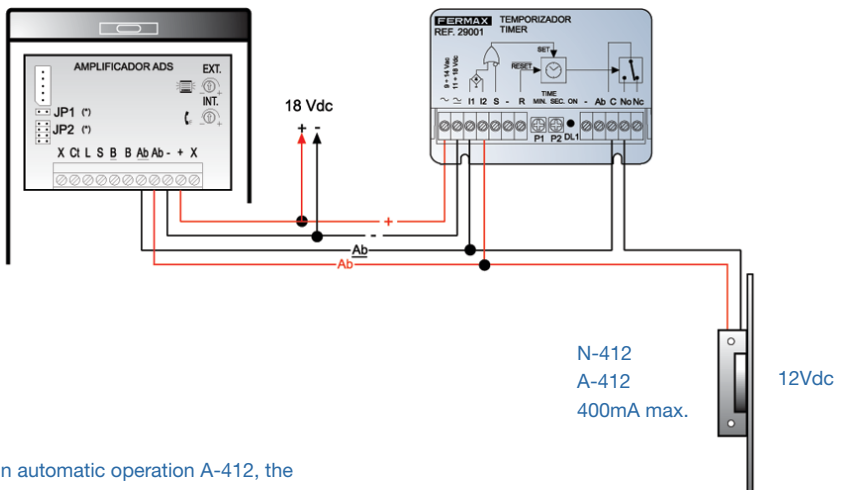
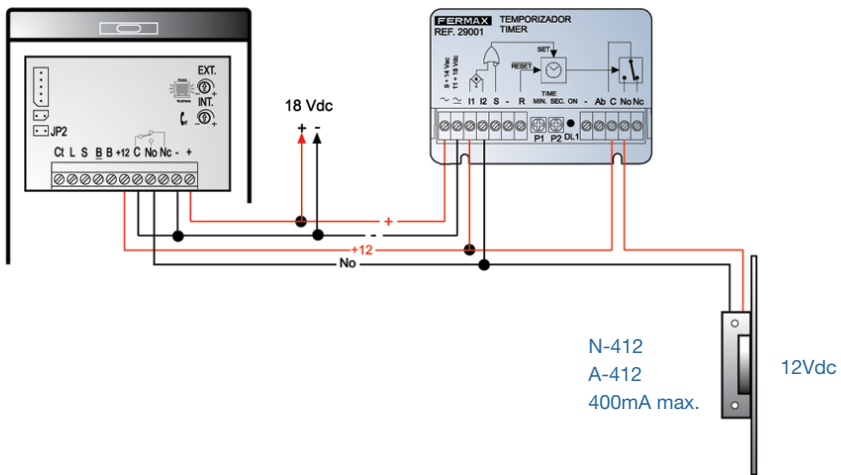
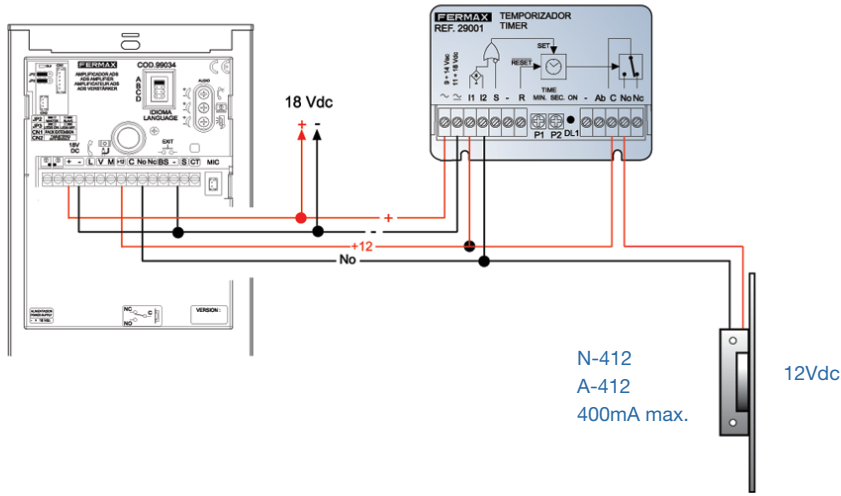

* In automatic operation A-412, the timer is set for a short opening time.

OPENING THE SAME DOOR (12Vdc)

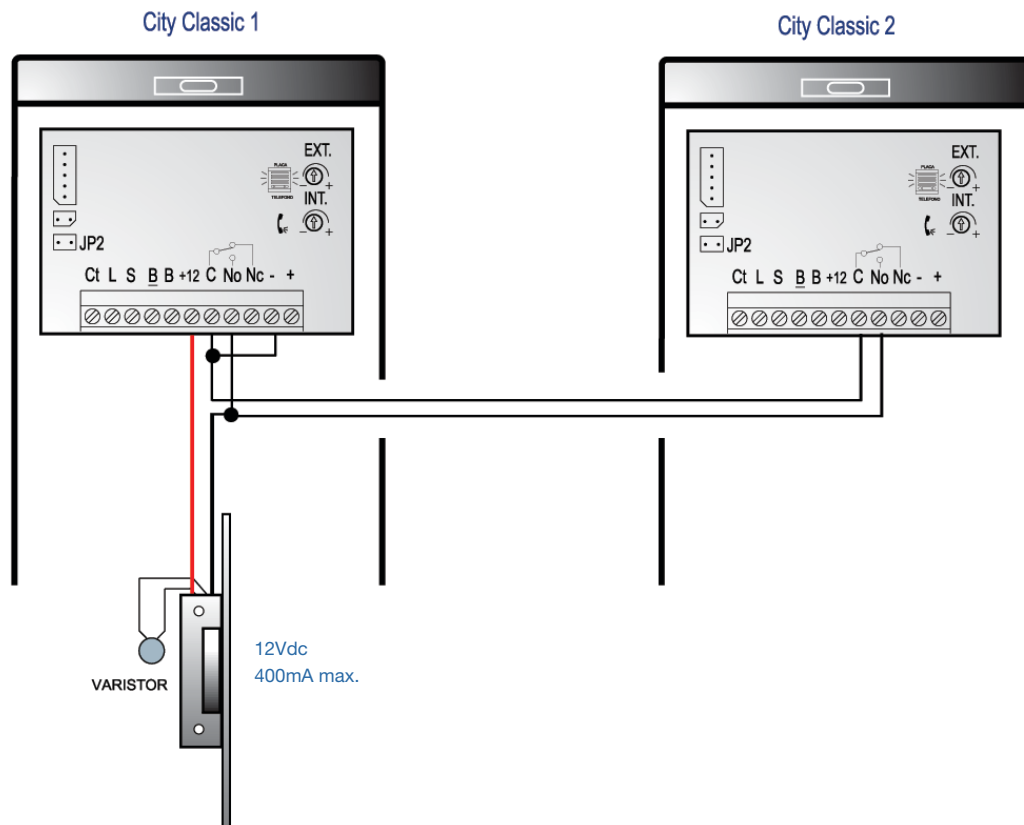
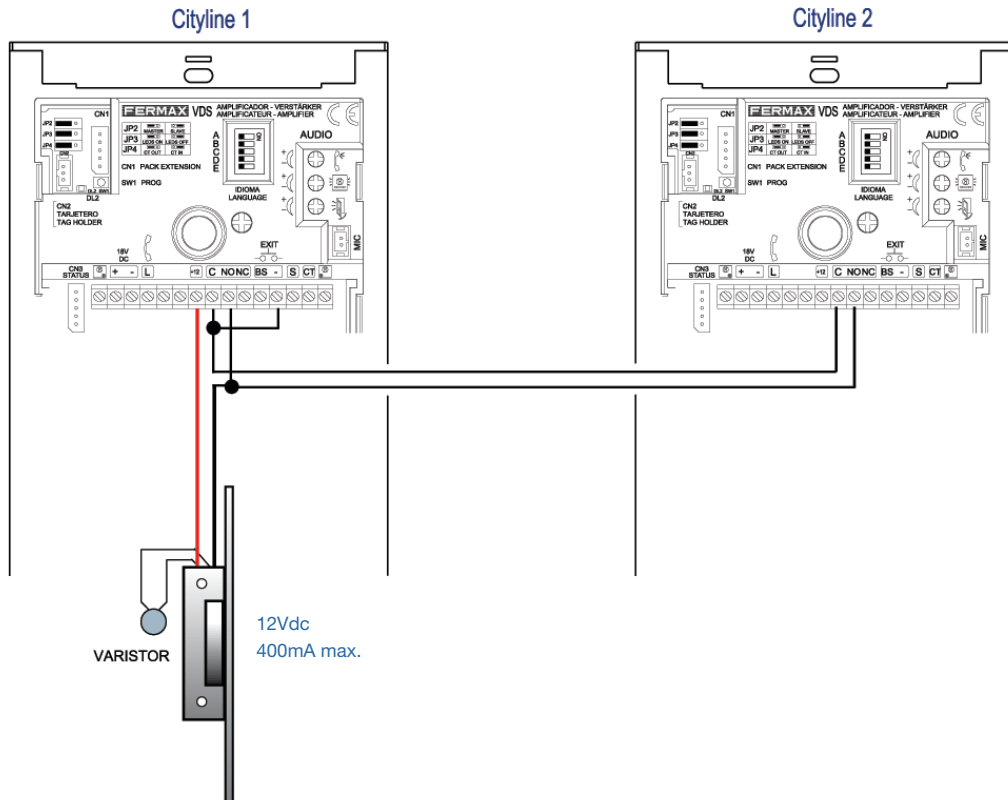

OPENING THE SAME DOOR (12Vac)

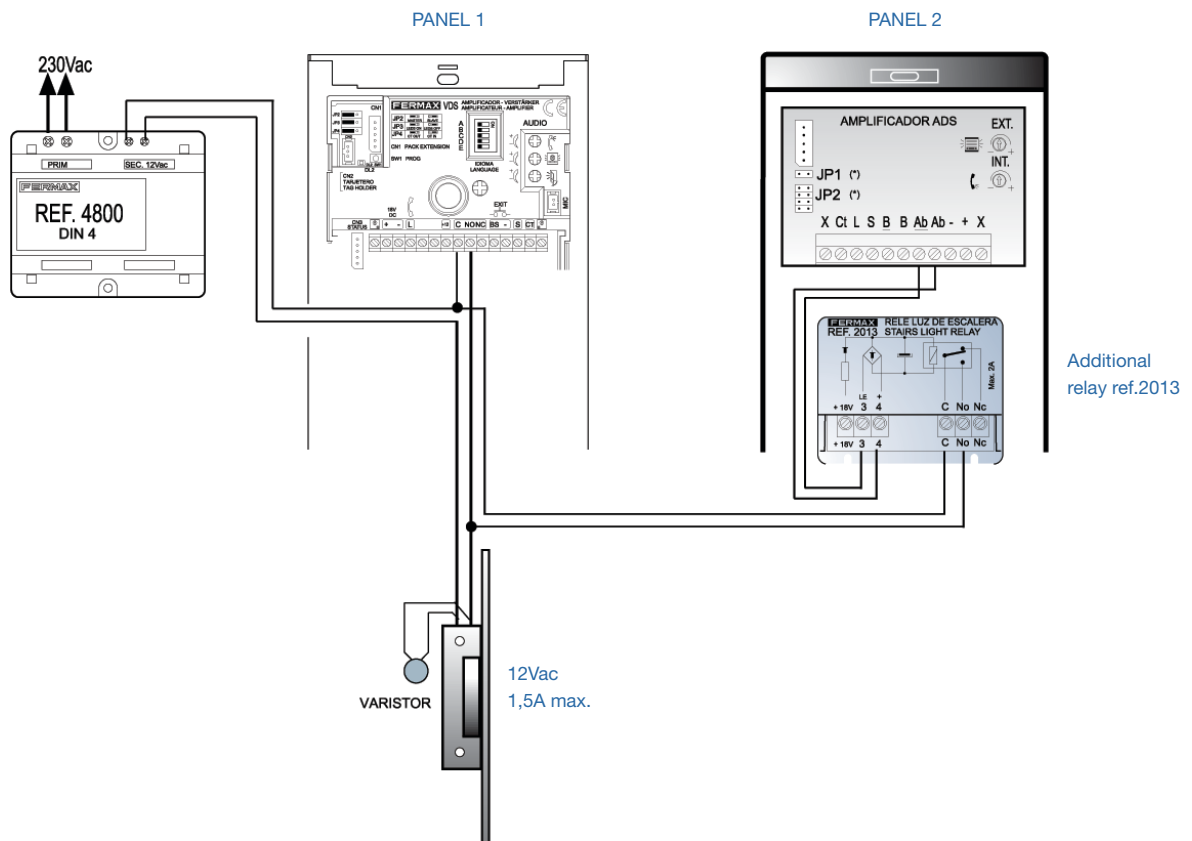
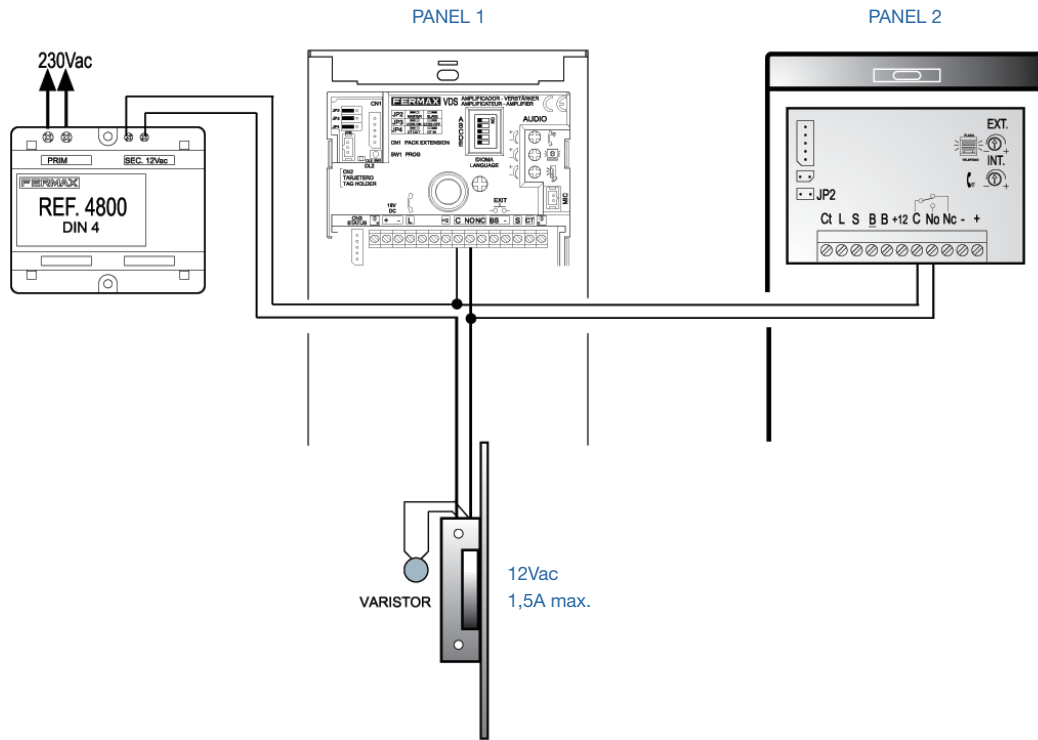

REMOTE CONTROL OPENING. RECEIVER REF.7960

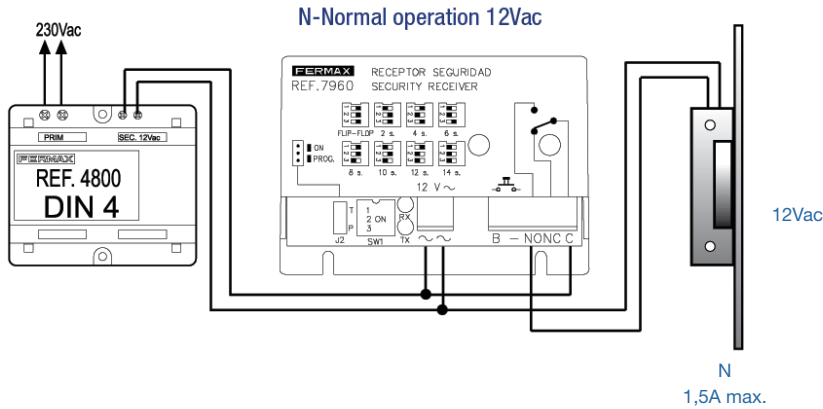

Monostable receiver configuration. Each pressing of the emitter will open the door during 4s.

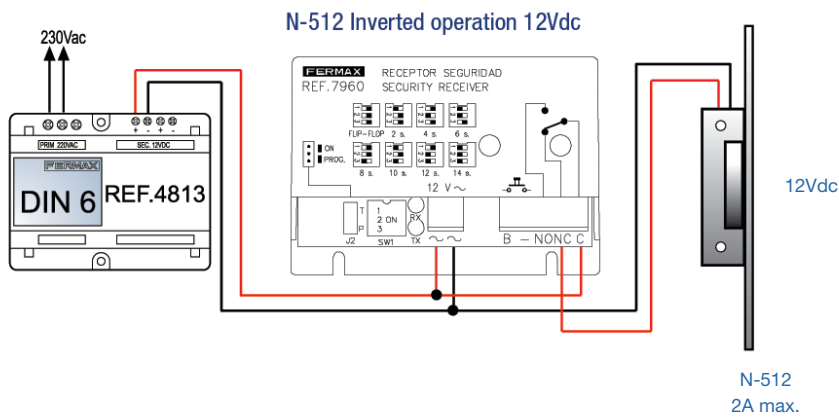

Monostable receiver configuration. Each pressing of the emitter will open the door during 4s.

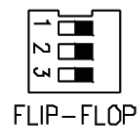
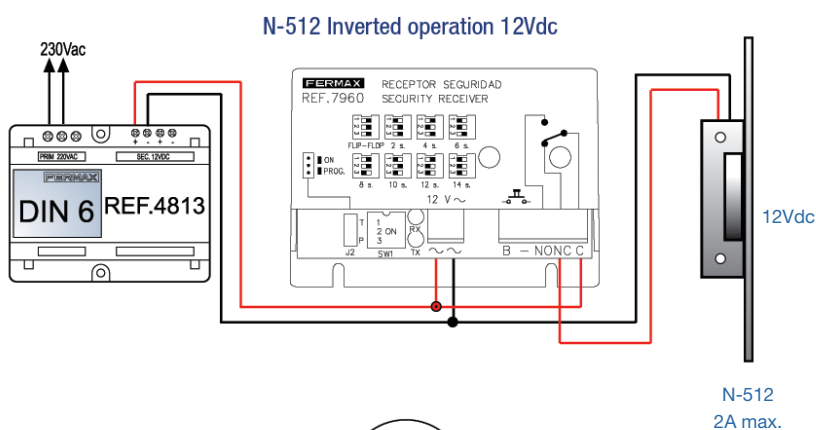

Flip-flop receiver configuration. Each pressing of the emitter will open or close the door.



Remote control Ref.24651 emitter

NOTE: Normal operation door release 12Vac, Ref.3071. Inverted operation door release 12Vdc, Ref.2967. This receiver requires remote controls Ref.24651.

REMOTE CONTROL OPENING. RECEIVER REF.7903

OPENING OF A NORMAL OPERATION
DOOR RELEASE 12Vac

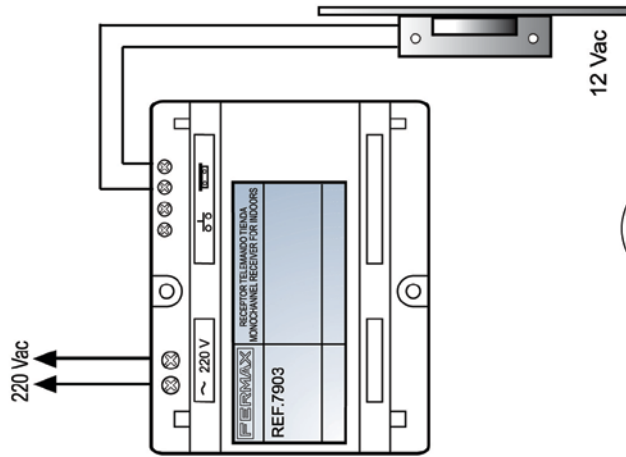

12 Vac

ACTIVATION OF AN AUXILIARY RELAY
TO ACTIVATE GARAGE DOOR

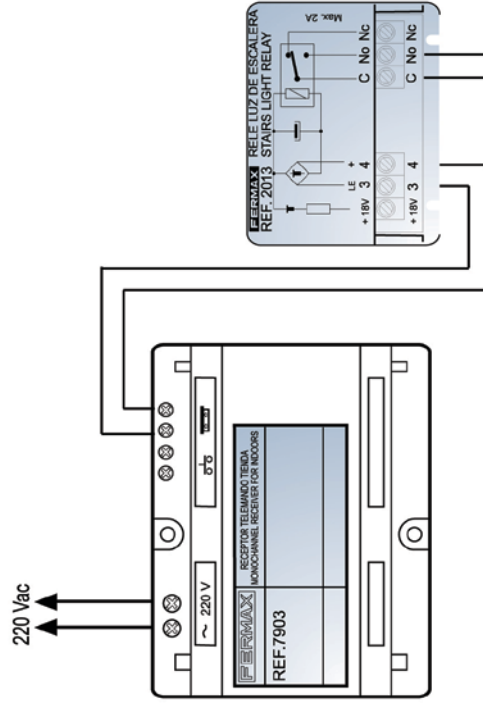

Connect to the dry
contact input of the
motor/gate.

CONFIGURATION

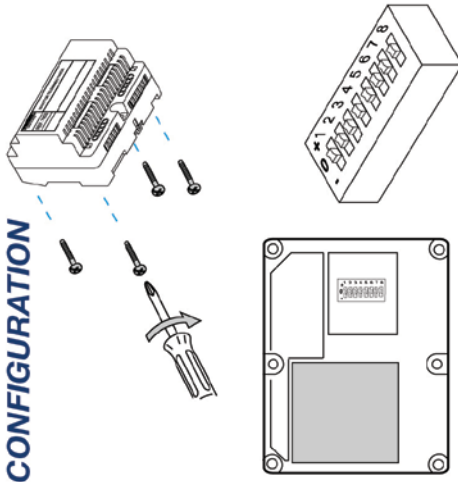

NOTE: Access the inside of the ref.7903 to configure the microswitches the same way as the emitter.

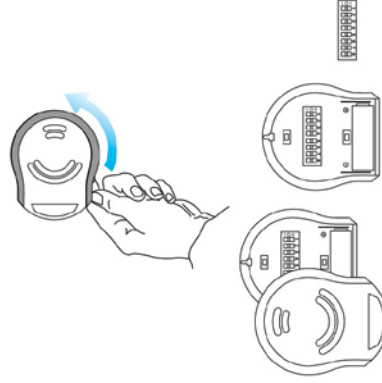

Requires emitter ref.79561.

NOTE: When the emitter 79561 is activated the receiver 7903 will supply a voltage of 12 Vac during a few seconds.

REMOTE CONTROL OPENING. RECEIVER REF.7952

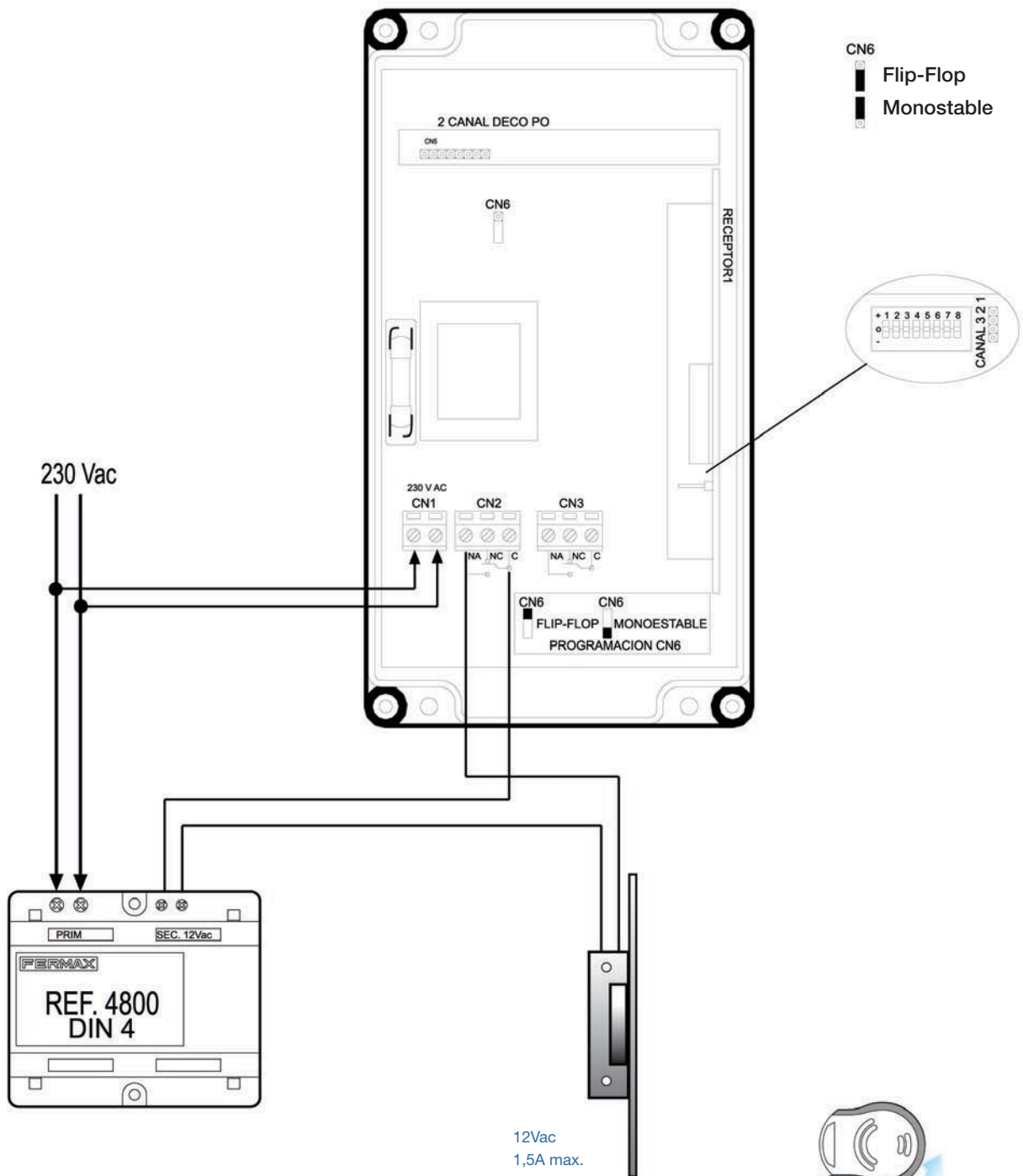

Monostable: By activating the remote control, the relay is activated during a few seconds turning back to stand-by position after a few seconds.
 Flip-Flop: With each pressing of the remote control the relay is activated or deactivated. Allows the connection of the second channel card ref.7934.
 This receiver requires remote control ref.79561 Dual channel emitter.

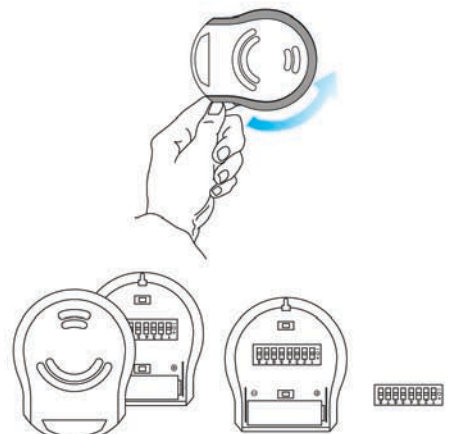

REF.	DESCRIPTION	PAGE
1076	MAGNETIC CONTACT	48
2013	RELAY 12Vac/12Vdc 2A	49
2060	EMERGENCY BATTERY ADAPTOR 12VDC	47
2070	BATTERY 12V/2,2A ACID LEAD	47
2306	PROGRAMMING KEYPAD	54
2336	PROXIMITY CARD WITH MAGNETIC STRIP	54
2337	BATTERY 12V/7A ACID LEAD	47
2796	LOCK RELEASE MOD.500ND-412-MX	20
2797	LOCK RELEASE MOD.500A-412-MX	20
2798	LOCK RELEASE MOD.500AD-412-MX	20
2799	LOCK RELEASE MOD.500N-512-MX	20
2802	LOCK RELEASE MOD.410N-L22-MAX	18
2803	LOCK RELEASE MOD.410ND-L22-MAX	18
2804	LOCK RELEASE MOD.410A-L22-MAX	18
2805	LOCK RELEASE MOD.410AD-L22-MAX	18
2806	LOCK RELEASE MOD.410ND-412-P22-MAX	18
2807	LOCK RELEASE MOD.410AD-412-P22-MAX	18
2808	LOCK RELEASE MOD.410N-512-P22-MAX	18
2809	LOCK RELEASE MOD.410N-412-L22-MAX	18
2810	LOCK RELEASE MOD.410ND-412-L22-MAX	18
2811	LOCK RELEASE MOD.410A-412-L22-MAX	18
2812	LOCK RELEASE MOD.410AD-412-L22-MAX	18
2813	LOCK RELEASE MOD.410N-512-L22-MAX	18
2814	UNIVERSAL LOCK RELEASE MOD.450A-412-M	16
2815	UNIVERSAL LOCK RELEASE MOD.450Aa-S	16
2816	UNIVERSAL LOCK RELEASE MOD.450AD-412-M	16
2817	UNIVERSAL LOCK RELEASE MOD.450Aa-412-S	16
2818	UNIVERSAL LOCK RELEASE MOD.450AD-M	16
2819	UNIVERSAL LOCK RELEASE MOD.450AaD-412-S	16
2820	UNIVERSAL LOCK RELEASE MOD.450AD-S	16
2821	UNIVERSAL LOCK RELEASE MOD.450AaD-S	16
2822	UNIVERSAL LOCK RELEASE MOD.450A-M	16
2824	UNIVERSAL LOCK RELEASE MOD.450N-412-M	16
2826	UNIVERSAL LOCK RELEASE MOD.450N-512-M	16
2828	UNIVERSAL LOCK RELEASE MOD.450N-512-S	16
2830	UNIVERSAL LOCK RELEASE MOD.450ND-412-M	16
2832	UNIVERSAL LOCK RELEASE MOD.450ND-M	16
2834	UNIVERSAL LOCK RELEASE MOD.450ND-S	16
2836	UNIVERSAL LOCK RELEASE MOD.450N-M	16
2838	GX-TYPE SHIELD	45
2868	MX-TYPE SHIELD	45
2869	MECHANISM MOD.850A	26
2870	LOCK RELEASE MOD.520N-PX	22
2871	LOCK RELEASE MOD.520A-PX	22
2872	LOCK RELEASE MOD.520N-412-PX	22
2873	LOCK RELEASE MOD.520N-512-PX	22
2874	LOCK RELEASE MOD.620N-SX	21
2875	LOCK RELEASE MOD.620Aa-SX	21
2876	LOCK RELEASE MOD.620N-GX	21
2877	LOCK RELEASE MOD.620Aa-GX	21
2878	ELECTRIC RIM LOCK MOD.961-DOUBLE KEY	38
2879	ELECTRIC RIM LOCK MOD.962-DOUBLE KEY+PUSHBUTTON	38
2880	LOCK RELEASE MOD.500N-SX	20
2881	LOCK RELEASE MOD.500ND-SX	20

REF.	DESCRIPTION	PAGE
2882	LOCK RELEASE MOD.500A-SX	20
2883	LOCK RELEASE MOD.500AD-SX	20
2884	LOCK RELEASE MOD.500N-MX	20
2885	LOCK RELEASE MOD.500ND-MX	20
2886	LOCK RELEASE MOD.500A-MX	20
2887	LOCK RELEASE MOD.500AD-MX	20
2888	LOCK RELEASE MOD.500N-412-SX	20
2889	LOCK RELEASE MOD.410N-412-P22-MAX	18
2890	LOCK RELEASE MOD.410A-412-P22-MAX	18
2891	B22-TYPE GREY SHIELD	44
2892	L22-TYPE GREY SHIELD	45
2893	M-TYPE SHIELD	45
2894	P22-TYPE GREY SHIELD	44
2895	T-TYPE GREY SHIELD	45
2897	FLOOR RETAINING MAGNET 24VDC/50 Kg	47
2899	WALL RETAINING MAGNET 2 INPUT 24VDC/50 Kg	47
2907	UNIVERSAL LOCK RELEASE AD-424-S	17
2908	UNIVERSAL LOCK RELEASE A-424-S	17
2909	UNIVERSAL LOCK RELEASE A-S	17
2910	UNIVERSAL LOCK RELEASE AD-S	17
2911	UNIVERSAL LOCK RELEASE N-S	17
2912	UNIVERSAL LOCK RELEASE ND-S	17
2913	DOOR CONTACT 2C (DOUBLE)	48
2917	LOCK RELEASE A-2001 CHROME	29
2922	DOOR CONTACT 3C (TRIPLE)	48
2923	LOCK RELEASE N-2001 CHROME	29
2924	UNIVERSAL LOCK RELEASE N-G	17
2925	UNIVERSAL LOCK RELEASE ND-G	17
2926	UNIVERSAL LOCK RELEASE A-G	17
2927	UNIVERSAL LOCK RELEASE AD-G	17
2940	LOCK RELEASE N-2003 AL.ANOD	31
2942	LOCK RELEASE A-2003 AL.ANOD	31
2948	LOCK RELEASE N-2005 CHROME	30
2950	LOCK RELEASE A-2005 CHROME	30
2952	LOCK RELEASE N-2007 GREY	30
2953	LOCK RELEASE MOD.3000N-S	19
2954	LOCK RELEASE A-2007 GREY	30
2956	LOCK RELEASE MOD.460N BISEL	23
2958	UNIVERSAL LOCK RELEASE N-412-S	17
2961	CRYSTAL LOCK RELEASE MOD.CA CHROME	40
2962	UNIVERSAL LOCK RELEASE N-424-S	17
2964	2007-TYPE GREY CASE	46
2967	UNIVERSAL LOCK RELEASE N-512-S	17
2968	UNIVERSAL LOCK RELEASE N-524-S	17
2969	LOCK RELEASE MOD.9000N GREY	25
2971	LOCK RELEASE MOD.9000Aa GREY	25
2973	S-TYPE SHIELD	44
2974	P-TYPE GREY SHIELD	44
2975	G-TYPE GREY SHIELD	45
2976	1001-TYPE BROWN SHIELD. LEFT DIN	45
2977	1002-TYPE BROWN SHIELD. RIGHT DIN	45
2979	2001-TYPE CHROME CASE	46
2981	2003-TYPE GREY COVER/CASE	46
2983	2005-TYPE CHROME CASE	46
2984	LOCK RELEASE MOD.8000N WITH CHAIN	39

REF.	DESCRIPTION	PAGE
2985	GE-TYPE SHIELD	45
2987	2006-TYPE GREY CASE	46
2989	LOCK RELEASE MOD.NGB	32
2991	ELECTRIC RIM LOCK MOD.932 W/KEY+PUSHBUTT.	37
2996	CRYSTAL LOCK RELEASE MOD.CN CHROME	40
2997	CRYSTAL LOCK RELEASE MOD.CND CHROME	40
2998	CRYSTAL LOCK RELEASE MOD.CAD CHROME	40
3000	LOCK RELEASE N-2006 GREY	29
3002	LOCK RELEASE A-2006 GREY	29
3004	LOCK RELEASE MOD.6000N	33
3005	LOCK RELEASE MOD.6000A	33
3006	LOCK RELEASE MOD.6000AD	33
3007	ELECTRIC RIM LOCK MOD.931 DOUBLE KEY	37
3027	LOCK RELEASE MOD.470N	24
3028	LOCK RELEASE MOD.470N-412	24
3029	LOCK RELEASE MOD.470N-512	24
3030	LOCK RELEASE MOD.480N	34
3031	LOCK RELEASE MOD.480Aa	34
3032	LOCK RELEASE MOD.480N-412	34
3033	LOCK RELEASE MOD.480N-512	34
3034	LOCK RELEASE MOD.490N	35
3035	LOCK RELEASE MOD.490Aa	35
3036	LOCK RELEASE MOD.490N-412	35
3037	LOCK RELEASE MOD.490N-512	35
3038	UNIVERSAL LOCK RELEASE A-412-S	17
3039	UNIVERSAL LOCK RELEASE N-412-G	17
3040	LOCK RELEASE MOD.410N-P22-MAX	18
3041	LOCK RELEASE MOD.410ND-P22-MAX	18
3042	ELECTRIC RIM LOCK MOD.933 W/KEY-NO PUSHBUTTON FUNCTION	37
3048	LOCK RELEASE MOD.410A-P22-MAX	18
3049	SX-TYPE SHIELD	44
3050	ELECTROMAGNETIC LOCK RELEASE FLUSH-MOUNTED 300KG	28
3051	SURFACE ELECTROMAGNETIC LOCK 500Kg	41
3052	SURFACE ELECTROMAGNETIC LOCK 300KG	41
3057	UNIVERSAL LOCK RELEASE MOD.450A-412-S	16
3058	UNIVERSAL LOCK RELEASE MOD.450AD-412-S	16
3059	UNIVERSAL LOCK RELEASE MOD.450ND-412-S	16
3061	LOCK RELEASE MOD.460N-412	23
3062	LOCK RELEASE MOD.460N-512	23
3063	LOCK RELEASE MOD.9000N-412 GREY	25
3064	LOCK RELEASE MOD.PN (panic)	36
3065	LOCK RELEASE MOD.PN-412 (panic)	36
3066	LOCK RELEASE MOD.PN-512 (panic)	36
3067	LOCK RELEASE MOD.PN-424 (panic)	36
3068	LOCK RELEASE MOD.410AD-P22-MAX	18
3069	UNIVERSAL LOCK RELEASE MOD.450A-S	16
3070	UNIVERSAL LOCK RELEASE MOD.450N-412-S	16
3071	UNIVERSAL LOCK RELEASE MOD.450N-S	16
3072	LOCK RELEASE MOD.6000N-412	33
3073	LOCK RELEASE MOD.6000N-512	33
3074	LOCK RELEASE MOD.NGB-412	32
3075	LOCK RELEASE MOD.NGB-512	32
3077	BRACKET L-2 FOR REF.3051	41
3078	BRACKET L-3 FOR REF.3052	41

REF.	DESCRIPTION	PAGE
3079	Z BRACKET DOUBLE	41
3082	DOOR CONTACT 4C (MONITORED DEADBOLT)	48
3083	FLEXIBLE CONDUIT	49
3084	RIGID VANDAL PROOF CONDUIT	49
3088	L-TYPE GREY SHIELD	45
3089	53-TYPE GREY SHIELD	44
3093	UNIVERSAL LOCK RELEASE AD-412-S	17
3094	CRYSTAL LOCK RELEASE MOD.CIA-SX INOX	27
3095	CRYSTAL LOCK RELEASE MOD.CIIN-SX INOX	27
3096	CRYSTAL LOCK RELEASE MOD.CIIN-412-SX INOX	27
3098	CRYSTAL LOCK RELEASE MOD.CIIN-512-SX INOX	27
3101	AUTOMATIC LOCK MOD.850/50A	26
3102	AUTOMATIC LOCK MOD.850/25A	26
3103	AUTOMATIC LOCK MOD.850/35A	26
3104	AUTOMATIC LOCK MOD.850/30A	26
3105	LOCK RELEASE MOD.500ND-412-SX	20
3106	LOCK RELEASE MOD.500A-412-SX	20
3107	LOCK RELEASE MOD.500AD-412-SX	20
3108	LOCK RELEASE MOD.500N-512-SX	20
3109	LOCK RELEASE MOD.500N-412-MX	20
3264	ELECTRIC LOCK COMMANDER VAC	47
3491	RELAY DIN 12VDC (220VAC/12A)	49
4800	POWER SUPPLY 12VAC/1,5A	47
4813	POWER SUPPLY 12VDC/2A	47
6991	CITYLINE MEMOKEY READER	53
6992	CITYLINE PROXIMITY READER	54
7061	SURFACE BOX S-1	53
7900	COMPATIBLE SINGLE-CHANNEL RECEIVER	52
7903	RF RECEIVER SHOPS/STORES	52
7934	SECOND-CHANNEL CARD	52
7952	SINGLE-CHANNEL RECEIVER 433MHZ	52
7960	SECURITY RECEIVER	52
8948	FLUSH BOX S-1	53,54
23361	PROXIMITY CARD WITHOUT MAGNETIC STRIP	54
24651	DIGITAL EMITTER	52
24661	READER-PC INTERFACE	54
28148	UNIVERSAL LOCK RELEASE MOD.450A-412-M MAX	16
28168	UNIVERSAL LOCK RELEASE MOD.450AD-412-M MAX	16
28188	UNIVERSAL LOCK RELEASE MOD.450AD-M MAX	16
28208	UNIVERSAL LOCK RELEASE MOD.450AD-S MAX	16
28228	UNIVERSAL LOCK RELEASE MOD.450A-M MAX	16
28248	UNIVERSAL LOCK RELEASE MOD.450N-412-M MAX	16
28268	UNIVERSAL LOCK RELEASE MOD.450N-512-M MAX	16
28288	UNIVERSAL LOCK RELEASE MOD.450N-512-S MAX	16
28308	UNIVERSAL LOCK RELEASE MOD.450ND-412-M MAX	16
28328	UNIVERSAL LOCK RELEASE MOD.450ND-M MAX	16
28348	UNIVERSAL LOCK RELEASE MOD.450ND-S MAX	16
28368	UNIVERSAL LOCK RELEASE MOD.450N-M MAX	16
29001	TIMMER	49
29078	UNIVERSAL LOCK RELEASE AD-424-S MAX	17
29088	UNIVERSAL LOCK RELEASE A-424-S MAX	17
29098	UNIVERSAL LOCK RELEASE A-S MAX	17
29108	UNIVERSAL LOCK RELEASE AD-S MAX	17
29118	UNIVERSAL LOCK RELEASE N-S MAX	17

REF.	DESCRIPTION	PAGE
29128	UNIVERSAL LOCK RELEASE ND-S MAX	17
29178	LOCK RELEASE A-2001 CHROME MAX	29
29238	LOCK RELEASE N-2001 CHROME MAX	29
29248	UNIVERSAL LOCK RELEASE N-G MAX	17
29258	UNIVERSAL LOCK RELEASE ND-G MAX	17
29268	UNIVERSAL LOCK RELEASE A-G MAX	17
29278	UNIVERSAL LOCK RELEASE AD-G MAX	17
29408	LOCK RELEASE N-2003 AL.ANOD MAX	31
29428	LOCK RELEASE A-2003 AL.ANOD MAX	31
29488	LOCK RELEASE N-2005 CHROME MAX	30
29508	LOCK RELEASE A-2005 CHROME MAX	30
29528	LOCK RELEASE N-2007 GREY MAX	30
29548	LOCK RELEASE A-2007 GREY MAX	30
29580	LOCK RELEASE MOD.3000N-412-S	19
29588	UNIVERSAL LOCK RELEASE N-412-S MAX	17
29620	LOCK RELEASE MOD.3000N-424-S	19
29628	UNIVERSAL LOCK RELEASE N-424-S MAX	17
29670	LOCK RELEASE MOD.3000N-512-S	19
29678	UNIVERSAL LOCK RELEASE N-512 MAX	17
29680	LOCK RELEASE MOD.3000N-524-S	19
29688	UNIVERSAL LOCK RELEASE N-524-S MAX	17
30008	LOCK RELEASE N-2006 GREY MAX	29
30028	LOCK RELEASE A-2006 GREY MAX	29
30388	UNIVERSAL LOCK RELEASE A-412-S MAX	17
30398	UNIVERSAL LOCK RELEASE N-412-G MAX	17
30578	UNIVERSAL LOCK RELEASE MOD.450A-412-S MAX	16
30588	UNIVERSAL LOCK RELEASE MOD.450AD-412-S MAX	16
30598	UNIVERSAL LOCK RELEASE MOD.450ND-412-S MAX	16
30698	UNIVERSAL LOCK RELEASE MOD.450A-S MAX	16
30708	UNIVERSAL LOCK RELEASE MOD.450N-412 S MAX	16
30718	UNIVERSAL LOCK RELEASE MOD.450N-S MAX	16
30938	UNIVERSAL LOCK RELEASE AD-412-S MAX	17
44501	PROXIMITY KEYRING	54
79561	DUAL-CHANNEL EMITTER 433MHZ TRINARY	52
88101	RELAY 18VDC DOUBLE CONTACT	49

DESIGN

Fermax Electrónica S.A.U.

DOOR LOCK RELEASE

1st Edition. February 2012

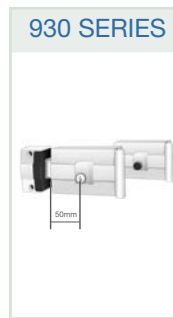

FERMAX

Audio and Video Door Entry Systems

www.fermax.com doorlock@fermax.com