



Ditec DAB105

Smart automation
to make your life easier

EN

VERS ATILE

Performance

Powerful and compact operator capable of satisfying the needs of high traffic doors, and also special requirements for emergency exits and fire doors, in complete compliance with most of European regulations.

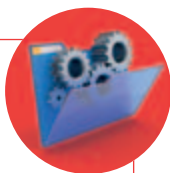

Convenient & flexible

Modern buildings require applications that are flexible and adaptable to any need: Ditec DAB105 meets these requirements. The upgrade cards offer additional features and advanced functions, which allow to customise the automation.

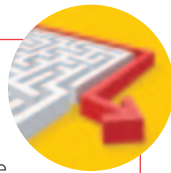

Safe & reliable

Safe and convenient access without barriers, in compliance with the strict requirements of public sector, also thanks to its Low Energy mode. In addition, Ditec DAB105 can be activated through buttons, sensors or the PUSH&GO function.

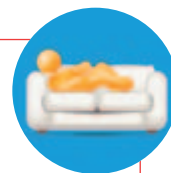

Ditec DAB105



Ditec DAB105 ensures access without barriers and ease of operation

Discover the features that make it unique

Performance

- High performance with up to 90 kg door weight and mechanic servo-assisted operator, encoder controlled
- Reliable operator: strong components and real time self monitoring of the operator status
- Safety guaranteed by technological features, SOS alert system when opening, motion detection safety signal
- Very low noise level
- Many additional advanced features make Ditec DAB105 a best in class product

Convenient & flexible

- Easy to install, to set, and to maintain: available PUSH or PULL configurations
- Easy program selection to expand functions (with a card) if necessary
- One operator matches specific installation requirements (double leaf doors, installations in presence of wind, key controlled access)
- Easy to order: 1 item alone includes operator + cover (just add arm)
- Power assisted: the entire opening operation is carried out by low, motor assisted power making it an ideal solution for users with or without disabilities.

Safe & reliable

- Several operating modes to match different demands (PUSH&GO, power assist, key impulse)
- Low Energy mode and battery kit available
- Convenient operator control via sensors, switch, program and key selectors
- Fire tested version (SP SITAC tested)

Main features

Max performances	90 kg x 1.2 m
Automation for swing doors	motor opening, spring and motor closing
Service index	5 - heavy duty
Lifecycle	1,000,000 cycles
Protection level	IP 20
Operating temperature	-20°C / +45°C
Opening time	3 ÷ 6 0°-80°
Closing time	3 ÷ 6 90°-10°
Hold open time	1.5 ÷ 30 s
Product dimensions (mm)	111x131x720



Main components

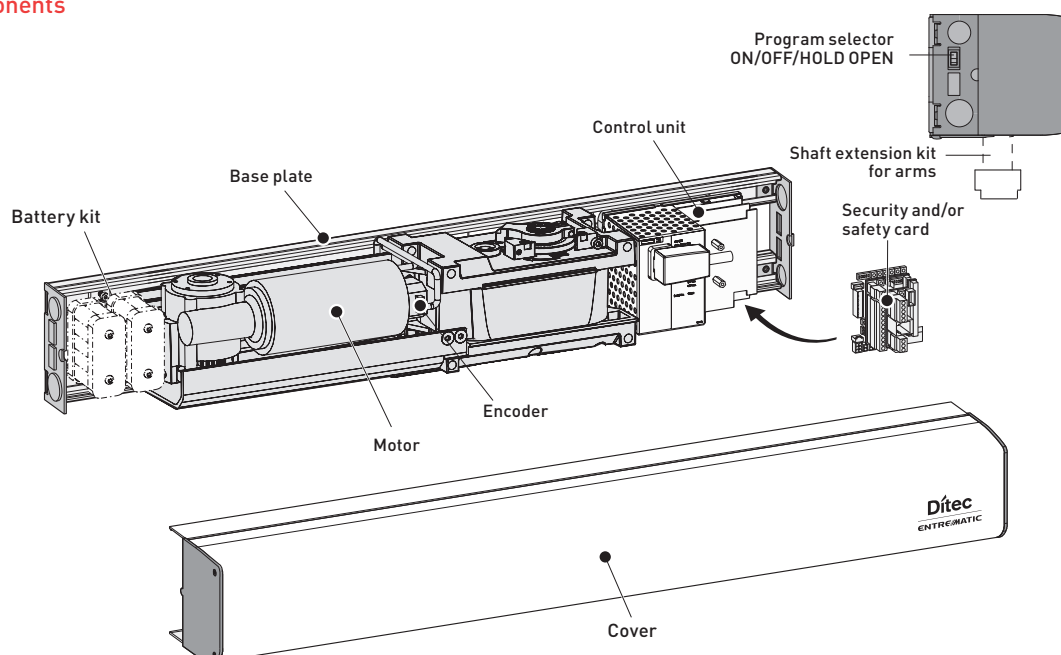

Accessories

Movement arms

DAB805PSA –PSAF

Arm with articulated motion.



DAB805PLAT

Arm with three-sections articulated motion for doors that open inward; automation seen from the side.



DAB805PLA –PLAB

Arm with sliding motion. PLAB is for anti-panic breakout systems.

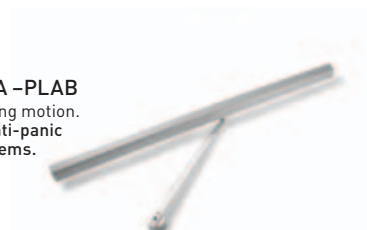

Articulated - DAB805PSA –PSAF

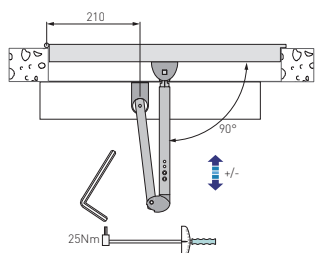

Articulated in three sections - DAB805PLAT

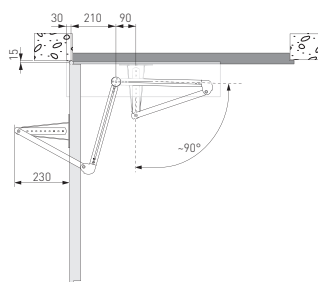

Sliding - DAB805PLA

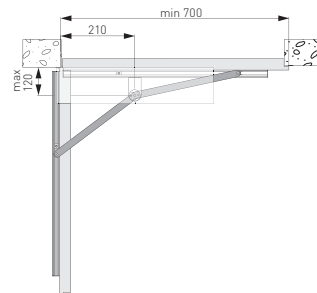

Specific accessories

- DAB905BAT: battery kit
- COM400MHB: mechanical switch program selector
- COM400MKB: mechanical key program selector

Control accessories and sensors

The automation can be completed with Ditec command, control and safety devices.

To select appropriate items, please refer to the PM general price list.

Certifications

MD Machine Directive	EMCD Compatibility Directive Electromagnetic	LVD Low Voltage Directive	EN 16005 User Safety Standard	FIRED TESTED SP SITAC
--------------------------------	---	-------------------------------------	---	---------------------------------

When building the system, only use Ditec accessories and safety devices.

Every Ditec automation features CE marking and is designed and built in compliance with the safety requirements of the Machinery Directive (2006/42/EC), of the Electromagnetic Compatibility Directive (2004/108/EC) and of the Low Voltage Directive (2006/95/EC) and of other Directives, laws, specific standards for special products and situations.

The Company reserves the right to make changes which may improve the products.

For this reason, the technical details featured in this catalogue are not binding.

The pictures shown in this leaflet were taken with the consent of those concerned or in public locations.

Further information can be found in the Technical Manuals available at the website: www.ditecentrematic.com

Ditec
ENTRE//MATIC



Entrematic

Via Mons. Banfi, 3 • 21042 Caronno P.lla (VA) • Italy

Tel +39 02 963911 • Fax: +39 02 9650314

ditec@entrematic.com

www.ditecentrematic.com • www.entrematic.com

Cod. P203B - 11/2013
Ditec DAB105

gdp milano 148965

Ditec Entrematic branches are in: Belgium, France, Germany, Portugal, Spain, Sweden, Switzerland, Turkey, Latin America, USA, Canada and China.

For addresses and contacts visit our website www.ditecentrematic.com

