

Deadlocking Bolt

DB25 & DB25KO - Instructions

Read all instructions before starting installation

Installation

1 FITTING AND ALIGNMENT

The bolt can be installed in a vertical or horizontal position fitted into the frame or door leaf

Ensure that

The circular magnet on the strike plate lines up with the (M) on the bolt faceplate

The hole behind the strike plate is deep enough and clear of debris to take the full throw of the bolt

The bolt does not rub or catch while in motion as it may not lock / unlock

DO NOT - Fit bolt in floor firing upwards

2 POWER SUPPLY

Ensure that

2 amp PSU is used per bolt

Place the PSU as near as possible to the bolt

DO NOT - use AC transformer and rectifier due to power loss

3 CABLE

Ensure that

Connections are made with stranded alarm cable
Allow extra cores to double/treble the cable should reduced voltage occur at bolt because of distance from bolt to PSU

DO NOT - use solid telephone cabling for connections

4 CONTROLLING THE BOLT

There is a preferred 3 wire full function, and a reduced 2 wire function. Features are opposite, full wiring details are overleaf.

3 Wire function requires permanent power to the bolt, and a positive pulse across the control terminal (2) to operate the bolt.

2 Wire function operates in a similar way to a normal electric locking device. Using 2 wire function loses the benefit of the built-in access control functions of 3 wire set-up.

**SEE BACK PAGE FOR
DB25KO INSTRUCTIONS**

Features	3 Wire Function	2 Wire Function
Multiple Unlock (PTO only)	✓ 5x	✗
8 Second Unlock	✓	✗
Anti-Tailgate	✓	✗
Auto-Relock	✓	✓
Multiple Re-Lock (PTL only)	✓ 9x	✓ 5x
Electrical Override	✓	✗
Anti Tamper	✓	✓

Current Draw	Activating Current	Holding Current (After 200ms)
12v DC	1050mA	210mA
13.8v DC	1220mA	185mA
24v DC	900mA	80mA
27.6v DC	1000mA	75mA

Terminal Connections

The DB25 has a multiple voltage input from 12vDC -10% to 24vDC +15%

Built-in transient and reverse polarity protection

1	+	Positive Power Input	
2	C	Control Wire (Do Not Confuse With Common)	
3	-	Negative Power Input	
4	NO	Door Position Switch	- Normally Open
5	C	Door Position Switch	- Common
6	C	Bolt Position Switch	- Common
7	NO	Bolt Position Switch	- Normally Open
8	NC	Bolt Position Switch	- Normally Closed

Carefully remove black casing to access the Jumper pins

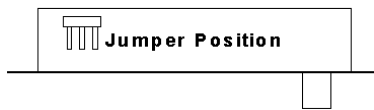

	3 Wire Mode	2 Wire Mode
Fail Secure (PTO)		
Fail Open (PTL)		

alpro® *First Choice for Locking Solutions*

T 01202 676262 F 01202 680101 E info@alpro.co.uk W www.alpro.co.uk

Deadlocking Bolt

DB25 & DB25KO - Instructions

3 Wire Function

Fail Open (PTL) or Fail Secure (PTO)

Connections

This method will require a permanent power feed across terminals 1 & 3.

Operation

After the initial 8 seconds when the bolt is first powered up, the bolt will lock (Fail Open - PTL) or stay locked (Fail Secure - PTO) as long as the door is closed with the strike plate correctly aligned.

A short pulse between terminals 1 & 2 will unlock the bolt. The bolt will lock as soon as the door is closed. If the door is not opened the bolt will relock after 8 seconds.

Apply a pulse between terminals 1 & 2 of longer than 8 seconds and the bolt will relock as soon as the pulse times out and the door is closed.

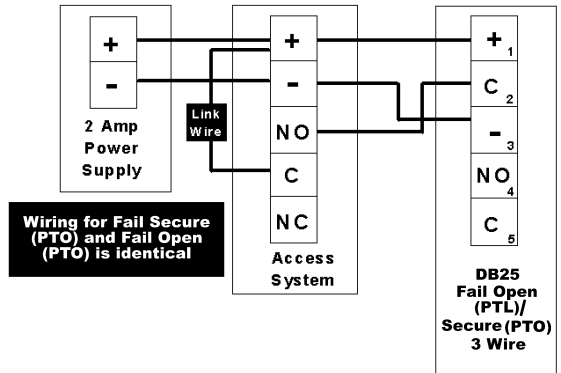
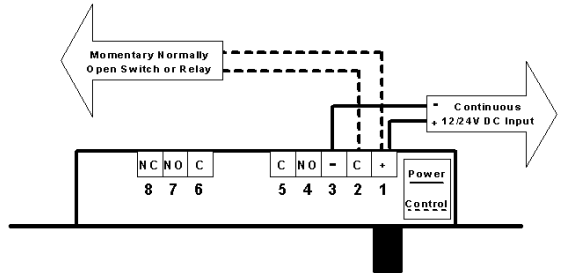

Monitoring Connections

The DB25 has dual monitoring as standard.

Door Position Switch (DPS) - Terminals 4 & 5 has a maximum rating of 100v AC/DC @ 300mA

Bolt Position Switch (BPS) - Terminals 6, 7 & 8 has a maximum rating of 125v AC @ 3A, 30v DC @ 500mA

DPS is triggered by the circular magnet on the strike plate lining up correctly with the 'M' on the bolt faceplate.

NB. If you connect the fail open (PTL) bolt using the 2 wire method you lose the DPS as it has been used to control the bolt.

BPS is triggered by the bolt engaging fully in the locked or unlocked position.

Lubrication

This product is lubricated for life.

Additional lubrication of any kind voids our warranty.

Deadlocking Bolt

DB25 & DB25KO - Instructions

2 Wire Function

Fail Open (PTL)

Connections

This method will require a switched on/off power feed across terminals 1 & 3

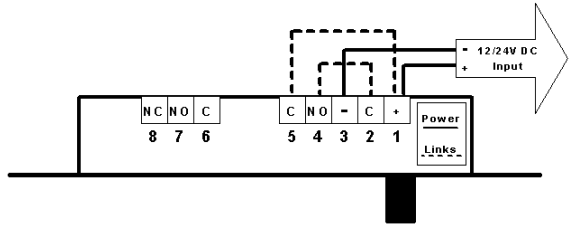

Operation

This bolt will be unlocked without power applied and will lock when the correct voltage is applied as long as the door is closed with the strike plate correctly aligned.

Jumper

Move the internal jumper for 2 wire (fail open/PTL) configuration, as shown on page 1.

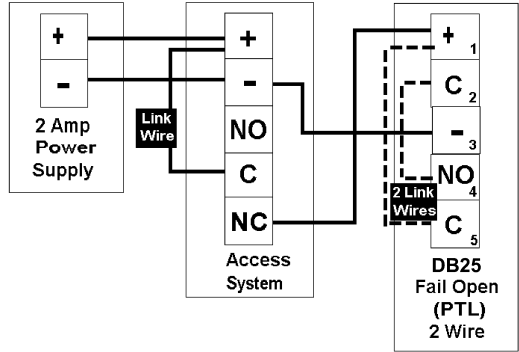

2 Wire Function

Fail Secure (PTO)

Connections

This method will require a switched on/off power feed across terminals 1 & 3

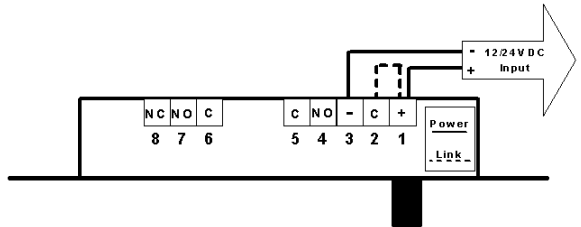

Operation

This bolt will be locked without power applied and will unlock when the correct voltage is applied. When the power is removed the bolt will lock regardless of the door position, the application of this configuration should be used with caution.

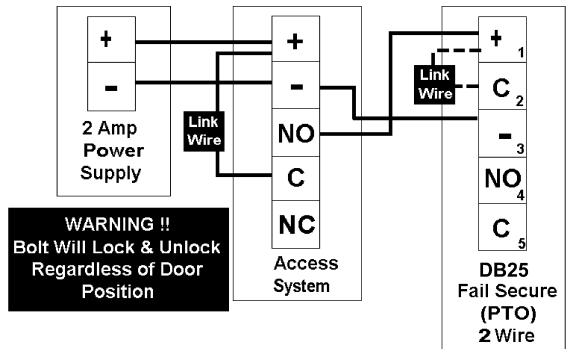

Deadlocking Bolt

DB25 & DB25KO - Instructions

KEY OVERRIDE INSTRUCTIONS

Fail Locked Secure (PTO)

Key override is a mechanical operation with no additional wiring. This can be used in either the 2 or 3 wire modes.

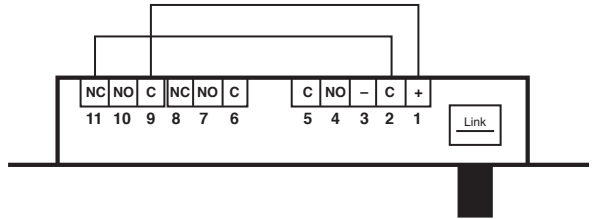

Fail Unlocked Open (PTL)

Key override is an electrical operation using the additional wiring as shown opposite. This can only be achieved in the 3 wire mode.

Above links are additional to connections shown earlier in the instructions. They are only required for Fail Open (PTL) bolts in 3 wire mode.

- 1 - (+) Positive Power Input
- 2 - (C*) Control Wire (Do not confuse with Common)
- 3 - (-) Negative Power Input
- 4 - (NO) Door Position Switch - Normally Open
- 5 - (C) Door Position Switch - Common
- 6 - (C) Bolt Position Switch - Common
- 7 - (NO) Bolt Position Switch - Normally Open
- 8 - (NC) Bolt Position Switch - Normally Closed
- 9 - (C) Key Override Switch - Common
- 10 - (NO) Key Override Switch - Normally Open
- 11 - (NC) Key Override Switch - Normally Closed

EURO PROFILE CYLINDER OPTIONS (Not supplied)

Single cylinder (Key can project from either side).

Cylinder & Turn (Key Outside, Thumbturn Inside).

Double cylinder (Key both sides).

