

CABLE SIZE GUIDE

All cable sizes in this chart are measured in mm² for the cable diameters and meters for the cable distances. For convenience we have included a conversion chart from AWG (American Wire Gauge) to mm².

AWG	CSA mm ²
8	8.35 mm ²
9	6.62 mm ²
10	5.27 mm ²
11	4.15 mm ²
12	3.31 mm ²
13	2.63 mm ²
14	2.08 mm ²
15	1.65 mm ²
16	1.31 mm ²
17	1.04 mm ²
18	0.823 mm ²
19	0.653 mm ²
20	0.519 mm ²
21	0.412 mm ²
22	0.325 mm ²
23	0.259 mm ²
24	0.205 mm ²

In certain applications it will be necessary to use a twisted pair cable for certain pairs of connections between devices or even a screened cable. This will be indicated in the chart.

A popular cable type to use would be CW1308 or an equivalent. CW1308 is a twisted pair telephone cable readily available in a selection or pair quantities with a core size of 0.19mm². In the charts below, cables sizes greater than 0.19mm² will require either a larger core size or double up on cores for one connection. Which ever option is chosen, it will still be necessary to follow the requirements for either screened cable or the use of twisted pairs where indicated.

CORE QUANTITY GUIDE FOR AUDIO TELEPHONES

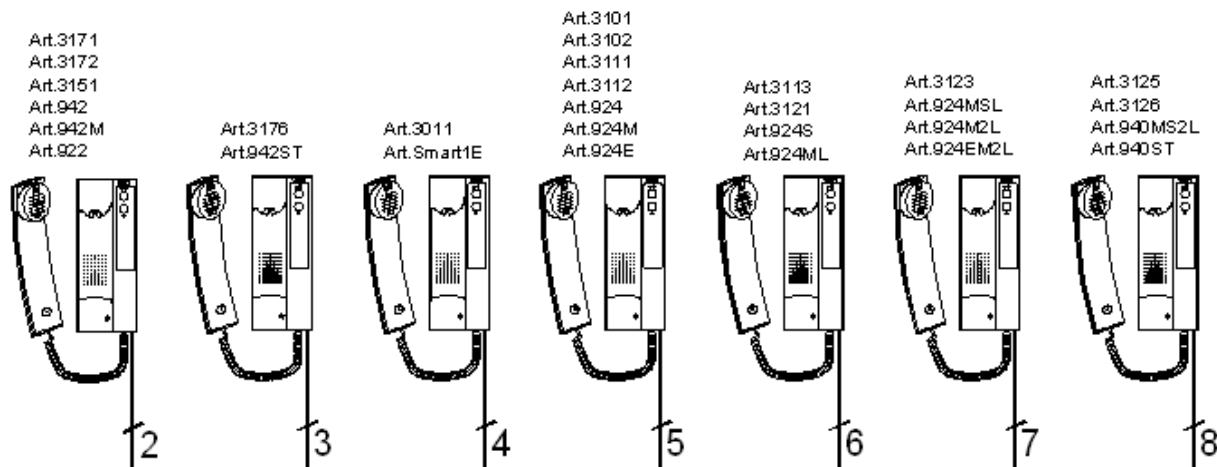

CORE QUANTITY GUIDE FOR VIDEOPHONES

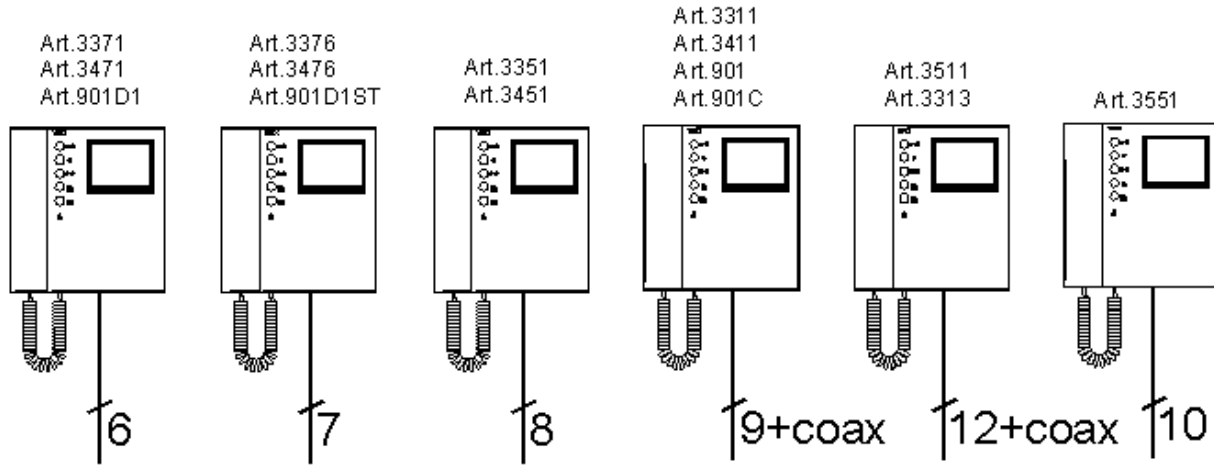

VPROX proximity systems:

Reader connections

Connections	50m	100m	200m
+12	0.25mm ²	0.5mm ²	0.75mm ²
Gnd	0.25mm ²	0.5mm ²	0.75mm ²
RK	0.25mm ²	0.5mm ²	0.75mm ²
LG	0.25mm ²	0.5mm ²	0.75mm ²
LR	0.25mm ²	0.5mm ²	0.75mm ²

For best performance RK & Gnd should be a twisted pair.
 Maximum acceptable resistance for all terminals = 10Ω.
 Maximum overall distance between reader and CPU = 200m



Reader part numbers

- VP/PM (4X)
- 849S (70X)
- 849PG (76X/G)
- 849PW (76X/W)
- 949SB (70X/S)
- 949SP (70X/S/G)
- 849FS (72X)
- 849SS (72X/S)

VP1000 & VP4000 bus connections

Connections	50m	100m	200m	300m	400m	500m	600m
Gnd	0.25mm ²	0.5mm ²	0.75mm ²	1.0mm ²	1.5mm ²	2.0mm ²	2.5mm ²
CK	0.25mm ²	0.5mm ²	0.5mm ²	0.75mm ²	1.0mm ²	1.5mm ²	2.0mm ²
DA	0.25mm ²	0.5mm ²	0.5mm ²	0.75mm ²	1.0mm ²	1.5mm ²	2.0mm ²

CK & Gnd must be a twisted pair and DA & Gnd must be a twisted pair.
 Maximum acceptable resistance for all terminals = 10Ω.
 A screened cable should be used on these connections. The screen should be earthed at one end only.

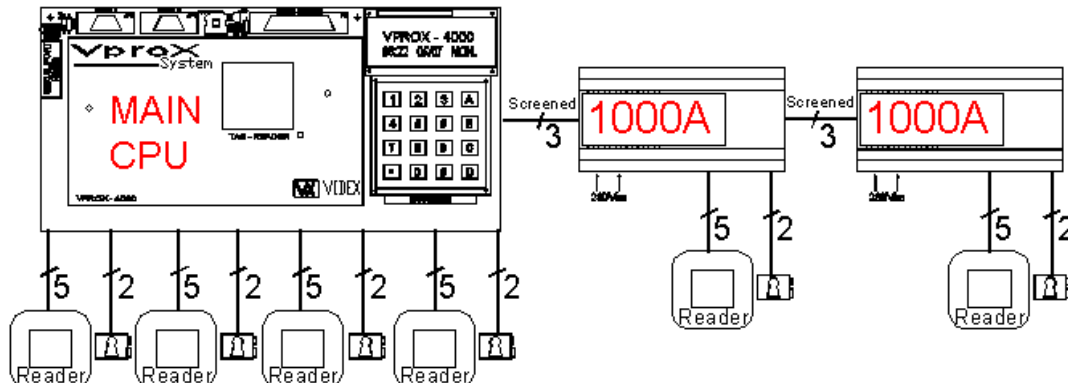

Connections for power supply output and lock release.

	50m	100m
Connections	0.5mm ²	0.75mm ²

The power supply should be located as close to the door panel as possible for best performance.
 Maximum acceptable resistance for above cables = 3Ω

O2LA proximity access systems:

Reader connections:

- The readers can be a maximum of 50m from the control unit (Either the O2LA or EW).
- The cable size should be a minimum of 0.5mm² and there are 8 connections.
- The reader cable must be separate from the lock release cable.
- The reader cable should be screened. (Screen earthed at the CPU end)

Data bus connections between O2LA CPU and additional EW CPU's

- The maximum distance from furthest CPU to furthest CPU should be no more than 1km
- A 2 core twisted pair screened cable is required. 0.2mm² or larger can be used.
- Screen should be connected at both ends.
- End of line resistors should be fitted at the two extremes. The resistor value will depend on overall distance (Please refer to system manual).

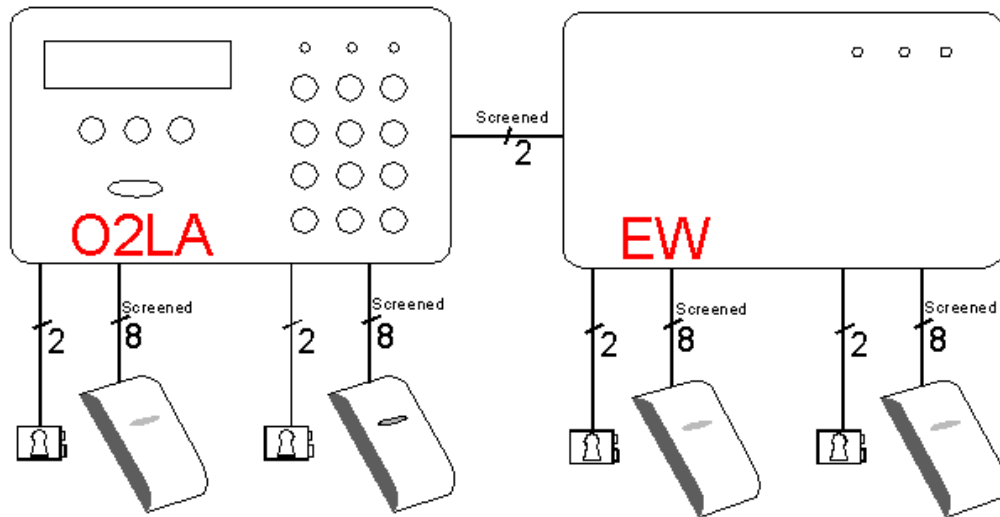

RS232 Link (For PC, Modem or serial printer)

- Please use supplied cable (Max. distance is 15m)

Connections for power supply output and lock release.
 (Each CPU (O2LA & EW's) requires its own 12Vdc PSU.)

	50m	100m
Connections	0.5mm ²	0.75mm ²

The power supply should be located as close to the door panel as possible for best performance.
 Maximum acceptable resistance for above cables = 3Ω

Lock release cables should not be included in the same multi core as for the reader, push to exit or door contacts.

CODIX Data Bus (Used on the EX5/EX7 range of keypads)

- Three wire bus for a maximum distance of 200m when used between two devices and 100m when used between 3 or more Devices
- Data bus core size should be 0.5mm² each (Twisted pairs not essential)
- Power supply must be no more than 10m from master unit. (Two 1.0mm² cores)

3+1 systems:

Systems covered under the 3+1 header are: 3K kits, DK1 kit, DK2 kit, 836M amplifier, 837M amplifier, SLK kits, 4837 amplifiers, DK4K kits, SMK kits, KPX kits and the 436 amplifier.

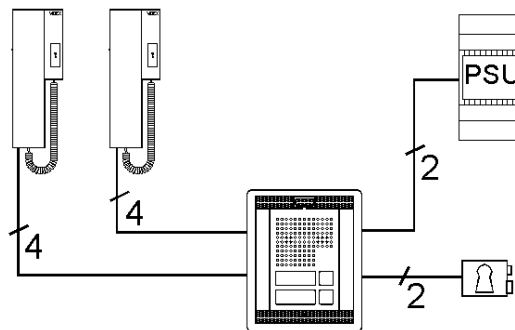

Connections from door panel to telephone.

Connections	50m	100m	200m	300m	400m
1	0.25mm ²	0.35mm ²	0.5mm ²	0.75mm ²	1.0mm ²
2	0.25mm ²	0.35mm ²	0.5mm ²	0.75mm ²	1.0mm ²
3	0.25mm ²	0.35mm ²	0.5mm ²	0.75mm ²	1.0mm ²
4	0.25mm ²	0.35mm ²	0.5mm ²	0.75mm ²	1.0mm ²

When ever possible connection 1(Tx) should be twisted with connection 3(Gnd) and connection 2(Rx) should be twisted with connection 3(Gnd) as pairs.
 Maximum acceptable resistance for above cables = 10Ω

Connections for power supply output and lock release.

Connections	50m	100m
	0.5mm ²	0.75mm ²

The power supply should be located as close to the door panel as possible for best performance.
 Maximum acceptable resistance for above cables = 3Ω

4+1 systems:

Systems covered under the 4+1 header are: EK kits, DK918 kits, 836 amplifier, 837 amplifier, VRDK kits, IK kits, 536 amplifier, 437 amplifier and the 537 amplifier.

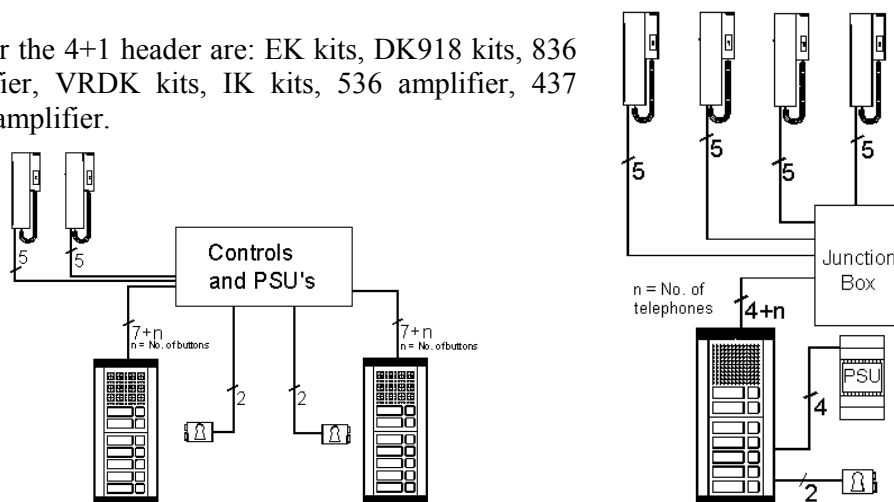

Connections from door panel to telephone.

Connections	50m	100m	200m	300m	400m
1	0.25mm ²	0.35mm ²	0.5mm ²	0.75mm ²	1.0mm ²
2	0.25mm ²	0.35mm ²	0.5mm ²	0.75mm ²	1.0mm ²
3	0.5mm ²	0.75mm ²	1.5mm ²	2.0mm ²	2.5mm ²
5	0.5mm ²	0.75mm ²	1.5mm ²	2.0mm ²	2.5mm ²
6	0.25mm ²	0.35mm ²	0.5mm ²	0.75mm ²	1.0mm ²

When ever possible connection 1(Tx) should be twisted with connection 3(Gnd) and connection 2(Rx) should be twisted with connection 3(Gnd) as pairs.
Maximum acceptable resistance for terminals 1,2 & 6 = 10Ω and for terminals 3 & 5 = 3Ω

Connections for power supply output and lock release.

	50m	100m
Connections	0.5mm ²	0.75mm ²

The power supply should be located as close to the door panel as possible for best performance.
Maximum acceptable resistance for above cables = 3Ω

ESK 2 Wire kit:

Connections from door panel to telephone.

Connections	50m	100m	200m
1	0.35mm ²	0.5mm ²	0.75mm ²
2	0.35mm ²	0.5mm ²	0.75mm ²

Maximum acceptable resistance for terminals = 6Ω
Transformer should be mounted within 20m of the audiophone and connected using 1.0mm² cores
Maximum resistance for lock connections = 3Ω

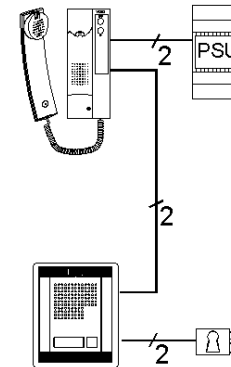

VK6N & SMVK systems:

Systems covered under this header are: All variations on mono videokits (Non-coax).

Connections from door panel to videophone.

Connections	50m	100m	200m	300m
1(6)	0.35mm ²	0.5mm ²	0.75mm ²	1.0mm ²
2(2)	0.35mm ²	0.5mm ²	0.75mm ²	1.0mm ²
+(4)	0.35mm ²	0.75mm ²	1.5mm ²	2.0mm ²
-(3)	0.35mm ²	0.75mm ²	1.5mm ²	2.0mm ²
V1(15)	0.35mm ²	0.5mm ²	0.75mm ²	1.0mm ²
V2(1)	0.35mm ²	0.5mm ²	0.75mm ²	1.0mm ²

Connections V1(15) & V2(1) must be a twisted pair

When ever possible connection 1(6)[Tx] should be twisted with connection -(3)[Gnd] and connection 2(2)[Rx] should be twisted with connection -(3)[Gnd] as pairs.

Maximum acceptable resistance for terminals 1(6),2(2), V1(15) & V2(1) = 10Ω and for terminals +(4) & -(3) = 3Ω

Note: Block diagram as per CVK6N & CSMVK

Connections for power supply output and lock release.

The power supply must be connected as close to the videophone as possible and within a maximum of 20m.

Recommended cable size is 1.0mm² (Plus two 0.35mm² cables from power supply when using 850K/MV PSU).

Maximum acceptable resistance for above cables = 3Ω

CVK6N & CSMVK systems:

Systems covered under this header are: All variations of colour videokit (non-coax).

Connections from door panel to videophone.

Connections	50m	100m	200m
1(6)	0.35mm ²	0.5mm ²	0.75mm ²
2(2)	0.35mm ²	0.5mm ²	0.75mm ²
+(4)	0.5mm ²	1.5mm ²	2.0mm ²
-(3)	0.5mm ²	1.5mm ²	2.0mm ²
V1(15)	0.35mm ²	0.5mm ²	0.75mm ²
V2(1)	0.35mm ²	0.5mm ²	0.75mm ²

Connections V1(15) & V2(1) must be a twisted pair

When ever possible connection 1(6) should be twisted with connection -(3) and connection 2(2) should be twisted with connection -(3) as pairs.

Maximum acceptable resistance for terminals 1(6),2(2), V1(15) & V2(1) = 10Ω and for terminals +(4) & -(3) = 3Ω

Connections for power supply output and lock release.

The power supply must be connected as close to the videophone as possible and within a maximum of 20m.

Recommended cable size is 1.0mm² (Plus two 0.35mm² cables from power supply when using 850K/MV PSU).

Maximum acceptable resistance for above cables = 3Ω

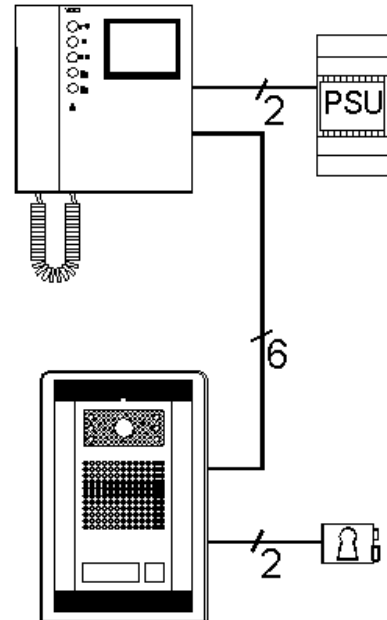

Coax video systems using the 890 controller:

Connections from door panel to the Art.890 controller.

Connections	50m	100m	200m	300m	400m
T	0.35mm ²	0.5mm ²	0.5mm ²	0.75mm ²	1.0mm ²
A	0.5mm ²	1.0mm ²	1.5mm ²	2.0mm ²	2.5mm ²
+8	0.35mm ²	0.5mm ²	0.75mm ²	1.0mm ²	1.5mm ²
F	0.35mm ²	0.5mm ²	0.75mm ²	1.0mm ²	1.5mm ²
I	0.35mm ²	0.5mm ²	1.0mm ²	1.5mm ²	2.0mm ²
G2	0.35mm ²	0.35mm ²	0.5mm ²	0.75mm ²	1.0mm ²
H1	0.35mm ²	0.5mm ²	0.75mm ²	1.0mm ²	1.5mm ²
F1	0.35mm ²	0.5mm ²	0.75mm ²	1.0mm ²	1.5mm ²
F2	0.35mm ²	0.5mm ²	0.75mm ²	1.0mm ²	1.5mm ²
SE	0.5mm ²	1.0mm ²	1.5mm ²	2.0mm ²	2.5mm ²
V	Standard quality	Medium quality	Good quality	Good quality	High quality
M	75Ω Coax cable	75Ω Coax cable	75Ω Coax cable	75Ω Coax cable	75Ω Coax cable

When ever possible connection H1(Tx) should be twisted with connection F(Gnd) and connection G2(Rx) should be twisted with connection F(Gnd) as pairs.

Maximum acceptable resistance for terminals T, G2, H1 = 10Ω and for terminals A, +8, F, F1 & I = 6Ω and for terminals SE & F2 = 3Ω

V is the centre core of the coax and M is the screen.

The transformer should be mounted next to the Art.890 and connected using 1mm² cores

Connections from the Art.890 controller to the videophone.

Connections	50m	100m	200m	300m	400m
+12(1)	0.35mm ²	0.35mm ²	0.5mm ²	0.75mm ²	1.0mm ²
TV1(2)	0.35mm ²	0.35mm ²	0.5mm ²	0.75mm ²	1.0mm ²
TV2(2)	0.35mm ²	0.35mm ²	0.5mm ²	0.75mm ²	1.0mm ²
1(4)	0.35mm ²	0.5mm ²	1.0mm ²	1.5mm ²	2.0mm ²
2(5)	0.35mm ²	0.35mm ²	0.5mm ²	0.75mm ²	1.0mm ²
3(6)	0.35mm ²	0.35mm ²	0.5mm ²	0.75mm ²	1.0mm ²
4(7)	0.35mm ²	0.35mm ²	0.5mm ²	0.75mm ²	1.0mm ²
5(8)	0.35mm ²	0.35mm ²	0.5mm ²	0.75mm ²	1.0mm ²
6(9)	0.35mm ²	0.5mm ²	1.0mm ²	1.5mm ²	2.0mm ²
7(10)	0.35mm ²	0.35mm ²	0.5mm ²	0.75mm ²	1.0mm ²
V(11)	Standard quality	Medium quality	Good quality	Good quality	High quality
M(12)	75Ω Coax cable	75Ω Coax cable	75Ω Coax cable	75Ω Coax cable	75Ω Coax cable
R(13)	0.35mm ²	0.35mm ²	0.5mm ²	0.75mm ²	1.0mm ²
C(14)	0.35mm ²	0.35mm ²	0.5mm ²	0.75mm ²	1.0mm ²
-(15)	0.35mm ²	0.35mm ²	0.5mm ²	0.75mm ²	1.0mm ²
T(16)	0.35mm ²	0.35mm ²	0.5mm ²	0.75mm ²	1.0mm ²
1T(17)	0.35mm ²	0.35mm ²	0.5mm ²	0.75mm ²	1.0mm ²
2T(18)	0.35mm ²	0.35mm ²	0.5mm ²	0.75mm ²	1.0mm ²

When ever possible connection 3(6) should be twisted with connection 5(8) and connection 4(7) should be twisted with connection 5(8) as pairs.
 Maximum acceptable resistance for all terminals except 1(4) & 6(9) = 10Ω and terminals 1(4) & 6(9) = 6Ω
 V is the centre core of the coax and M is the screen.

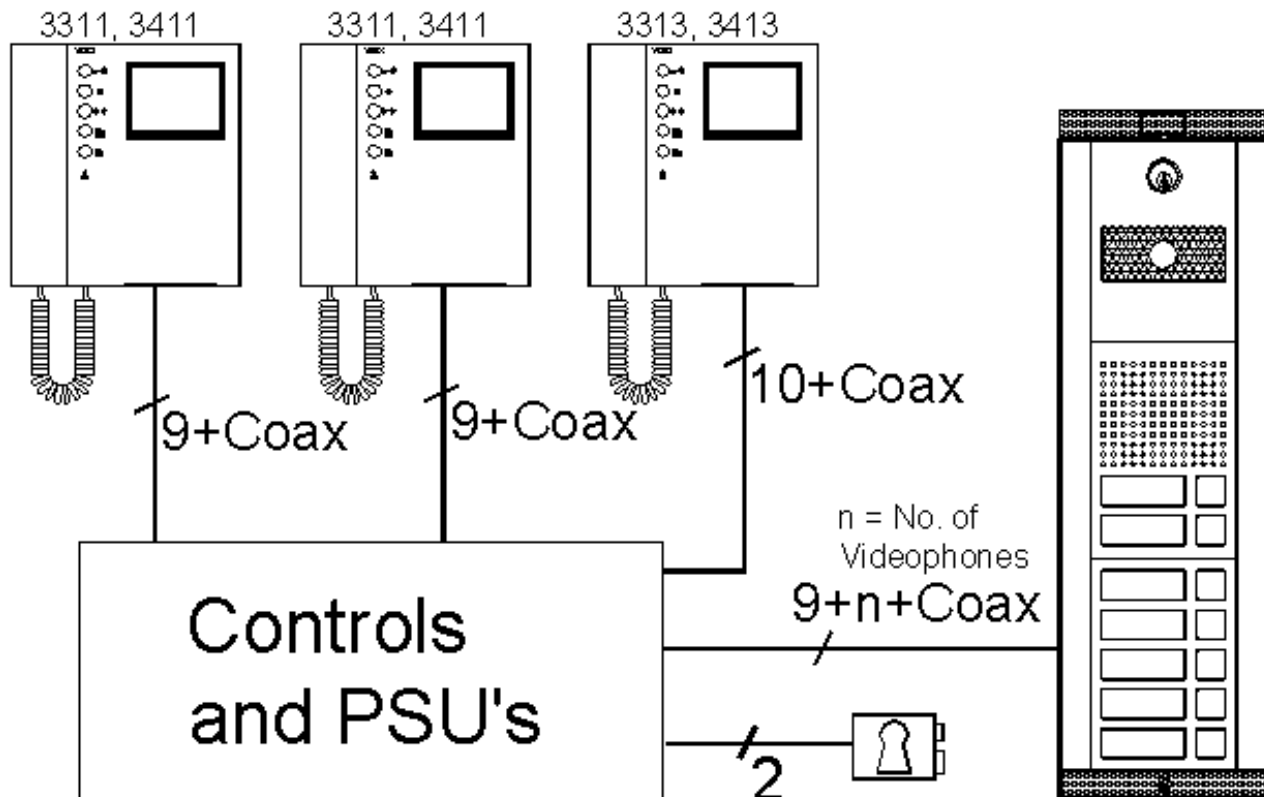

Sentry and Sentry 1 systems:

Connections from door panel to the control cabinet.

Connections	50m	100m	200m	300m	400m
Amp 1	0.25mm ²	0.35mm ²	0.5mm ²	0.75mm ²	1.0mm ²
Amp 2	0.25mm ²	0.35mm ²	0.5mm ²	0.75mm ²	1.0mm ²
Amp 3	0.25mm ²	0.35mm ²	0.5mm ²	0.75mm ²	1.0mm ²
Amp 4	0.25mm ²	0.35mm ²	0.5mm ²	0.75mm ²	1.0mm ²
CB	0.25mm ²	0.35mm ²	0.5mm ²	0.75mm ²	1.0mm ²
Selects 1-n	0.25mm ²	0.35mm ²	0.5mm ²	0.75mm ²	1.0mm ²
A	0.25mm ²	0.35mm ²	0.5mm ²	0.75mm ²	1.0mm ²
Trade	0.25mm ²	0.35mm ²	0.5mm ²	0.75mm ²	1.0mm ²
Trade	0.25mm ²	0.35mm ²	0.5mm ²	0.75mm ²	1.0mm ²
Lock	0.5mm ²	0.75mm ²	1.5mm ²	2.0mm ²	2.5mm ²
Lock	0.5mm ²	0.75mm ²	1.5mm ²	2.0mm ²	2.5mm ²
V	Standard quality	Medium quality	Good quality	Good quality	High quality
M	75Ω Coax cable	75Ω Coax cable	75Ω Coax cable	75Ω Coax cable	75Ω Coax cable
I (+20)	0.35mm ²	0.5mm ²	1.0mm ²	1.5mm ²	2.0mm ²
F1 (Vid 0V)	0.35mm ²	0.5mm ²	0.75mm ²	1.0mm ²	1.5mm ²
SB (+12V)	0.25mm ²	0.35mm ²	0.5mm ²	0.75mm ²	1.0mm ²

Lines in red are only required on video systems.

When ever possible connection 1(Rx) should be twisted with connection 4(Gnd) and connection 2(Tx) should be twisted with connection 4(Gnd) as pairs. Maximum acceptable resistance for all terminals except lock = 10Ω and for lock terminals = 3Ω

V is the centre core of the coax and M is the screen.

For best performance, keep the distance between the door panel and the control cabinet to a minimum.

Connections from the control cabinet to the videophone.

Connections	50m	100m	200m	300m	400m
1	0.35mm ²	0.35mm ²	0.5mm ²	0.75mm ²	1.0mm ²
2	0.35mm ²	0.35mm ²	0.5mm ²	0.75mm ²	1.0mm ²
-	0.35mm ²	0.35mm ²	0.5mm ²	0.75mm ²	1.0mm ²
4(T)	0.35mm ²	0.35mm ²	0.5mm ²	0.75mm ²	1.0mm ²
5(P)	0.35mm ²	0.35mm ²	0.5mm ²	0.75mm ²	1.0mm ²
6(C)	0.35mm ²	0.35mm ²	0.5mm ²	0.75mm ²	1.0mm ²
D	0.35mm ²	0.35mm ²	0.5mm ²	0.75mm ²	1.0mm ²
V(11)	Standard quality	Medium quality	Good quality	Good quality	High quality
M(12)	75Ω Coax cable	75Ω Coax cable	75Ω Coax cable	75Ω Coax cable	75Ω Coax cable
+20	0.35mm ²	0.5mm ²	1.0mm ²	1.5mm ²	2.0mm ²
Vid Gnd	0.35mm ²	0.5mm ²	1.0mm ²	1.5mm ²	2.0mm ²
+12	0.35mm ²	0.35mm ²	0.5mm ²	0.75mm ²	1.0mm ²
T(16)	0.35mm ²	0.35mm ²	0.5mm ²	0.75mm ²	1.0mm ²
1T(17)	0.35mm ²	0.35mm ²	0.5mm ²	0.75mm ²	1.0mm ²
2T(18)	0.35mm ²	0.35mm ²	0.5mm ²	0.75mm ²	1.0mm ²

Lines in black are required on all audio and videophones

Lines in red are only required on videosystems.

Lines in blue are only required on videophones and audiophones with privacy and/or door monitoring.

When ever possible connection 1 should be twisted with connection - and connection 2 should be twisted with connection - as pairs.

Maximum acceptable resistance for all terminals except +20 & Vid Gnd = 10Ω and terminals +20 & Vid Gnd = 6Ω

V is the centre core of the coax and M is the screen.

Sentry and Sentry 1 Audio system block diagram:-

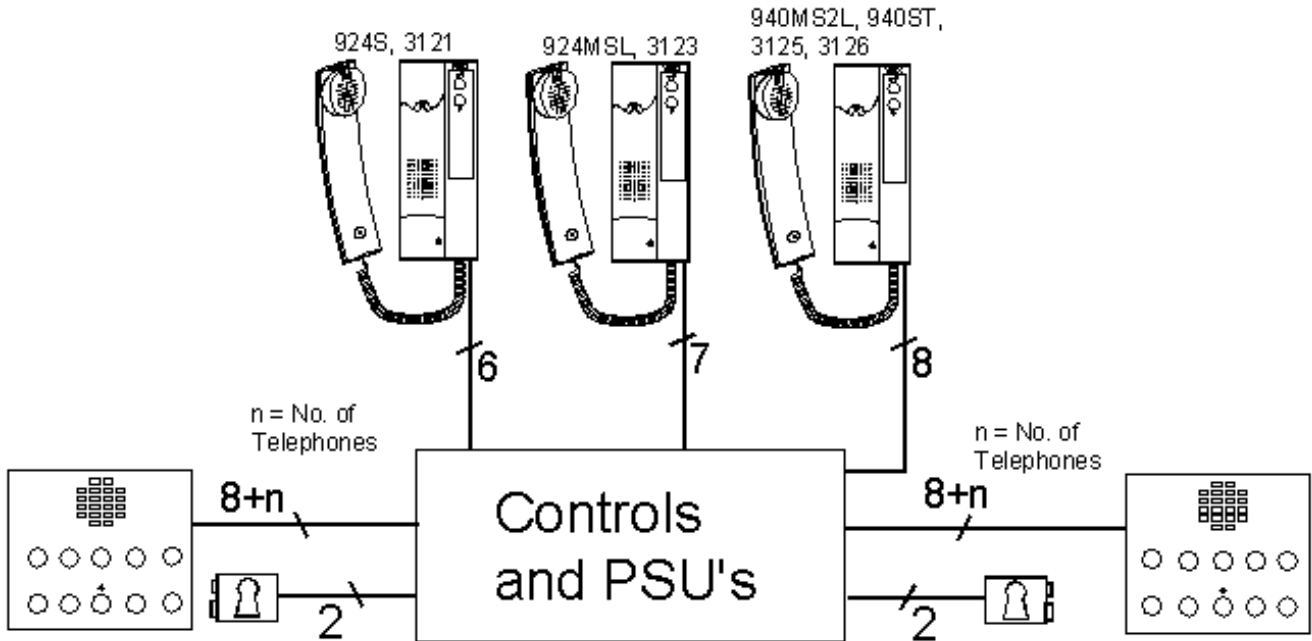

Sentry and Sentry 1 Video system block diagram:-

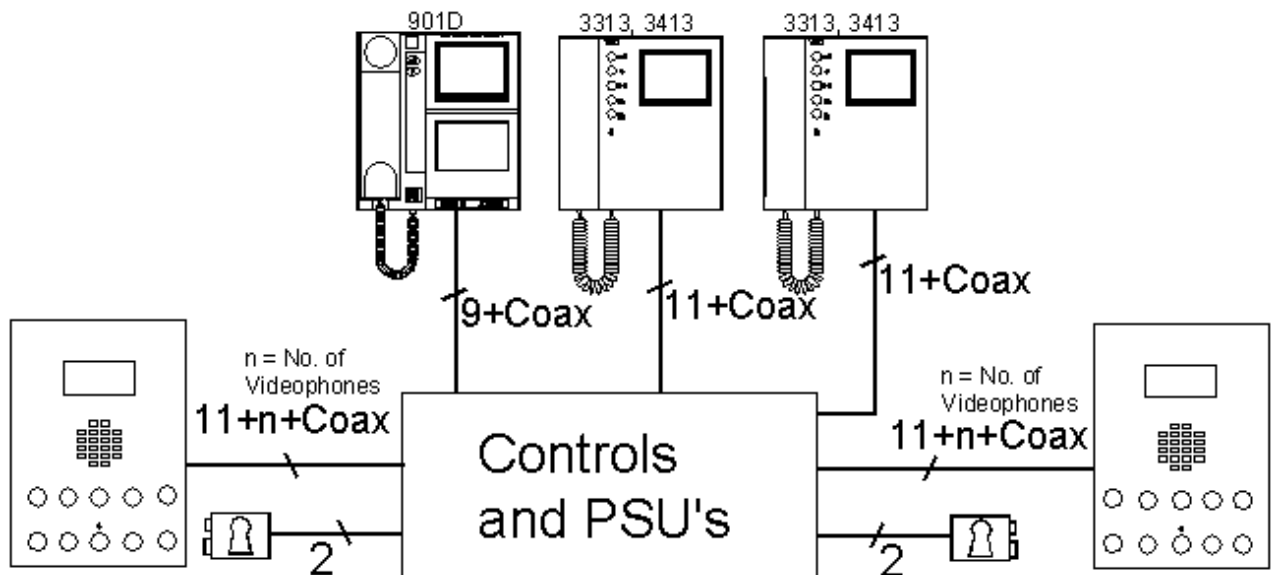

VX2200 Digital system:

Connections from door panel to telephone.

Connections	50m	100m	200m	300m	400m	500m
L	0.4mm ²	0.5mm ²	0.75mm ²	1.0mm ²	1.5mm ²	2.5mm ²
-	0.4mm ²	0.5mm ²	0.75mm ²	1.0mm ²	1.5mm ²	2.5mm ²
V1	0.35mm ²	0.5mm ²	0.75mm ²	1.0mm ²	1.5mm ²	2.0mm ²
V2	0.35mm ²	0.5mm ²	0.75mm ²	1.0mm ²	1.5mm ²	2.0mm ²
+20	0.5mm ²	0.75mm ²	1.0mm ²	1.5mm ²	2.0mm ²	
Vid Gnd	0.5mm ²	0.75mm ²	1.0mm ²	1.5mm ²	2.0mm ²	
+LED	0.25mm ²	0.5mm ²	0.75mm ²	1.0mm ²	1.5mm ²	

Lines in red are only required on video systems

Lines in blue are only required on telephones with door monitoring LED

V1 & V2 MUST BE A TWISTED PAIR. L & - SHOULD ALSO BE A TWISTED PAIR.

Maximum acceptable resistance for all terminals = 7.5Ω except for +20 & Vid Gnd = 5Ω

Maximum of 400m for video systems.

Power supply should be as close to door panel as possible, wired in 1.0mm² cores and a maximum resistance of 5Ω.

Single entrance audio system

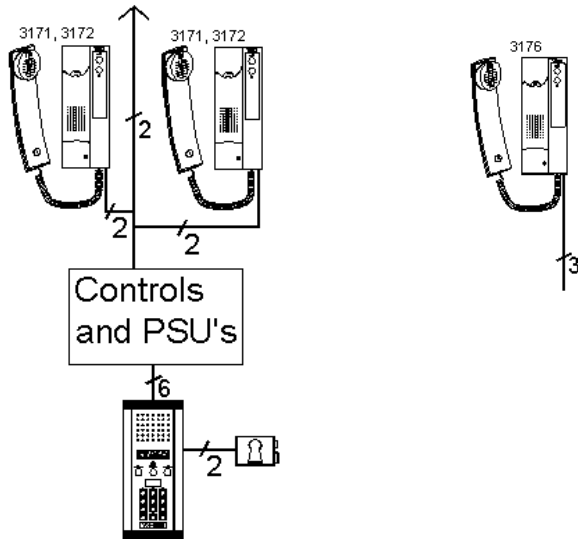

Multiple main entrance audio system

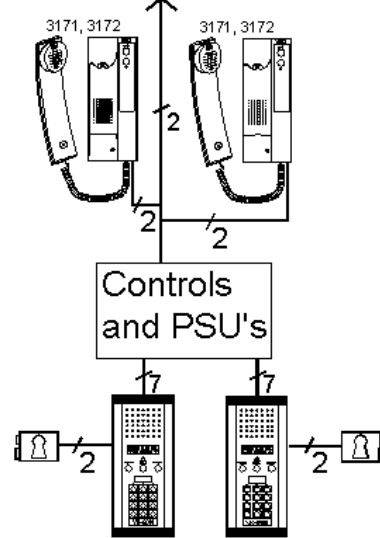

Single entrance video system

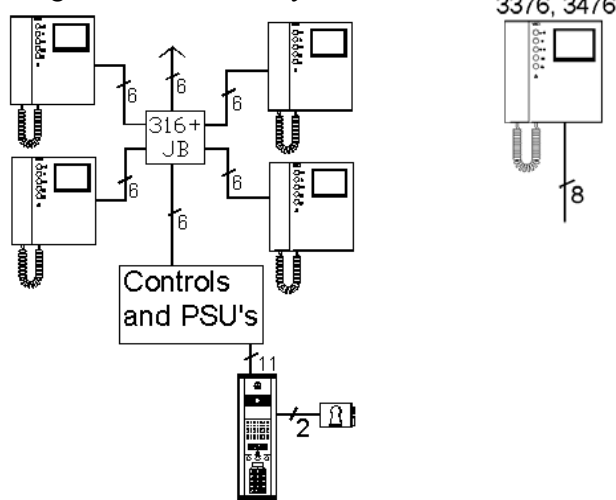

Multiple main entrance video system

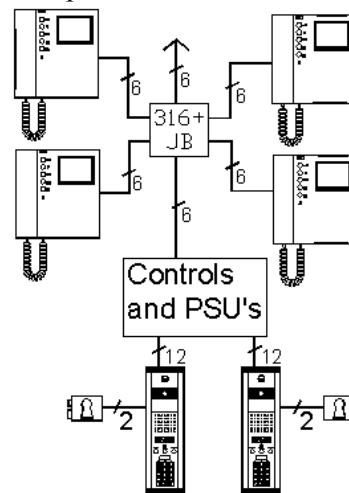

Two level audio system

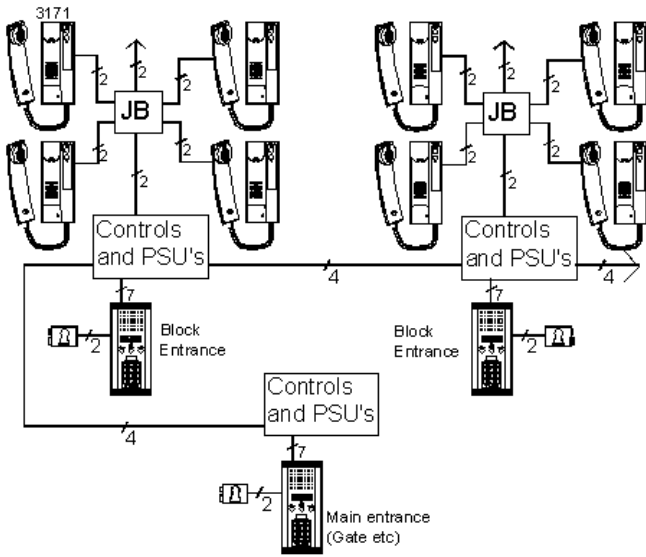

Two level video system

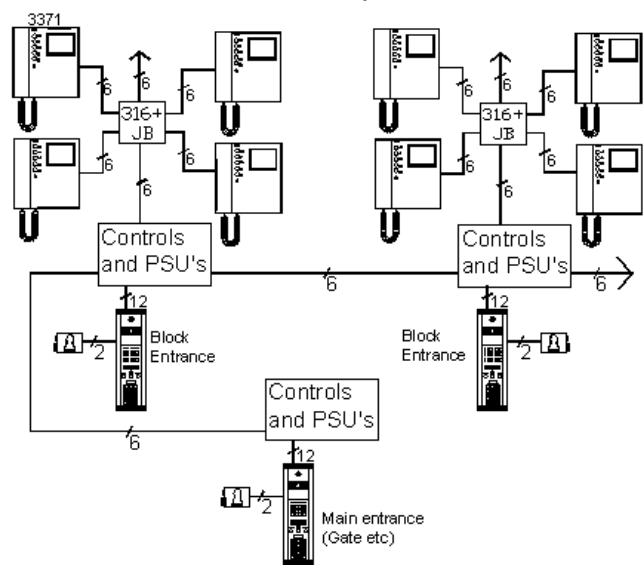

Audio system with concierge

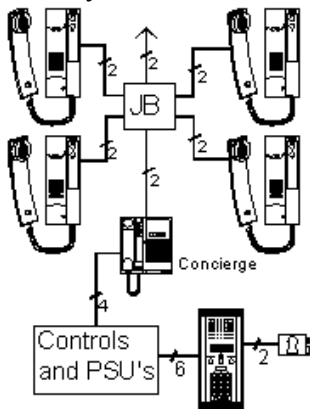

Video system with concierge

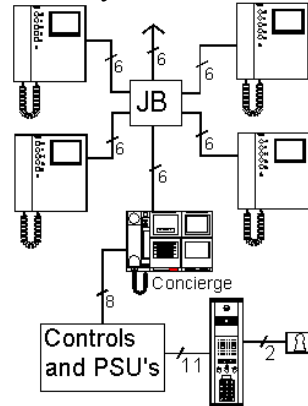

VX2000 Digital system:

Bus connections

Connections	50m	100m	200m	300m	400m	500m	600m
F1	0.25mm ²	0.5mm ²	0.5mm ²	0.75mm ²	1.0mm ²	1.5mm ²	2.0mm ²
F2	0.25mm ²	0.5mm ²	0.5mm ²	0.75mm ²	1.0mm ²	1.5mm ²	2.0mm ²
-	0.25mm ²	0.5mm ²	0.75mm ²	1.0mm ²	1.5mm ²	2.0mm ²	2.5mm ²
+	0.25mm ²	0.5mm ²	0.75mm ²	1.0mm ²	1.5mm ²	2.0mm ²	2.5mm ²
CK	0.25mm ²	0.5mm ²	0.5mm ²	0.75mm ²	1.0mm ²	1.5mm ²	2.0mm ²
DA	0.25mm ²	0.5mm ²	0.5mm ²	0.75mm ²	1.0mm ²	1.5mm ²	2.0mm ²
+20	0.25mm ²	0.75mm ²	0.75mm ²	1.0mm ²	1.5mm ²	2.0mm ²	2.5mm ²
Vid Gnd	0.25mm ²	0.75mm ²	0.75mm ²	1.0mm ²	1.5mm ²	2.0mm ²	2.5mm ²
V	Standard	Standard	Good quality	Good quality	High quality	High quality	High quality
M	75Ω Coax cable	75Ω Coax cable	75Ω Coax cable	75Ω Coax cable	75Ω Coax cable	75Ω Coax cable	75Ω Coax cable

Lines in red are only required on video systems.

For best performance and to avoid audio and data problems, F1 & - should be a twisted pair, F2 & - should be a twisted pair, CK & - should be a twisted pair and DA & negative should be a twisted pair. This will not be necessary on small distances.

Maximum acceptable resistance for terminals F1, F2, CK & DA = 10Ω.

Maximum resistances for terminals +, -, +20 & Vid GND = 5Ω

Multiple main entrance audio system

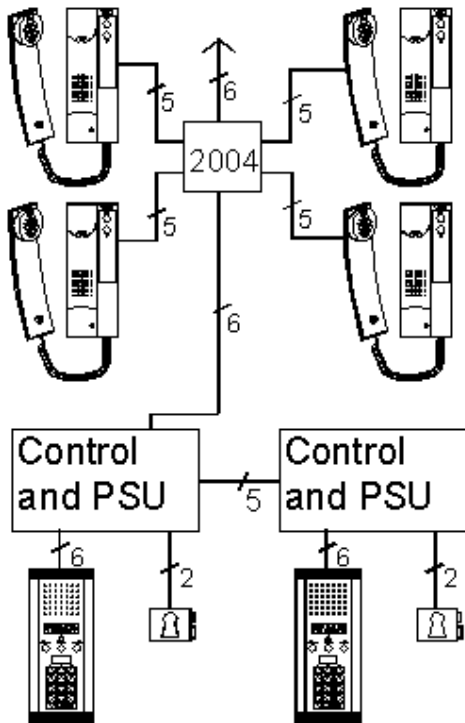

Multiple main entrance video system

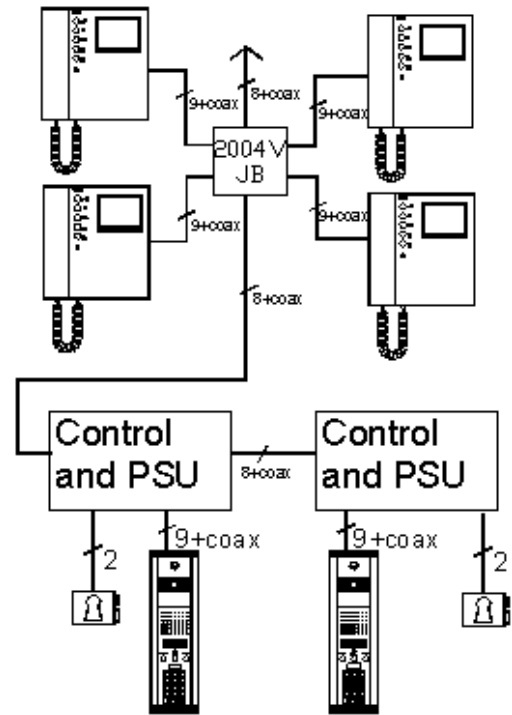

Audio system with concierge

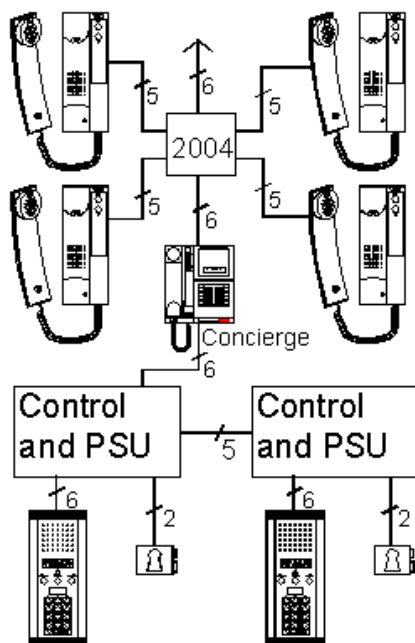

Video system with concierge

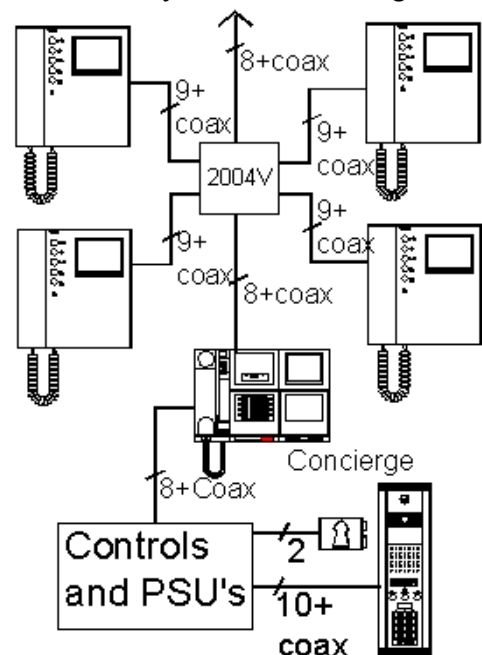

A NOTE ON MAINS VOLTAGE CONNECTIONS:

- ✓ All connections to mains voltages must be made to the current national standards (IEE Wiring regulations).
- ✓ All intercom and access control cables must be routed separately from the mains.
- ✓ An all pole circuit breaker must be used to connect the equipment to the mains.