

The lightning flash with an arrowhead symbol, within an equilateral triangle is intended to alert the user to the presence of uninsulated dangerous voltage within the product's enclosure that may be of sufficient magnitude to constitute a risk of electric shock to persons.



The exclamation point within an equilateral triangle is intended to alert the user to the presence of important operating and maintenance (servicing) instructions in the literature accompanying the appliance.

INFORMATION - This equipment has been tested and found to comply with limits for a Class A digital device, pursuant to part 15 of the FCC Rules & CE Rules. These limits are designed to provide reasonable protection against harmful interference when the equipment is operated in a commercial environment. This equipment generates, uses, and can radiate radio frequency energy and, if not installed and used in accordance with the instruction manual, may cause harmful interference to radio communications. Operation of this equipment in a residential area is likely to cause harmful interference in which case the user will be required to correct the interference at his own expense.

WARNING - Changes or modifications not expressly approved by the manufacturer could void the user's authority to operate the equipment.

CAUTION : To prevent electric shock and risk of fire hazards:

- ◆ Do NOT use power sources other than those specified.
- ◆ Do NOT expose this appliance to rain or moisture.

This installation should be made by a qualified service person and should conform to all local codes.

■ Contents

Features	04
Precautions	06
Components and Accessories	08
Names and Functions of Parts	09
■ Front	09
■ Top	10
■ Rear	11
Installation	12
■ Lens	12
· Using the auto iris	
· Using a C/CS mount lens	
■ Connecting to a monitor	15
■ Connecting to power	15

Menu Flow	16
■ Setup Page Menu	17
· LENS	18
· EXPOSURE	19
· White Balance (White Bal.)	21
· SDDR (Super Dynamic Range)	22
· BACK LIGHT	23
· DNR3 (Super Noise Reduction)	24
· DAY/NIGHT	25
· SPECIAL	26
- IMAGE ADJ	27
- MONITOR	28
- CAM TITLE	28
- SYNS	29
- MOTION DET	30
- PRIVACY	30
- COMM ADJ	31
- LANGUAGE	32
- RETURN	32
· EXIT	32
Troubleshooting	33
Specifications	34

■ Features

Ultra High Resolution

By adopting a diagonal 6mm(1/3") 410,000 (NTSC) pixel, 470,000(PAL) pixel SONY CCD, the camera produces clear picture quality with a horizontal resolution of 600 TV lines for colour.

Excellent Sensitivity

The built-in high sensitivity COLOUR CCD enable a clear image even in 0.15Luxor lower illumination.

DNR3 (Super Noise Reduction)

The high-performance W-V DSP chip effectively removes low-light gain noise and afterimage to provide clear images even in dark environments.

Day & Night

The camera identifies whether it is day or night and automatically switches to the appropriate mode, depending on its environment. By day, the camera switches to colour mode in order to maintain optimal colour. At night, it switches to B/W mode so as to obtain better picture definition.

Motion Detection

Since the camera detects motion without any additional external sensor, you can monitor activity more efficient.

DIS (Digital Image Stabilizer)

The DIS function compensates for any camera movement, to produce more stable pictures.

SSDR (Super Dynamic Range)

For images with high contrast between bright and dark spots from difficult lighting conditions such as backlighting, this camera selectively illuminates darker spots while retaining the same light level for brighter spots to even out the overall brightness.

Video/DC Drive Lens Support

You can select Video or DC Drive Lens from the menu.

OSD

The camera control is convenient by using 8 different foreign language O.S.D.
- NTSC : Korean, English, French, Spanish, Japanese, Portuguese
- PAL : English, French, German, Spanish, Italian, Chinese, Russian, Czech, Polish

Miscellaneous functions

HLC(High Light Compensation), SENS-UP, FLIP (H/V-REV), D-ZOOM, SHARPNESS, MOTION DETECTION and PRIVACY functions are provided.

Warning ■

The camera requires periodic inspection.

Contact an authorised technician to carry out the inspection.

Stop using your camera when you find it malfunctioning.

If the camera emits smoke or is unusually hot for a long period, a fire may be caused.

Do not install the camera on a surface that can not support it.

If the camera is installed on an inappropriate surface, it may fall and cause injury.

Do not hold plug with wet hands.

It could cause an electric shock.

Do not dis-assemble the camera.

It may result in an electric shock or other hazards.

Do not use the camera close to a gas or oil leak.

It may result in a fire or other hazards.

■ Precautions

Do not install the camera in extreme temperature conditions.



Only use the camera under conditions where temperatures are between -10°C and $+50^{\circ}\text{C}$. Be especially careful to provide ventilation when operating under high temperatures.

Do not install or use the camera in an environment where the humidity is high.



It can cause the image quality to be poor.

Do not install the camera under unstable lighting conditions.

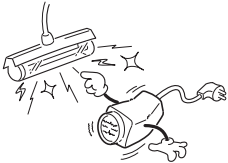

Severe lighting change or flicker can cause the camera to work improperly.

Do not touch the front lens of the camera.



This is one of the most important parts of the camera. Be careful not to leave fingerprints on the lens cover.

Do not drop the camera and protect it from physical shocks.



It can cause malfunctions to occur.

Never keep the camera pointed directly at strong light.

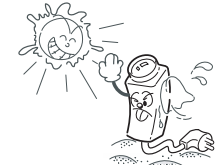

It can damage the CCD.

Do not expose the camera to rain or spill beverage on it.



If it gets wet, wipe it dry immediately. Liquids can contain minerals that corrode the electronic components.

Do not expose the camera to radioactivity.



If exposed to radioactivity the CCD will fail.



Note

- If the camera is exposed to spotlight or an object reflecting strong light, smear or blooming may occur.
- Please check the power supply satisfies the normal specification before connecting the camera.

1. Colour Box Camera

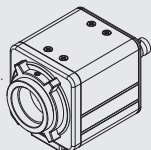

2. Auto Iris Lens Connector Plug

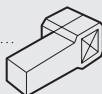

3. L-Wrench



4. C-Mount Adapter



5. Instruction Manual



Front

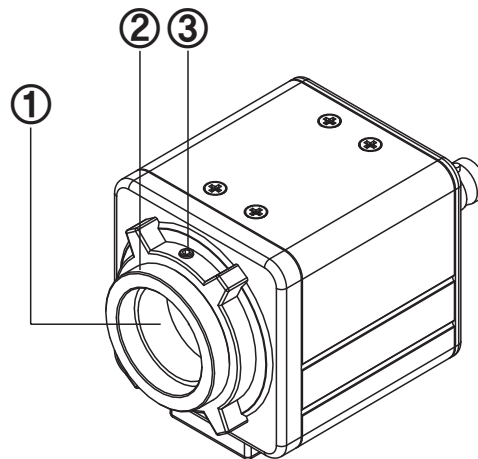

① Lens protection cap

Cover the lens when not using it.

② CS-Mount lens adaptor

Attach the CS-Mount lens here.

③ Back Focus clamp screw

Loosen the clamp screw with a screwdriver before adjusting the Back Focal length.

Overview

Rear

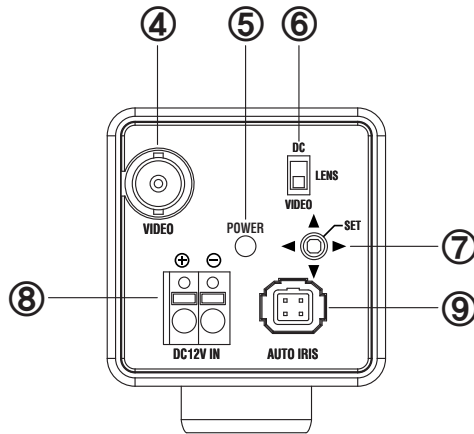

④ Video output terminal

Sends video signals and connects to the video input terminal of the monitor.

⑤ Power lamp

Lights up when the correct power is supplied to the camera.

⑥ Auto iris lens selection switch

Please change the mode to DC or VIDEO depending on the type of auto iris lens being used.

⑦ Setting button

● **SET** : Used to access menu mode and for configuration.

▲ : Moves cursor up in the menu screen.

▼ : Moves cursor down the menu screen.

◀ : Moves cursor left in the menu screen.

: Parameter change.

▶ : Moves cursor right in the menu screen.

: Parameter change.

⑧ Power input terminal

Connects to the power appropriate to each power requirement.

⑨ Auto iris lens connector

This is the connection terminal for the auto iris lens.

Overview

Lens

Lenses are sold separately. Lenses such as auto iris lens, CS-Mount lens and C-Mount lens can be used.

Note

- Use of the DC auto iris lens is recommended to achieve the best results for operating this product effectively.
- Keep the lens clean.
- Any foreign objects and fingermarks on the lens can cause inferior image quality in low light level conditions.

When using an auto iris lens

1. Peel off about 8mm of the outer skin of the auto iris lens cable.

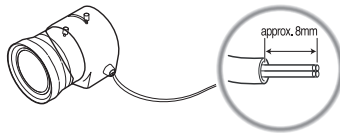

2. Peel off about 2mm of the outer skin of the insulated conductor inside the lens cable.

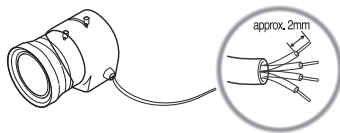

Installation Procedures

3. Remove the cover of the auto iris lens connection plug and solder the lens cable to the connector pin in the plug.

Pin No.	LENS	
	DC	VIDEO
No.1 Pin	Damping-	Red(power)
No.2 Pin	Damping+	NC
No.3 Pin	Drive+	White(video signal)
No.4 Pin	Dreve-	Black(GND)

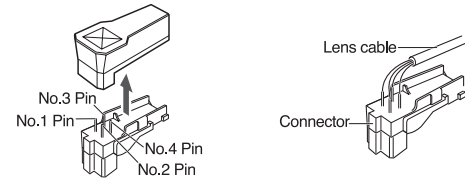

4. Replace the auto iris lens connection plug cover and take off the lens protection cap, and then attach the auto iris lens to the camera by screwing it in clockwise.
5. Insert the connection plug that is connected to the auto iris lens cable into the auto lens connector, which is located on the back of the camera.

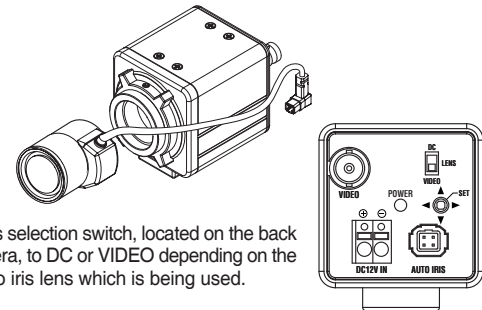

6. Set the lens selection switch, located on the back of the camera, to DC or VIDEO depending on the type of auto iris lens which is being used.

■ Installation Procedures

When using a CS-Mount lens

Take off the lens protection cap and attach the CS-Mount lens to the camera by screwing it in clockwise.

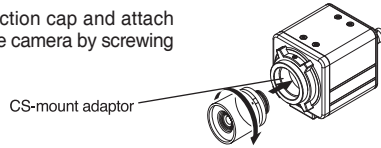

When using a C-Mount lens

1. Take off the lens protection cap and attach the C-mount adaptor.

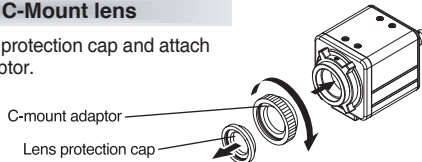

2. Attach the C-Mount lens to the camera by screwing it in clockwise.

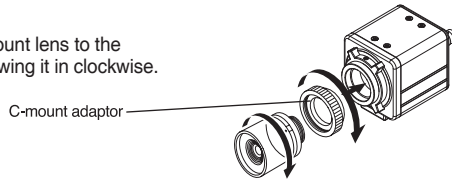

Note

- Use the specified lens connection parts as shown in the picture below. The use of the wrong sized parts may cause damage to the inside of the camera or result in poor fitting.
- Use of a lens which is too heavy affects the balance of the camera and may cause a malfunction. Please use a lens that weighs less than 450g.
- Select Av mode if possible when adjusting the automatic light control (ALC) of an auto lens. Use of PK mode may cause hunting.

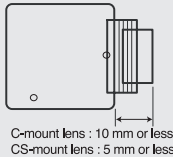

C-mount lens : 10 mm or less
CS-mount lens : 5 mm or less

■ Connecting to a monitor

Connect the video output terminal located on the back of the camera to the monitor.

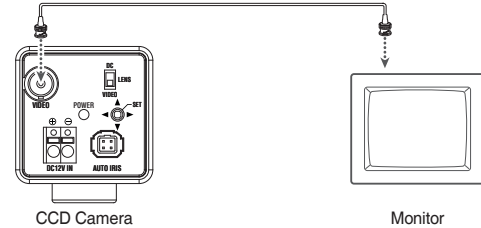

- The connection method varies depending on the type of monitor and accessories. Please refer to the user's manual for each instrument.
- Turn off the power when connecting.

■ Connecting to power

Check the standard power requirement before connecting to power.

DC Power Type (DC 12V, 500mA)

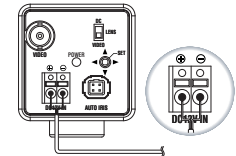

How to Use the Camera

Menu

SETUP menu			
LENS (selection)	· DC	· VIDEO	· MANUAL
EXPOSURE	· BRIGHTNESS · SENS-UP	· SHUTTER · RETURN	· AGC
WHITE BALANCE	· ATW · MANUAL	· OUTDOOR · AWC→SET	· INDOOR
SSDR	· OFF	· ON	
BACKLIGHT	· OFF	· BLC	· HLC
DNR3	· OFF	· ON	
DAY/NIGHT	· AUTO · EXTERN	· COLOR	· B/W
SPECIAL	· IMAGE ADJ. · SYNC · COMM ADJ	· MONITOR · MOTION DET · LANGUAGE	· CAM TITLE · PRIVACY · RETURN
EXIT	· SAVE	· NOT SAVE	· RESET

Settings

Settings can be made using the 5 buttons on the rear of the camera.

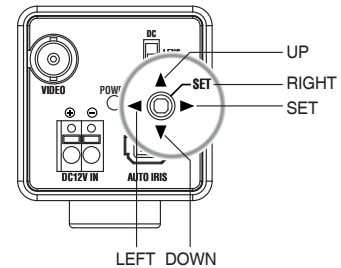

1. Press the SET button
 - Settings can now be made. The SETUP menu is displayed on the monitor.

MAIN MENU	
1.LENS	DC ↕
2.EXPOSURE ↕	
3.WHITE BAL	ATW
4.SSDR	ON ↕
5.BACKLIGHT	OFF
6.DNR3	ON ↕
7.DAY/NIGHT	COLOR
8.SPECIAL ↕	
9.EXIT	SAVE

2. Select a menu item from the list available by using the UP and DOWN buttons.
 - Functions are selected using up and down buttons.
 - The selected position is displayed in blue.

How to Use the Camera

Select the function using the UP or DOWN button.

MAIN MENU	
1.LENS	DC ↕
2.EXPOSURE ↕	
3.WHITE BAL	ATW
4.SSDR	ON ↕
5.BACKLIGHT	OFF
6.DNR3	ON ↕
7.DAY/NIGHT	COLOR
8.SPECIAL ↕	
9.EXIT	SAVE

Change the status using the LEFT or RIGHT button.

- Set up a selected item by using the Left and Right buttons.
- To finish and save the settings, select 'EXIT' and press the SET button.

Note

- An item with the ↕ icon also has sub-menus. To select a sub-menu, press the SET button.
- An item with the - - - icon has no sub-menus available for selection.

LENS

Using this function, you can control the screen brightness.

- When the SETUP menu screen is displayed, select 'LENS' by using the Up and Down buttons so that the arrow indicates 'LENS'.
- Select the connected lens type by using the Left and Right buttons.

MAIN MENU	
1.LENS	DC ↕
2.EXPOSURE ↕	
3.WHITE BAL	ATW

- **DC/Video** : Select Auto Iris Lens
You can adjust the minimum shutter and maximum value of ESC shutter mode when DC Lens mode is selected.
 - **Manual** : Select Manual Lens
- Each Lens mode has sub menu items as listed below.
 - Brightness (DC, Manual) : Adjusts the video brightness.

- **IRIS SPEED (DC)** : Adjusts the Iris control speed of the DC lens. If the control speed is too slow or fast, please use this menu to adjust the speed.
- **FOCUS ADJ. (DC, VIDEO)** : To adjust the DC and VIDEO lens focus correctly, you must activate the Focus Settings mode under each lens menu. Activate the Focus Settings mode, adjust the lens focus, and then deactivate the settings mode. (The VIDEO lens requires an extra step: go to the sub menu of the Focus Settings mode and change the shutter speed to adjust the lens brightness.)

Note

- When using VIDEO lens, adjust the lens VR explained below first and set the focus using 'FOCUS ADJ.' menu.
- If colour rolling occurs when using a DC lens, set Shutter to A.FLK.
- Some lenses may not work properly, depending on the setting of the BRIGHTNESS LEVEL.
- When Using a Video-Type Auto Iris Lens
 - Adjust the ALC adjustment terminal on the lens appropriately.
In general, set it to AV (Average).
 - It may not work properly depending on the installed lens. Set the Level VR of the lens to the optimal value.
 - Set AGC to OFF and adjust the Lens VR to an appropriate brightness.
 - Adjust the Lens VR, adjust the BRIGHTNESS, and then check if the screen brightness changes properly. Otherwise, adjust the Lens VR again.

EXPOSURE

MAIN MENU	
1.LENS	DC ↕
2.EXPOSURE ↕	
3.WHITE BAL	ATW

- When the SETUP menu screen is displayed, select 'EXPOSURE' by using the Up and Down buttons so that the arrow indicates 'EXPOSURE'.
- Select a desired mode using the Up and Down buttons.

■ How to Use the Camera

EXPOSURE SETUP	
1.BRIGHTNESS 25
2.SHUTTER	MANUAL ↕
3.AGC	HIGH
4.SENS-UP	AUTO ↕
5.RETURN	↕

- **SHUTTER** : You can select either auto or manual shutter.
 - A.FLK : Select this when you experience picture flicker, which can happen when there is a clash with the frequency of the installed lighting.
 - ESC : Select this to control the shutter speed automatically. If ESC is selected, the shutter speed is automatically controlled depending on the ambient illumination of the subject.
 - MANUAL : You can control shutter speed manually.
(NTSC : 1/60~1/120,000, PAL : 1/50~1/120,000)

- Note**
- When you use a DC lens, set the shutter mode to A.FLK if colour rolling occurs.
 - When the SHUTTER is set to ESC after selecting the Internal Synchronization Type, the picture may become unstable if the camera faces a bright fluorescent light. Therefore, take care when choosing the installation position.
 - When the SHUTTER is set to MANUAL or A.FLK mode, SENS-UP will be disabled.

- **AGC(AUTO GAIN CONTROL)** : The higher the gain level, the brighter the screen - but the higher the noise.
 - OFF : Deactivates the AGC function.
 - LOW : Allows automatic gain control from 5.3dB to 32dB.
 - HIGH : Allows automatic gain control from 5.3dB to 37dB.
- **SENS-UP** : When it is night or dark, the camera automatically detects the light level and maintains a clear picture if this mode is activated.
 - OFF : Deactivates the SENS-UP function.
 - AUTO : Activates the SENS-UP function.
- **RETURN** : Select this to save the changes in the EXPOSURE menu and return to the SETUP menu.

- Note**
- If you press the SET button in 'AUTO' mode, You can adjust brightness by increasing or decreasing the shutter speed. (X2~X512)
 - Note that the higher the zoom level, the brighter the screen, but the more likely it is that an after-image will appear.
 - Although Noise, Spots, and Whitish symptoms may occur in SENS-UP operation when the zoom level is increased, this is normal.

White Balance (White Bal.)

Use the White Balance function to adjust the screen colour.

1. When the SETUP menu screen is displayed, select 'White Bal.' by using the Up and Down buttons so that the arrow indicates 'White Bal.'
2. Select a desired mode using the Up and Down buttons.

MAIN MENU	
1.LENS	DC ↕
2.EXPOSURE	↕
3.WHITE BAL	ATW
4.SSDR	ON ↕
5.BACKLIGHT	OFF

- ※ Select one of the following 5 modes, as appropriate for your purpose.
- **ATW** : Select this when the colour temperature is between 1,700°K and 11,000°K.
 - **OUTDOOR** : Select this when the colour temperature is between 1,700°K and 11,000°K. (sodium light inclusion)
 - **INDOOR** : Select this when the colour temperature is between 4,500°K and 8,500°K.
 - **MANUAL** : Select this to fine-tune White Balance manually. Set White Balance first by using the ATW or AWC mode. After that switch to MANUAL mode, fine-tune the White Balance and then press the SET button.
 - **AWC**→**SET** : To find the optimal luminance level for the current environment, point the camera towards a sheet of white paper and press the Function Setup switch. If the environment changes, readjust it.

How to Use the Camera

Note

- White Balance may not work properly under the following conditions. In this case select the AWC mode.
 - When the colour temperature of the environment surrounding the subject is out of the control range (e.g. clear sky or sunset).
 - When the ambient illumination of the subject is dim.
 - If the camera is directed towards a fluorescent light or is installed in a place where illumination changes dramatically, the White Balance operation may become unstable.

SSDR (Super Dynamic Range)

SSDR illuminates darker spots of an image while retaining the same light level for brighter spots to even out the overall brightness of images with high contrast between bright and dark spots.

MAIN MENU	
1.LENS	DC ↕
2.EXPOSURE ↕	
3.WHITE BAL	ATW
4.SSDR	ON ↕
5.BACKLIGHT	OFF

- When the SETUP menu screen is displayed, select 'SSDR' by using the Up and Down buttons so that the arrow indicates 'SSDR'.
- Use the Left/Right buttons to change the SSDR level in the sub menu according to the contrast between bright and dark spots.

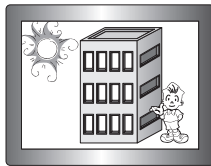

SSDR ON

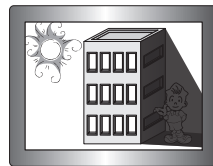

SSDR OFF

BACKLIGHT

This camera is designed so that it delivers a distinctive subject and background at the same time, even when the subject is in backlight, unlike conventional cameras, by adopting a proprietary W-V DSP chip.

- When the SETUP menu screen is displayed, select 'BACKLIGHT' by using the Up and Down buttons so that the arrow indicates 'BACKLIGHT'.

MAIN MENU	
1.LENS	DC ↕
2.EXPOSURE ↕	
3.WHITE BAL	ATW
4.SSDR	ON ↕
5.BACKLIGHT	OFF

- Select a desired mode using the Left and Right buttons depending on the camera purpose.

- BLC** : Enables a user to directly select a desired area from a picture, and to view the area more clearly.

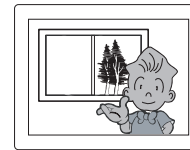

BLC ON

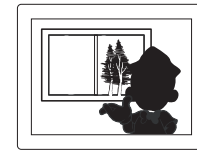

BLC OFF

- HLC (High Light Compensation)** :

If the scene contains extremely brightly light areas such as; from car headlight, the light can mask out much of the on-screen detail. Use HLC feature to remove these exceptionally brightly light areas to allow detail such as car number plates to become visible.

- LEVEL : Adjust level of the HLC function.
- LIMIT : Enable to change the operating condition.
- MASK COLOUR/TONE : Change the colour / brightness of the masking area. (Black, Red, Blue, Cyan, Magenta)
- TOP/BOTTOM/LEFT/RIGHT : Adjust the area to be enhanced.

How to Use the Camera



HLC ON

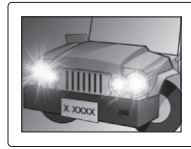

HLC OFF

- **OFF** : Not being used

3. Select a desired mode using the Left and Right buttons and press the SET button.
 - Select 'BLC' to adjust the area to be enhanced then adjust the level.
 - **HLC** : Enable the user to change the level, limit, mask colour/tone and area.

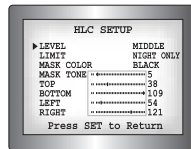
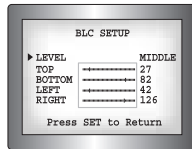

Note

- For effective license plate observation, it needs minimum illumination and fast shutter speed more than 1/200sec.
- Because there can be a difference in the effectiveness of HLC according to the amount of light area in the screen, optimize the installation angle for the best HLC performance.
- When dark, the HLC is only activated when a bright light exceeding a specific size.in NIGHT ONLY mode.
- The HLC is not activated in day light or when bright light is not present at night.in NIGHT ONLY mode.

DNR3

This function reduces the background noise in a low luminance environment.

1. When the SETUP menu screen is displayed, select 'DNR' by using the Up and Down buttons so that the arrow indicates 'DNR'.

MAIN MENU

1.LENS	DC
2.EXPOSURE	
3.WHITE BAL	ATW
4.SSDR	ON
5.BACKLIGHT	OFF
6.DNR3	ON
7.DAY/NIGHT	COLOR

2. Select a desired mode using the Left and Right buttons.

- **OFF** : Deactivates DNR. Noise is not reduced.
- **ON** : Activates DNR so that noise is reduced.

3. Set the DNR mode to 'ON' and press the SET button. Then you can adjust the noise reduction level.

Note

- You cannot set the DNR to 'ON' or 'OFF' when the AGC mode of the EXPOSURE menu is 'OFF'.
- When adjusting the noise reduction level in the DNR mode, remember that the higher the level set, the more the noise level will be reduced, as will the brightness of the image.

DAY/NIGHT

You can display pictures in colour or black and white.

1. When the SETUP menu screen is displayed, select 'DAY/NIGHT' by using the Up and Down buttons so that the arrow indicates 'DAY/NIGHT'.

MAIN MENU

1.LENS	DC
2.EXPOSURE	
3.WHITE BAL	ATW
4.SSDR	ON
5.BACKLIGHT	OFF
6.DNR3	ON
7.DAY/NIGHT	COLOR

■ How to Use the Camera

2. Select a desired mode using the Left and Right buttons according to the picture display you want.

● **COLOUR** : The picture is always displayed in colour.

● **B/W** : The picture is always displayed in black and white.
You can turn on or off the burst signal on B/W mode.

● **AUTO** : The mode is switched to 'Colour' in a normal environment, but switches to 'B/W' mode when ambient illumination is low.
To set up the switching time for AUTO mode, press the SET button.
You can turn on or off the burst signal on B/W mode.

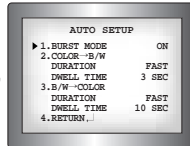

- **DWELL TIME** : You can select the duration time about changing the day/night mode. → 5s, 7s, 10s, 15s, 20s, 30s, 40, 60s

● **EXTERN** : This mode allows you to apply a desired filter to external signals.



Note

- When using a Video Auto Iris Lens, if you set the lens level to low, automatic switching between Colour and Black & White may not occur.
- When AGC in the EXPOSURE menu is 'OFF', the exchange between DAY mode and NIGHT mode operates as like selecting 'COLOUR' mode.

SPECIAL

1. When the SETUP menu screen is displayed, select 'SPECIAL' by using the Up and Down buttons so that the arrow indicates 'SPECIAL'.

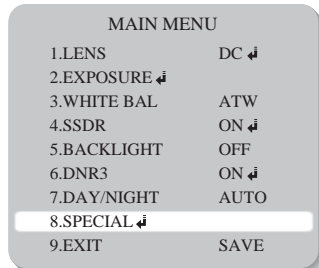

2. Select a desired mode using the Up and Down buttons.

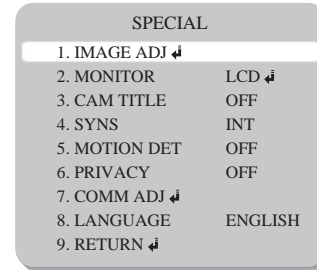

● **IMAGE ADJ.** :

- 1) When the SETUP menu screen is displayed, select 'IMAGE ADJ.' by using the Up and Down buttons so that the arrow indicates 'IMAGE ADJ'.
- 2) Select a desired mode using the Up and Down buttons.

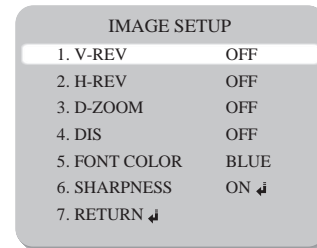

- **V-REV** : You can flip the picture vertically on the screen.
- **H-REV** : You can flip the picture horizontally on the screen.
- **D-ZOOM** : You can use a digital zoom of x1 ~ x16.
- **DIS** (Digital Image Stabilizer) : This function mitigates any picture movement due to external factors such as wind.

How to Use the Camera

Note

- As the DIS function uses the digital zoom the camera's resolution will decrease.
 - DIS doesn't operate when background illumination is too low.
 - DIS doesn't operate when object pattern is monotonic as like sky or white wall.
- FONT COLOUR :** You can change the OSD font colour. (White, Yellow, Green, Red, Blue)
 - SHARPNESS :** As you increase this value, the picture outline becomes stronger and clearer. Adjust this value appropriately depending on the sharpness of the picture.
 - RETURN :** Select this to save the settings for the IMAGE ADJ. menu and to return to the SETUP menu.

Note

- When the V-REV or H-REV mode is enabled, the text on the screen does not flip.
- If you increase the SHARPNESS level too high, the picture may become distorted or noise may appear.

- MONITOR :** Please change the settings value of video appropriate to your monitor.

- LCD :** Please select this menu item when using an LCD monitor.
- CRT :** Please select this menu item when using a CRT monitor.
- USER :** Please use this menu item when using a monitor other than standard ones. You can change the gamma, PED level, and colour gain in the sub menus.

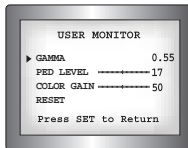

- CAM TITLE :** If you enter a title, the title will appear on the monitor.
 - If the SPECIAL menu screen is displayed, use the Up and Down buttons so that the arrow indicates 'CAM TITLE'.
 - Set it to 'ON' by using the Left and Right buttons.
 - Press the SET button.

- Use the 4 direction buttons to move to a desired letter and select the letter by pressing the SET button. Repeat this to enter multiple letters. You can enter up to 15 letters.

- Enter a title, move the cursor to 'POS' and press the SET button. The entered title appears on the screen. Select the position to display the title on the screen by using the 4 direction buttons and press the SET button. When the position is determined, select 'END' and press the SET button to return to the SPECIAL menu.

CAMERA TITLE SETUP

```

ABCDEF GHI J KLM
NOPQRS TUVWXYZ
abcdefghijklmnop
123456789
→ ← CLR POS END
  
```



Note

- When the CAM TITLE menu is 'OFF', no title will be displayed on the monitor screen even if you enter one.
- Only English is available in this mode.
- If you move the cursor to CLR and press the SET button, all the letters are deleted. To edit a letter, change the cursor to the bottom left arrow and press the SET button. Move the cursor over the letter to be edited, move the cursor to the letter to be inserted and then press the SET button.

- SYNC :** In areas where the supply is at 60Hz, you can synchronize the output phase of multiple cameras using the power synchronization function (Line-Lock) without using a synchronization signal generator.
 - INT :** Internal Synchronization Type
 - LL :** Power Synchronization Type, Line-lock
 - Press the Function Setup switch.
 - You can select a desired phase from 0 to 359 when select 'phase'.



Note

- When using AC power at 60Hz frequency, you can use the L/L type synchronization.
- When the power is DC 12V, the SYNC menu is fixed to the 'INT' mode.

How to Use the Camera

MOTION DET :

This product has a feature that allows you to observe movement of objects in 8 different areas on the screen, and the words 'MOTION DETECTED' appear on the screen when movement is detected. you can monitor activity more efficient.

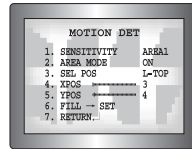

- 1) When the SPECIAL menu screen is displayed, press the Up and Down buttons so that the arrow indicates 'MOTION DET'.
- 2) Set up the mode using the 4 direction buttons.
 - SENSITIVITY : You can select up to 8 MD areas. When SENSITIVITY number is high, motion detection sensitivity is increased to recognize even small movement.
 - AREA MODE : Determines whether to use the MD area selected in SENSITIVITY.
 - SEL POS : Determines which of the 4 vertices of each MD area is to be used.
 - XPOS : Determines the coordinate of the horizontal axis for SEL POS.
 - YPOS : Determines the coordinate of the vertical axis for SEL POS.
 - FILL→SET : Fills in a selected MD area. Fills in a selected MD area. The colour of filling is sequentially selected as brown, orange, blue, cyan, yellowish green, yellow and red.
 - RETURN : Select this to save the MOTION DET menu settings and return to the SPECIAL menu.

- **PRIVACY** : Mask an area you want to hide on the screen.

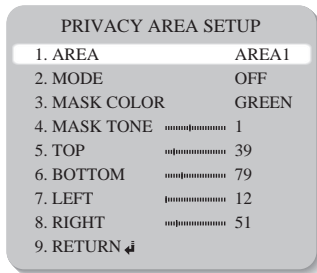

- 1) When the SPECIAL menu screen is displayed, press the Up and Down buttons so that the arrow indicates 'PRIVACY'.
- 2) Set up the mode using the 4 direction buttons.
 - AREA SEL : You can select up to 12 PRIVACY areas.
 - MODE : Determines whether to use the area selected in the AREA SEL.
 - MASK COLOUR : Determine area colour. You can select Green, Red, Blue, Black, White, Gray.
 - MASK TONE : Adjust the brightness of MASK COLOUR.
 - TOP/BOTTOM/LEFT/RIGHT : Adjust the size and position of the selected area.
 - RETURN : Select this to save the PRIVACY menu settings and return to the SPECIAL menu.

COMM ADJ (Communication Adjustment) :

This function sets up the camera communication status when controlling the camera through an external control device.

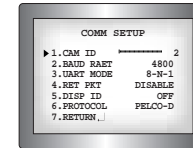

- ① When the SPECIAL menu screen is displayed, press the Up and Down buttons so that the cursor points to 'COMM ADJ'.
- ② Set up the mode using the 4 direction buttons.
 - CAM ID : Determines the camera's identification number. (between 0 and 255).
 - BAUD RATE : Select 2400/4800/9600/19200/38400/57600 bps.
 - UART MODE : Select NONE, EVEN or ODD for the parity bits.
 - RET PKT : Determines whether to send a command back to the controller device when a communication control command is sent to the camera.
 - DISP CAM ID : Display the camera title on the top left corner of the screen.
 - PROTOCOL : STW(SPD), PELCO-D, PELCO-P, SEC, BOSCH HONEY WELL, VICON, PANA

■ How to Use the Camera

- **LANGUAGE** : You can select the menu language according to your requirements.
- **RETURN** : Select this to save the SPECIAL menu settings and return to the MAIN SETUP menu.

EXIT

Select a desired EXIT mode using the Left and Right buttons depending on the camera purpose.

- **SAVE** : Save the current settings and exit the MAIN SETUP menu.
- **NOT SAVE** : Do not save the current settings and exit the MAIN SETUP menu.
- **RESET** : Resets the camera settings to the factory defaults. Language and Monitor settings are not initialized.

Troubleshooting ■

If you have trouble operating your camera, refer to the following table. If the guidelines do not enable you to solve the problem, contact an authorized technician.

Problem	Solution
Nothing appears on the screen.	<ul style="list-style-type: none">• Check the power connections.• Check the VIDEO signal line connection.
The image on the screen is dim.	<ul style="list-style-type: none">• Make sure the lens is clean. Clean the lens with a soft clean lint free cloth.• Adjust the monitor contrast & brightness controls.• Re-position the camera if necessary.
The image on the screen is dark.	<ul style="list-style-type: none">• Adjust the contrast control of the monitor.• If you have an intermediate device, set the 75Ω/ Hi-z properly.
The camera is not working properly, and the surface of the camera is hot.	<ul style="list-style-type: none">• Check that an appropriate power source is connected to the camera.
The DAY/NIGHT menu does not work.	<ul style="list-style-type: none">• Check that AGC in the EXPOSURE menu is set to 'OFF'.
The SENS-UP function does not work.	<ul style="list-style-type: none">• Check that AGC in the EXPOSURE menu is not set to 'OFF'.• Check that SHUTTER in the EXPOSURE menu is not set to 'A.FLK' or 'MANUAL'.
The Motion Detection function does not work.	<ul style="list-style-type: none">• Check that MOTION DET in the SPECIAL SETUP is not set to 'OFF'.
Colour is not correct.	<ul style="list-style-type: none">• Check the WHITE BAL settings in the SETUP menu.
The screen flickers continually.	<ul style="list-style-type: none">• Check that the camera isn't facing toward a bright light source, such as the sun.

■ Specifications

MEMO ■

ITEM	NTSC	PAL
Power Consumption	DC12V 160mA	
Image Sensor	SONY 1/3" Super HAD High Sensitivity Colour CCD	
Total Pixels	811(H) x 508(V)	795(H) x 596(V)
Effective Pixels	768(H) x 494(V)	752(H) x 582(V)
Scanning System	2:1 Interlace	
Synchronization	INT	
Frequency	Horizontal: 15.734 KHz, Vertical: 59.94 Hz Horizontal: 15.625 KHz, Vertical: 50.00 Hz	
H.Resolution	600 TV lines	
S/N	52dB (AGC Off, Weight ON)	
Min. Illumination	0.15Lux (40 IRE)	
White Balance	ATW / AWC / MANUAL(1700°K ~ 11,000°K) / INDOOR / OUTDOOR	
Shutter Speed	1/60 ~ 1/120,000 sec	1/50 ~ 1/120,000 sec
Sens-up	AUTO / OFF (Selectable x2 ~ x512)	
Gain Control	LOW / HIGH / OFF	
DNR	ON / OFF (1~32 Level)	
Motion Detection	ON / OFF (8 Zone, ALARM Output)	
Privacy Function	ON / OFF (12 Zones)	
V-REV	ON / OFF	
H-REV	ON / OFF	
Sharpness	ON/OFF (Level Adjustable)	
Day&Night	COLOUR / B/W / AUTO / EXTERN	
DIS	ON / OFF	
Digital Zoom	ON / OFF (x16)	
Blemish Compensation	256 point (Even 128 Point, Odd 128 Point)	
Lens Mount	CS Mount (Easy Focus type) (C Mount is mountable by using adaptor)	
Back Focus Adjustment	Manual	
Operating temperature/Humidity	-10°C to + 50°C / 30% to 80% RH	
Storing Temperature/Humidity	-20°C to + 60°C / 20% to 90% RH	
Weight	Approx. 180g	

■ MEMO

A large rectangular area defined by a dotted line, intended for writing a memo.



Model : C6351/12

Ultra High Resolution Day&Night Camera

Instruction Guide



GENIE CCTV LTD.

CCTV House, City Park, Watchmead, Welwyn Garden City, Hertfordshire, AL7 1LT

Tel : +44 (0) 1707 330541 Fax : +44 (0) 1707 330543

www.geniecctv.com



Edition. GN-JANUARY 2013