

BT1 Door Entry Telephone Interface

The BT1 Telephone interface offers the convenience of operating a door entry system from an existing BT style telephone without interfering with its normal usage. Most domestic tone-dial telephones are compatible with the BT1 including cordless DECT telephones which are of great benefit to those people with limited mobility.

Operation

The BT1 interface appears transparent to the phone line, even if the BT1 is not powered.

When a call is made from the Entrance panel the phone will ring for a maximum of 30 seconds, a ringing tone will be heard at the panel. When the phone is picked up the visitor can converse with the resident and operate a lock release by pressing the **1** key to allow access. The door will be released for 3 seconds, during which time beeps will be heard at the entrance and at the phone.

The operations below require a connection to an external phone line/network:

The resident can activate the panel without a visitor initiating the call by picking up the handset and pressing *****, then **8**. The resident can then talk to anybody at the entrance and release the door with the **1** key if necessary.

If a resident is conversing with a visitor and an external phone call is received a ring tone will be heard in the entrance panel and phone. Pressing the ***** key switches between visitor and external phone line. When the visitor is selected the phone at the end of the other line will hear an 'on hold' melody. When the phone line is selected a short warning beep is heard (or when calling from the door and on a phone call). Pressing **1** when the visitor is selected will release the door.

Connection to the phone line

It is illegal to tamper with, or wire into, the primary master socket from the telephone line coming into a house or office.

The BT1 must be connected between this primary master socket and any phones, FAX, etc inside the office/house. Connection to the primary master socket must be made using the plug provided. A new master socket (not supplied) can then be wired to the BT1 using the diagram overleaf.

A maximum of 3 phones/devices (equivalent to a REN of 3) can be connected to the new master socket.

Broadband / Help Systems

Any equipment/system requiring a permanent connection such as Broadband or Help/Alarm systems must be connected to the original Master socket, NOT to the new Master socket or BT1 output (L+/-). A Micro-filter will be needed.

Typical Wiring

NOTE

Use 0.5mm diameter twisted-pair telephone cable (e.g. CW1308), unless otherwise specified

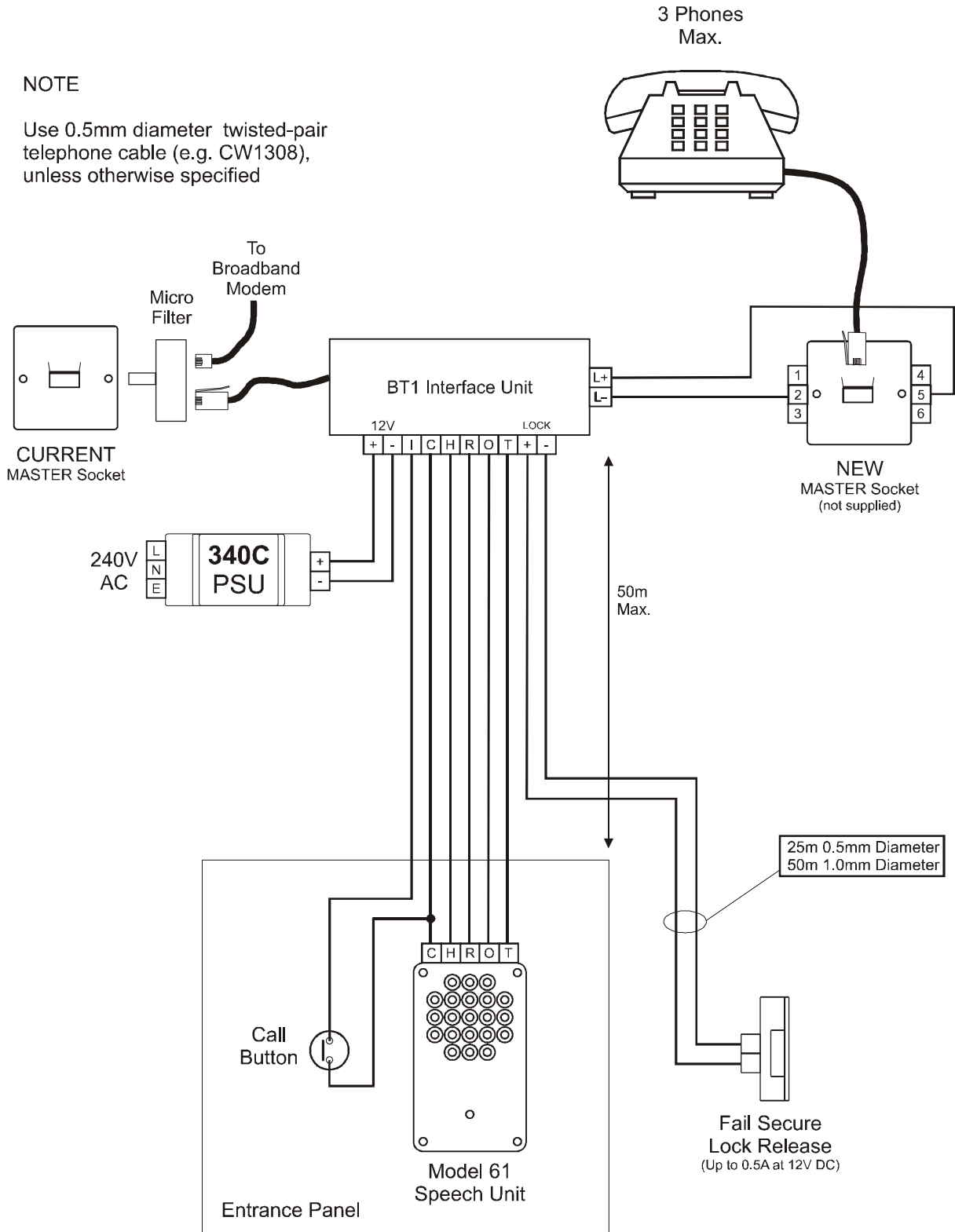

2 Entrance 1 way wiring to the BT1 Telephone Interface

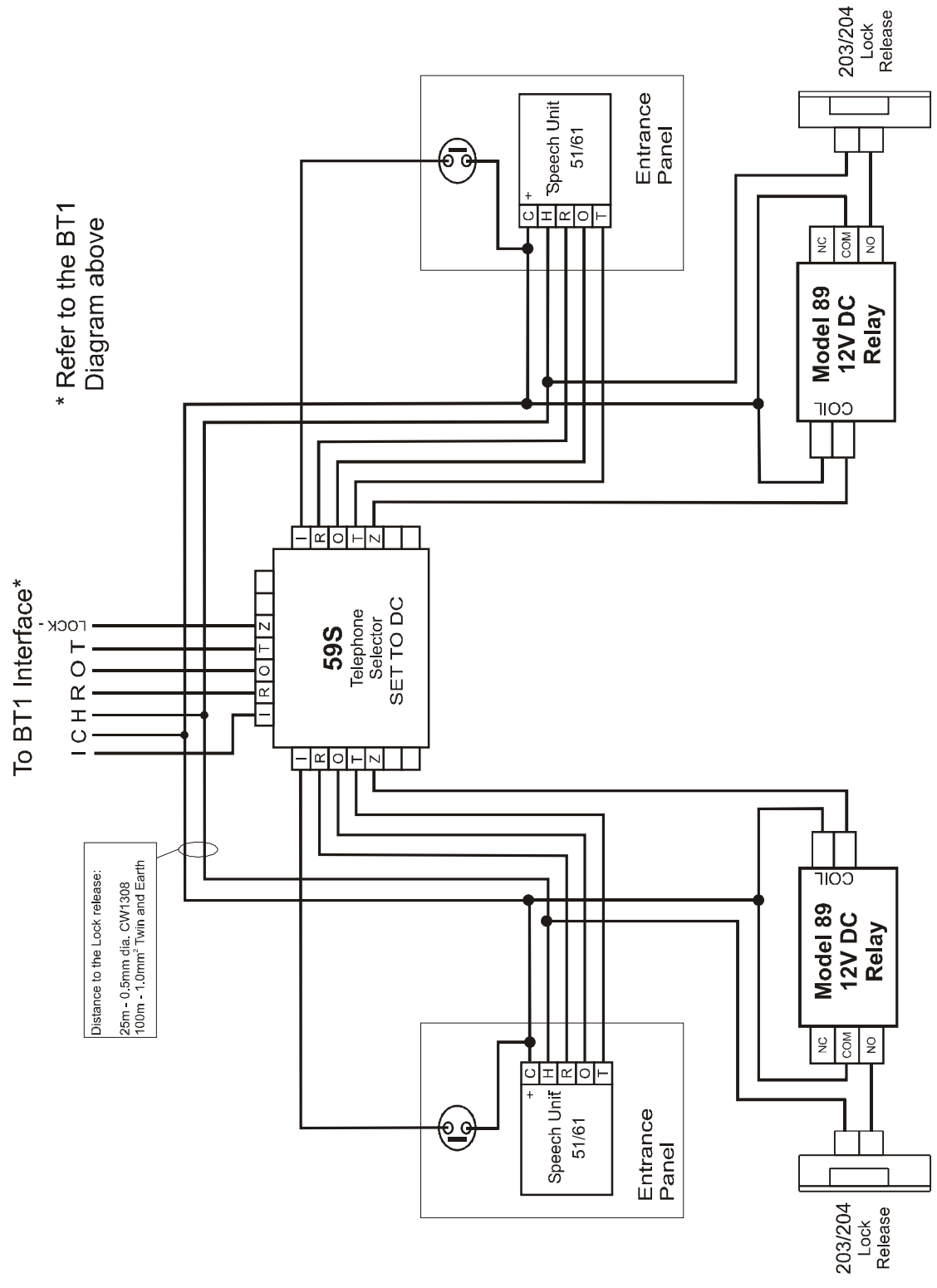

Systems with PAX1 Proximity Reader

NOTE

Use 0.5mm diameter twisted-pair telephone cable (e.g. CW1308), unless otherwise specified

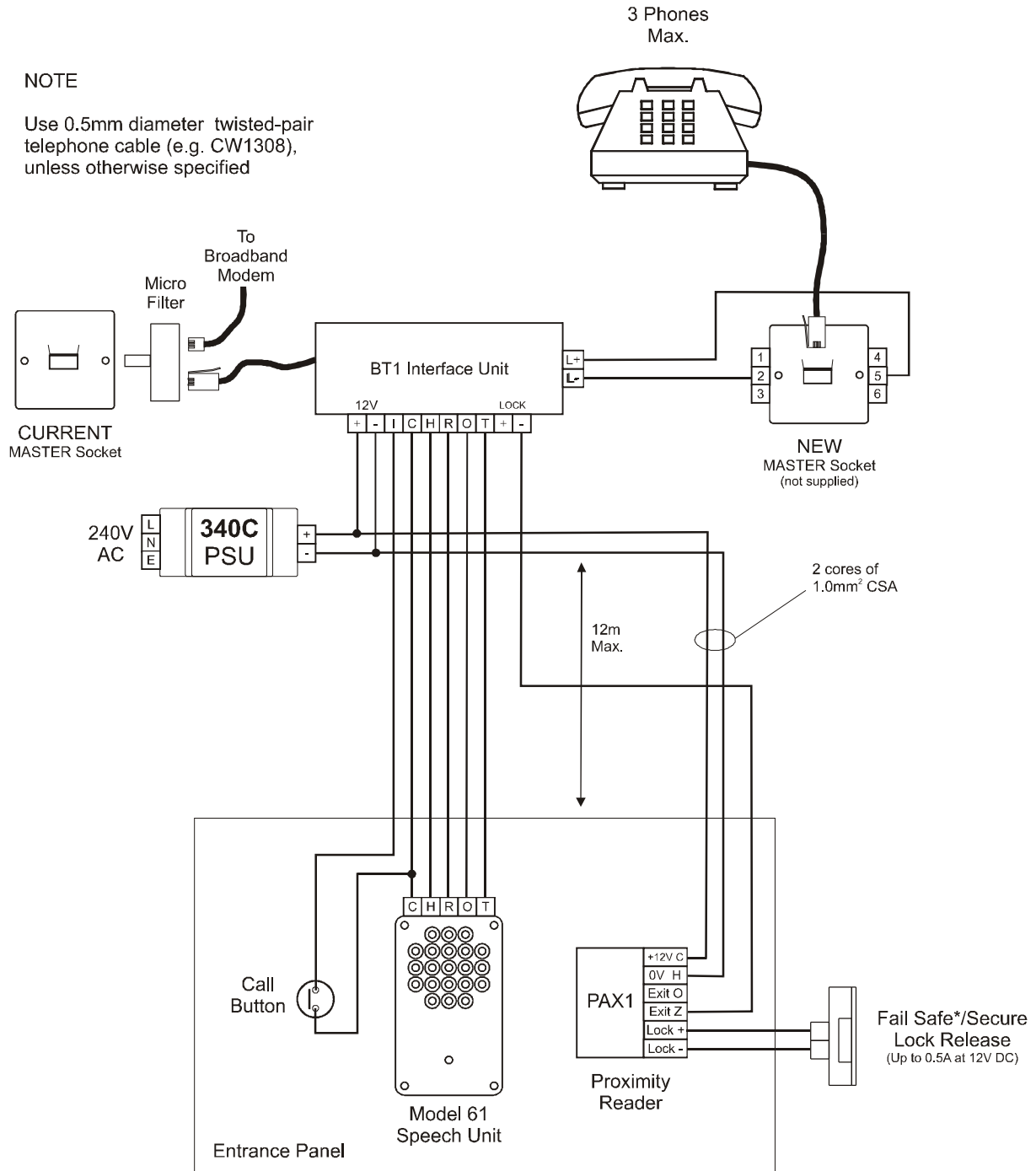

*** If a Maglock is used, a suitable transient suppressor must be fitted directly across the Maglock.**

BT1 Systems with:

200/CK200 Coded Access Control

In this case the Lock should be connected to the 200 Control unit and the Lock – terminal on the BT1 should be connected to the EXIT + terminal on the 200 Controller to trigger lock operation. Connect the negative of any Power Supplies together to provide a common reference. Follow the BellCode manual to wire the Coded Keypad.

C106/CP106-n Coded Access Control

In this case the Lock should be connected to the C106 Keypad and the Lock – terminal on the BT1 should be connected to the EXIT + terminal on the C106 to trigger lock operation. Connect the negative of any Power Supplies together to provide a common reference.

DDA Audio Entrance Panel

Wire up using the 'Typical wiring' connecting to the C, H, R, O, T on the DDA PCB (in the entrance panel) not the speech unit. Connect Z on the DDA PCB to 'Lock-' on the BT1. Do not connect anything to Lock +/- on the DDA PCB.

PABX Internal Exchange

The interface may also be connected onto a telephone switchboard via a dedicated analogue trunk line input, NOT an extension connection. Please note, operation cannot be guaranteed with every PABX available. The connection should be made by a competent telephone engineer. The BT1 generates line and ring voltages itself.



bell
system
(Telephones) Ltd

This product complies with European Directive 89/336/EEC on ElectroMagnetic Compatibility and Low Voltage Directive 73/23/EEC.

Bell System (Telephones) Ltd.
Presley Way, Crownhill, Milton Keynes MK8 0ET
Tel: 01908 261106 FAX: 01908 261116
email: sales@bellsystem.co.uk or technical@bellsystem.co.uk
website: www.bellsystem.co.uk