

# **Bell System (Telephones) Ltd.**

***bellissimo***

**Video Door Entry System**

**2-72 Way**

**Installation & Operation Manual**

**This manual applies to the following: –**

**BSD8/72 2 to 72 Way Door Controller – Version 2 Build 6 onward**

**BSC4 Video Controller – Version 2 Build 4 onward**

**BS Colour Videophone – Version 3**

**BSA Audio Phone – Version 1**

# **bell*issimo* 2-72 Way Video Entry System**

# ***bellissimo* 2-72 Way Video Entry System**

## **TABLE OF CONTENTS**

<b>TABLE OF CONTENTS</b> .....	<b>3</b>
<b>INTRODUCTION</b> .....	<b>4</b>
DESCRIPTION .....	4
MAIN FEATURES .....	4
<i>BELLISSIMO</i> COLOUR VIDEOPHONE .....	5
<b>BASIC SYSTEM OPERATION</b> .....	<b>6</b>
<b>DESIGN CONSIDERATIONS</b> .....	<b>9</b>
EQUIPMENT LIST .....	9
OPTIONS .....	9
POWER SUPPLY REQUIREMENTS .....	10
CABLE SPECIFICATION .....	12
CABLE DISTANCES – COLOUR VIDEOPHONES.....	13
<b>INSTALLATION &amp; COMMISSIONING</b> .....	<b>14</b>
CHECKLIST .....	14
WIRING .....	14
COMMISSIONING .....	16
BSD8/72 DOOR CONTROLLER SWITCH SETTINGS .....	17
BSD8/72 DOOR CONTROLLER JUMPER SETTINGS .....	19
BSC4 VIDEO CONTROLLER SETTINGS.....	20
BS VIDEOPHONE SWITCH SETTINGS .....	22
<b>TROUBLESHOOTING</b> .....	<b>23</b>
QUICK FAULT REFERENCE.....	23
<b>SPECIFICATIONS</b> .....	<b>26</b>
<b>DIAGRAM A – 2-72 WAY BASIC SYSTEM OVERVIEW CABLING</b> .....	<b>28</b>
<b>DIAGRAM B – LARGE SYSTEM OVERVIEW</b> .....	<b>29</b>
<b>DIAGRAM C – BSD8 PCB DETAIL</b> .....	<b>30</b>
<b>DIAGRAM D – 2-72 WAY BASIC SYSTEM WIRING DETAIL</b> .....	<b>31</b>
<b>DIAGRAM E – 2-72 WAY MULTIPLE ENTRANCE WIRING DETAIL</b> .....	<b>32</b>
<b>DIAGRAM F – EXTENSION VIDEOPHONE WIRING</b> .....	<b>33</b>
<b>DIAGRAM G – VIDEOPHONE LOCAL POWER WIRING</b> .....	<b>34</b>
<b>DIAGRAM H – VIDEOPHONE CONNECTIONS</b> .....	<b>35</b>
<b>DIAGRAM I – OPTION DETAILS</b> .....	<b>36</b>
<b>DIAGRAM J – 2-72 WAY ADDITIONAL DDA WIRING</b> .....	<b>37</b>
<b>DIAGRAM K – <i>BELLISSIMO</i> COMBINED SYSTEM CONNECTIONS</b> .....	<b>38</b>
<b>DIAGRAM L – ACT PROXIMITY TO <i>BELLISSIMO</i> CONNECTIONS</b> .....	<b>39</b>
<b>SAFETY INFORMATION AND DECLARATIONS</b> .....	<b>42</b>

# bellissimo 2-72 Way Video Entry System

## Introduction

### Description

A *bellissimo* video door entry system consists of a door panel, positioned at the entrance of a building, video telephones (videophone), placed inside of the building for the convenience of the occupants and a power supply and controller which are usually located inside an electrical cupboard. The door panel comprises of a two-way speech unit, a camera and several push buttons – one of which must be depressed by a visitor to initiate a call. The videophone, which rings in response, allows a two-way conversation via a handset whilst the caller can be observed through the integral display. The operator can selectively allow visitors access to the building by pressing a button on the videophone and so electrically releasing the door.

The *bellissimo 2-72-way* Video Door Entry System is suitable for any building requiring multiple push buttons at the entrance, such as blocks of flats or multiple offices. For buildings requiring a single push button at the entrance, such as houses, individual flats and offices, please refer to the “*bellissimo 1-way* Video Entry System” manual. For a digital panel with display, refer to the *bellissimo Digital* System.

The *bellissimo* “2-72-way” system is supplied with a dedicated door controller, for each entrance, and a video controller for every four videophones. The basic system supports 1 videophone per call button, and up to 3 extension videophones (more with additional power supplies). Multiple entrances can be supported with the addition of one panel and one door controller for each entrance.

### Main Features

- Cat5 cable throughout; no co-ax required!
- 3.5” Flat screen high resolution TFT colour display.
- High resolution CCD colour day/night camera with infrared lamps.
- 12V d.c. operation
- High quality full-duplex speech amplifier.
- Automatic picture display while ringing.
- Ringer mute function.
- Ringer volume control.
- Fail safe or fail secure lock releases and magnetic locks (maglock).
- Lock release timer.
- Tradesman facility (optional).
- Facility for exit button and/or fire switch.
- Door open indication.
- Second camera option.
- Up to 3 extension videophones per flat.
- DDA panel options.
- Multiple entrances supported.

# bellissimo 2-72 Way Video Entry System

## bellissimo Colour Videophone

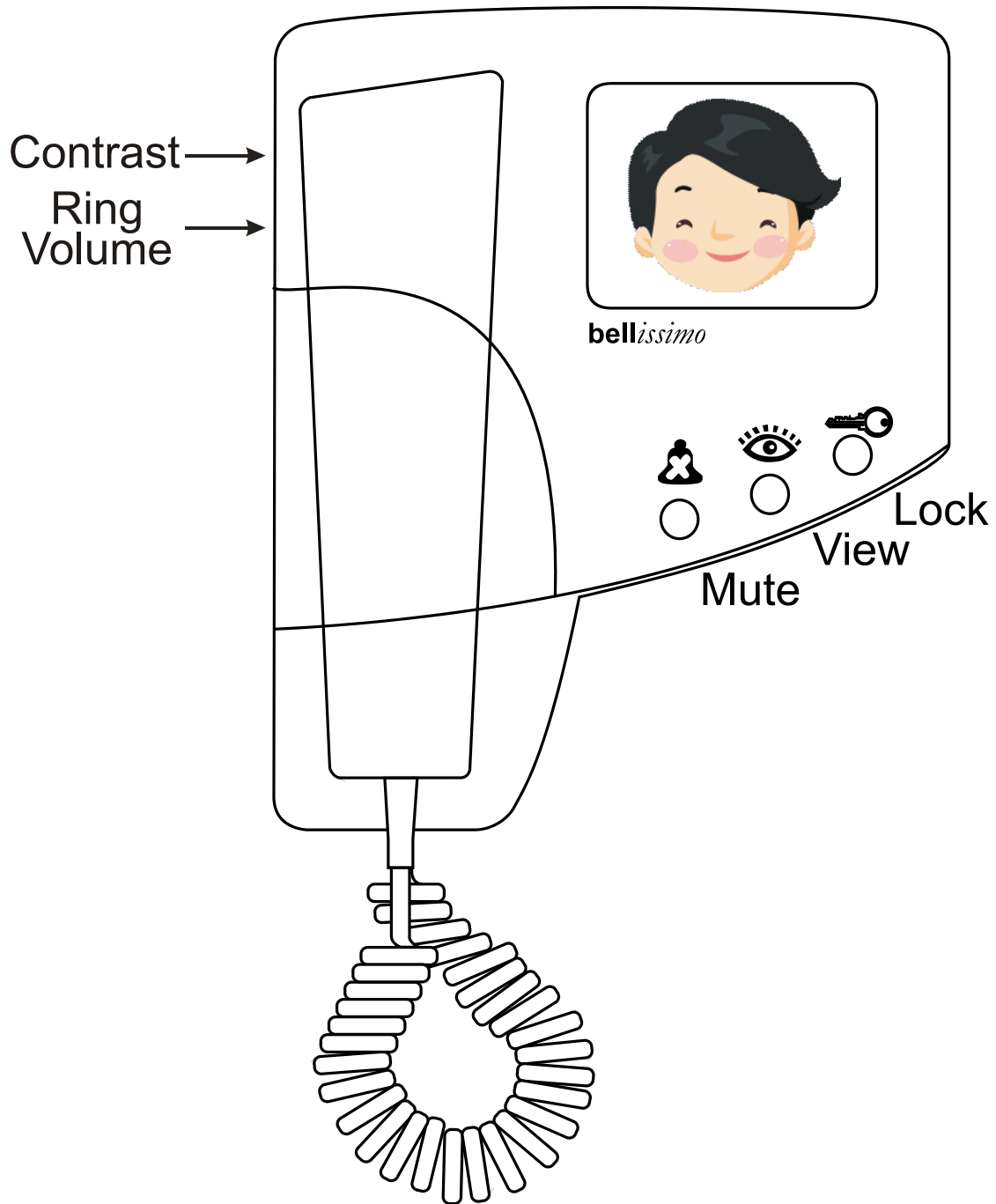

Button	Lamp	Steady	Flashing
<b>Mute On/Off</b>	Red	Videophone is muted	Videophone is off-hook
<b>View / Camera select</b>	Amber	Call in progress	Ringing
<b>Lock</b>	Green	Door is open	Press to release lock

# bellissimo 2-72 Way Video Entry System

## Basic System Operation

### Call sequence

When the **call** button is pressed at the entrance panel it causes the videophone to ring and the amber **view** lamp to flash. The videophone will continue to ring for up to 30 seconds or until the resident responds by picking up the handset. At this time the resident can freely converse with the visitor whose image is now displayed on the videophone; at the same time the green **lock** lamp will flash to highlight the **lock** button.

The call may be terminated by replacing the handset or more usually by pressing the **lock** button first to allow the visitor access through the entrance; the speech and picture will persist for a further 3 seconds while the door is being released.

### Videophone Controls

The diagram in the introduction shows the standard colour monitor and its controls. The default setting is ringer volume midway and contrast maximum (slide finger to top).

### Auto Display

When 'Auto Display' mode is selected the picture will come on while the videophone is ringing, otherwise the picture will only come on when the call is answered. Auto Display mode is usually pre-selected at installation and generally only one videophone per flat should be set in this mode (see 'Extension Videophones' below).

### Call Mute

The resident can mute the ringing sound in the videophone when they do not wish to be disturbed. Call mute is activated by pressing the **mute** button on the videophone, which then illuminates in red as a reminder. The handset must be on the hook for this to work. Pressing the **mute** button a second time will disengage the mute function. During installation it is possible to set a time limit for the mute function in various values from 2 minutes up to 10 hours, indefinitely or disabled. When this time period has elapsed the mute function will automatically disengage. (See 'mute timer', page 22).

Mute only stops the audible ring, but the amber **view** light will still flash and all other functions work normally. Mute will continue for the preset time even if a call is answered.

### Silent viewing

When the videophone is ringing the resident can press the **view** button to answer the call instead of lifting up the handset; this will stop the videophone ringing and enable them to view the visitor for up to 60 seconds or until the **lock** button is pressed to release the door. Silent viewing can be 'normalised' at any time by picking up the handset and conversing with the visitor as described above.

### Door Status Indication

The green **lock** lamp on the videophone will illuminate to warn the resident that a door has been left open following a call. This feature requires a door monitor contact to be fitted.

### Call Privacy

Once a call has been answered by one videophone no other videophones may join in, view or listen to the call. If another videophones handset is picked up, or the **view** button is pressed, the videophone will not activate.

# **bellissimo 2-72 Way Video Entry System**

## **User Activation (CCTV Mode)**

User activation is a feature of the *bellissimo* 1 way system and is not available on multi-way systems. User activation is generally not recommended on larger systems as the conflicting demands of residents and callers can result in confusion and erroneous fault reports.

## **Cameras**

The door controller has the capability of using one or two cameras, for instance a second panel camera for DDA or a 'third party' 'CCTV' camera located to offer a different entrance viewpoint. Pressing the **view** button will alternate the view between camera 1 and camera 2 (if enabled).

Note. The camera to controller wiring has termination options which allow for connections to other video equipment. See the Options Diagram on page 36 for details.

## **Extension Videophones**

Additional videophones may be added to each 'flat'. The number of extensions is limited only by power supply considerations. All videophones for that 'flat' will ring when called however typically only the master unit will display a picture while ringing. Once the master or extension videophone is 'picked-up' the picture will display on that unit alone.

## **Lock Type**

The door controller supports both fail-secure and fail-safe locks including magnetic locks of up to 1A rating. The lock time may be set between 3 and 20 seconds. (See 'Lock Operating time' and 'Lock Type' on page 18.

## **Exit Button and Fire Switch**

An input is provided for an exit button, which can be installed on the inside of the door and allow residents to exit freely. Momentary operation of this button will operate the lock release for the programmed lock time. A Fire switch or other override device may use the same input to hold the door open indefinitely. Note. Fail secure locks must be continuously rated.

## **Trades Facility**

Use of a time clock in conjunction with a trades button will allow free access during the programmed time(s).

## **DDA Functionality**

The *bellissimo* video system has a range of options for entrance panels to help meet the requirements of the Disability Discrimination Act (DDA), including Illuminated Tactile buttons, reassurance tones and LED indicators for "Speak Now" and "Door Open". Contact your sales representative for further details.

Reassurance tone setting is on page 19.

# **bellissimo 2-72 Way Video Entry System**

## **Multiple Entrances**

The *bellissimo* system allows multiple entrances to be catered for by the addition of a door controller and entrance panel for each entrance and additional power supplies.

## **Gate and Block Systems**

Sites with two or more blocks sharing one or more site entrances are catered for with our BSSW Gate controller. The blocks can then work independently but will receive calls from the shared entrance.

For further details see the “*bellissimo* and Bellcall Manual Gate and Block (PD-120)”.

## **Door Bell**

The BS Videophone has an input which can be used with a doorbell button (or other volt free contact) to ring the phone. This feature is intended to replace a separate doorbell. The ring is 2 seconds and all three indicators flash together.

## **Slave Output**

The BS Videophone has a slave output which can operate an external ringer or other device such as a flashing beacon.

This comprises of a volt-free contact which closes when the videophone is audibly ringing. The contact does not close when the videophone is muted.



# bellissimo 2-72 Way Video Entry System

## Design Considerations

### Equipment List

A BS-n bellissimo Video Kit (where n is the no of ways) comprises the following: -

Model No	Description
N x BS	Videophone (N is the no of phones)
1 x BSPn	Standard panel with a speech unit and camera.
1 x BSD8 or BSD72	Door controller (BSD72 required for > 8 ways)
M x BSC4	Video controller (one required for every 4 ways = N/4 rounded up)
K x PS4	4A 12V power supply. (one required for every 8 to 16 ways)
1 x 203	Fail-secure lock release

E.g. A BS6 Six way bellissimo Video Kit comprises the following: -

Model No	Description
6 x BS	Videophone
1 x BSP6	Standard SPA panel with a speech unit and camera
1 x BSD8	Door controller
2 x BSC4	Video controller
1 x PS4	4A 12V power supply
1 x 203	Fail-secure lock release

E.g. A BS22 Twenty two way bellissimo Video Kit comprises the following: -

Model No	Description
22 x BS	Videophone
1 x BSP22/VR	Vandal resistant panel with a speech unit and camera
1 x BSD72	Door controller
6 x BSC4	Video controller
2 x PS4	4A 12V power supply
1 x 203	Fail-secure lock release

For a bellini style kit order as BLV2 through BLV8. N.B. bellini systems do not include a 203 lock release.

### Options

The following options are available: -

- Extensions model **BS** videophone(s).
- Audio only phones model **BSA** as extensions.
- Additional entrances, each comprising a **BSD8** or **BSD72** controller and **BSPn** panel. (See also power supply requirements).
- Alternate lock releases, fail-safe and fail-secure.
- Timed Trades facility; specify **TRBS** to add another button and a **TS2000-BST** time-clock. On vandal resistant panels the extra button will be engraved "TRADES"
- Exit button. Model **5077** surface and model **5078** flush versions are available.
- Battery back-up power supply, **Model 840** (12V 4A).
- DDA panels (Contact sales for further information).
- Vandal Resistant Panels (standard above 8 ways)

# bellissimo 2-72 Way Video Entry System

## Entrance Panel – Important Note

Careful consideration should be given to the location of the entrance panel to ensure the best possible lighting conditions for the camera. In general strong back lighting of the subject (by the sun and sky) should be avoided, as the contrast between foreground and background may be too great for the camera. The field of view should contain as little of the sky as possible, particularly if south facing. If a backlit situation is unavoidable, additional lighting may be necessary to illuminate the caller and avoid a dark outline image (silhouette). A light coloured or reflective surface around the panel will redirect backlight to illuminate the caller.

## Door Controller

The door controller and power supply should be wall-mounted in a convenient cupboard or other protected environment with available mains power. Cable length to the entrance should be less than 50m. The door controller for the second and subsequent entrances may be situated in the same location, or to meet the 50m requirement may be situated in another location. Power supplies may be shared between door controllers placed in the same location, but controllers in separate locations must be separately powered.

## Video Controller

The video controller(s) and power supply(ies) should be wall-mounted in a convenient cupboard or other protected environment with available mains power. Cable length to the videophone should be less than 150m, see 'Cable Distances' page 13. In many cases the video controllers will be in the same location as the door controller(s), but they may be distributed as required to reduce wiring distances. When placed in different locations, each location must have its own local power supplies.

## Gate Controller

The gate switch controller BSSW is wired between the block door controllers and the video controllers, so would normally be wall mounted next to a door controller.

For further details see the “bellissimo and Bellcall Manual Gate and Block (PD-120)”.

## Separately Powered Videophones

The limitation of up to 4 videophones ringing but only one displaying, as indicated in the power supply and cable distance tables on page 13, can be overcome by the use of supplementary power from a 340C.

## Power Supply Requirements

The system is powered by 12V power supplies only: -

Model PS4 12V, 4A.

Model 840 12V, 4A battery backup supply.

Model 340C 12V, 1.5A optional for extensions.

Note 1. The 28V referred to on the videophone, video controller and wiring diagrams is internally generated in the controller. DO NOT use any power supply other than 12V or damage may occur.

Note 2. The PS4 power supply has been specifically designed to operate with the high-surge requirements of the system. Bell System is unable to guarantee functionality or provide support for systems which use third party power supplies.

# bellissimo 2-72 Way Video Entry System

Exact power supply requirements depend upon many factors. The number of power supplies included within a standard 'kit' or quotation assumes that all controllers are installed in one location and that there are no extensions.

The following table gives examples of the minimum number of controllers and power supplies for a given number of entrance doors and flats.

System	Control Equipment and Power Supplies
1 door 6 flats	1 x BSD8 door controller 2 x BSC4 video controller 1 x PS4 12V 4A power supply
2 door 6 flats	2 x BSD8 door controller 2 x BSC4 video controller 2 x PS4 12V 4A power supply
1 door 20 flats	1 x BSD72 door controller 5 x BSC4 video controller 2 x PS4 12V 4A power supply
2 door 20 flats	2 x BSD72 door controller 5 x BSC4 video controller 3 x PS4 12V 4A power supply

Distributed installations will typically require more power supplies. Also the use of other equipment such as coded access or proximity readers must be taken into account.

The following table is a guide to how much equipment a PS4 power supply can safely and reliably feed, please contact technical support for other variations.

Equipment 1 x PS4 can power	Comments
4 x BSC4 video controllers with 1 BS videophone per output.	16 videophones directly powered. Extensions may be added if separately powered by 340C's.
2 x BSC4 video controllers with up to 4 BS videophones per output.	Extension phones must be set to ring only, use the above configuration to allow the extensions to have a picture while ringing.
1 to 3 BSC4's with phones plus extensions	16 Videophones directly powered.
1 x BSD8/72 door controller and 3 x BSC4 video controllers with 1 BS videophone per output	12 videophones directly powered. Extensions may be added if separately powered by 340C's.
1 x BSD8/72 door controller and 1 x BSC4 video controllers with up to 4 BS videophones per output	Extension phones must be set to ring only, use the above configuration to allow the extensions to have a picture while ringing.
2 x BSD* door controllers (any type) with up to 2 cameras and 1A fail safe locks.	Both door controllers must be in the same location. No spare current available for other equipment unless both cameras or all the lock current is not used.

# bellissimo 2-72 Way Video Entry System

## Cable Specification

All system wiring must be carried out using **Cat5** signal cable and where necessary 1mm<sup>2</sup> (or greater) power cable as tabulated below. Cat5 cable has a known performance for the transmission of video signals, whilst telephone or alarm cables are not suitable.

**Bell System will be unable to offer any warranty or support for systems installed using incorrect cables.**

## Cat5 Cable Specification

Cat5 is our short reference for EIA standard UTP Category 5 Unshielded Twisted Pair data cable. This is a standard solid core twisted pair cable having 4 pairs (8-cores) and no shield. The cores are in pairs where Blue and 'Blue with a White stripe' are twisted together as the first pair. The other three pairs are similar with main colours Orange, Green and Brown.

- Also available and acceptable are:

UTP Category 5e (Cat5e)

UTP Category 6 (CAT6)

UTP Category 6e (CAT6e)

The exact cable can be chosen from the above on cost and availability grounds.

- STP (Shielded Twisted Pair) cables are **not** recommended.
- UTP "patch cables" are **not** recommended.

NOTE: Cat5 cable is easily identifiable as the specification is printed on the sheath

Patch cable is used for the desk phone to wall connection as this requires a flexible cable. The reason for not using it for general wiring is that attenuation is higher and video distances would be reduced by at least ½, it also costs 2 to 3 times as much as standard Cat5.

Spurs. A daisy chain run with one or more spurs of up to 3 metres is allowed. For example a desk phone connection.

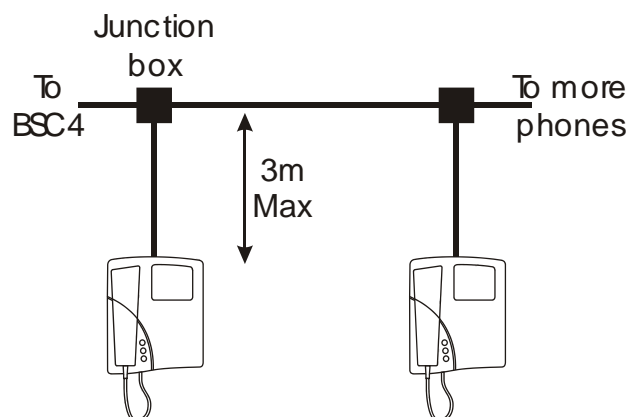

# bellissimo 2-72 Way Video Entry System

## Cable Distances – Colour Videophones

Video Controller to Videophone			
System	Distance	Cable	Comments
Single videophone per output	< 150m	1 x Cat5	
	> 300m	1 x Cat5 2 x 1mm <sup>2</sup>	
Single videophone + 3 extensions on each output, all cable powered	< 50m	1 x Cat5	Only Master videophone has 'Auto display'; extensions are daisy-chained
	< 200m	1 x Cat5 2 x 1mm <sup>2</sup>	
Single videophone per output with separately powered extensions	< 150m	1 x Cat5	150m maximum to the cable powered videophone; daisy-chain up to 300m total.
	> 300m	1 x Cat5 2 x 1mm <sup>2</sup>	
All videophones locally powered with a 340C power supply	< 300m	1 x Cat5	Locally powered videophones have 'Auto display'; extensions are daisy-chained
	<25m to 340C	1 x pair of Cat5	
	<100m to 340C	2 x 1mm <sup>2</sup>	

Door Controller to Video Controller(s)			
System	Distance	Cable	Comments
All Systems	<200m	1 x Cat5	N.B. maximum length from any camera to any videophone to be less than 300m

Panel to Door Controller			
System	Distance	Cable	Comments
All Systems, each entrance	<50m	1 $\frac{1}{8}$ x Cat5 + $\frac{1}{8}$ per button	See page 28 for detail
Lock Release up to 1A	<10m	$\frac{1}{4}$ x Cat5	
	<50m	2 x 1mm <sup>2</sup>	
Option: Exit button	<50m	$\frac{1}{4}$ x Cat5	
Option: Trades button	<50m	$\frac{1}{4}$ x Cat5	Requires a Time-clock
Option: Door Monitor Switch	<50m	$\frac{1}{4}$ x Cat5	

Power Supply to Controller			
System	Distance	Cable	Comments
All Systems, each PS4 to BSD8 or BSD72 or BSC4	<3m	2 x 1mm <sup>2</sup>	Total length of any daisy chain
	<5m	2 x 1.5mm <sup>2</sup>	

NB. A Cat5 cable has 4-pairs (8 cores)

For larger cable distances please contact manufacturer.

# bellissimo 2-72 Way Video Entry System

## Installation & Commissioning

### Checklist

The following checklist is a summary of what is required. Refer to the relevant pages for further details.

- Review the section headed 'Safety Information' on page 42.
- Ensure that 'Design Considerations' on page 9 have been understood.
- Confirm that Cat5 cable has been specified.
- Install the system according to instructions in this section.
- Check/set the door controller jumper and switch settings.
- Check/set the video controller jumper and switch settings.
- Check/set each videophone dipswitch settings.

### Wiring

Refer to the diagrams from page 28 onwards as appropriate for the equipment you have.

All wiring is carried out using a mixture of Cat5 for the signal wiring and 1mm<sup>2</sup> (or greater) cores for the power wiring; refer to Page 12 for further details. It is strongly recommended that a consistent colour code be used throughout such as that indicated on the connection diagram. Certain signals must be interconnected using a twisted pair from the Cat5 cable. These are clearly marked on the connection diagram and should be strictly observed.

### Entrance Panel

The panel should be mounted at an optimum height of 1.6 m, measured between the ground and the centre of the camera window. With flush mounting panels it is advisable to apply mastic to the top and side edges of the panel to prevent water ingress behind the panel, but not to the bottom edge. On construction sites the panel must be protected from corrosive substances such as 'brick acid'. The panel should be cleaned only with a damp cloth containing dilute detergent.

### Videophone

The videophone is designed to be wall mounted onto plasterboard or other masonry at an optimum height of 1.6m. It should be fixed with three No 8 pan head screws (not supplied). Use the dimensions shown on the adjacent diagram. If the cable is to be fed from the wall cavity then make a hole for this at the same time, the surface cable exit is to the left of the cut-out. The top two screws are hidden fixings, so screw in but do not fully tighten. Test hang the videophone and adjust the screws as required.

Now remove the top cover of the videophone, which is secured by a clip at the bottom. Hang the videophone on the two screws already fitted allowing the cable (if present) to feed through and the third screw to be inserted at the bottom. Tighten the third screw.

If the silicone rubber buttons fall out, clip them back into the PCB. Before replacing the Front Cover remove the protective film from the display lens and also check that the DipSwitch settings are correct or change as necessary (see Page 22).

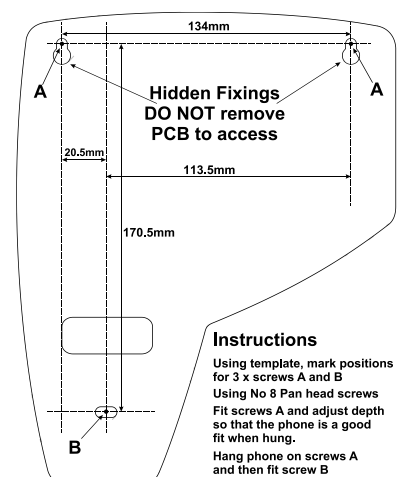

# bellissimo 2-72 Way Video Entry System

## Audio Phones

The BSA audio phone can be used as a lower cost alternative to an extension videophone. It is styled like the bellissimo videophone. The phone is manufactured in white and grey high-impact ABS plastic that imparts high durability and compliments most wall furnishings. It incorporates both **mute** and **lock** illuminated buttons and it has an Electronic Ringing Tone with rotary preset volume.

## BSA Phone

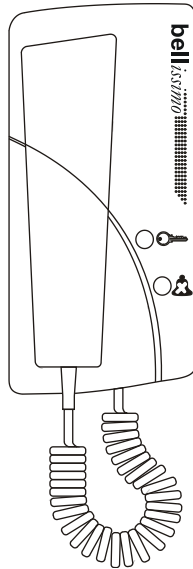

## Electric Door Release

Both fail-secure and fail-safe lock releases (including magnetic locks) use the same terminals. To set the lock type, refer to the 'Door Controller Settings'. When installing lock releases please allow a little movement on the door, as operation will be impaired if fitted too tight.

NB. Magnetic locks (maglocks) must be fitted with a suppressor at the lock terminals. Some manufacturers fit an acceptable internal suppressor.

## Fail Safe Exit: Notes

Fail safe exits require an exit button and this should be normally open so that the controller can be used to give a timed exit. If the exit button has both normally open and normally closed contacts, then the normally closed contact can be wired in series with the release or maglock along with the break glass in case of equipment failure.

A not uncommon problem with maglocks, because they cannot be mechanically overridden, is being locked out of the building due to lost codes, fobs or equipment failure. So consider an alternate building entrance, or an externally accessible secure keyswitch, or a reliable method of disabling the system during overnight secure lockup.

# **bellissimo 2-72 Way Video Entry System**

## **Fail Secure Exit: Notes**

Commonly fail secure exit doors incorporate a thumb-turn, door handle or mini push bar rather than use of an exit button. Fire officers usually require a minimum of door handle or push bar to open a door on a fire exit route – not a thumb-turn.

Most fail secure locks are not continuously rated and if an electrical hold open system is used for say busy times, then a continuously rated release must be used.

Powered bolt, shoot-bolt or other more secure door locking systems may require the use of separate power supplies or a suppressor to be fitted. Shoot-bolt systems for instance tend to require at least 1.5A peak current and this will require the use of an isolation relay and a separate power supply for the lock.

## **Exit Button Input**

The exit button is used to unlock the door for the preset lock operating time. The input is designed only for use with a normally open push button. 'Exit +' is the input and 'Exit -' is internally connected to 0V.

The 'Exit +' input can also be used for connection to other equipment to open the door as shown in Diagram K – *bellissimo* Combined System Connections.

## **Door Open Switch**

The door open switch is used to provide an indication at the phone that the door has been left open. This switch can have closed contacts when the door is closed or open contacts when the door is closed, the choice being made in Panel Programming. The default of 'contacts open when door closed' must be selected when this feature is not required.

## **Time Clock Sharing**

In a large system a single time clock can be shared between distributed equipment areas by borrowing one of the 'comm -' wires in the interconnecting Cat5 to use as the shared "Time clock common". See the detailed diagram on page 36.

## **Commissioning**

The major components of the **bellissimo** Video system are fitted with high quality pluggable screw terminal blocks. This enables all the connections to the system to be fully completed, whilst easily isolating individual pieces of equipment during testing and commissioning.

When powering up for the first time, it is highly recommended that only the most basic system be connected. i.e. 1 BS videophone, 1 door controller and panel, and 1 video controller; the remaining equipment can be isolated by unplugging terminal blocks.

NB: Ensure the 1 door and video controller remain interconnected and that the 'end of line' controller is terminated temporarily using the jumpers (see page 20).

Proceed to test the system by calling the videophone from the door panel in the usual way. Any problems can be resolved by rechecking wiring and connections, assisted by the various suggestions and tests in the section "Troubleshooting". Once the basic system is fully functioning, continue to reconnect and test the remaining equipment item by item until completed.



# bellissimo 2-72 Way Video Entry System

## BSD8/72 Door Controller Switch Settings

### Talking Time/Videophone Active DIP SW1 (1-4)

4	3	2	1	Talk Time
On	On	On	On	15s
On	On	On	Off	20s
On	On	Off	On	30s
On	On	Off	Off	45s
On	Off	On	On	60s
On	Off	On	Off	75s
On	Off	Off	On	90s
On	Off	Off	Off	120s
Off	On	On	On	150s
Off	On	On	Off	180s
Other settings				60s
<b>Off</b>	<b>Off</b>	<b>Off</b>	<b>Off</b>	<b>60s*</b>

\*Default setting

SW1 SW2 SW3

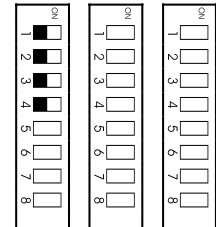

OFF ↔ ON

### Ringing Time/Call Time and Ring Effect DIP SW1 (5-8)

8	7	6	5	Call Time	Ring Cadence or Sound Effect
On	On	On	On	5s	1 in 3 – 1 ring every 3 seconds
On	On	On	Off	8s	1 in 3 – 1 ring every 3 seconds
On	On	Off	On	10s	1 in 3 – 1 ring every 3 seconds
On	On	Off	Off	15s	1 in 3 – 1 ring every 3 seconds
On	Off	On	On	20s	1 in 3 – 1 ring every 3 seconds
On	Off	On	Off	30s	1 in 3 – 1 ring every 3 seconds
On	Off	Off	On	40s	1 in 3 – 1 ring every 3 seconds
On	Off	Off	Off	45s	1 in 3 – 1 ring every 3 seconds
Off	On	On	On	50s	1 in 3 – 1 ring every 3 seconds
Off	On	On	Off	60s	1 in 3 – 1 ring every 3 seconds
Off	On	Off	On	30s	1 in 3 (Reserved For future use)
Off	On	Off	Off	30s	1 in 3 (Reserved For future use)
Off	Off	On	On	30s	2 in 15 – 2 rings, 15S silence, repeat
Off	Off	On	Off	30s	1 in 15 – 1 ring, 15S silence, repeat
Off	Off	Off	On	30s	1 in 5 – 1 ring every 5 seconds
<b>Off</b>	<b>Off</b>	<b>Off</b>	<b>Off</b>	<b>30s*</b>	<b>1 in 3* – 1 ring every 3 seconds</b>

\*Default setting

SW1 SW2 SW3

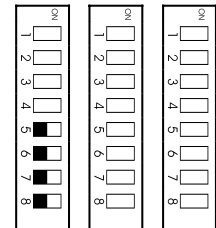

OFF ↔ ON

# bellissimo 2-72 Way Video Entry System

## Lock Operate Time Dip SW2 (1-3)

3	2	1	Lock Time
On	On	On	3s*
On	On	Off	4s
On	Off	On	5s
On	Off	Off	6s
Off	On	On	8s
Off	On	Off	10s
Off	Off	On	15s
Off	Off	Off	20s

\*Default setting

## SW1 SW2 SW3

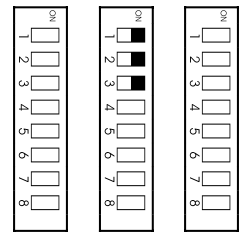

OFF ↔ ON

## Individual Functions DIP SW2 (4-8)

## SW1 SW2 SW3

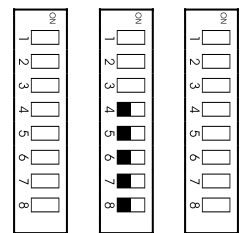

OFF ↔ ON

<b>SW2-4</b>	<b>Lock Type</b>	<b>Lock behaviour during power failure</b>
*Off	Fail secure lock	Requires alternate mechanical means, key or thumb-turn to open on power failure
On	Fail safe lock	Lock opens on power failure
<b>SW2-5</b>	<b>Door Status Switch</b>	<b>Monitors doors left open</b>
*Off	Contacts Open when Door is Closed	The default allows for no switch fitted
On	Contacts Closed when Door is Closed	Standard normally closed switch
<b>SW2-6</b>	<b>Camera 2</b>	<b>How many cameras at this door</b>
*Off	Camera 1 only	Default – single camera per door
On	Enable Camera 2	Second camera at the door
<b>SW2-7</b>	<b>View Function</b>	<b>Camera action when view button pressed</b>
*Off	Local View	View button only selects the camera(s) at this door
On	Global View (See DIP SW3 below)	View button sequentially selects all cameras at doors with this switch set
<b>SW2-8</b>	<b>Reserved</b>	
*Off		
On		

\*Default setting

# bellissimo 2-72 Way Video Entry System

## Camera Numbering DIP SW3 (1-8)

Camera 1 at this door				
4	3	2	1	Number
On	On	On	On	*1
On	On	On	Off	2
On	On	Off	On	3
On	On	Off	Off	4
On	Off	On	On	5
On	Off	On	Off	6
On	Off	Off	On	7
On	Off	Off	Off	8
Off	On	On	On	9
Off	On	On	Off	10
Off	On	Off	On	11
Off	On	Off	Off	12
Off	Off	On	On	13
Off	Off	On	Off	14
Off	Off	Off	On	15
Off	Off	Off	Off	16

Last Camera				
8	7	6	5	Number
On	On	On	On	*1
On	On	On	Off	2
On	On	Off	On	3
On	On	Off	Off	4
On	Off	On	On	5
On	Off	On	Off	6
On	Off	Off	On	7
On	Off	Off	Off	8
Off	On	On	On	9
Off	On	On	Off	10
Off	On	Off	On	11
Off	On	Off	Off	12
Off	Off	On	On	13
Off	Off	On	Off	14
Off	Off	Off	On	15
Off	Off	Off	Off	16

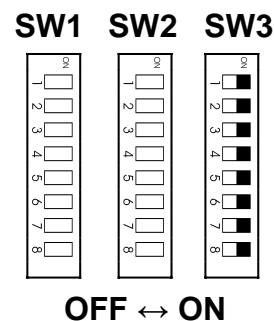

\*Default setting

### View Activated by User (CCTV mode)

User activation on 2-72 way system is not available.

### 'Global View' at Multiple Entrances

For information on this feature consult Bell System (Telephones) Ltd. technical department at the number shown on the last page.

## BSD8/72 Door Controller Jumper Settings

### Camera Terminator

There is a separate jumper for both video Camera inputs. This has three settings, 75R for terminating coaxial cable, 100R for terminating twisted pair Cat5 cable and None for use when passing the cable on to another device or controller.

### Video Gain Control

The "Video Gain" jumper on door controllers should always be set to "0" unless directed by 'Bell System Technical Support'. This jumper is only required on some systems with very long camera to videophone cable runs well in excess of 150m. Inappropriate use of this jumper with short runs will cause picture problems.

### Reassurance tones

DDA reassurance tones are activated by placing a jumper between pins 1 & 2 of the "Prog" 5 pin header on the BSD8/72 controller PCB (see diagram on page 30), the jumper is stored between pins 4 & 5. Once activated the speaker in the door panel will ring with the videophone and buzz when the lock is opened from the videophone.

# bellissimo 2-72 Way Video Entry System

## BSC4 Video Controller Settings

### Jumper settings

The “Video Gain” jumper on video controllers should always be set to “0” unless directed by Bell System Technical. This jumper is only required on some systems with very long camera to videophone cable runs well in excess of 150m. Inappropriate use of this jumper with short runs will cause picture problems.

The “Video Terminator” jumper must be set to OFF on all but the furthest Video Controller from the Door Controller(s), this one must be set to ON.

### Switch settings

SW6 is a rotary 16 position switch which sets the videophone addresses as per the following table. These numbers represent actual flat numbers for the digital controllers, they also correspond to the inputs on the BSD8 or BSD72.

SW6 Setting				
Pos	Phone 1	Phone 2	Phone 3	Phone 4
0	None	None	None	None
1	1	2	3	4
2	5	6	7	8
3	9	10	11	12
4	13	14	15	16
5	17	18	19	20
6	21	22	23	24
7	25	26	27	28
8	29	30	31	32
9	33	34	35	36
A	37	38	39	40
B	41	42	43	44
C	45	46	47	48
D	49	50	51	52
E	53	54	55	56
F	57	58	59	60

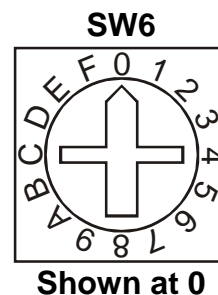

#### ATTENTION

Each SW6 MUST be set correctly for the phones to ring.

This switch is shipped set to 0 to prevent multiple phones ringing on initial installation.

### Address Offset SW7 – Builds up to 6C

SW7 is a 4 bit switch that is used to increase the addressing range. For each bit that is switched ON add the corresponding value to the address set by SW6. This allows phone 1 flat addresses up to 240 to be set.

Bit	Offset
1	+60
2	+120
3	+1
4	+2

Each bit on SW7 adds the corresponding amount to the address set by SW6.

#### SW7



OFF ↔ ON

### Extended Addressing Jumper PROG pins 2-3 – Build 6C

This jumper adds +240 to the phone 1 address set using SW6 and SW7. Custom versions will show the custom offset on the build label. The jumper is stored on pins 4-5.

# bellissimo 2-72 Way Video Entry System

## Address Offset SW7 – Build 7 onwards

SW7 is an 8 bit switch that is used to increase the addressing range. For each bit that is switched ON add the corresponding value to the amount set by SW6. This allows flat addresses up to 3210 to be set (6410 or higher with the jumper below).

Bit	Offset
1	+1
2	+2
3	+50
4	+100
5	+200
6	+400
7	+800
8	+1600

Each bit on SW7 adds the corresponding amount to the address set by SW6. Do not set a total value above 9995

SW7

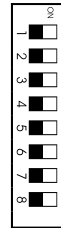

OFF ↔ ON

## Extended Addressing Jumper PROG pins 2-3 – Build 7

This jumper adds +3200 to the phone 1 address set using SW6 and SW7. Phone addresses up to 6410 (Phone 1 output) can be set. Custom versions will show the custom offset on the build label.

The use of this jumper precludes the use of Odd/Even addressing by PROG pins 1-2, if both are required contact Bell System Technical. The jumper is stored on pins 4-5.

## Custom Alternate Addressing

Special versions of the BSC4 can be ordered to allow addressing above 6413. For instance by making the jumper add 5000 the BSC4 would be able to address from 1 to 3210 and 5001 to 8210 (Phone 1 output).

## Extended Addressing Jumper PROG pins 2-3 – Build 7A

This jumper adds +nn00 to the phone 1 address set using SW6 and SW7. The value +nn00 is shown on the build label. The jumper is stored on pins 4-5.

The use of this jumper precludes the use of Odd/Even addressing by PROG pins 1-2, if both are required contact Bell System Technical. The jumper is stored on pins 4-5.

## Odd/Even Addressing Jumper PROG pins 1-2 – Builds 5C, 6C and 7 onwards

This jumper alters the addressing of Phone outputs 2, 3 and 4 such that they all become either odd or even numbers. So if the address of phone 1 is 12 say the other outputs become 14, 16 and 18. If the address were 31 then the other outputs are 33, 35 and 37.

The use of this jumper precludes the use of extended addressing by PROG pins 2-3, if both are required contact Bell System Technical. The jumper is stored on pins 4-5.

# bellissimo 2-72 Way Video Entry System

## BS Videophone Switch Settings

### Mute Time Settings (1-4)

4	3	2	1	Mute Time
On	On	On	On	Disabled <sup>1</sup>
On	On	On	Off	2 minutes
On	On	Off	On	5 minutes
On	On	Off	Off	10 minutes
On	Off	On	On	15 minutes
On	Off	On	Off	20 minutes
On	Off	Off	On	30 minutes
On	Off	Off	Off	45 minutes
Off	On	On	On	1 hour
Off	On	On	Off	2 hours
Off	On	Off	On	4 hours
Off	On	Off	Off	5 hours
Off	Off	On	On	6 hours
Off	Off	On	Off	8 hours
Off	Off	Off	On	10 hours
<b>Off</b>	<b>Off</b>	<b>Off</b>	<b>Off</b>	<b>*Indefinite<sup>2</sup></b>

### Settings

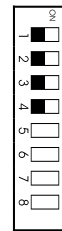

OFF ↔ ON

<sup>1</sup>Default setting<sup>1</sup>Disabled means touching the **mute** symbol has no effect.

<sup>2</sup>Indefinite; the **mute** is cancelled by touching the symbol again.

### Individual Functions Settings (5-8)

### Settings



OFF ↔ ON

SW-5	Master / Extension	Which Videophone to set
*Off	Master	Only or first apartment station per BSC4 output.
On	Extension / Slave	Second and subsequent videophones per BSC4 output.
SW-6	Auto Display on Ring	Videophone display behaviour
*Off	Display during ring	Picture is on while ringing, stays on when answered.
On	No display during ring	Picture is off while ringing, comes on when answered.
SW-7	Spare	Spare
*Off		
On		
SW-8	Spare	Spare
*Off		
On		

\*Default setting

### Video Terminator Jumper Setting

The jumper is situated above the input connector. It is 3 pin and labelled On and Off.

The jumper should be on when there is only one videophone on an individual BSC4 output. Otherwise only the last videophone should have a jumper set to On the rest being set to Off.

# bellissimo 2-72 Way Video Entry System

## Troubleshooting

### Common Faults

A very high percentage of calls to our technical support number, regarding new installations, are resolved to faulty wiring. The reasons for these are various: -

Broken cores, especially short links, sometimes broken inside the insulation!

Connectors clamped onto the insulation instead of copper.

Wire in the wrong side of a rising clamp connection, the clamps need to be unscrewed far enough to stop the wire going "underneath".

Shorts or opens due to cables having been stapled or nailed through.

A common fault is wiring a connector left to right instead of right to left, or one or more twisted pairs the wrong way round.

**Tip.** The heads of screws on connectors are not a reliable means of making a connection with a meter, try pushing the probe into the wire entry point.

### Quick Fault Reference

These tables provide a quick indication of the possible fault.

Power Problems	
Videophone resetting (The three indicators lights show the power on sequence).	<ul style="list-style-type: none"><li>• Power supply intermittent short or overload.</li><li>• More than 1 extension enabled for auto display.</li><li>• Lock output short-circuit; see 'Lock Problems'</li></ul>
28V LED does not light on controller.	<ul style="list-style-type: none"><li>• Temporarily remove connection to 28V+ output. If it now comes on there is a short on the phone cabling.</li><li>• 12V input connections are reversed or missing.</li></ul>
PS4 output voltage fluctuating, meter reading unstable.	<ul style="list-style-type: none"><li>• Output overload is causing current limit to operate, check grouping of controllers to power supplies, see page 10 for details</li><li>• See Lock Problems below</li></ul>

Call Problems	
Videophone does not ring or flash when called	<ul style="list-style-type: none"><li>• Videophone off hook or muted.</li><li>• No power to videophone; check that the red mute lamp flashes when the handset is picked up.</li><li>• Data wiring has a fault, Data A or B broken.</li><li>• 0V to controller missing on separately powered videophone.</li><li>• Pushbutton wiring error, try short length at controller.</li></ul>
No extension videophone rings or flashes when called	<ul style="list-style-type: none"><li>• Master videophone off hook or muted.</li></ul>
Green Lock light on videophone flashes once when called	<ul style="list-style-type: none"><li>• Videophone set to extension with no master present or responding.</li></ul>

# bellissimo 2-72 Way Video Entry System

## BSC4 Video Controller Tests

When the system is idle (no calls in progress) pressing the 'Test' button activates the 'Audio On', 'Status' and one of the 'Select n' LED's for 3S. If the system is not idle (Version 2 only) pressing the 'Test' button will cause a system wide reset.

There are 4 green LED's which indicate power to the individual phones, on board fuses will operate if a short exists.

The BSC4 also has 4 'phone' test buttons which can be used to verify the 'data' connection to the videophone. Pressing the 'Test phone n' button should cause the videophone and extensions, if any, to ring and the associated 'Select n' Led to light.

Picking up the handset or pressing **view** will cause the 'Audio On' and 'Select n' LED's to light. There will be no audio as no door panel is active. The display on the videophone will light up to grey or blue unless the video camera is directly wired to the BSC4 input.

Replacing the handset will cause all the LED's to extinguish. Pressing the lock button instead of replacing the handset will cause the 'Status' LED to light and after 3S all the LED's will go off.

If this sequence works repeatedly then the A and B data connections are probably OK. and the +28V and 0V must also be OK. The test also shows that the BSC4 software is running and diagnostics can now focus on the door controller to video controller wiring.

If it fails a videophone can be connected locally with a short cable to eliminate the cable being faulty.

Lock Release Problems	
Lock release does not operate or clicks but does not open.	<ul style="list-style-type: none"><li>• Connections to Lock Release are open or shorted.</li><li>• Voltage drop due to cable too thin.</li><li>• Lock current is too high; Power supply is resetting.</li><li>• Lock release jammed due to over tight fitting.</li></ul>
Maglock does not hold strongly.	<ul style="list-style-type: none"><li>• Voltage drop due to cable too thin.</li></ul>
<b>TEST:</b> Press 'Test' Button on Door Controller (when system idle):	<ul style="list-style-type: none"><li>• Confirm 'LOCK' LED illuminates for 3 seconds.</li><li>• Check Output Voltage at LOCK terminals.</li></ul>
Lock release operates all the time or in reverse.	<ul style="list-style-type: none"><li>• Check fail safe/fail secure SW2-4 selection matches the lock type.</li><li>• Normally closed switch has been used for exit button.</li></ul>
Lock operates from the exit button but not the test button or phone.	<ul style="list-style-type: none"><li>• Normally closed switch has been used for exit button.</li></ul>



# bellissimo 2-72 Way Video Entry System

Video Problems	
Blank picture when: - Calling videophone or Pressing <b>view</b>	<ul style="list-style-type: none"> <li>• Broken or missing Video + or Video – wire.</li> <li>• Cameras incorrectly configured refer to SW2-6 settings on page 18</li> <li>• Call is from an audio only panel.</li> </ul>
No picture when calling videophone	<ul style="list-style-type: none"> <li>• Check auto display switch is on. See page 22</li> </ul>
No picture when pressing <b>view</b>	<ul style="list-style-type: none"> <li>• CCTV not available on Multiway systems.</li> </ul>
Pressing <b>view</b> locks up system	<ul style="list-style-type: none"> <li>• Ensure SW2-8 is OFF, see page 18</li> </ul>
Repeated pressing of view does not select cameras in sequence as expected.	<ul style="list-style-type: none"> <li>• Check SW2-6 at all entrances is set for correct number of cameras at that entrance</li> <li>• Check settings for SW3 if SW2-7 is enabled</li> <li>• See section 'Global View' on page 19</li> </ul>
Unstable picture	<ul style="list-style-type: none"> <li>• Power supply voltage low.</li> <li>• Terminator switch not set on last videophone.</li> <li>• Too many terminator switches set on.</li> <li>• Video gain jumper set to high on a short run.</li> <li>• Very bright area in background upsetting camera.</li> </ul>
Unstable picture possibly with areas looking like a photographic negative.	<ul style="list-style-type: none"> <li>• Video + and – reversed, or M and S reversed.</li> </ul>
Entrance cannot be seen at night	<ul style="list-style-type: none"> <li>• Power not connected to camera IR night illumination. Connect 1 to + on camera.</li> </ul>

Speech Problems	
Loud tone at the entrance speaker. (Acoustic feedback)	<ul style="list-style-type: none"> <li>• Volume controls set too high</li> <li>• Broken Audio 1 or 2 wire in the cabling.</li> <li>• Intermittent or broken wire in Data A or B.</li> <li>• Videophone has reset; see the power faults table.</li> <li>• Check model 61 is hard against the panel with no gaps.</li> <li>• Check model 61 speech unit is the right way round and that the microphone hole in the speech unit lines up with the hole in the panel.</li> </ul>
Low volume speech in one or both directions	<ul style="list-style-type: none"> <li>• Adjust pot on 61 speech unit marked A and with a speaker symbol for volume at the panel.</li> <li>• Adjust pot on 61 speech unit marked B and with a microphone symbol for volume at the phone.</li> <li>• If volume cannot be increased in one direction without feedback, the volume in the other direction may have to be reduced as a compromise.</li> <li>• Check model 61 is hard against the panel with no gaps.</li> <li>• Check model 61 speech unit is the right way round and that the microphone hole in the speech unit lines up with the hole in the panel.</li> </ul>
No speech from videophone to entrance	<ul style="list-style-type: none"> <li>• Missing R core to door controller</li> <li>• Broken Audio 1 or 2 connections.</li> </ul>
No speech from entrance to videophone	<ul style="list-style-type: none"> <li>• Missing T core to door controller</li> <li>• Broken Audio 1 or 2 connections.</li> </ul>

# bellissimo 2-72 Way Video Entry System

## Specifications

<b>BSD8/72 Door controller</b>	
Size	BSD8: 185mm x 230mm x 42mm BSD72: 360mm x 240mm x 40mm
Supply Voltage	10.8V min, 13.8V typical, 15V max
Current Consumption	80mA idle @13.8V, 250mA active includes speech not cameras

<b>Model CAMBS-C Colour Camera</b>	
Size	60mm x 57mm x 31mm
Supply Voltage	10V d.c. minimum, 15V d.c. maximum
Current consumption	175mA maximum without IR 215mA maximum with IR (Link 1 to +)
Image Device	1/3" CCD
Sensitivity	0.01 lux, auto switching to B/W in low light levels
Minimum Focus	100mm
Viewing Angle	92° (typical)
Video Output	PAL composite video 1Vpk-pk (75 Ohm)
Resolution	More than 330 lines
Back light compensation	Yes

<b>BSC4 Video Controller</b>	
Size	185mm x 230mm x 42mm
Supply Voltage	10.8V min, 13.8V typical, 15V max
Current Consumption	350mA idle, 3A max @13.8V

<b>BS Colour Videophone</b>	
Size	180mm x 225mm x 60mm
Fixing	Wall Mounted
Supply Voltage	11V minimum – local power supply only. 20V to 28V typical
Current Consumption	25mA @28V idle, 375mA @ 11V active
Buzzer Mute Time	Disabled, 1minute through 10 hours, indefinite

<b>Model BSA Phone</b>	
Size	105mm x 235mm x 25mm
Supply Voltage	10V d.c. minimum, 30V d.c. maximum
Current consumption	20mA idle, 67mA ringing @13.8V

<b>Model 61 Speech Unit</b>	
Size	98mm x 60mm x 24mm
Supply Voltage	10V d.c. minimum, 15V d.c. maximum
Current consumption	100mA d.c. maximum

# bellissimo 2-72 Way Video Entry System

<b>PS4 Power Supply</b>	
Size	236mm x 105mm x 81mm
Output Voltage (regulated)	13.5V d.c. min, 13.8V d.c. nom, 14.1V d.c. max
Output Current	3A continuous, 4A peak (5 minutes max)
Mains Supply Internal Fuse	Not user replaceable
Supply Voltage	230V 50Hz nominal
Temperature Range	0 °C to 50 °C

<b>340C Power Supply</b>	
Size	140mm x 60mm x 53mm
Output Voltage (regulated)	13.5V Min, 13.8V Nom, 14.1V Max
Output Current	1A continuous, 1.5A peak (5 minutes max)
Mains Supply Internal Fuse	Not user replaceable
Supply Voltage	230V 50Hz nominal
Temperature Range	0 °C to 50 °C

<b>840 Power Supply – Battery Backed</b>	
Size	350mm x 330mm x 80mm
Output Voltage (regulated)	13.5V Min, 13.8V Nom, 14.1V Max
Output Current	3A continuous, 4A peak (5 minutes max)
Mains Supply Internal Fuse	T2A 20mm HBC (HRC) Ceramic
Battery Fuse	F4A 20mm Glass
Supply Voltage	230V 50Hz nominal
Temperature Range	0 °C to 50 °C

<b>BSSW Gate Switcher / Block Isolator</b>	
Size	185mm x 230mm x 42mm
Supply Voltage	10.8V min, 13.8V typical, 15V max
Current Consumption	80mA idle, 210mA max @13.8V

# bellissimo 2-72 Way Video Entry System

## Diagram A – 2-72 Way Basic System Overview Cabling

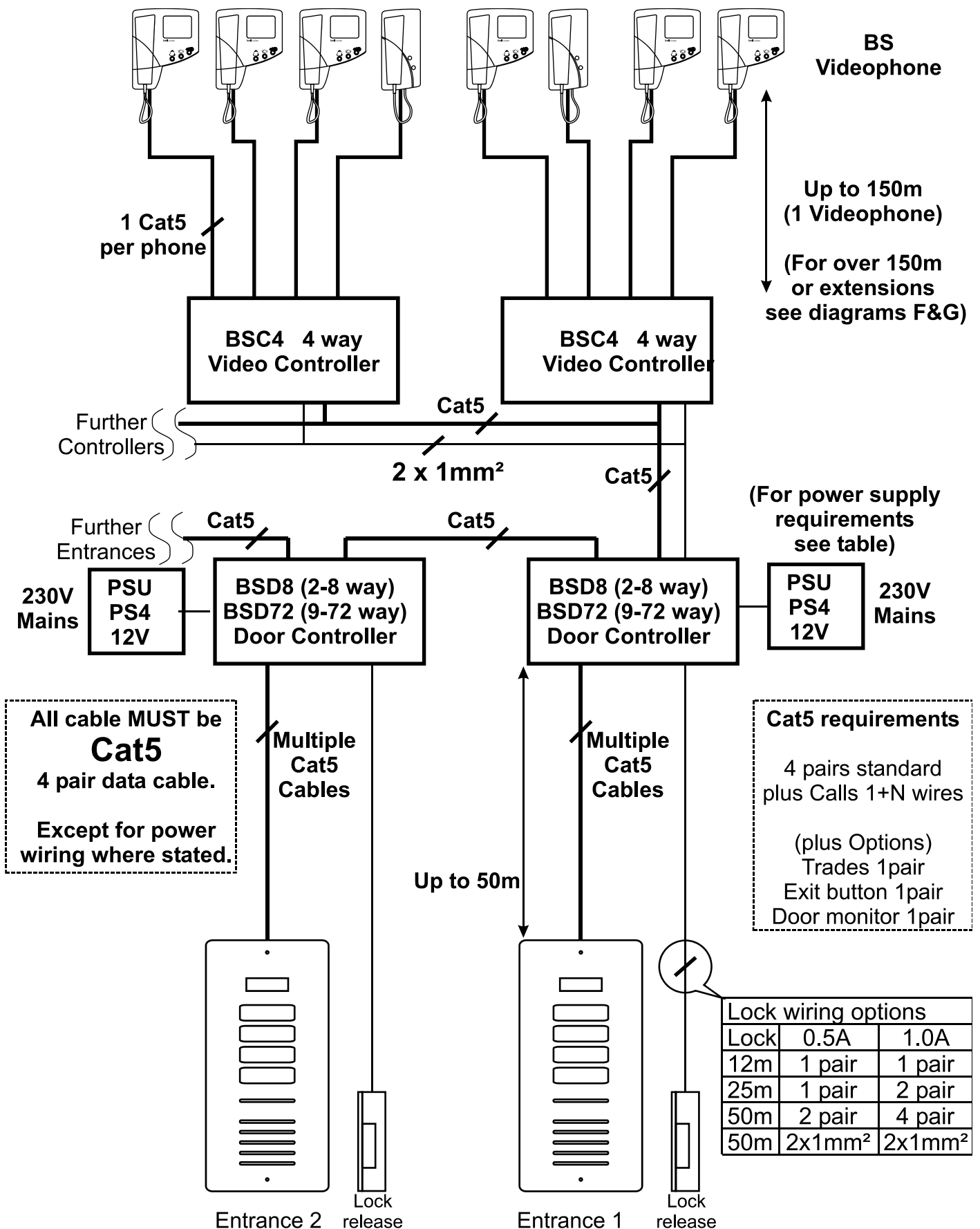

# bellissimo 2-72 Way Video Entry System

Diagram B – Large system Overview  
Illustration of Power Supply Distribution

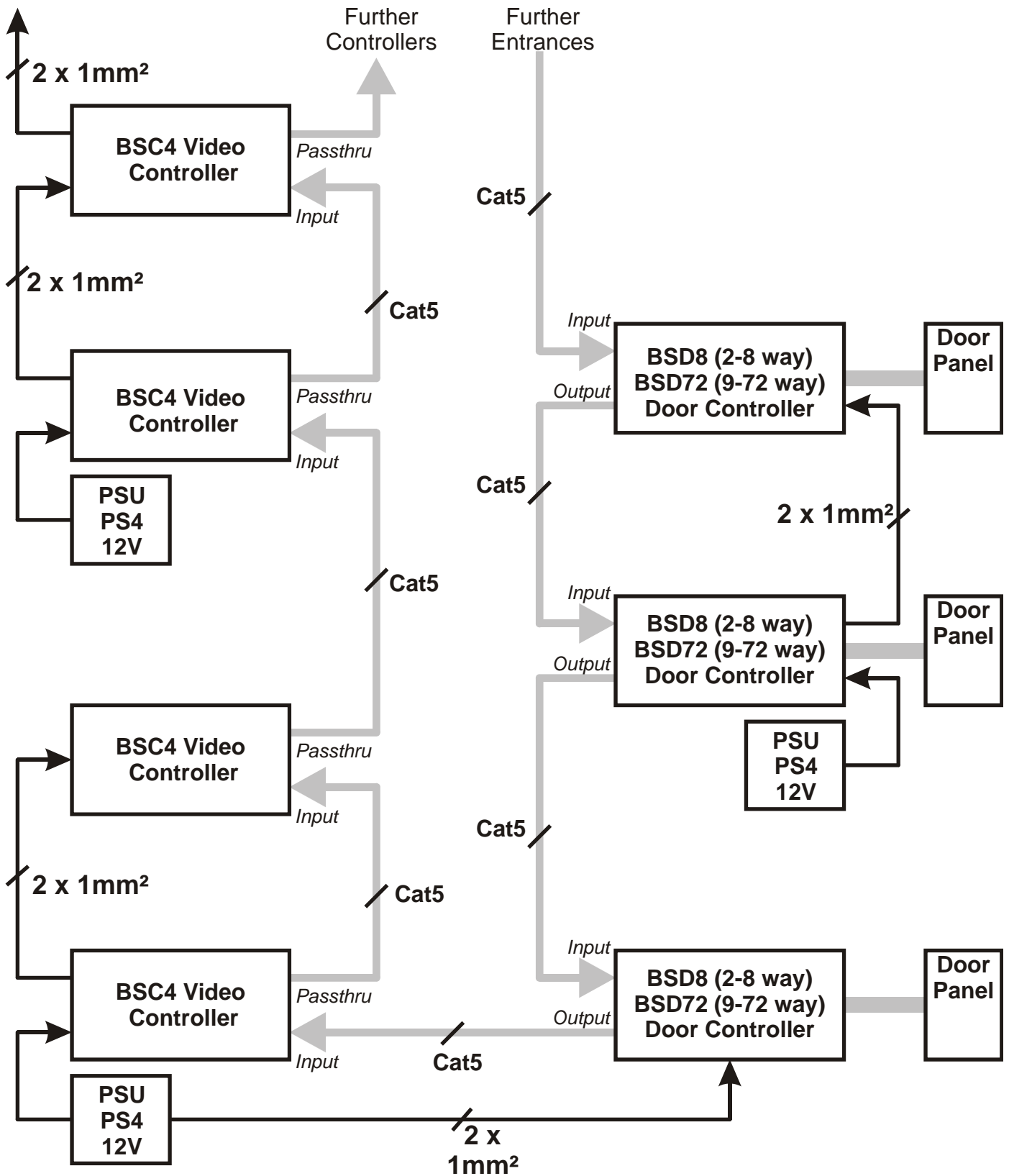

# bellissimo 2-72 Way Video Entry System

## Diagram C – BSD8 PCB Detail

The 72 way Expansion PCB not shown It simply has 8 by 8 way terminal blocks For Call Inputs 9 to 72 and is connected by a short ribbon connector

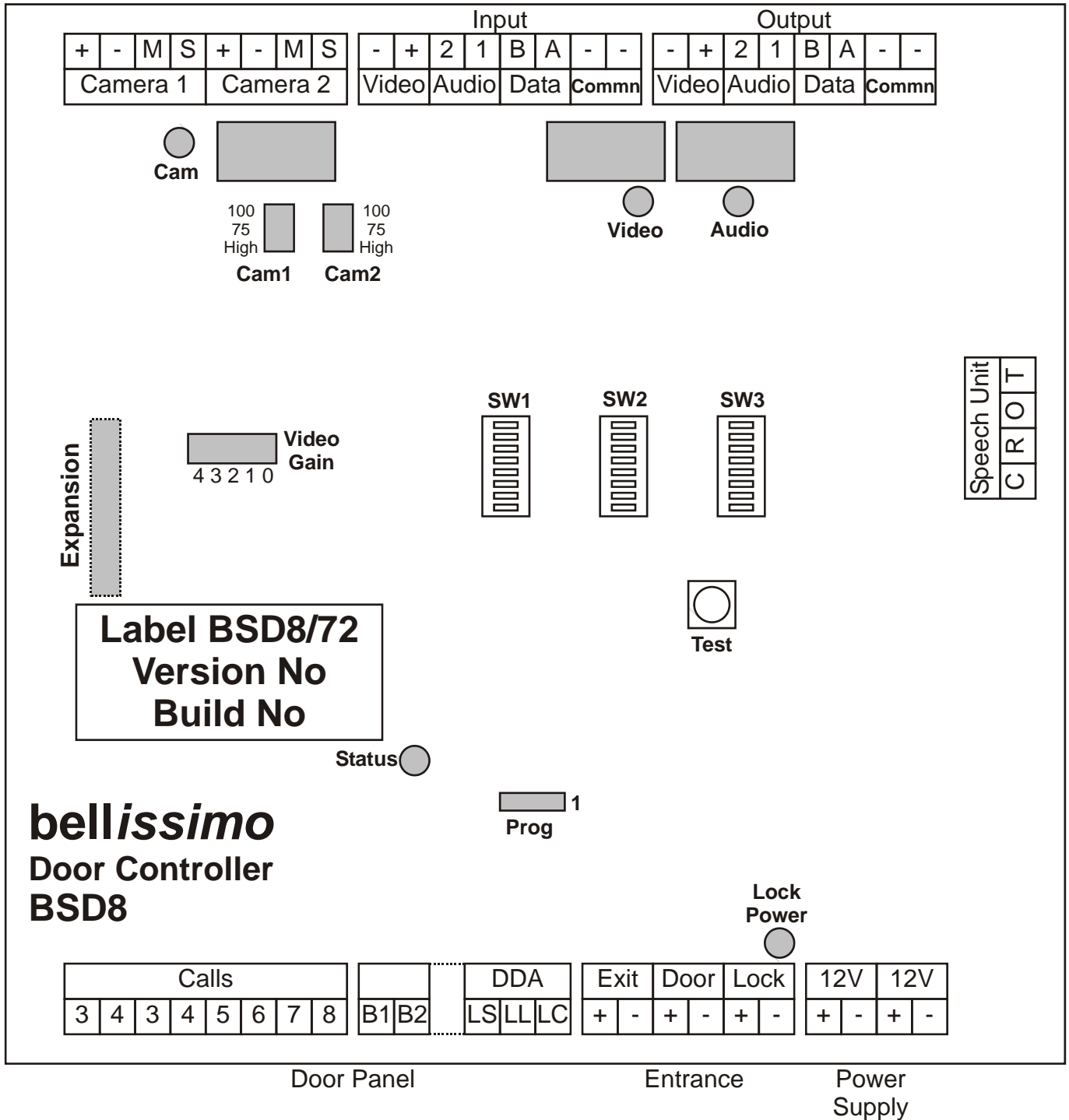



# bellissimo 2-72 Way Video Entry System

## Diagram E – 2-72 Way Multiple Entrance Wiring Detail

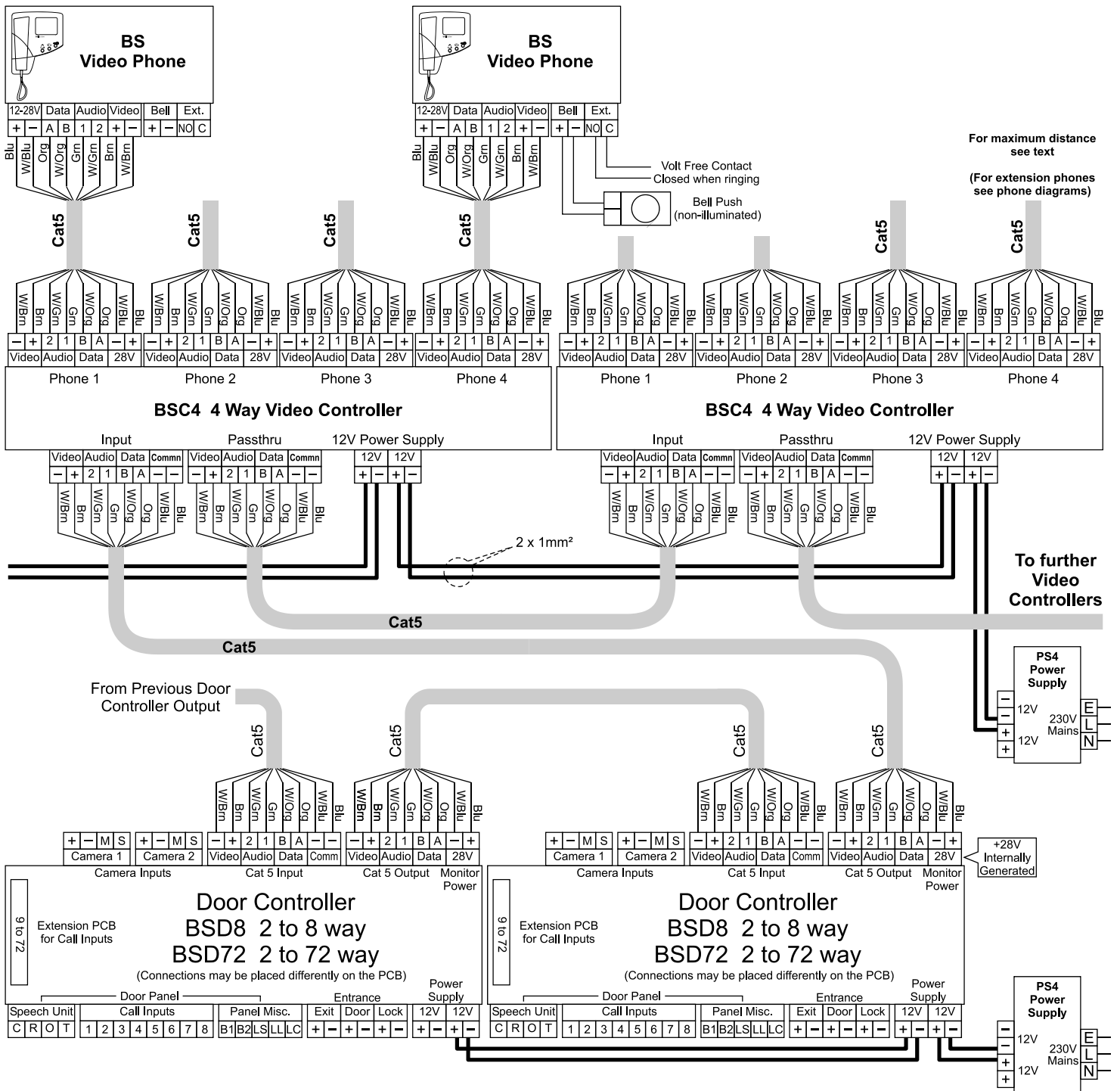



# bellissimo 2-72 Way Video Entry System

## Diagram F – Extension Videophone Wiring

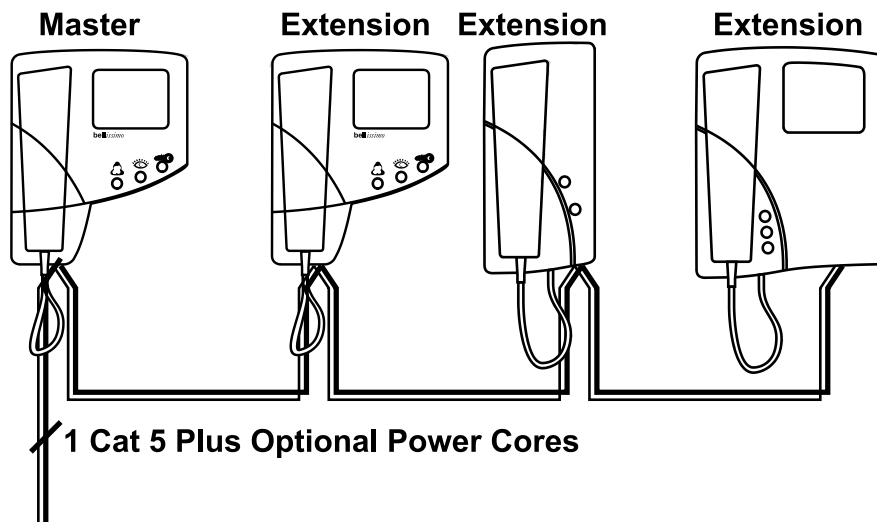

When alternate power wires are required replace Blu and W/Blu with the alternate wires.

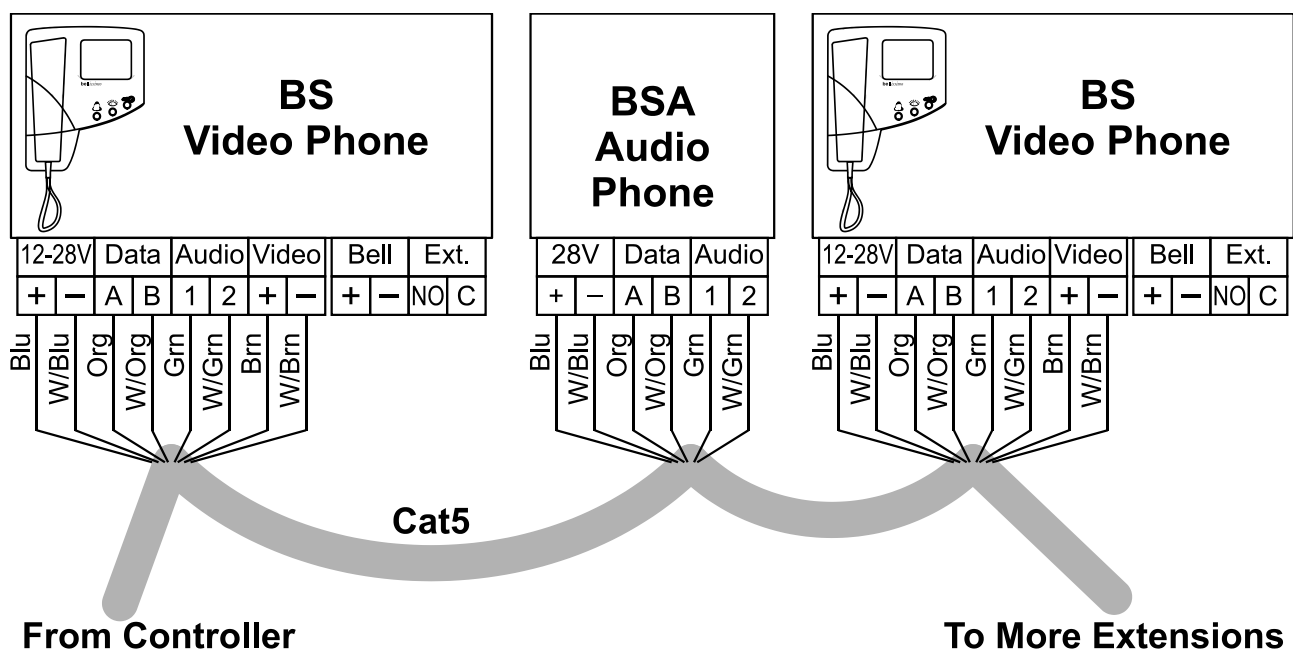

**Note. For each cable run :-**

- Only one unit must be Master (Recommend the first unit)
- Auto display on one video unit only (For auto display on multiple video units see next Diagram)
- Extension video units must be "daisy chain" wired to preserve video quality
- The last (or only) video unit on the cable requires the Video Terminator "ON"
- all other video units must have the Video Terminator "OFF"

# bellissimo 2-72 Way Video Entry System

## Diagram G – Videophone Local Power Wiring

Where more than one extension video unit is required to provide "auto display" then additional power supplies will be required

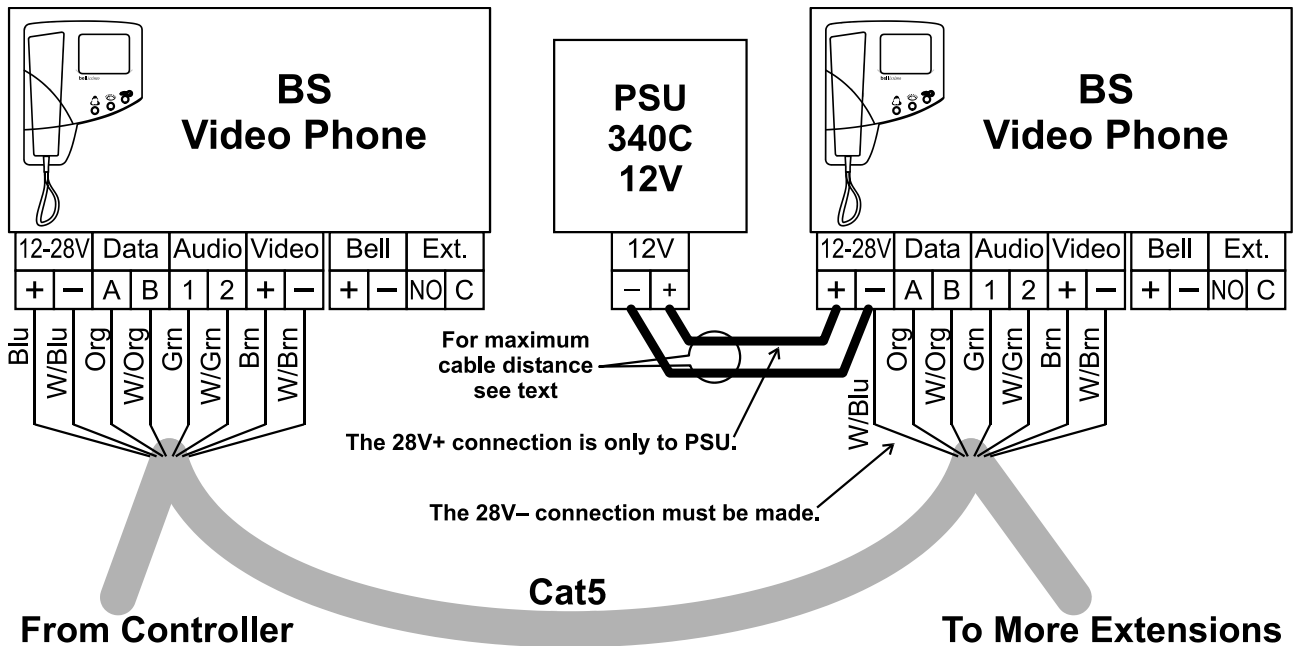
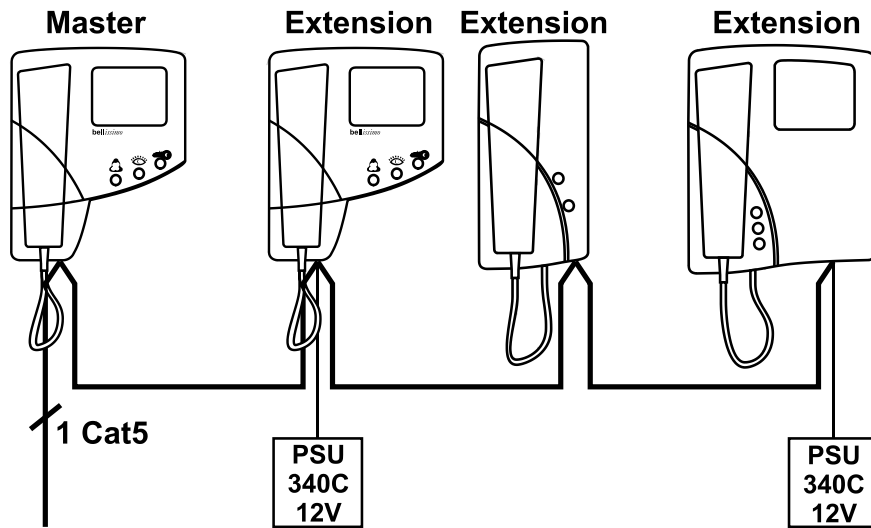

### Note. For each cable run :-

- Only one unit must be Master (Recommend the first unit)
- Extension video units must be "daisy chain" wired to preserve video quality
- The last (or only) video unit on the cable requires the Video Terminator "ON"
- all other video units must have the Video Terminator "OFF"

# bellissimo 2-72 Way Video Entry System

## Diagram H – Videophone Connections

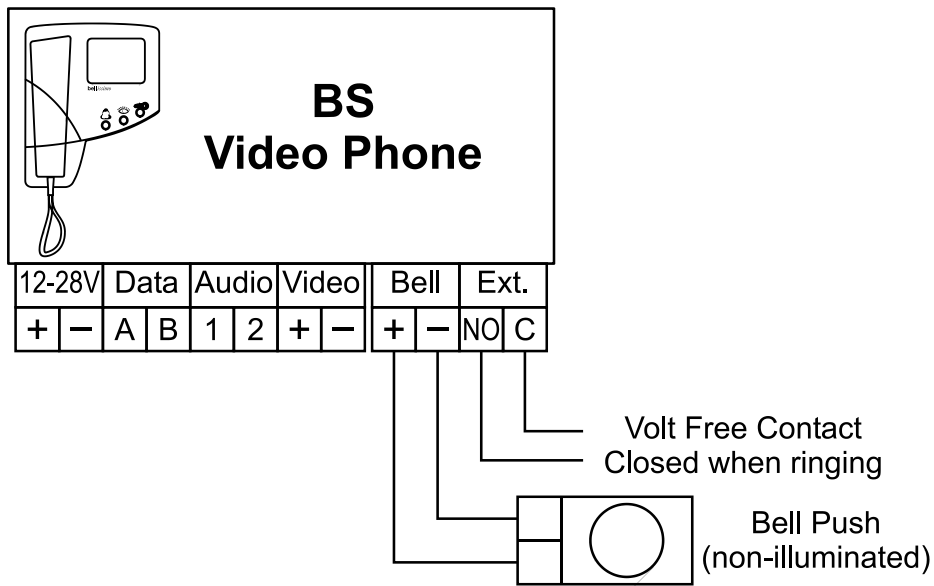

### Local Bell Connection

This is for a standard bell push with volt free contacts, or any other volt free contact. An illuminated bell push is not catered for.

### Auxiliary Ring Circuit

Primarily included for activating third party DDA devices the auxiliary ring output consists of a pair of volt free contacts which close while the phone is ringing.

If the phone is muted the contacts do not close even though the phone may flash to indicate ringing.

The contact rating is 1A non-inductive load.

# bellissimo 2-72 Way Video Entry System

## Diagram I – Option Details

### Camera Termination Options

Cameras may be wired in either twisted pair or coax and shared with other equipment.

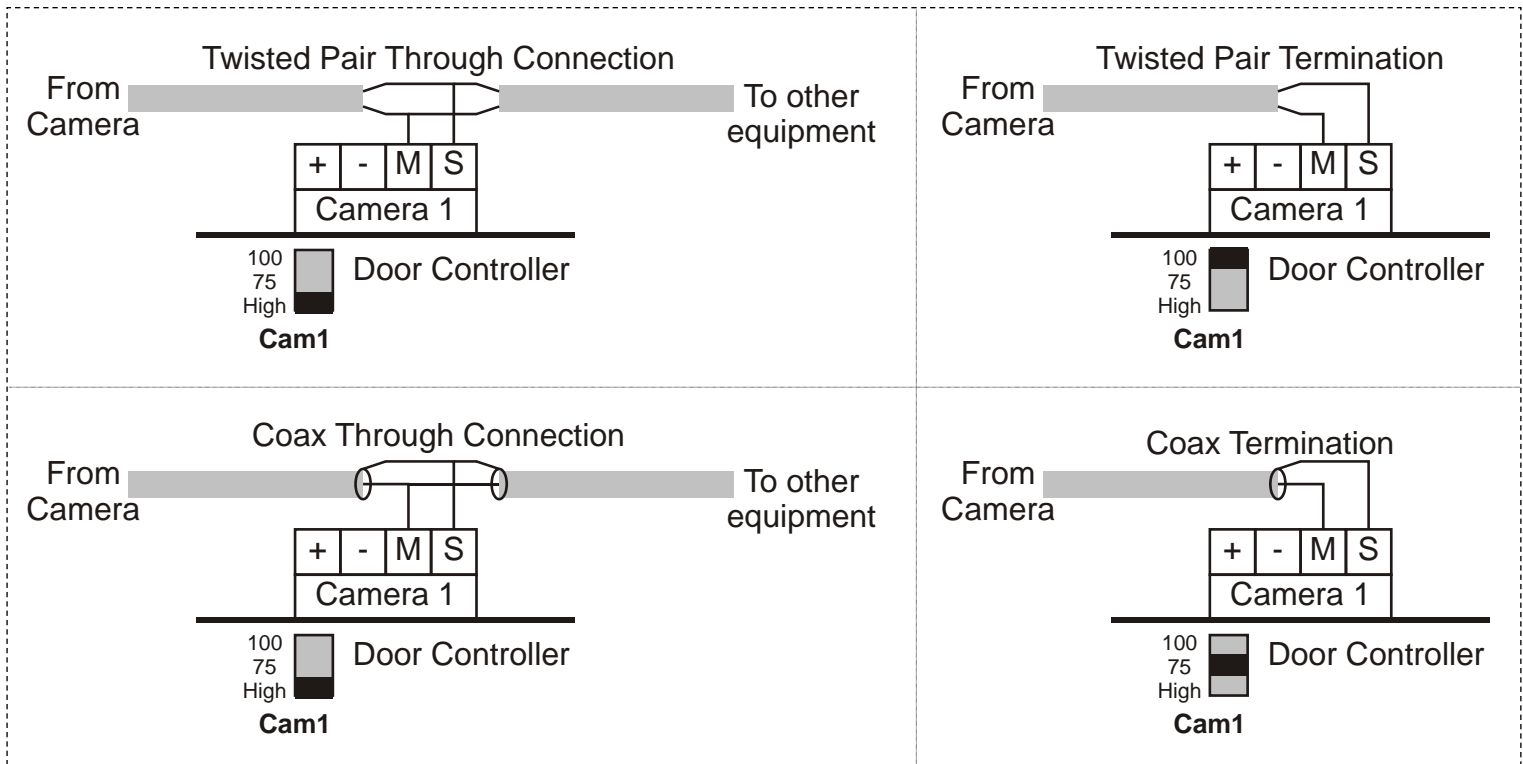

### Time Clock Sharing

A time clock can be shared between distributed equipment areas by borrowing one of the 'comm -' wires in the interconnecting Cat5 to use as the shared "Time clock common".

The "Time clock common" signal is sharable across all Bell controller types.

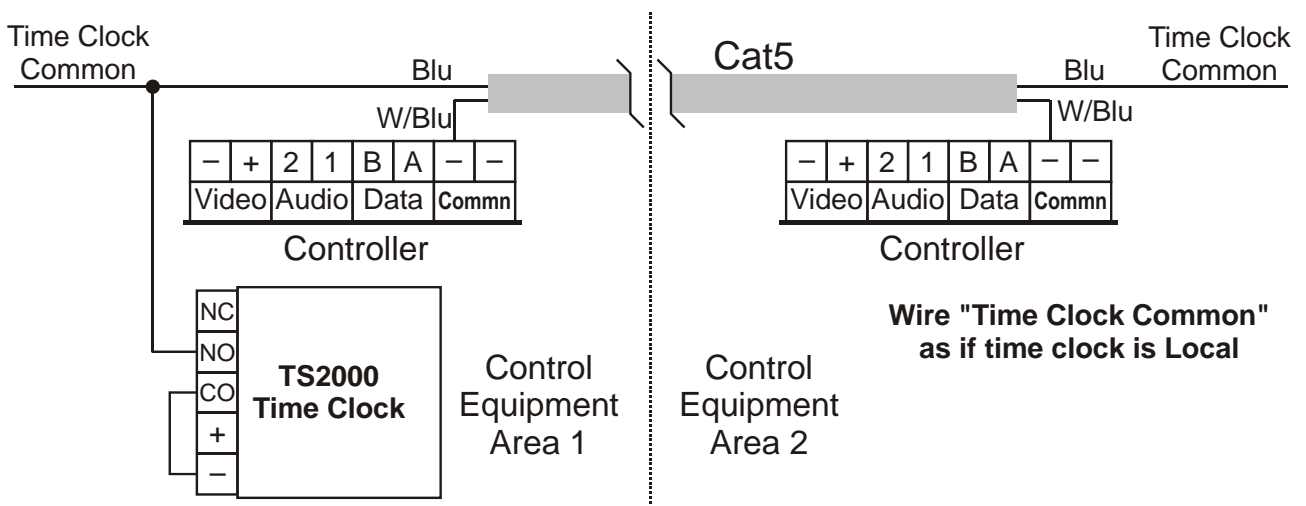

# bellissimo 2-72 Way Video Entry System

## Diagram J – 2-72 Way Additional DDA Wiring

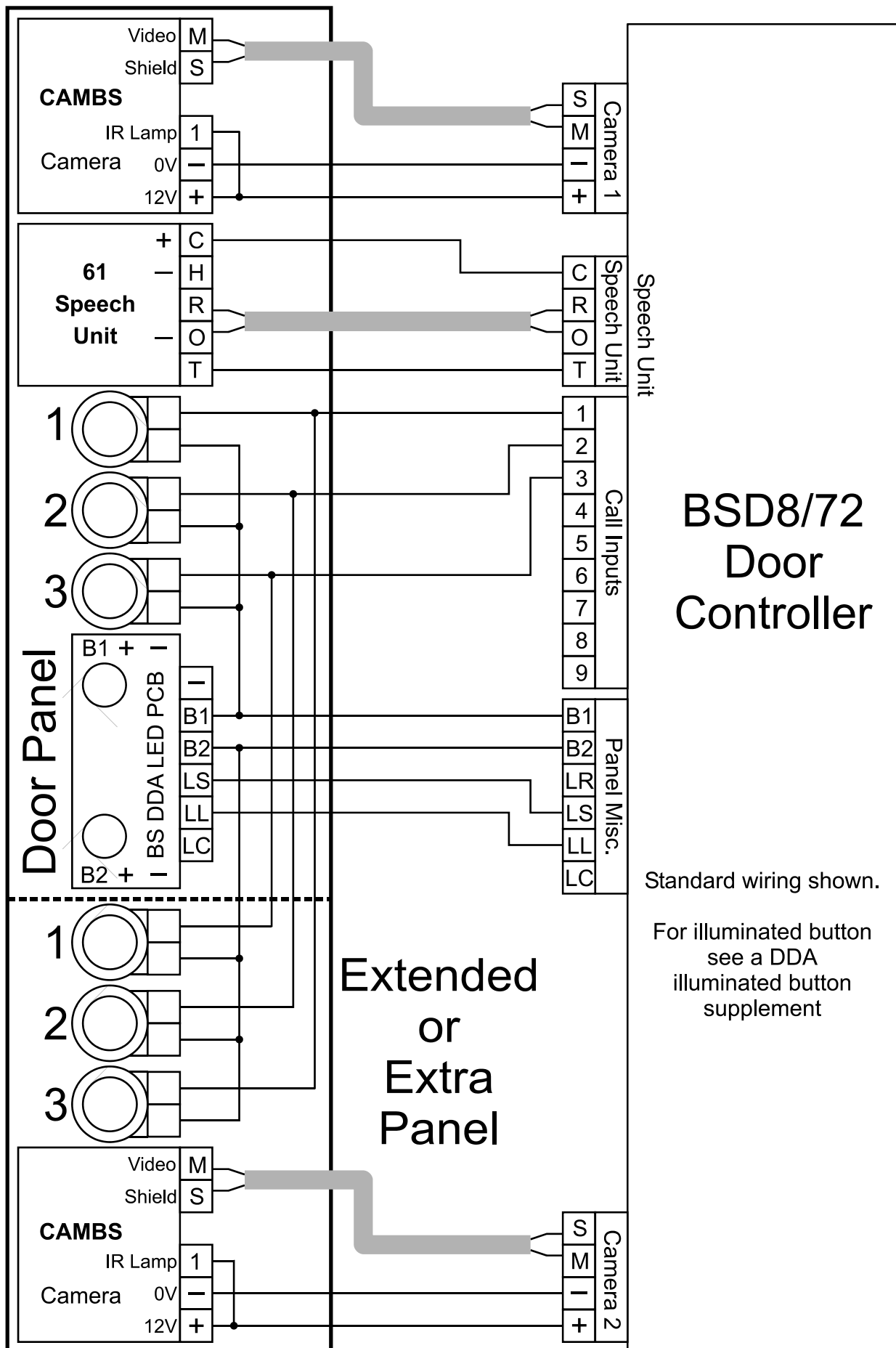

# bellissimo 2-72 Way Video Entry System

## Diagram K – bellissimo Combined System Connections

### Connecting a Bellcode Coded Access Controller

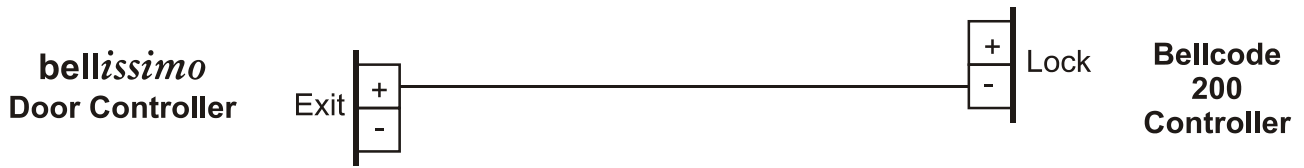

Connect the lock release as per this manual. Leave the Bellcode controller set to fail secure, the BSD controller sets the lock type.

See "Bellcode Manual inc CK200 CS109 (PD-078)" for the other installation and setting instructions.

- Note 1. A normally open exit button can still be wired to the Bellcode unit in addition to the bellissimo wiring.
- Note 2. A "12V -" connection will be required if the 2 units are not sharing a power supply.

### Connecting a Bell PAX1 Proximity Reader

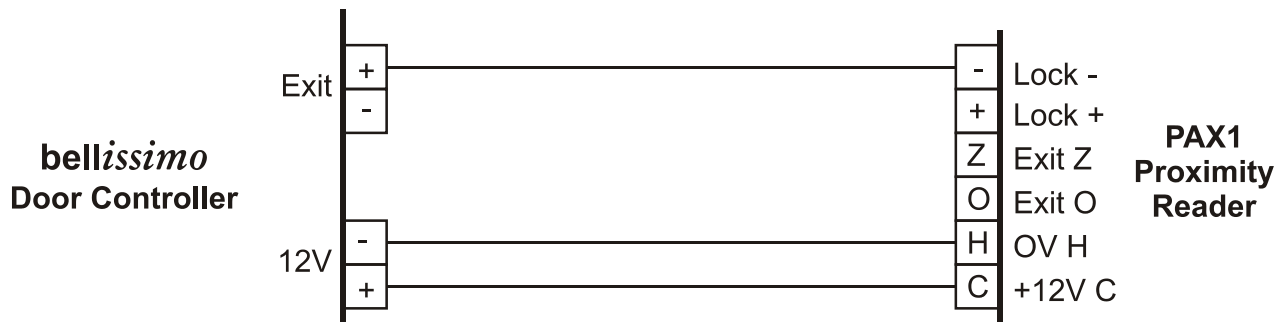

Connect the lock release as per this manual. Leave the Proximity Reader set to fail secure, the BSD controller sets the lock type.

- Note 1. A normally open exit button can still be wired to the BSD controller in addition to the proximity wiring.

### Opening a Gate or Locks on Third Party Systems

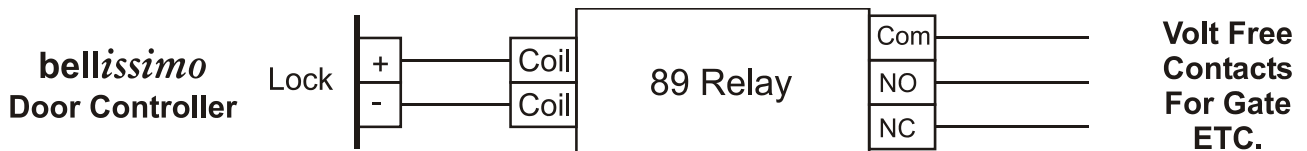

Leave the BSD controller set to Fail secure.

Use COM and NO or COM and NC as required for the gate controller or third party access system.

# bellissimo 2-72 Way Video Entry System

## Diagram L – ACT Proximity to bellissimo Connections

### ACT 1000/2000/3000 Proximity Controller

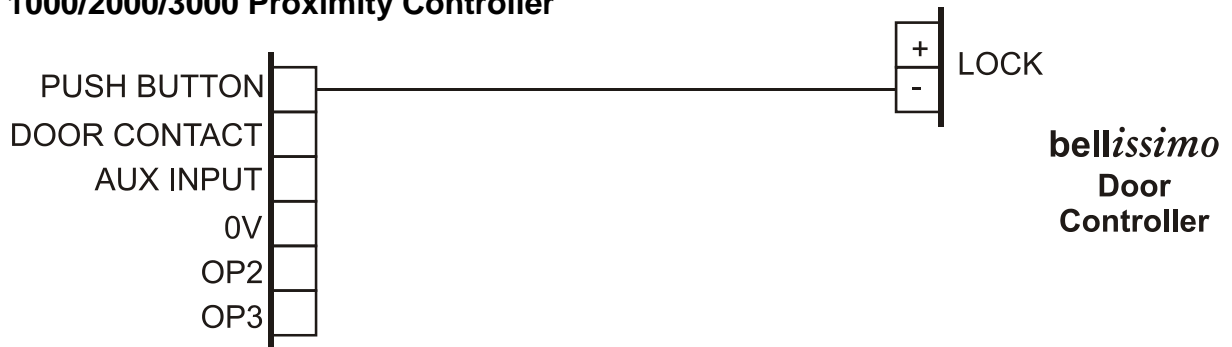

### ACT 100e Proximity Extender



### Notes

1. Connect the lock release or Maglock using the ACT Manuals.
2. Leave the BSD controller set to Fail Secure regardless of the type of release used.
3. A normally open exit button can still be fitted to the ACT controller in addition to the bellissimo wiring.
4. If the 2 units are not sharing a power supply, then a connection from BSD controller 12V - to ACT 0V will be required.
5. Look for the notes on the ACT installation diagram concerning the use of links when the door contact is not used and when a power supply without power fail is not used.

# **bell*issimo* 2-72 Way Video Entry System**



# **bell*issimo* 2-72 Way Video Entry System**

# bellissimo 2-72 Way Video Entry System

## Safety Information and Declarations

Connections to the 240VAC mains supply must be carried out by a qualified electrician or similar competent person, and made in accordance with current legislative requirements. A two-pole switch (as provided by a Consumer Unit or Switch-Fuse) must be included to isolate both Live and Neutral during Installation or Maintenance. The circuit must be protected by a fuse or other current-limiting device, rated according to the capacity of the cable used, up to a maximum of 10A. Use only mains cable to BS6004 or equivalent, within the following specified limits:

	Min	Max
Conductor Diameter	1.0mm (0.8mm <sup>2</sup> )	2.25mm (4mm <sup>2</sup> )
Cable Diameter	4.0mm	8.0mm

### Model 840 Power Supply (with battery standby)

The Model 840 power supply must be placed in a protected indoor environment such as an electrical cupboard. It must be secured to the wall with adequate fixings so that there is no possibility of it falling. The lead-acid battery for the standby power supply is shipped in separate packaging. It should only be connected once the system has been fully tested. Connection is made by 2 leads with spade terminals; observe the correct polarity - red to positive, black to negative. Care must be taken to ensure that the terminals of the battery are not shorted together by metal objects, as this may constitute a Fire Hazard. The Control Cabinet is IP55 rated (to exclude dust) and is vented to avoid the build-up of gases. Do not block any vents that may be apparent.

A good mains safety earth must be connected to the cabinet housing the power supply

Where the power supply is fitted with a replaceable internal mains fuse and or battery fuse, always replace with the same type as indicated on the power supply. The fuse must be approved to BS EN 60127 or equivalent.

Power Supply Model	Mains Fuse (Time Delay)	Battery Fuse (Quick Blow)
840	T2A 20mm HBC (HRC) Ceramic	F4A 20mm Glass

### Model PS4 and 340C Power Supplies

These power supplies must be wall-mounted onto plasterboard, or a similar non-conductive material, in a protected indoor environment such as an electrical cupboard.

When fitting the power supply cable (both mains and low voltage) ensure the cable entry cut-outs in the enclosure lid are no larger than necessary for the cable diameter used and under no circumstances must they be taken beyond the outer cut-out zones.

# bellissimo 2-72 Way Video Entry System

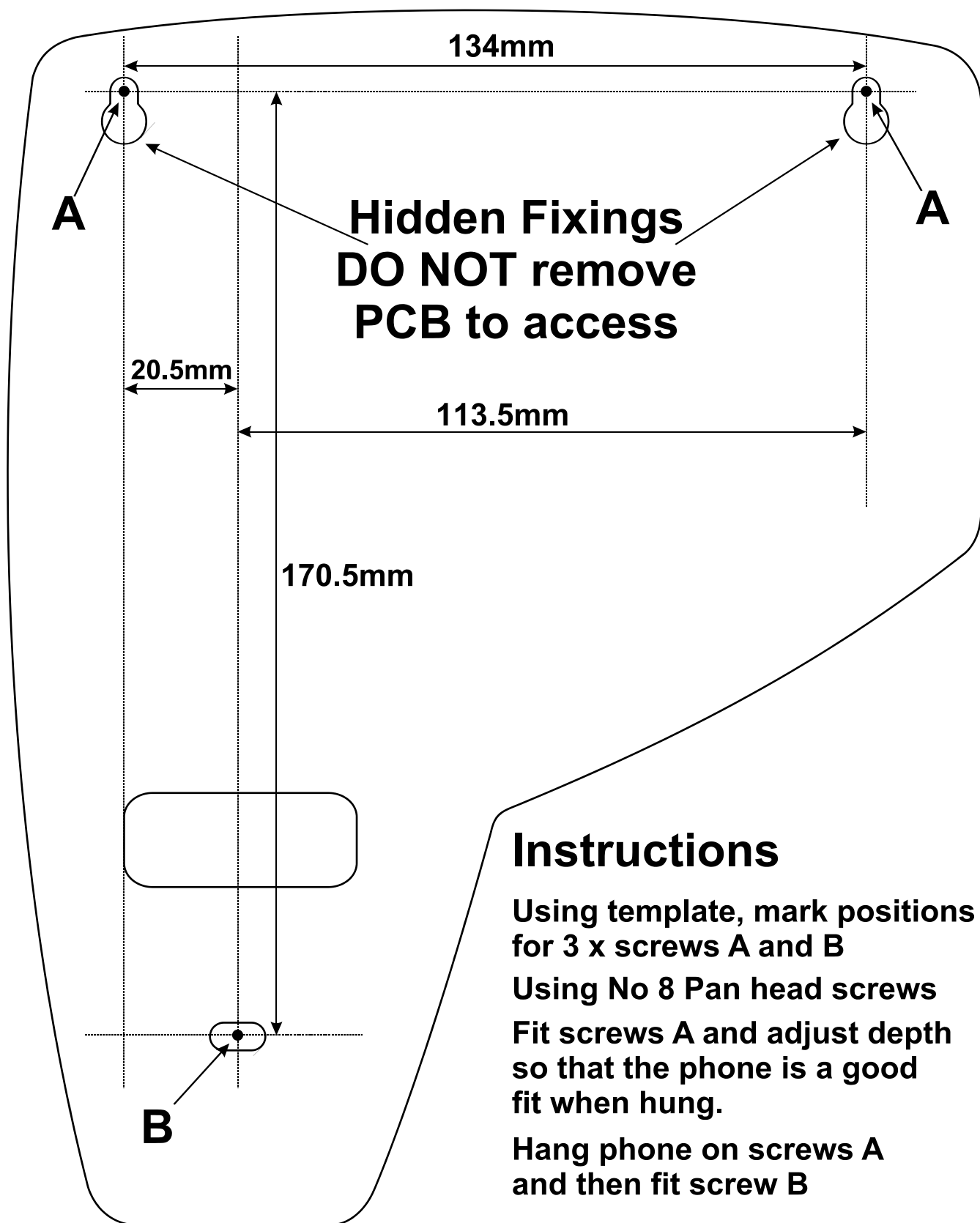

# bellissimo 2-72 Way Video Entry System

## Bell System (Telephones) Ltd.

Presley Way,  
Crown Hill,  
Milton Keynes  
MK8 0ET.

Tel: 01908 261106 (Sales and Technical Support)

FAX: 01908 261116

OR

Local rate numbers

Tel: 0845 121 4008 (Sales and Technical Support)

FAX: 0845 121 4009

E-mail: [sales@bellsystem.co.uk](mailto:sales@bellsystem.co.uk)

[technical@bellsystem.co.uk](mailto:technical@bellsystem.co.uk)

Website: [www.bellsystem.co.uk](http://www.bellsystem.co.uk)

## Standards

This product complies with European directive 89/336/EEC on  
Electromagnetic Compatibility and Low Voltage Directive 72/23/EEC.

Emissions: Generic BSEN 61000-6-3

Immunity: Generic BSEN 61000-6-1

Low Voltage: Generic BSEN 60950



**bell**  
**system**  
(Telephones) Ltd



BS EN ISO 9001:2008 Certificate number GB2000389