

ALP200H-YD30

Architectural Hardware

The Alpro ALP200H also known as the Cobalt YD30 is a revolutionary low voltage motor driven electronic lock for 180° swing doors. It has been designed to secure double action doors and addresses the two biggest issues in door locking; the ability to align a misaligned door and the ability to release when requested, even with excessive load on the door. The ALP200H is typically used in commercial doors and controlled by access control systems.



Door Alignment

Door misalignment of up to +/- 8mm is automatically corrected

Side Load Release

The door can have in excess of 100kg being applied and it will still release instantly when requested

Simple Configuration

Convert from fail safe to fail secure by repositioning a single jumper

High Security

Automatic deadlocking
10,000N holding force (1,000kg)
Two, 10mm thick stainless steel bolt pins

Electrical Specification

Input voltage from 12vDC-24vDC
Less than 50mA standby current
Reverse polarity and transient protection
Multiple attempts to lock

Dual Monitoring

Door and bolt position monitors

Versatile Installation

Mortice mount horizontally or vertically, on double action doors
Surface mount using the ALP200H accessories, including mounting onto glass

Physical Dimensions

255mm (L) x 30mm (W) x 51mm(D)

Certifications

EN61000-6-1: 2007
EN61000-6-3: 2007 + Amendment 1: 2001
FCC Part 15, subparts A and B



- Reliable • Secure
- Convenient

Ordering Information/Specifications

Surface mounting a lock and/or strike with the aid of the ALP210H accessories offers more flexibility in installation and makes securing glass doors possible. Dress plates are offered to give a 'clean' finish when a housing has been installed onto glass. The housing and dress plate are supplied with self-adhesive tape for instant application to glass doors and frames.

Description	Code
Cobalt electronic lock and strike plate	41ALP200H
Accessories	Code
Cobalt strike plate – 255mm (L) x 30mm (W) x 14mm (D)	41ALP203H
Cobalt housing with tape – 258mm (L) x 34mm (W) x 55mm (D)	41ALP204J
Cobalt dress plate with tape – 260mm (L) x 0.7mm (W) x 58mm (D)	41ALP206J

ALP200H Electronic Lock

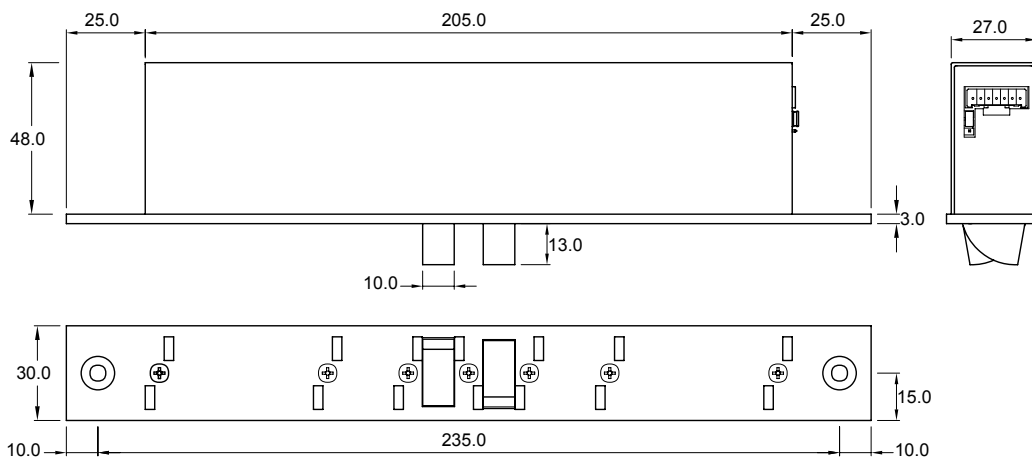

ALP203H Strike Plate

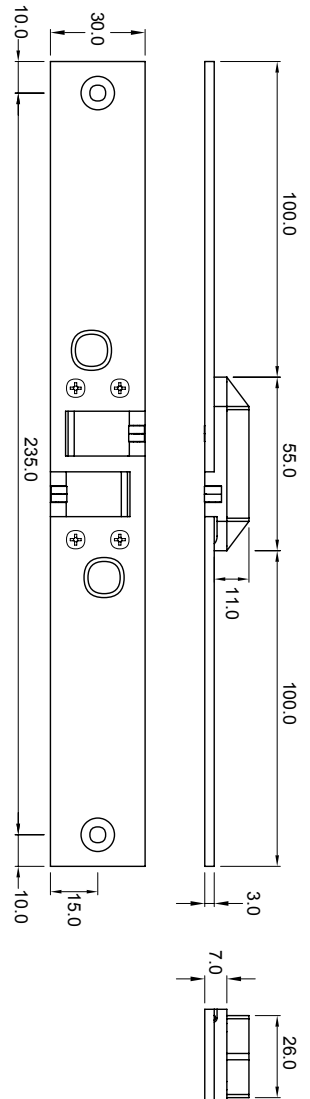

ALP204L Housing

