



Automatic barriers - GARD 8 series

FA01075-EN



EN English

G2081Z

INSTALLATION AND OPERATION

“IMPORTANT SAFETY INSTRUCTIONS FOR INSTALLATION”

“CAUTION: IMPROPER INSTALLATION MAY CAUSE SERIOUS DAMAGE, FOLLOW ALL INSTALLATION INSTRUCTIONS CAREFULLY”

“THIS MANUAL IS ONLY FOR PROFESSIONAL INSTALLERS OR QUALIFIED PERSONS”



1 Legend of symbols



This symbol indicates sections to be read with particular care.



This symbol indicates sections concerning safety.



This symbol indicates notes to communicate to users.

2 Destination and limits of use

2.1 Destination

The GARD 8 automatic barrier was designed for use in private or public car parks, in residential areas or in highly trafficked areas.



The use of this product for purposes other than as described above and installation executed in a manner other than as instructed in this technical manual are prohibited.

2.2 Limits of use

Passage width of up to 7.60 meters with a 4 second aperture time.

3 Standard followed

Came Cancelli Automatici is ISO 9001:2000 and ISO 14001 Quality and Environmentally certified. Came entirely designs and manufactures its products in Italy. The product in question compliant to the following legislation: *see Declaration of Compliance.*

4 Description

4.1 Gearmotor

G2081Z was designed and manufactured by CAME CANCELLI AUTOMATICI S.p.A. and is compliant with safety regulations in force. The cabinet is made of 2.5 mm painted galvanized steel. Inside the cabinet, the electromechanical gearmotor operates with a container for electric board and transformer.

Built with a anti-shearing safety system, it includes a safety contact in the inspection hatch lock.

The GARD 8 automation system is supplied with the following accessories:

G02000 - White-painted tubular aluminium rod, 2m (Ø 100 mm) complete with transparent slot cover;

G04000 - White-painted tubular aluminium rod, 4m (Ø 100 mm) complete with transparent slot cover;

G06000 - White-painted tubular aluminium rod, 6m (Ø 100 mm) complete with transparent slot cover;

G02040 - Ø 40 (yellow) balancing spring;

G04060 - Ø 50 (green) balancing spring;

G06080 - Ø 55 (red) balancing spring;

G06802 - Reinforcement for boom

G06803 - Telescopic joint and additional insert to attach the bar (this is obligatory for accesses of over 3.6m);

The following accessories are optional to the GARD 8 automation system:

RSE - Board for combined battery operation control and/or compass;

G02801 - Flashing dome lamp;

G02802 - Support for mounting the photoelectric cell (DIR) onto the cabinet (not applicable to barriers with bar and rack and/or mobile foot);

G028401 - Luminous cord for movement signalling;

G028402 - Luminous cord connecting cable;

G02807 - Fixed barrier support (obligatory for accesses of over 4m);

G02808 - Mobile barrier support (obligatory for accesses of over 4m);

G02809 - Red reflector strips (package of 20);

G0465 - Aluminium skirt (2 m modules);

G028011 - Door break-out bar bracket.

WARNINGS!

001G02802 Not for barriers fitted with 001G0465 skirt or 001G02808 swing-leg.

001G02808 For passage widths of max 7 m.

001G02807 For passage widths of over 7 m the swing-leg is mandatory.

001G0465 - 001G02808 cannot be used together.

Important! Check that the safety equipment and accessories are CAME originals; this is a guarantee that also makes the system easy to set up and upkeep.

4.2 Technical information

GEARMOTOR

Power supply: 230V A.C. 50/60Hz
 Motor power supply: 230V A.C. 50/60Hz
 Max. absorption: 2.8A
 Condenser: 35µF
 Rated power: 330W
 Max. torque: 250 Nm

Reduction ratio: 1/202
 Opening time: 8 s
 Operative intermittence: 30%
 Protection level: IP54
 Weight: 91 kg
 Insulation class: I



4.3 Parts description

AUTOMATION UNIT

1. Dome cover
2. Motor shaft plate
3. Intermediate plate
4. Boom-attachment cover
5. Anti-shearing protective cover
6. Cabinet
7. Casing for key-switch and digital selectors
8. Control panel
9. Lever arm
10. Boom-adjustment stopper
11. Transmission connecting rod
12. Gearmotor with encoder
13. Inspection hatch
14. Anchoring plate
15. Clamp
16. Adapter with gasket for SEL-series selectors

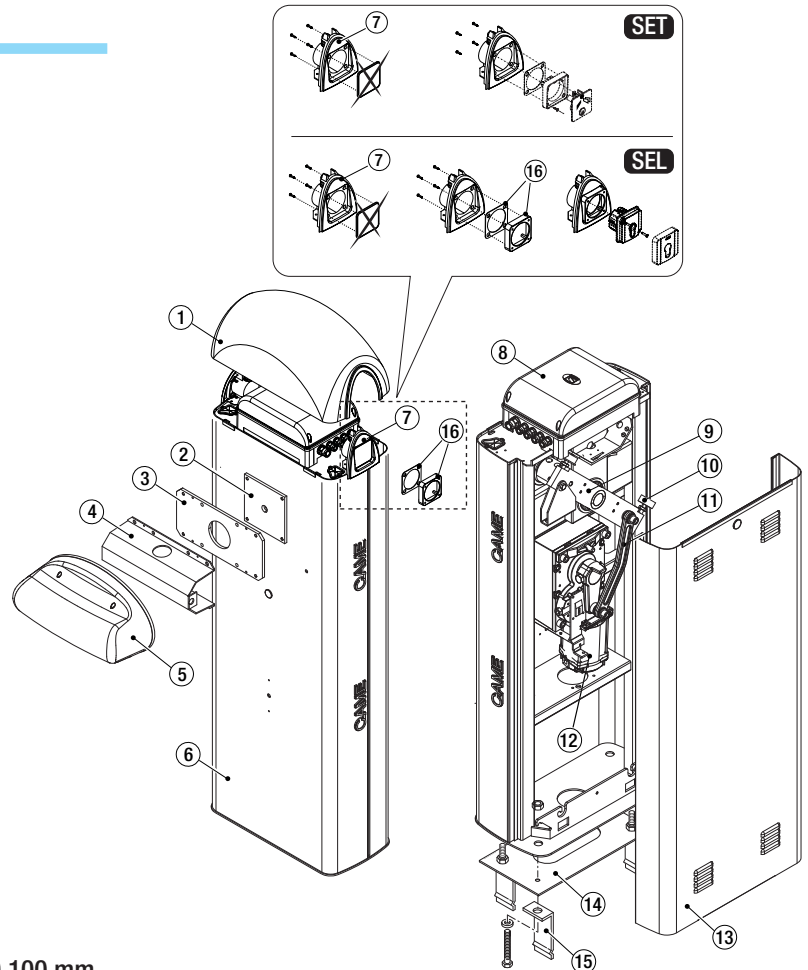

ACCESSORIES

- 1) G02000/G04000 - Aluminium bar, painted white, Ø 100 mm
- 2) G02040 - Ø40 (yellow) balancing spring
- 3) G04060 - Ø50 (green) balancing spring
- 4) G06080 - Ø55 (red) balancing spring
- 5) G02806 - Rack
- 6) G02802 - Support for DIR photoelectric cells
- 7) G028401 - Luminous cord
- 8) G02807 - Fixed barrier support
- 9) G02808 - Mobile barrier support
- 10) G02809 - Adhesive reflector strips
- 11) G02801 - Flashing dome lamp
- 12) G06803 - Telescopic joint and additional insert to attach the bar.

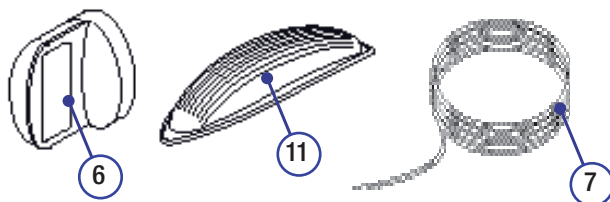
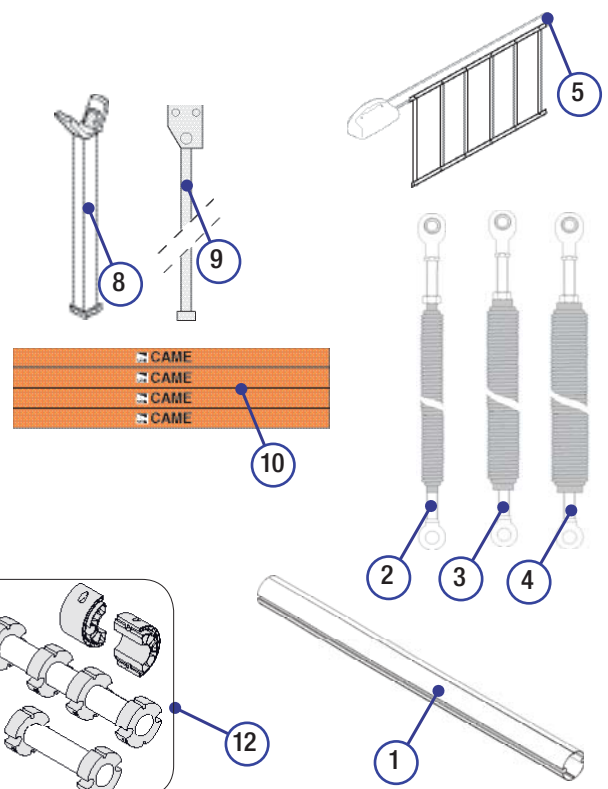

4.4 Size measurements

Measurements in mm

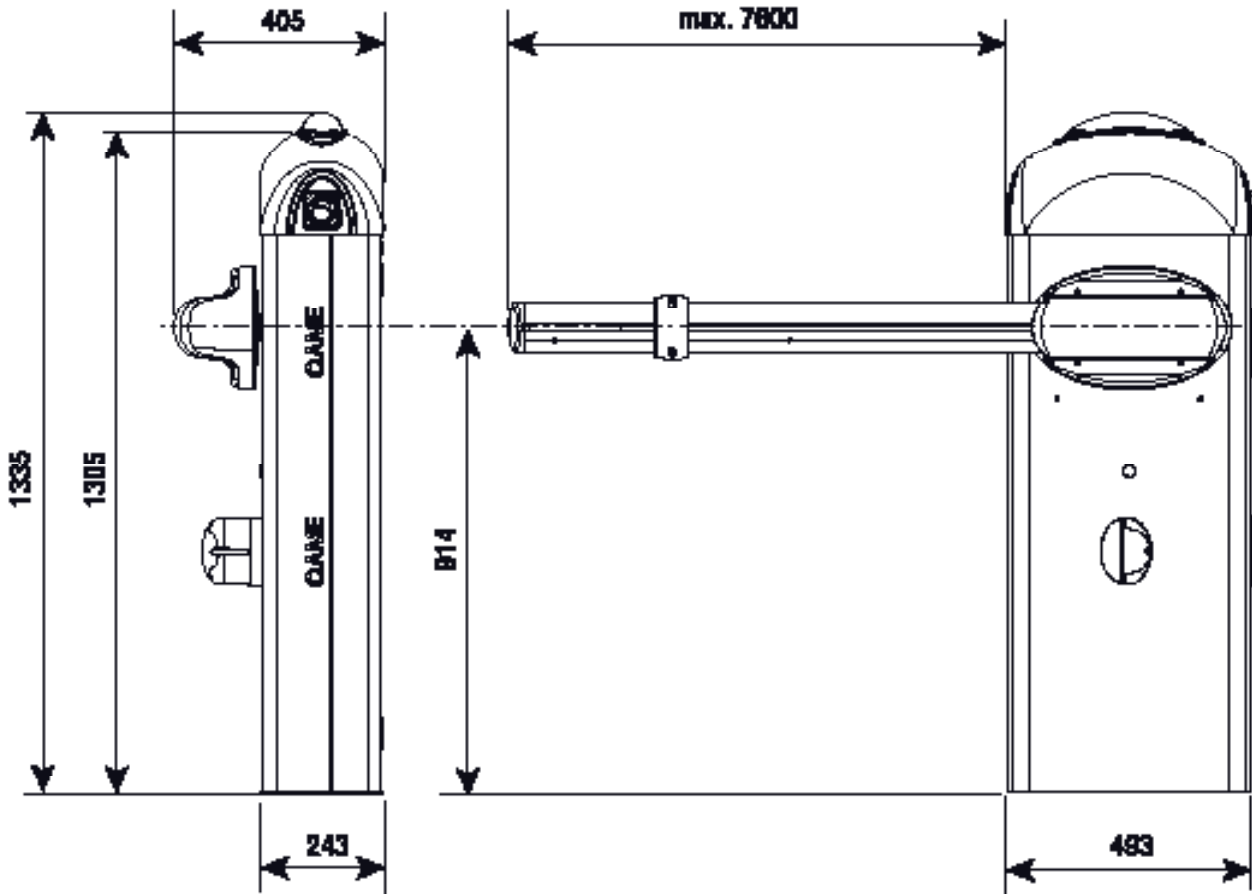

5 Installation

 Installation must be carried out by expert qualified personnel and in full observance of regulations in force.

5.1 Preliminary checks

 Before proceeding with the installation, it is necessary to:

- Make sure the area selected for the mounting of the base and for the unit itself presents no hazards;
- Provide for suitable omnipolar disconnection device with more than 3 mm between contacts to section power supply;
- \oplus Connections inside the case made for protection circuit continuity are allowed as long as they include additional insulation with respect to other internal drive parts;
- Install suitable tubes and ducts for electric cable passage to guarantee protection against mechanical damage;

5.2 Tools and materials

Make sure all tools and materials necessary are within reach to install the edge in maximum safety, according to regulations in force. The following figure illustrates the minimum equipment for the installer.



5.3 Cable list and minimum thickness

Connections	Type of cable	Length of cable 1 < 10 m	Length of cable 10 < 20 m	Length of cable 20 < 30 m
Alimentazione 230V	FROR CEI 20-22 CEI EN 50267-2-1	3G x 1,5 mm ²	3G x 2,5 mm ²	3G x 4 mm ²
Photoelectric cells TX		2 x 0,5 mm ²	2 x 0,5 mm ²	2 x 0,5 mm ²
Photoelectric cells RX		4 x 0,5 mm ²	4 x 0,5 mm ²	4 x 0,5 mm ²
24V power supply accessory		2 x 0,5 mm ²	2 x 0,5 mm ²	2 x 1 mm ²
Safety and control devices		2 x 0,5 mm ²	2 x 0,5 mm ²	2 x 0,5 mm ²
Antenna connection	RG58	max. 10m		
Metallic mass detector	(see documents provided with product)			

N.B.: An evaluation of the size of the cables with lengths other than the data in the table must be made based on the effective absorption of the connected devices, according to the instructions indicated by the CEI EN 60204-1 standards. For connections that require several loads on the same line (sequential), the size given on the table must be re-evaluated based on actual absorption and distances.

5.4 Standar installation

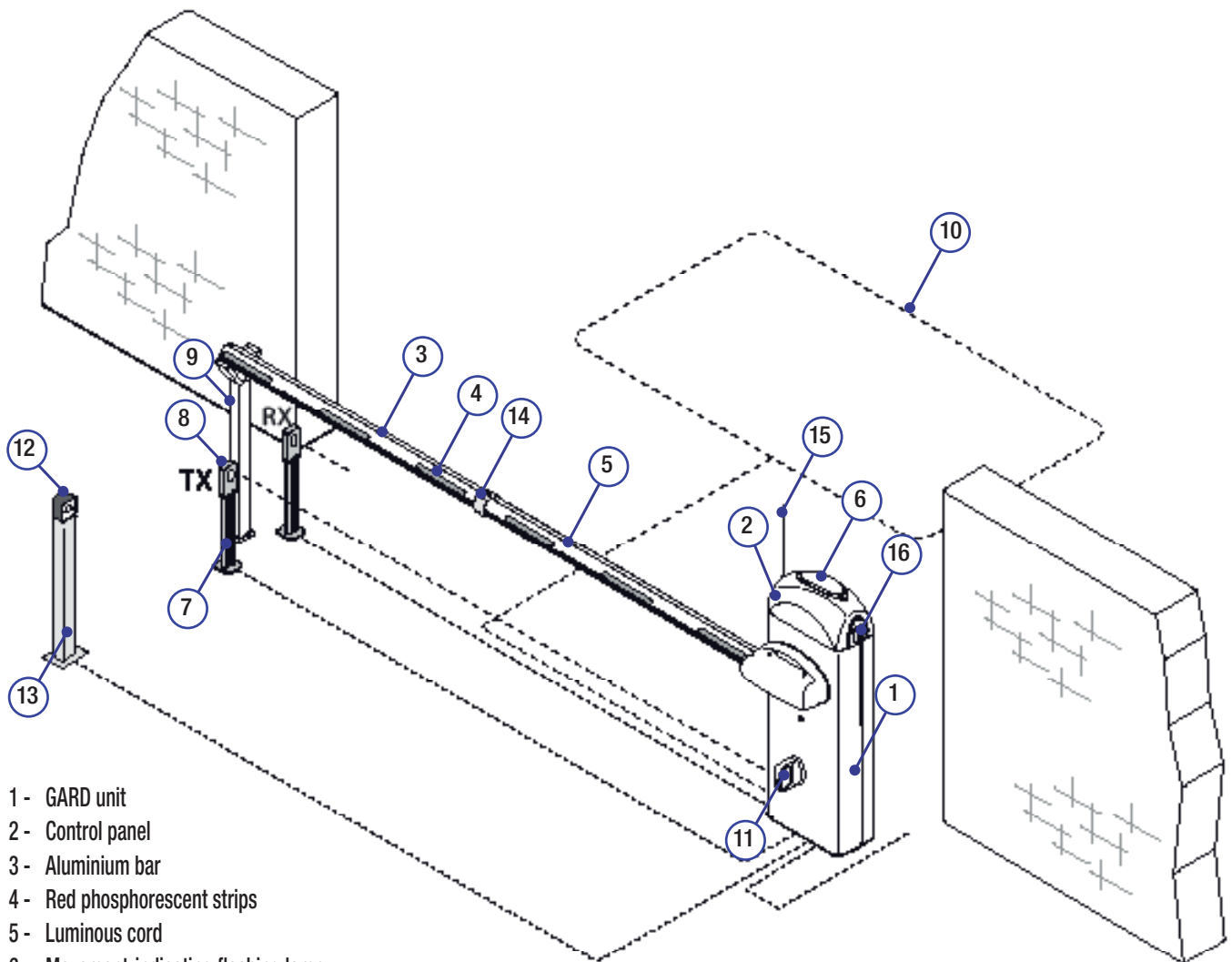

- | | |
|---------------------------------------|---|
| 1 - GARD unit | 12 - Command devices (Keyboard, magnetic key, card, etc.) |
| 2 - Control panel | 13 - Column for reader |
| 3 - Aluminium bar | 14 - Joint for rod |
| 4 - Red phosphorescent strips | 15 - Antenne |
| 5 - Luminous cord | 16 - Key-operated selector switch |
| 6 - Movement-indicating flashing lamp | |
| 7 - Column for photoelectric cells | |
| 8 - Photoelectric cells | |
| 9 - Fixed barrier support | |
| 10 - Magnetic sensor | |
| 11 - Photoelectric cell support | |

5.5 Fitting for unit base

 The following applications are only examples, as the space required for unit installation and the accessories vary depending on dimensions and therefore it is up to the installer to select the best solution.

- Prepare a hole to house the fixing base and prepare sheath tubes from the branch pit for the connections.
N.B. the number of tubes depends on the type of system and the accessories you will hook up.

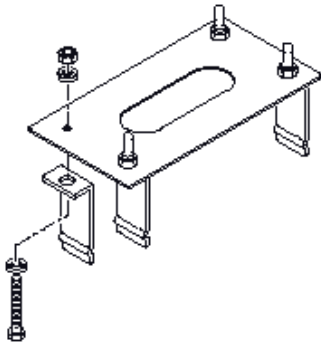
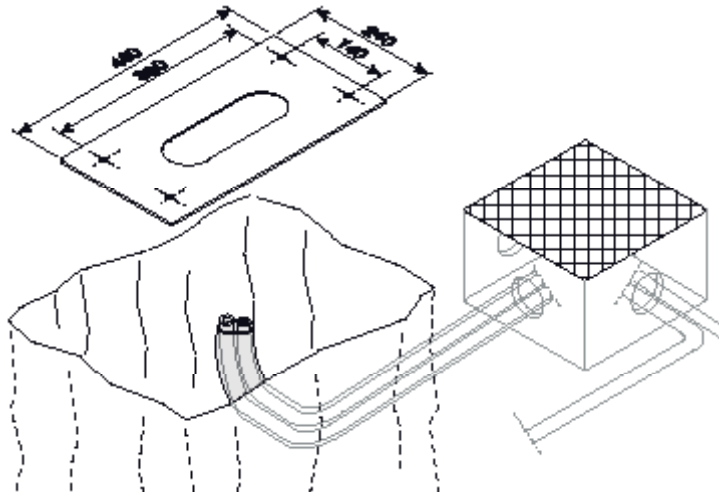

- Assemble the four anchoring clamps at the base.

- Fill the hole with concrete and immerge the clamps and the fixing base, paying particular attention to the sheath tube which must go through the hole at the base. The base must be perfectly level, clean and with the screw threads fully on the surface.

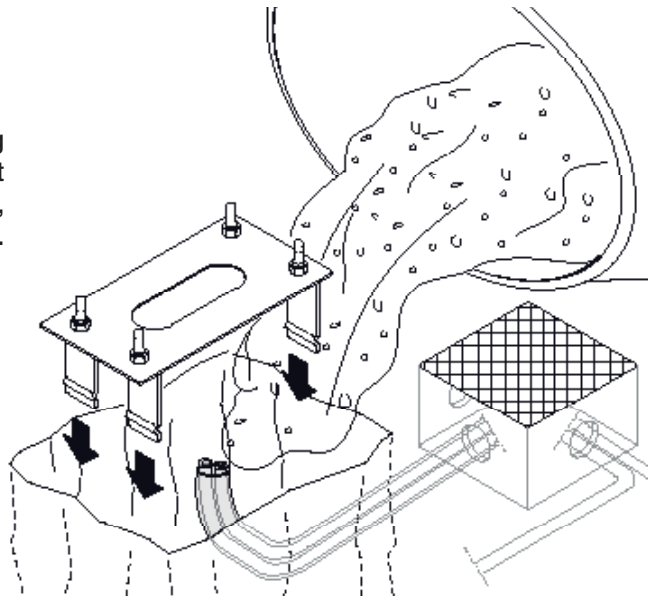

- Remove the nuts and washers from the threaded screws, position the cabinet on the base in correspondence with the 4 threaded screws and secure with the nuts and washers.

Note: We recommend installing the cabinet with the inspection hatch facing the internal area.

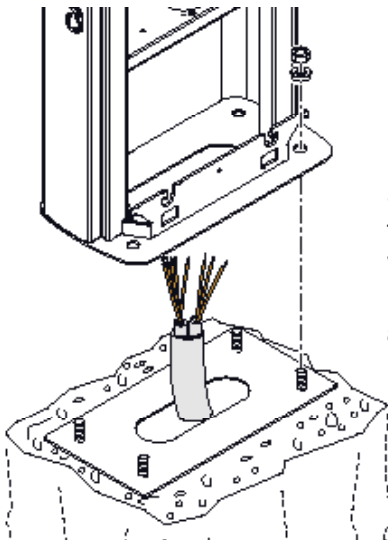

5.6 Installation of the Unit

- Remove the two screws at the upper dome's side and lift it.
- Insert the customised key in the lock, turn it counter-clockwise and remove the hatch from the cabinet.

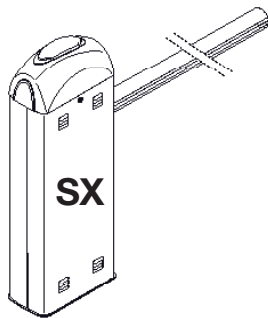
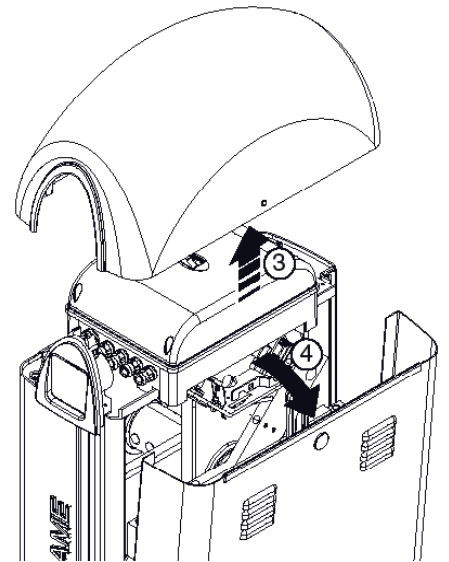
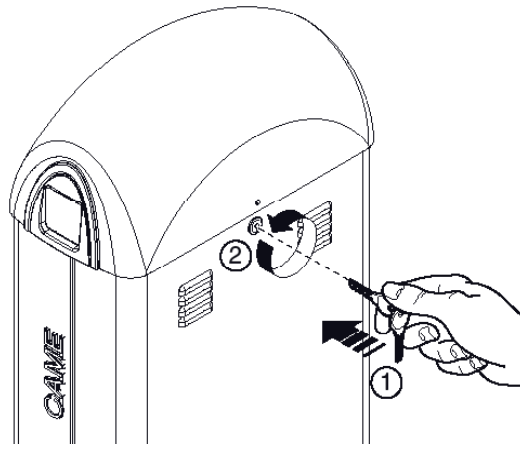

- The barrier is designed to be installed on the left of the gateway as seen from inside.

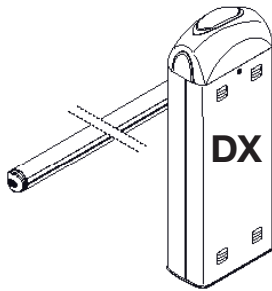

Should installation on the right be required, the direction of the bar's opening must be inverted. Proceed in the following manner:

- remove the spring securing bracket and the transmission rod from the lever arm;
- loosen the motor support grub screw;
- rotate the lever arm by 90°;

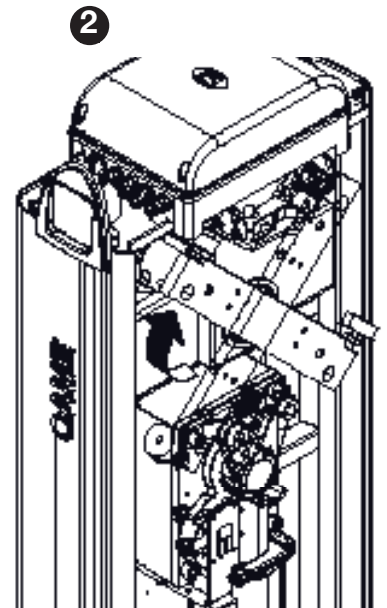
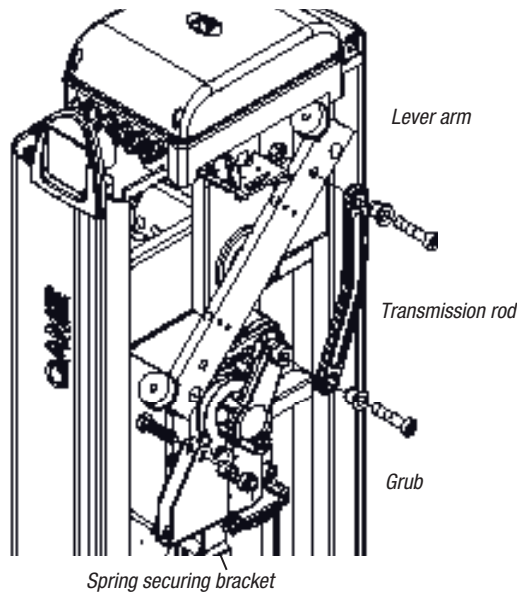

- Fix the spring securing bracket and the transmission rod on the side opposite that of lever arm;
- tighten the grub screw;
- invert the motor's U-V phases and the FA and FC endstop wires on the control panel terminal.

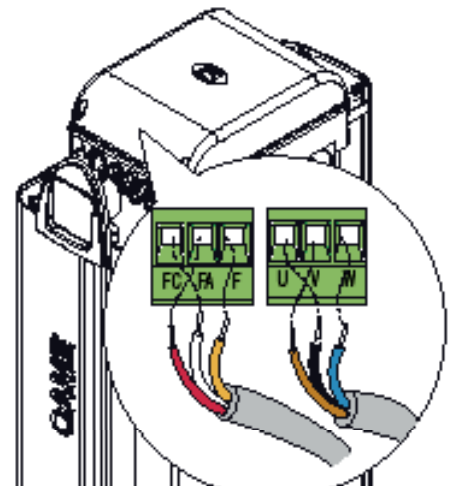
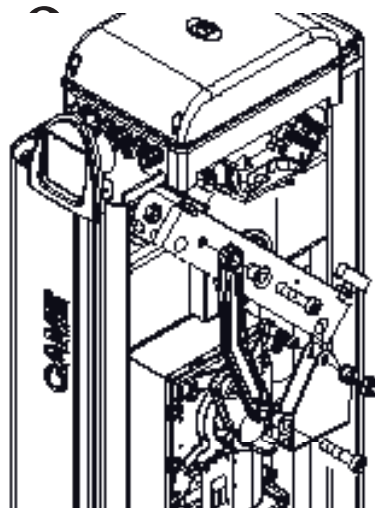

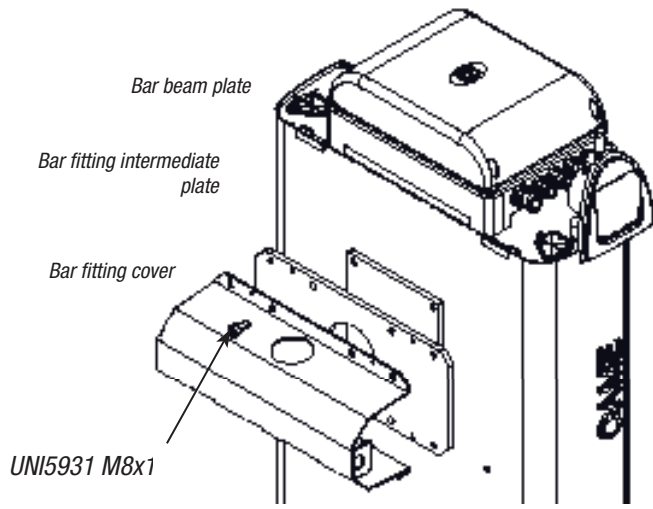

- Position the middle plate between the fitting plate and the bar-fitting cover, and put in one UNI 5931 M8x20 screw without tightening it to facilitate bar assembly.

- Insert the bar in the fitting cover and secure it with screws.

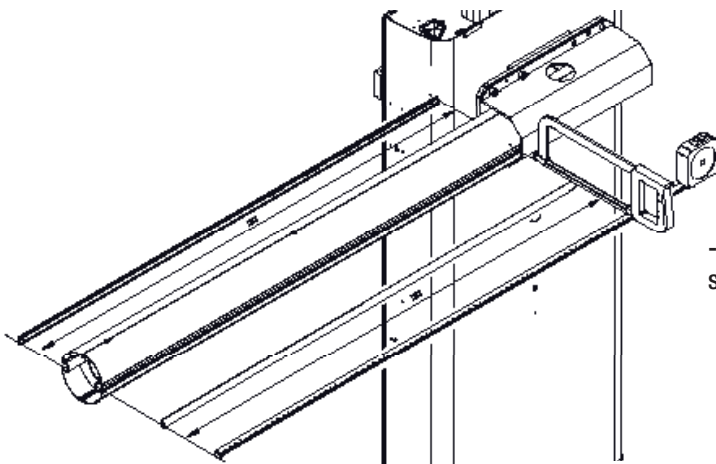
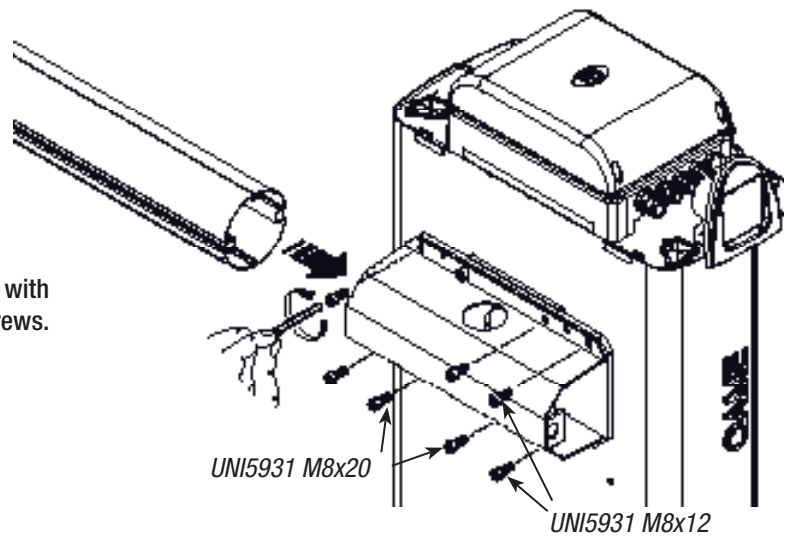

- Measure the length of the bar, cut the bar slot to the same length.

- Insert it in the bar's conduit, a procedure that should be carried out on both sides.
Insert the shock-resistant profile and cut excess length. Lastly, secure the bar end plug with the screws provided.

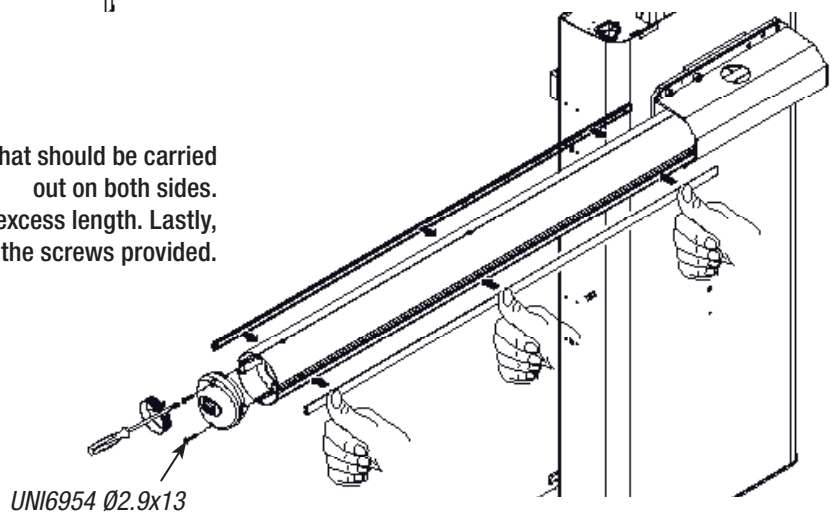

- Tighten the anti-shearing protection cover to the bar fitting with UNI6954 Ø3.9x19 screws.

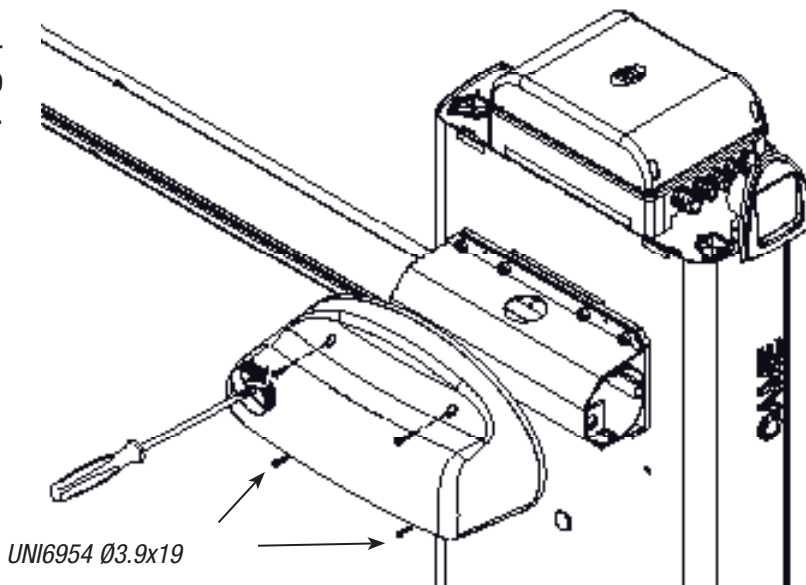

5.7 Bar balancing

- Prior to bar balancing, select a suitable spring depending on the situation at hand. See table below:

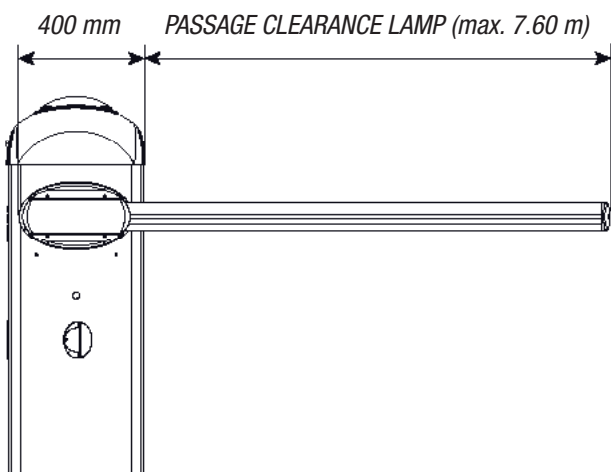

SPRING TYPES

- Spring G02040 $\varnothing_e = 40$ mm
- Spring G04060 $\varnothing_e = 50$ mm
- Spring G06080 $\varnothing_e = 55$ mm

Passage clearance lamp (m)

		2.0	2.5	3.0	3.5	4.0	4.5	5.0	5.5	6.0	6.5	7.0	7.6
Bare bar*	first spring	Yellow	Yellow	Yellow	Yellow	Green	Yellow	Yellow	Green	Green	Green	Red	Red
	second spring	Diagonal	Diagonal	Diagonal	Diagonal	Diagonal	Green	Green	Green	Green	Red	Red	Red
Bare bar* + mobile barrier support	first spring	Yellow	Yellow	Yellow	Yellow	Yellow	Green	Green	Green	Green	Red	Red	Diagonal
	second spring	Diagonal	Diagonal	Diagonal	Diagonal	Diagonal	Green	Green	Green	Green	Red	Red	Diagonal
Bare bar* + luminous cord	first spring	Yellow	Yellow	Yellow	Yellow	Yellow	Green	Green	Green	Green	Red	Red	Red
	second spring	Diagonal	Diagonal	Diagonal	Diagonal	Diagonal	Green	Green	Green	Green	Red	Red	Red
Bare bar* + luminous cord + mobile barrier support	first spring	Yellow	Yellow	Yellow	Yellow	Yellow	Green	Green	Green	Green	Red	Red	Diagonal
	second spring	Diagonal	Diagonal	Diagonal	Diagonal	Diagonal	Green	Green	Green	Green	Red	Red	Diagonal
Bare bar* + rack	first spring	Yellow	Yellow	Yellow	Yellow	Yellow	Green	Green	Green	Green	Red	Red	Red
	second spring	Diagonal	Diagonal	Diagonal	Diagonal	Diagonal	Green	Green	Green	Green	Red	Red	Red
Bare bar* + rack + luminous cord	first spring	Yellow	Yellow	Yellow	Yellow	Yellow	Green	Green	Green	Green	Red	Red	Red
	second spring	Diagonal	Diagonal	Diagonal	Diagonal	Diagonal	Green	Green	Green	Green	Red	Red	Red

* By Bare bar we mean a bar complete with the transparent slot cover and end plug.

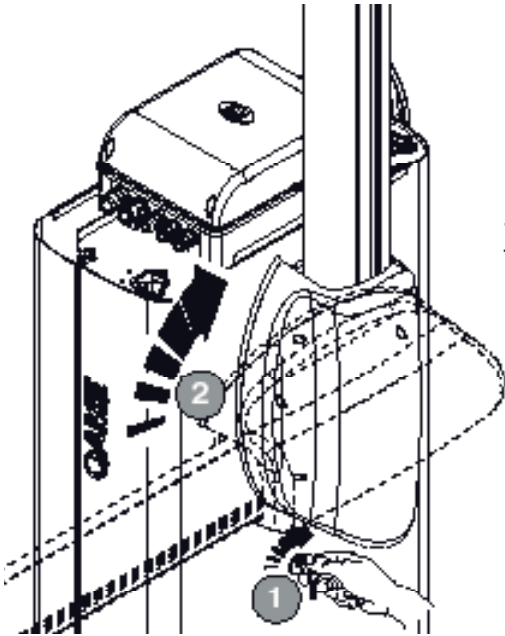

- Release the gearmotor and position the bar vertically, and then refasten the gearmotor.

- Insert the UNI5739 M12X70 screw into the spring securing bracket and tighten the UNI5588 M12 nut to the screw (1-2). Tighten the screw to spring (2) and the tie rod to the part underneath (3-4).

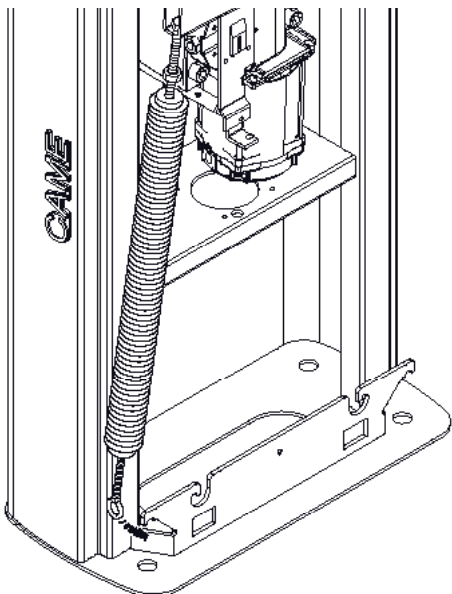
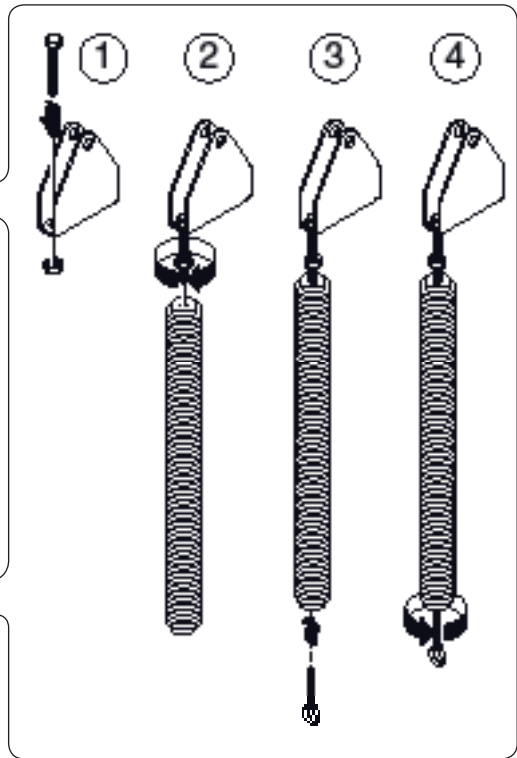
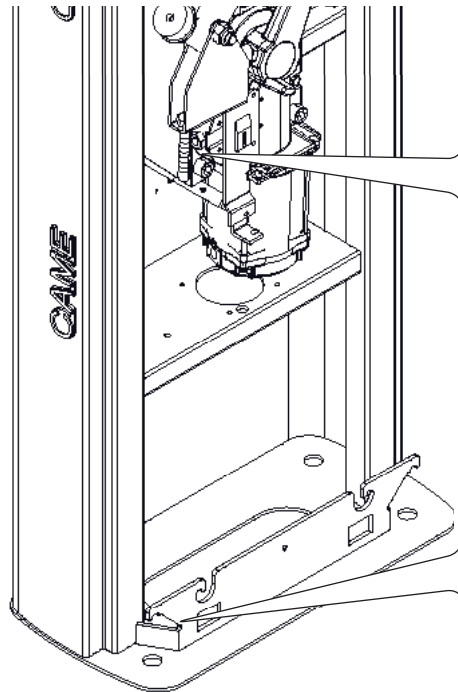

- Hook the tie rod to the anchoring ratchet. Perform the same procedure if there is a second screw.

- Release the gearmotor and manually turn the spring to increase or decrease traction until the bar rests at 45°.

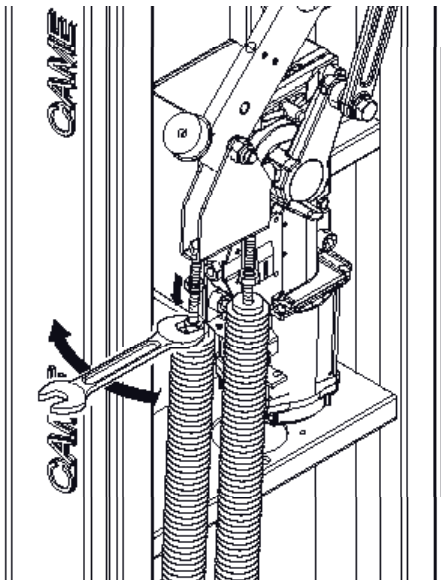
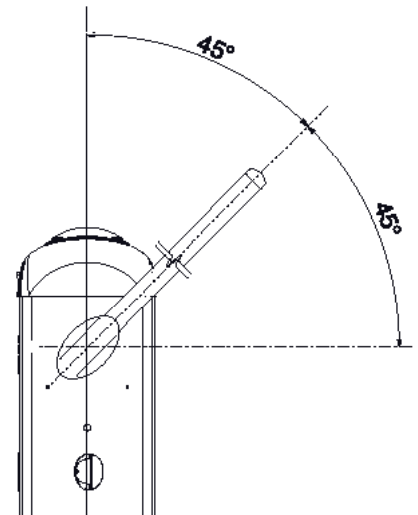
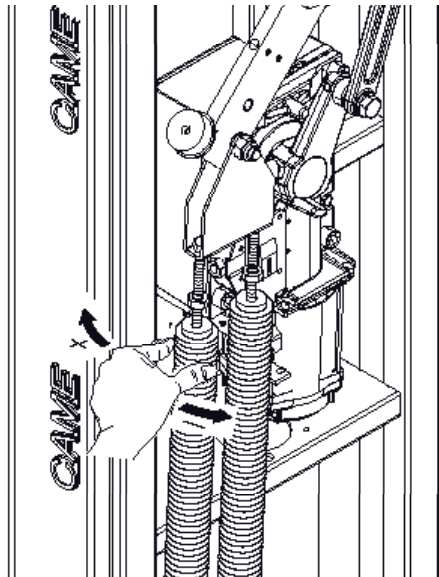

- Tighten the blocking nut and refasten the gearmotor.

Note: make sure the spring functions properly:

- the spring is loose when the bar is in the vertical position (at rest)
- the spring is tight when the bar is in the horizontal position (tense).

- Perform any electrical connections to the control panel (see *electrical connections* paragraph).

5.8 End stop adjustment

N.B.: perform this procedure after finishing the electrical connections.

Close the door and power up the system, activate the barrier to make sure it is parallel with the closed and at about 89° when open.

⚠ Warning! For greater safety and better unit performance, the bar's opening and closing operations should be carried out with the inspection hatch closed!

If any adjustment of the vertical position (= opening) is needed, open the inspection door and rotate the free damper clockwise (to increase the bar's run) or counter-clockwise (to decrease the run).

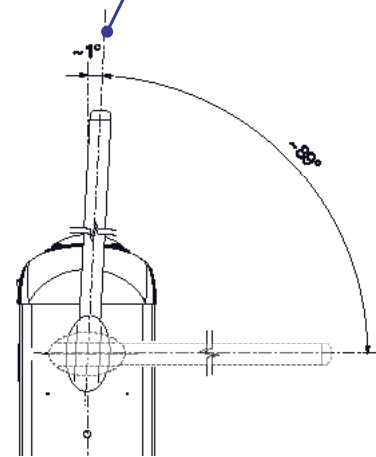
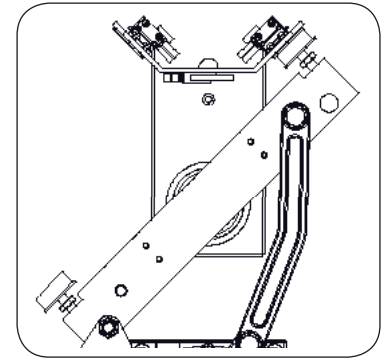
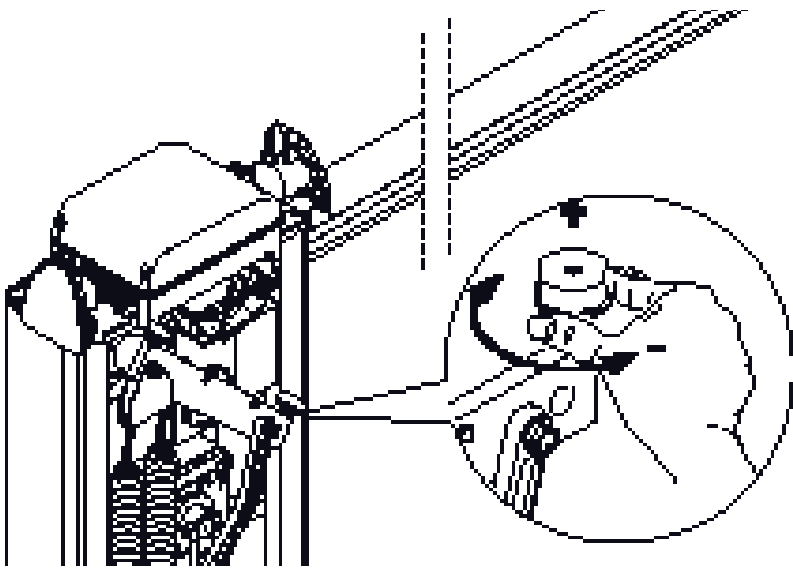

Similarly, open the bar and adjust the free damper, to regulate the horizontal position (= closing).

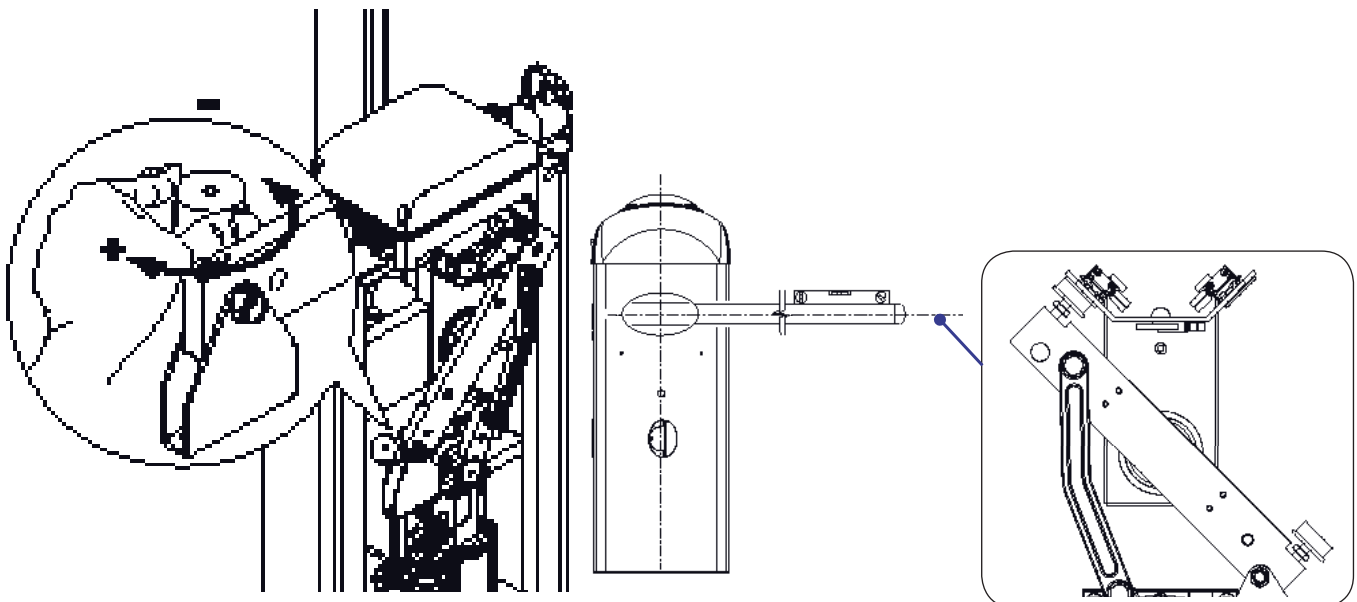

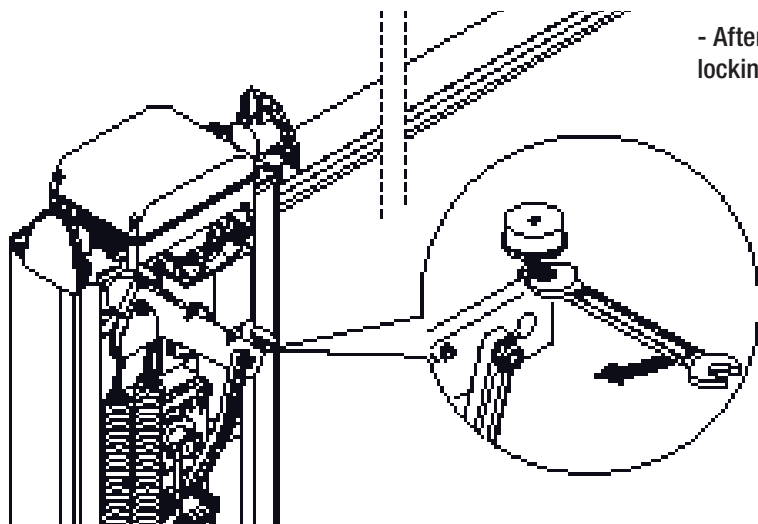

- After bar opening and closing adjustment, tighten the locking nuts under the dampers.

- After making adjustments and settings from the control panel, put the container lid in place and secure with screws....

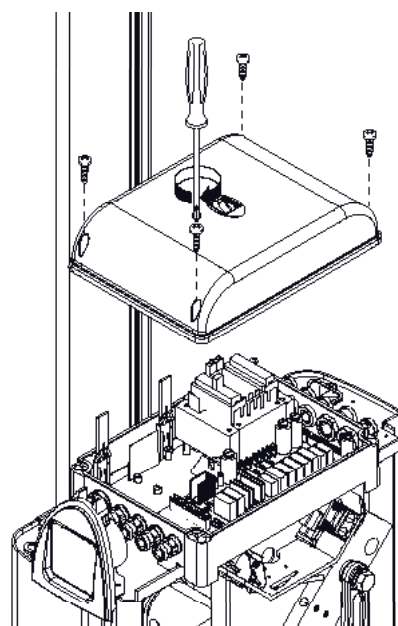

- ...place back the inspection door and the upper dome. Lock the door with the key.

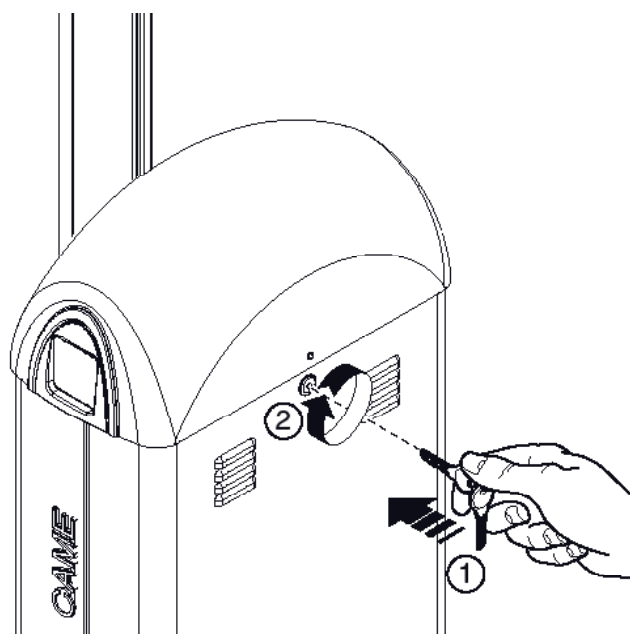
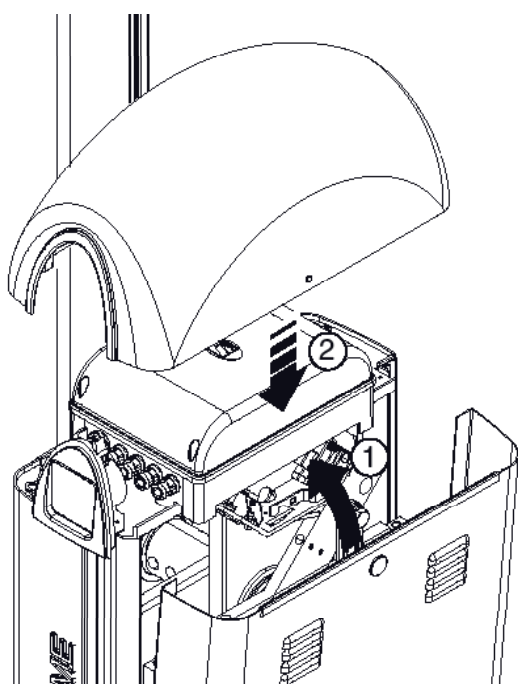

5.9 Manual release of the barrier

- Insert the key in the lock and turn it clock wise. Manually lift the bar and relock it by turning the key counterclockwise.



WARNING! The release procedure may constitute a hazard for the user when, for whatever reason – the bar is fixed improperly to the housing during assembly, or the bar is cracked or broken in an accident, and so on – the tension springs no longer provide balance! These can thus cause a brusque rotation of the bar attachment and/or of the bar itself.

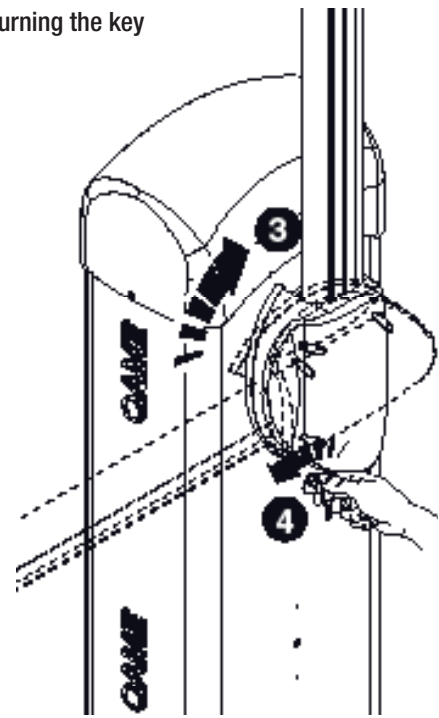
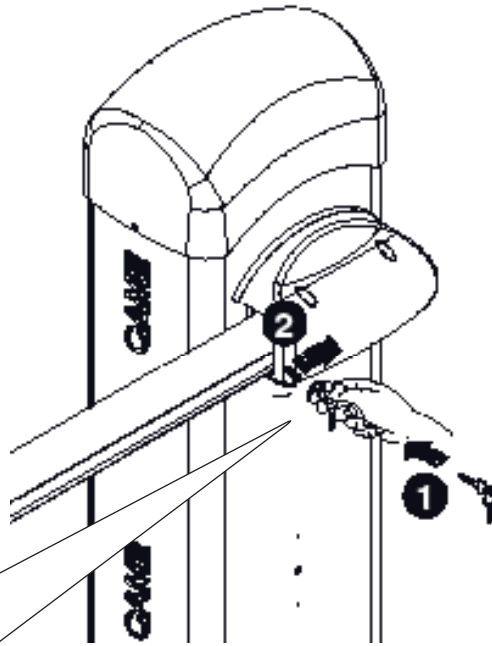

6 Description control panel

This product is engineered and manufactured by CAME cancelli automatici s.p.a. and complies with current safety regulations.

The control panel works on 230V a.c. of power, 50/60Hz frequency.

Both command and control devices and accessories are 24V powered. *Warning! Accessories must not exceed 40 W overall.*

In case the endpoint assembly does not intervene, the card nevertheless guarantees 20 seconds of operation. The card autonomously handles the Encoder (obstacle sensitive) safety function, which:

- when opening: the bar inverts the direction of travel until completely closed;
- when closing: the bar inverts the direction of travel until completely open.

Caution! after three consecutive direction reversals, the bar will remain up and automatic closure will be discontinued. To close the gate, use the radio remote control or the push-button.

All connections are protected by quick fuses, see table.

The card provides and controls the following functions:

- automatic closing after an open-command;
- immediate closure;
- pre-flashing by the motion indicator;
- obstacle detection when bar is still in any position.

The following command modes are possible:

- open/close;
- open/close and maintained action;
- Opening;
- Total stop.

Apposite trimmer regulate:

- the automatic closing run time;

Optional accessories:

- flashing crown and luminous band.
- bar open light marks the position of opening of the bar; it turns off after the closing operation;
- the RSE card, in order to activate the compass function or coupled through Dipswitches, see the relative technical literature.

Warning! Before acting on the machinery, cut off the main power supply and disconnect any emergency batteries.

TECHNICAL FEATURES	
Power supply	230 V - 50/60 Hz
max. rated power	400 W
Power draw when idling	25 W
Max power of 24V accessories	40 W
Insulation rating	II
Material	ABS
FUSES	
protection:	fuse type:
Electroblock	1.6 A-F
Electronic board (power supply line)	5 A-F
Accessories	2 A-F
Control devices	630 mA-F

6.1 Main components

- 1 - Line fuse
- 2 - Control unit fuse
- 3 - Accessories fuse
- 4 - Electrobloc fuse
- 5 - Powersource Terminals
- 6 - Transformer Terminals
- 7 - Electrobloc Terminals
- 8 - Endpoint assembly Terminals
- 9 - Coupled Barrier Terminals
- 10- Encoder Terminals
- 11- Connections Terminals
- 12- Radiofrequency Card input (see table on page 20)
- 13-RSE serial card input (optional for connection coupled barriers and/or compass)
- 14-TCA Trimmer: adjusts automatic closing time
- 15-Function selector Dip switch
- 16-Radio code storing buttons
- 17- Signalling LEDs for radio codes/automatic closing
- 18- Gate run counter
- 19- Motor Terminals
- 20- Transformer
- 21-Condenser

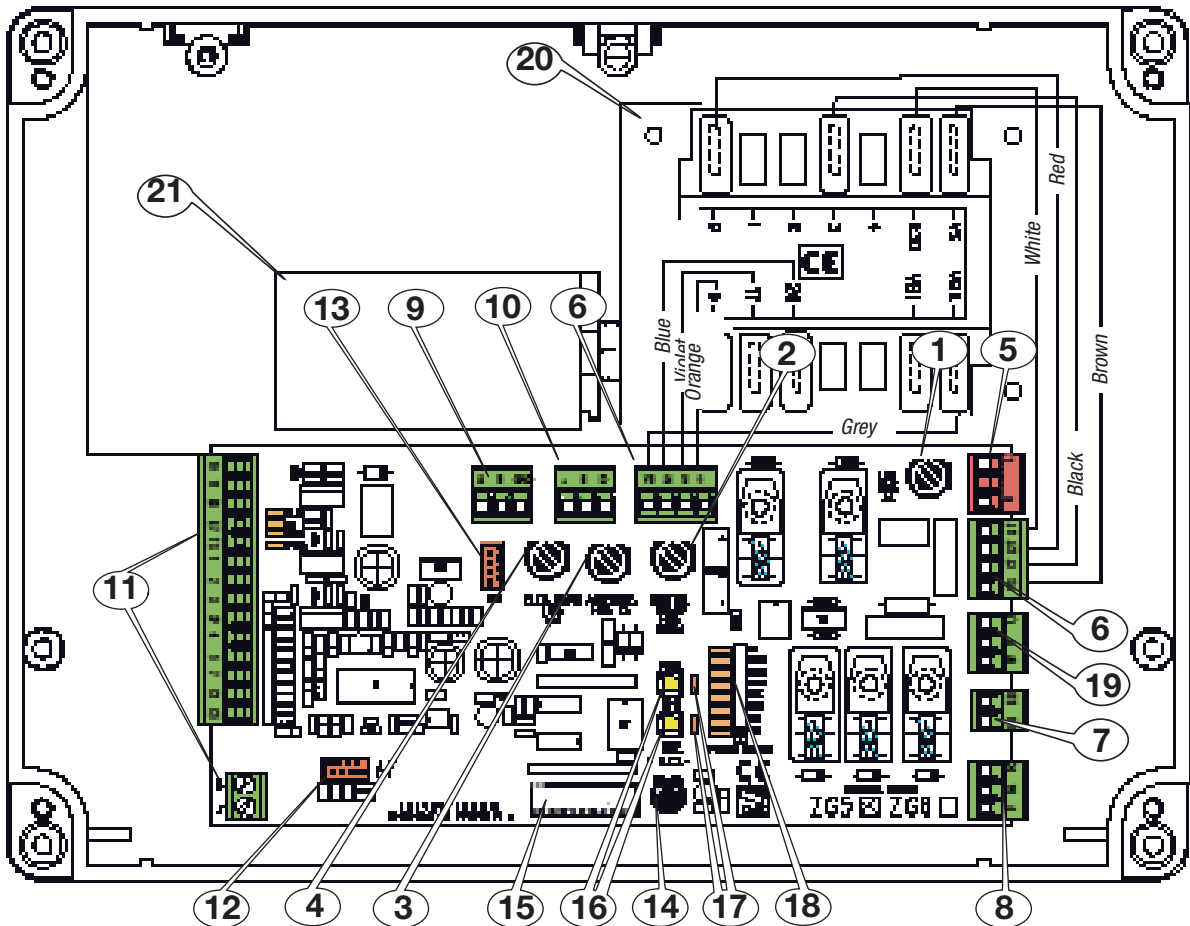

6.2 Electrical connections

Gearmotor, mechanical stops

Closing-microswitch

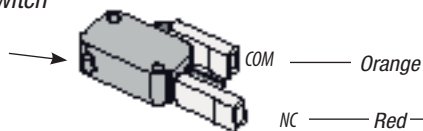

Opening-microswitch

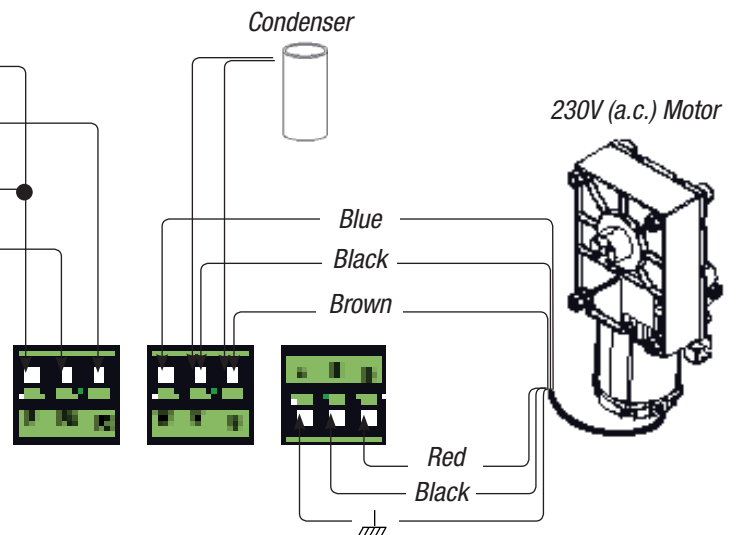
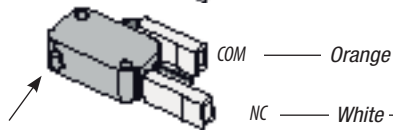

Description of required electrical connections. If installing on the right side, see page 7.

Power supply for accessories

ENGLISH

- VB2, 24V electro-
block powering (pre-
set connection)

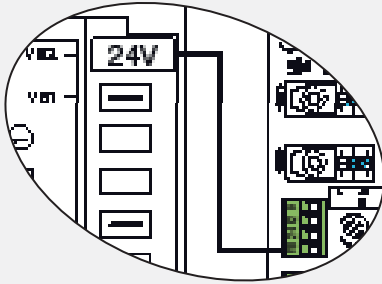

- VB1, 12V electro-
block powering

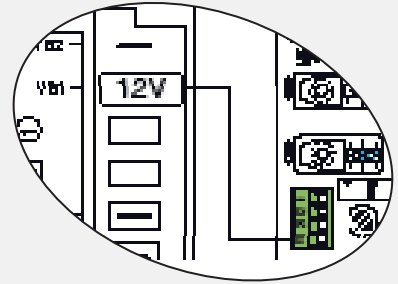

Power out socket for electroblock, activated with opening command.

Terminals for powering the following accessories:

- 24V A.C. normally;
 - 24V D.C. when the emergency batteries are working;
- Maximum allowed power: 40W

230V (a.c.) Power, 50/60Hz frequency

Cable lug with bolt and washer for
connecting to earth

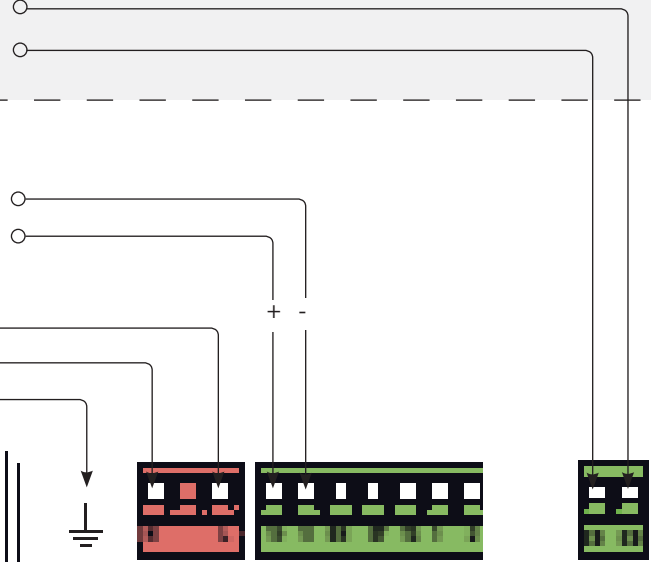
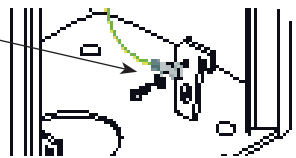

Warning devices

Open barrier warning light (contact rating: 24V – 3W max.)

– Signals when bar is in 'up' position, turns off once bar is down

Flashing Crown (Contact rating: 24V – 8W max.)

– Flashes when bar is opening and closing.

Luminous band (Contact rating: 24V-24W max.)

– Flashes when bar is closed or moving.

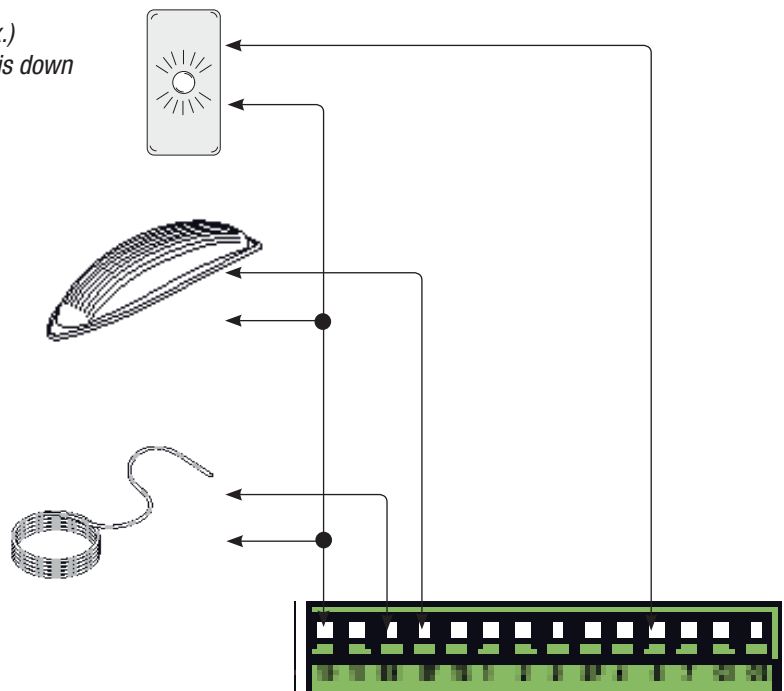

Command devices

Stop button (N.C. Contact) - Bar stop barrier.Excludes automatic closing.
For movement to resume, press the command button or transmitter button. If unused, set Dipswitch 6 to ON.

Opening button (N.O. contact) – Bar opening command.

Opening button (N.O. contact) - Opening command of the MASTER bar with coupled or compass connection.

Closing button (N.O. contact) - Bar closing command. Obligatory in case of “maintained action” function.

Command button (N.O. contact) - Bar opening and closing command. By pushing the button, the bar opens or inverts its movement depending on the selection made on Dipswitch 2.

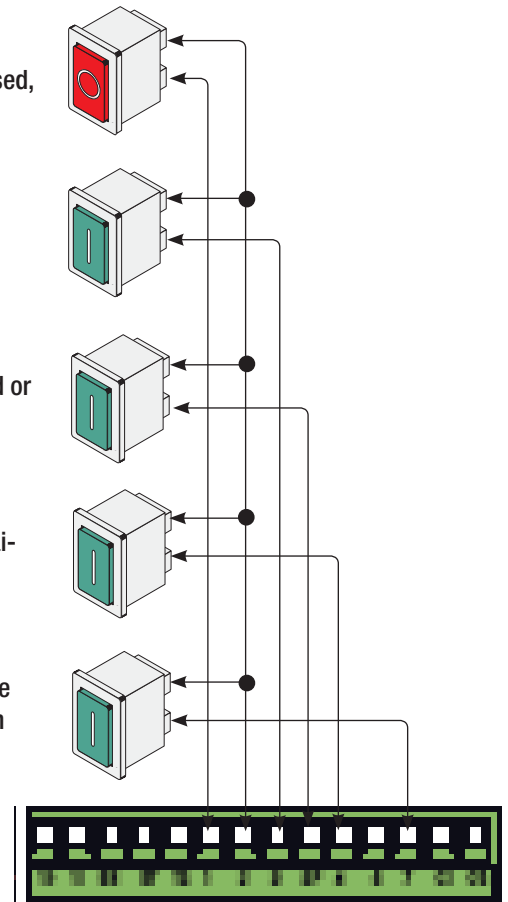

(N.O. contact) for “immediate closing”
- Automatic closing of the bar when obstacle passes in the detection range of the safety devices.

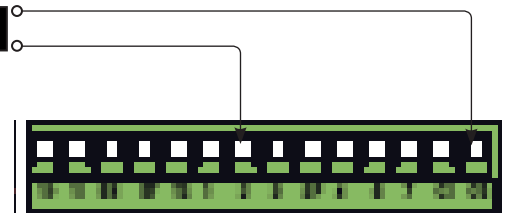

Safety devices

(N.C.) contact for «re-open during closing phase»
- input for safety devices such as photocells.

. If contact is opened, while bar is closing, the bar inverts its direction.

If unused, set DIP 7 switch to ON.

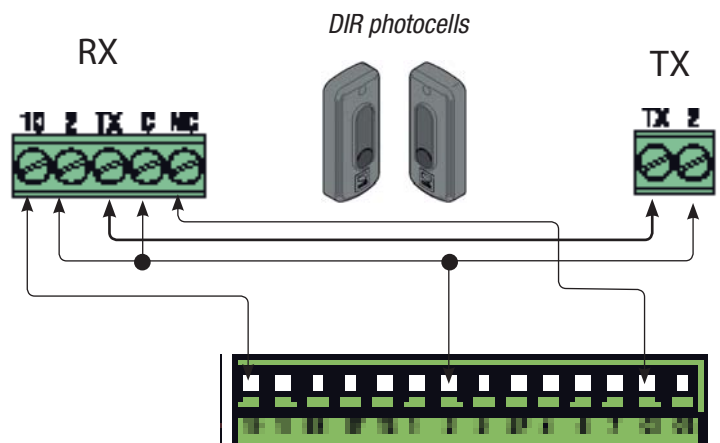

6.3 Electrical connection to operate the photocells' safety test

Allows the control assembly to check the efficiency of the safety devices (photoelectric cells) after each opening or closing command. A possible photoelectric cell malfunction is identified via LED indicator flashing on the control panel, consequently cancelling any remote control or pushbutton commands.

Electrical connection for safety test activation:

- photoelectric cell transmitters and receivers must be connected in the following way (see scheme)
- turn dip-switch 8 to ON to carry out the test.

IMPORTANT:

When carrying out the safety test function, contacts N.C. if not used, on the relative dip switches (see "functions selection" c. 6.9).

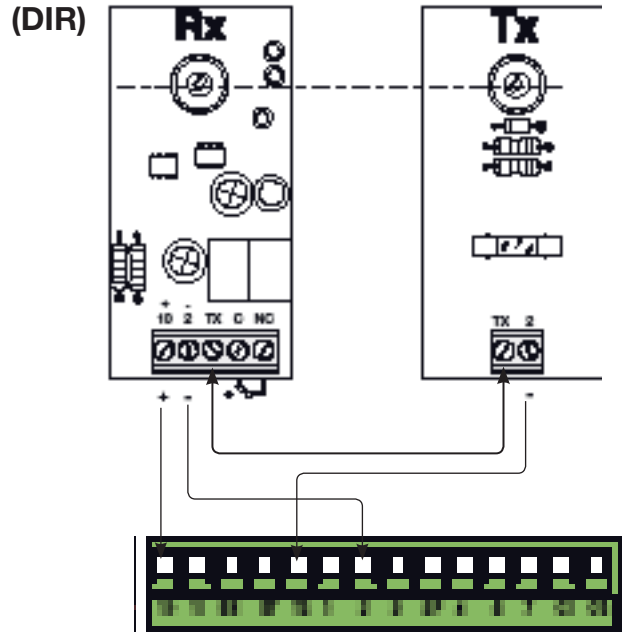

6.4 Motor torque limiter

To vary the motor torque, move the shown faston (the one with the black wire) to one of the 4 positions: 1 min – 4 max.

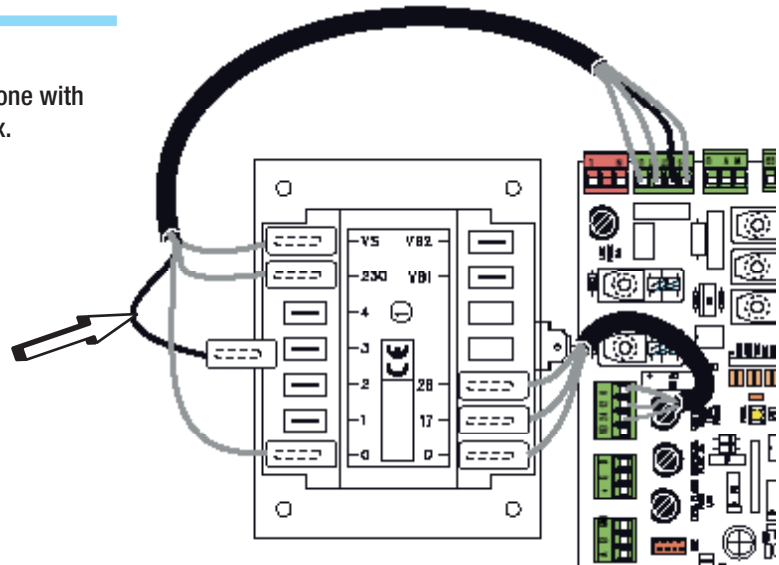

6.5 Managing operational surge

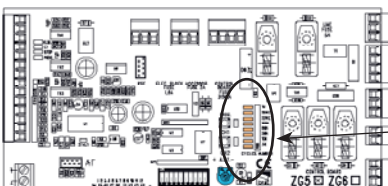

To manage the performance surge, position dip switches n. 1 and n. 3 to ON: all 8 led indicator lights on the performance counter light up.

Reset Dipswitch 3 to OFF and leave Dipswitch 1 in the ON mode, if you want to activate the automatic closing function.

6.6 Operation counter

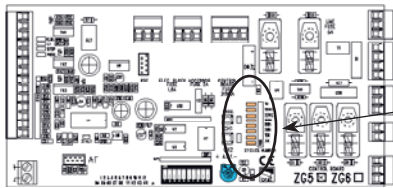

- Led n°1 = 5000 operation
- Led n°2 = 10000 operation
- Led n°3 = 25000 operation
- Led n°4 = 50000 operation
- Led n°5 = 100000 operation
- Led n°6 = 250000 operation
- Led n°7 = 500000 operation
- Led n°8 = 1000000 operation

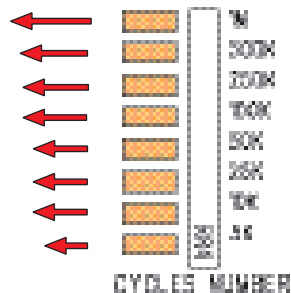

Visual count of the number of gate runs through the 8 LEDs, to zero-set the count, set Dipswitch 1 to OFF (if it is set to ON) and Dipswitch 3 to ON, press CH1 button and wait for all LEDs to turn off. Once zeroed out, reset Dipswitch 1 to ON (if selected) and Dipswitch to OFF.

6.7 Function selector

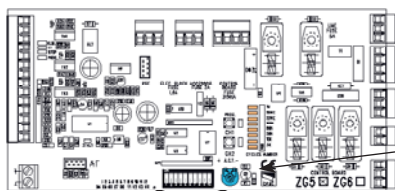

Default Setting



- 1 ON - Automatic Closing - The automatic closing timer activates at the end of the opening gate run. The pre-set time is adjustable, and is in any case conditioned by the activation of any safety devices, and does not activate after a total safety "stop" or during a blackout (1 OFF - deactivated);
- 2 OFF - "Open-close" function with [2-7] button and radio transmitter ((fitted with inserted radiofrequency card).
- 2 ON - "Open only" function with radio transmitter ((fitted with inserted radiofrequency card).
- 3 ON - Maintained Action – barrier works by keeping the button pressed, one button 2-3 for opening, and one 2-4 for closing (this excludes functioning of the radio transmitter).
- 4 ON - Pre-flashing while opening and closing – Following an opening or closing command, the flasher and/or luminous crown connected on [10-E7-/10-E6], flashes for 5 seconds before beginning its action.
- 5 ON - Obstacle detected - When motor is stopped (bar closed or after a total stop command) it prevents any movement if safety devices, such as photocells, detect any obstacles.
- 6 OFF - Total stop - This function stops the bar and consequently excludes any automatic closing cycle; to set in motion again, use either the keypad or transmitter. Insert the safety device in [1-2]; If unused, set DIP switch to ON.
- 7 OFF - Opening during closing - If the photocells detect an obstacle during bar is closing, gate motion is inverted until fully opened; connect the safety device to terminals [2-C1]; if unused, set DIP switch to ON;
- 8 ON - Functioning of the photocells' safety test - Allows the card to check the efficiency of any safety devices (i.e. photocells) after every opening or closing command; (8 OFF deactivated).
- 9 OFF - Encoder activated – to detect obstacles; (9 ON deactivated)
- 10 - If unused, set the DIP switch to OFF.

6.8 Settings

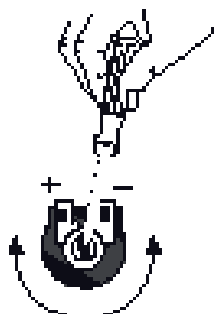
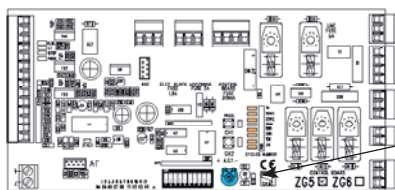

- «A.C.T.» Sets the waiting time while open. Once this time has elapsed, closing automatically takes place. The waiting time may be set from 1 to 120 seconds.

7 Activating the radio command

Antenna

Connect the antenna's RG58 cable to the opposite terminals.

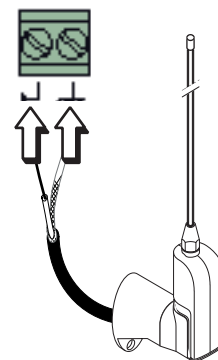

Radiofrequency card

Insert the radio frequency card into the electronic card **AFTER DISCONNECTING THE POWER** (and disconnecting any batteries).
N.B.: the electronic card picks up the radiofrequency card on when it is running on power.

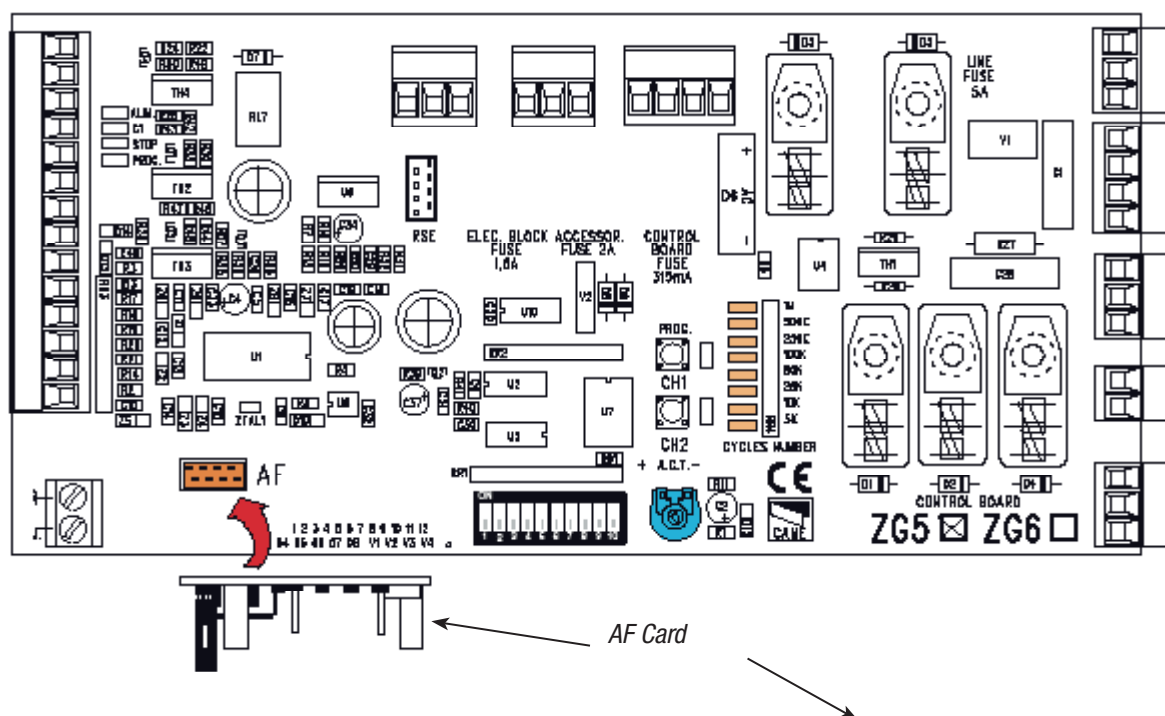

Frequency-MHz	radiofrequency card	Series of transmitters
FM 26.995	AF130	TFM
FM 30.900	AF150	TFM
AM 26.995	AF26	TOP
AM 30.900	AF30	TOP
AM 40.685	AF40	TOUCH
AM 433.92	AF43S / AF43SM	TAM / TOP
	AF43SR	ATOMO
	AF43S / AF43TW	TWIN
AM 868.35	AF868	TOP



ATOMO
AT01 • AT02
AT04

See instruction sheet in AF43SR radiofrequency card box

See attached instructions

TOUCH
TCH 4024 • TCH 4048

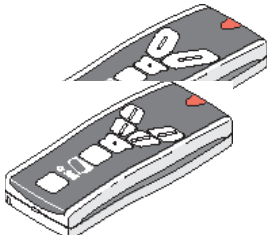

TOP
TOP-432A • TOP-434A

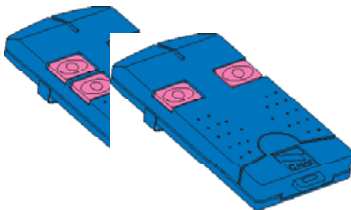

TOP
TOP-432NA • TOP-434NA
TOP-432S

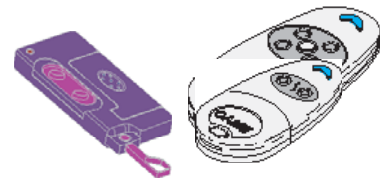

TOP
TOP-302A • TOP-304A

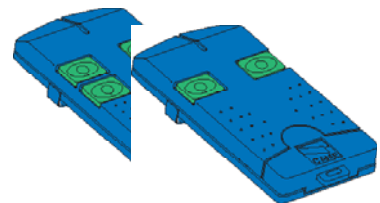

TAM
T432 • T434 • T438
TAM-432SA

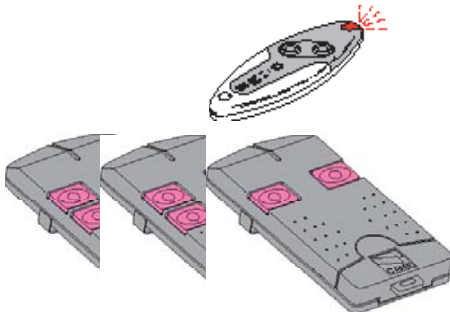

TFM
T132 • T134 • T138
T152 • T154 • T158

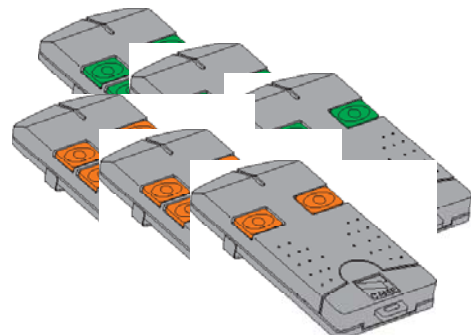

TWIN
TWIN2 • TWIN4

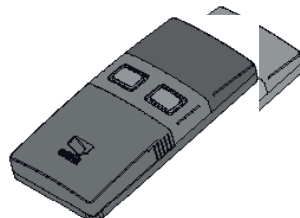

CH1 = Channel for direct command to a function of the the gearmotor's card, ("open only" / "open-close" command, depending on the choice made on DIP switch 2).

CH2 = Channel for direct commands with an accessory device (radio control with combined barrier connection or with bush).

- Keep the "CH1" button on the electronic card pressed. The LED flashes.

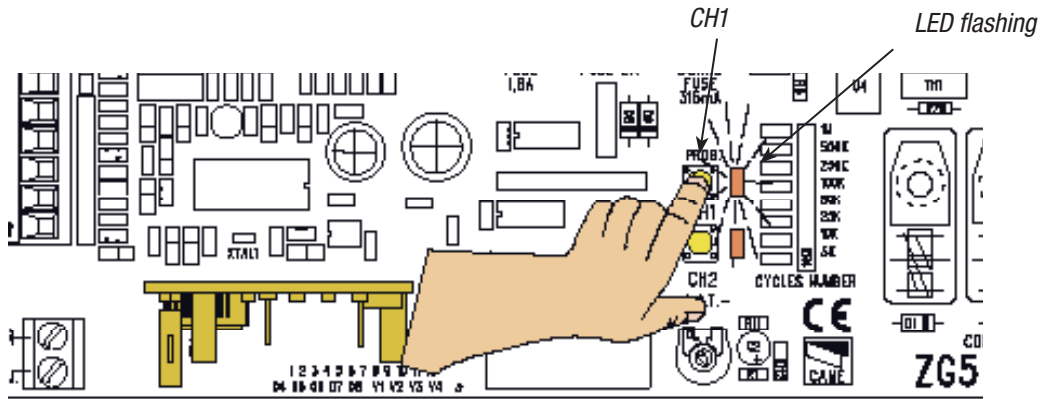

- Press the transmitter button you wish to memorise. The LED will stay on to show memorisation has been successful.

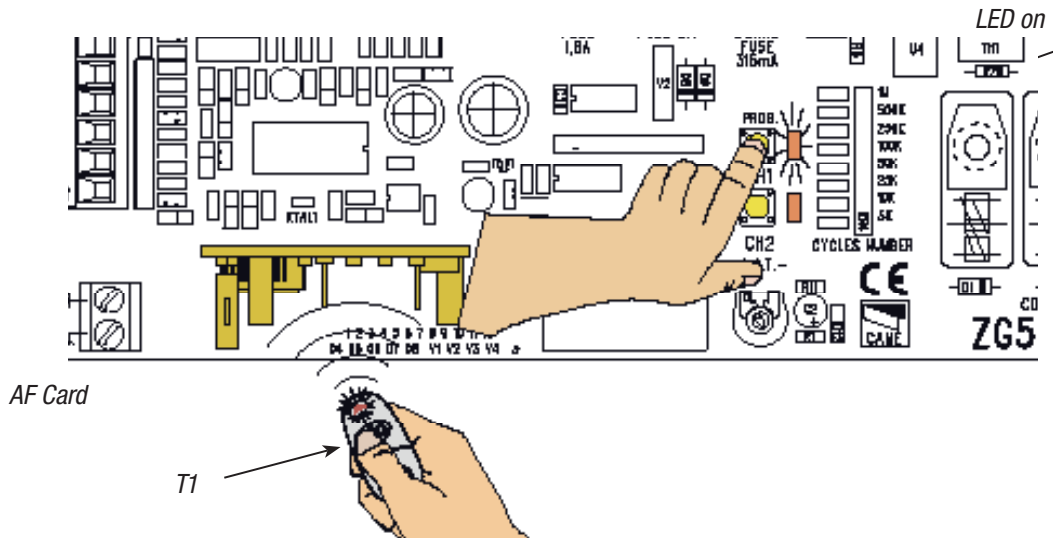

- Repeat the points 1 and 2 procedures for the "CH2" button associating this to another button on the transmitter.

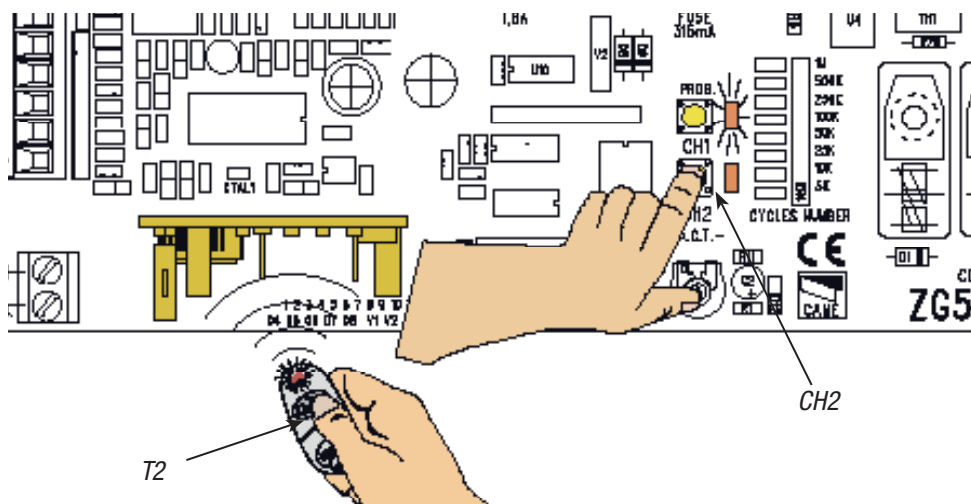

8 Safety instructions

Important safety instructions

This product must only be employed for its originally intended use. Any other use is wrong and potentially dangerous. The manufacturer cannot be held liable for any damages resulting from wrongful, erroneous or negligent uses. Avoid using near mechanical moving parts. Stay out of the opening/closing arc when operator is in motion. Do not exercise force against the motion of the operator as this could result in potentially dangerous situations.

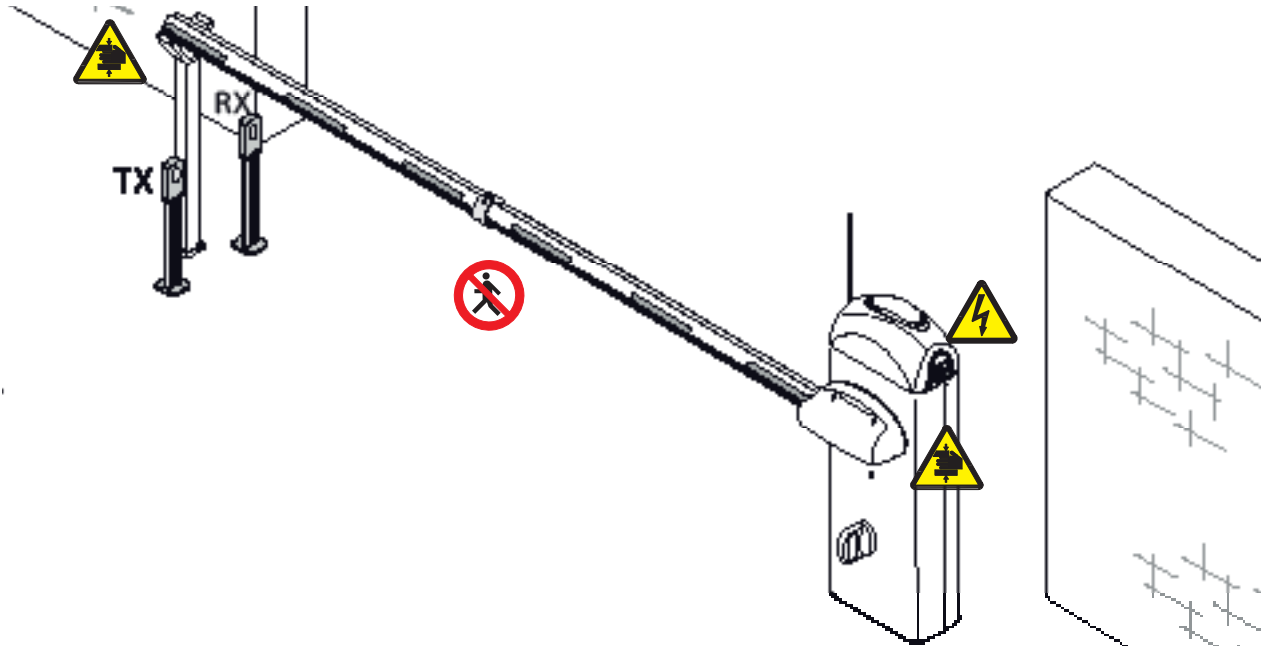

Do not allow children to play or loiter within the opening/closing arc of the operator. Keep remote controls and any other command device out the reach of children, to prevent operator from being activated by accident. In the event of anomalous behaviour, stop using the operator immediately.



Danger of crushing hands



Danger! High voltage



No transit during operation

9 Maintenance

9.1 Periodic maintenance

 Periodic maintenance to be carried out by the end-user is as follows: wipe clean the glass surface of the photocells; check that the safety devices work properly; remove any obstructions.

We suggest checking the state of lubrication and tightness of the anchoring screws on the operator.

-To check the efficiency of the safety devices, move an object in front of the photocells when gate is closing. If the operator inverts the motion or stops, the photocells are working properly.

This is the only maintenance procedure to be carried out with the power source connected.

-Before performing any maintenance procedures, cut off the main power, to prevent possible accidents due to gate movement.

-To clean the photocells use a water dampened cloth. Do not use solvents or other chemical products which may ruin the devices.

-In the event of any strange vibrations or squeaking, lubricate the joints with grease, as shown in the diagram.

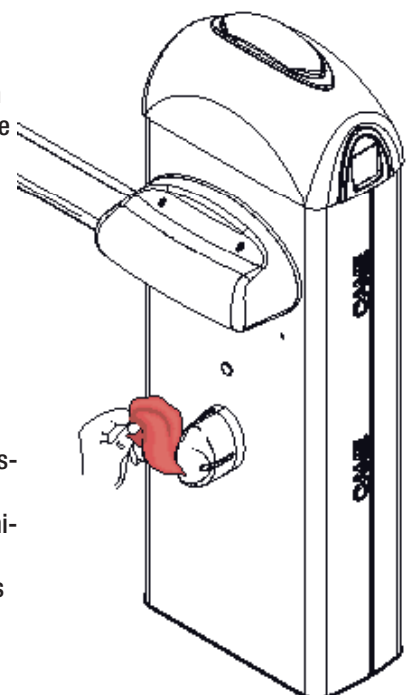

9.2 Extra-ordinary maintenance



The following table serves to note down any extraordinary maintenance, repairs or improvements performed by specialised firms.

N.B.: Any extraordinary maintenance must be performed by specialised technicians.

Extra-ordinary maintenancelog

Installer's stamp	Operator name
	Date of job
	Technician's signature
	Requester's signature
Job performed _____ _____ _____	

Installer's stamp	Operator name
	Date of job
	Technician's signature
	Requester's signature
Job performed _____ _____ _____	

Installer's stamp	Operator name
	Date of job
	Technician's signature
	Requester's signature
Job performed _____ _____ _____	

Installer's stamp	Operator name
	Date of job
	Technician's signature
	Requester's signature
Job performed _____ _____ _____	

Installer's stamp	Operator name
	Date of job
	Technician's signature
	Requester's signature
Job performed _____ _____ _____	

Installer's stamp	Operator name
	Date of job
	Technician's signature
	Requester's signature
Job performed _____ _____ _____	

9.3 Problem solving

MALFUNCTIONS	REFERENCES	CHECKS
The unit neither opens nor shuts	1-2-3-4-6-8-20	1 - Use key to lock trap door
The unit opens but does not close	4-7-10	2 - Disable “steady movement” with dipswitch
The unit shuts but does not open	4-7-9	3 – Check power supply and fuses
No automatic closure	11-12-13	4 - N.C. safety contacts open (1-2 / 2-C1)
The unit does not work if the remote control is used	2-14-16	6 - Disable master-slave function
The unit inverts direction	7	7 – Check spring tension and balancing
The unit works only with remote control	22	8 – Disable obstacle detection with dipswitch
The photoelectric cell does not react	12-23-24	9 – Check if end stop opens
The signalling LED indicator flashes rapidly	4	10 – Check if end stop closes
The signalling LED indicator remains on	13	11 - Activate “automatic closure” dip switch
The unit does not end its run	7	12 – Check the correct direction of movement
The bar is not properly balanced	7-15	13 - (2-3 / 2-4 / 2-7) command button
		14 -Check jumper on AF43S, turn on/off power
		15 – Check the bar length ratio with mountable accessories
		16 – Re-save radio code
		20 - Raise the motor torque
		22 - Enter or duplicate the same code in all the remote controls
		23 - Activate the photoelectric cell with the dipswitch
		24 - Connect the photoelectric cells in a series, not in parallel

10 Demolition and disposal

 In its premises, CAME CANCELLI AUTOMATICI S.p.A. implements an Environmental Management System certified in compliance with the UNI EN ISO 14standard to ensure environmental protection.

Please continue our efforts to protect the environment—which CAME considers one of the cardinal elements in the development of its operational and market strategies—simply by observing brief recommendations as regards disposal:

DISPOSAL OF PACKAGING

The packaging components (cardboard, plastic, etc.) are all classifiable as solid urban waste products and may be disposed of easily, keeping in mind recycling possibilities.

Prior to disposal, it is always advisable to check specific regulations in force in the place of installation.

PLEASE DISPOSE OF PROPERLY!

PRODUCT DISPOSAL

Our products are made up of various types of materials. Most of them (aluminium, plastics, iron, electrical wires, etc.) may be disposed of in normal garbage collection bins and can be recycled by disposing of in specific recyclable material collection bins and disposal in authorized centres. Other components (electrical boards, remote control batteries, etc.), however, may contain polluting substances. They should therefore be removed and given to qualified service companies for proper disposal.

Prior to disposal, it is always advisable to check specific regulations in force in the place of disposal.

PLEASE DISPOSE OF PROPERLY!



Came Cancelli Automatici s.p.a.

address Via Martiri della Libertà Street n. 15 postal code 31030
location Dosson di Casier province Treviso state Italia

DECLARES THAT THE PARTLY COMPLETED MACHINERY

AUTOMATIC ROAD BARRIERS

G2080Z; G2080IZ; G2081Z;
G4040Z; G4040IZ; G4041Z;
G2500; G2500N; G2510;
G3250; G3750; G3751;
G3000DX; G3000SX; G3000IDX; G3000ISX;
G4000C; G4000D; G4000E; G4000N; G4001; G4001E; G4010; G4011;
G6000; G6000B; G6000E; G6001; G6001E; G6010; G6011;
G6500; G6501;
G12000; G12000A; G12000B
G02040; G04060; G06080
G02801; G02803;
G03755DX; G03755SX

MEET THE APPLICABLE ESSENTIAL REQUIREMENTS

1.1.3 - 1.1.5 - 1.2.1 - 1.2.2 - 1.3.2 - 1.3.7 - 1.3.8.1 - 1.4.1 - 1.4.2 - 1.4.2.1 - 1.5.1 - 1.5.6 - 1.5.8 -
1.5.9 - 1.5.13 - 1.6.1 - 1.6.3 - 1.6.4 - 1.7.1 - 1.7.2 - 1.7.4

COMPLIES WITH THE PROVISIONS OF THE FOLLOWING DIRECTIVES

DIRECTIVE 2006/42/EC OF THE EUROPEAN PARLIAMENT AND OF THE COUNCIL
of 17 May 2006 on machinery, and amending Directive 95/16/EC.

DIRECTIVE 2004/108/EC OF THE EUROPEAN PARLIAMENT AND OF THE COUNCIL
of 15 December 2004 on the approximation of the laws of the Member States relating to electromagnetic compatibility.

PERSON AUTHORISED TO COMPILE THE RELEVANT TECHNICAL DOCUMENTATION

Came Cancelli Automatici s.p.a.

address Via Martiri della Libertà Street n. 15 postal code 31030
location Dosson di Casier province Treviso state Italia

The pertinent technical documentation has been drawn up in compliance with attached document IB

Came Cancelli Automatici S.p.A., following a duly motivated request from the national authorities, undertakes to provide information related to the quasi machines,

and FORBIDS

commissioning of the above mentioned until such moment when the final machine into which they must be incorporated, has been declared compliant, if pertinent, to 2006/42/CE.

Dosson di Casier (TV)
01 Feb 2011

Gianni Michielan
Managing Director

DDIB EN **G001** ver. 4.2 01 February 2011
Translation of the Declaration in the original language

Came Cancelli Automatici s.p.a.

Via Martiri della Libertà, 15 - 31030 Dosson di Casier - Treviso - Italy - Tel. (+39) 0422 4940 - Fax (+39) 0422 4941
info@came.it - www.came.com

Cap. Soc. 1.610.000,00 € - C.F. e P.I. 03481280265 - VAT IT 03481280265 - REA TV 275359 - Reg Imp. TV 03481280265

CAMEGROUP
INDUSTRIE ELETTRICHE



CAME.COM

CAME S.P.A.

Via Martiri Della Libertà, 15
31030 Dosson di Casier - Treviso - Italy
tel. (+39) 0422 4940 - fax. (+39) 0422 4941