



Automatic road barriers

FA01625-EN



**G6000
G6000X**

**G6001
G6000Y
G6010X**

**G6001-316
G6010**

INSTALLATION MANUAL

EN

English



MANUAL RELEASE

⚠ Releasing the device may be dangerous for the user, if the boom fastening has been damaged or if the boom is no longer intact, as the result of an accident or installation error.

In these cases, the tensioned springs no longer guarantee that the boom is balanced. The boom may suddenly rotate when being released.

⚠ Manual release may cause the operator to move in an uncontrolled manner due to a mechanical fault or an imbalance.

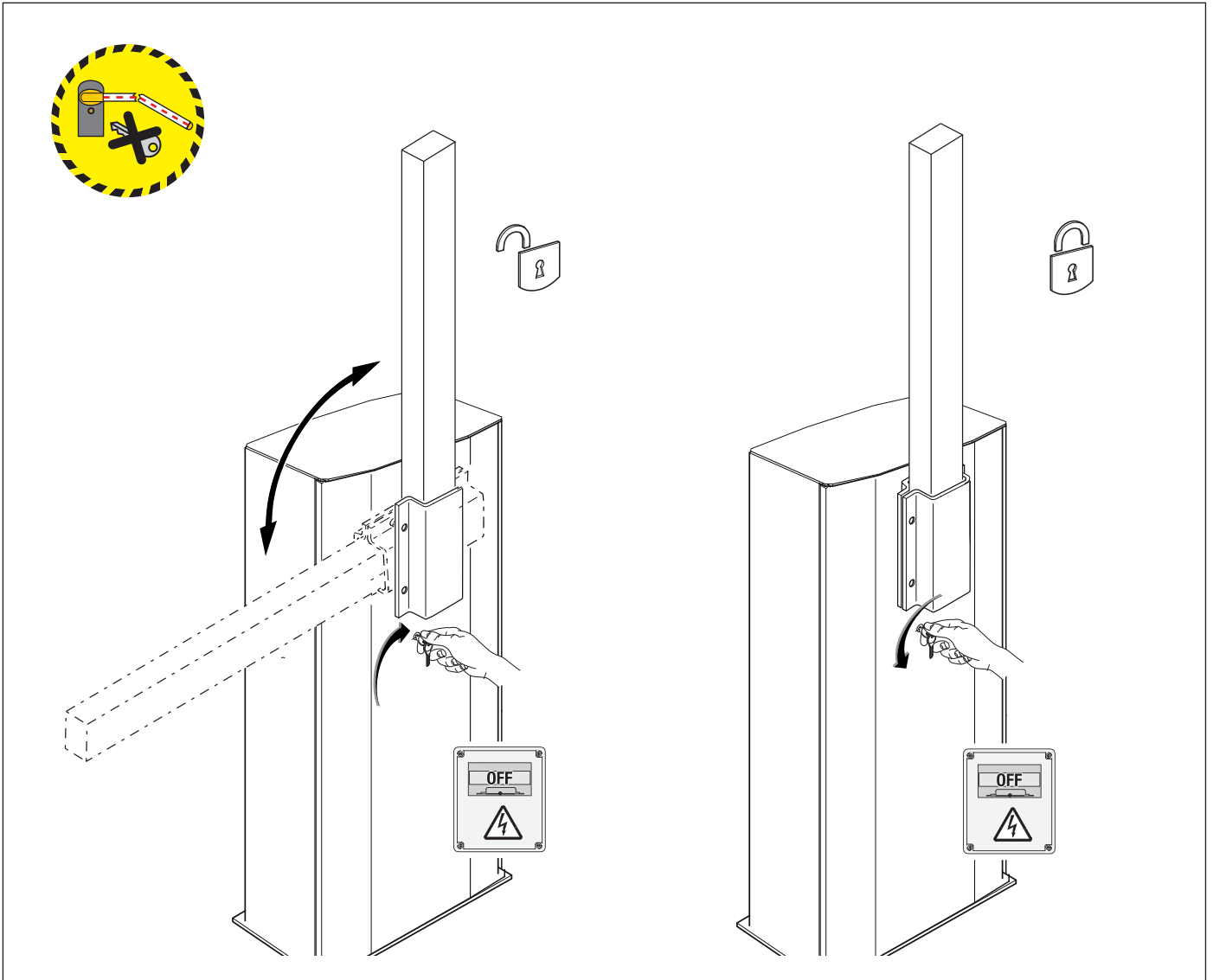

⚠ Important safety instructions.

⚠ Please follow all of these instructions. Improper installation may cause serious bodily harm.

⚠ Before continuing, please also read the general precautions for users.

Only use this product for its intended purpose. Any other use is hazardous.

- The manufacturer cannot be held liable for any damage caused by improper, unreasonable or erroneous use.
- This product is defined by the Machinery Directive (2006/42/EC) as partly completed machinery.
- Partly completed machinery means an assembly which is almost machinery but which cannot in itself perform a specific application.
- Partly completed machinery is only intended to be incorporated into or assembled with other machinery or other partly completed machinery or equipment thereby forming machinery to which the Machinery Directive (2006/42/EC) applies.
- The final installation must comply with the Machinery Directive (2006/42/EC) and the European reference standards in force.
- The manufacturer declines any liability for using non-original products, which would also void the warranty.
- All operations indicated in this manual must be carried out exclusively by skilled and qualified personnel and in full compliance with the regulations in force.
- The device must be installed, wired, connected and tested according to good professional practice, in compliance with the standards and laws in force.
- Make sure the mains power supply is disconnected during all installation procedures.
- Check that the temperature ranges given are suitable for the installation site.
- Make sure that opening the automatic barrier does not constitute a hazard.
- Do not install on slopes i.e. any surfaces that are not perfectly level.
- Do not install the operator on surfaces that could yield and bend. If necessary, add suitable reinforcements to the anchoring points.
- Make sure that no direct jets of water can wet the product at the installation site (sprinklers, water cleaners, etc.).
- Make sure you have set up a suitable dual-pole cut-off device along the power supply that is compliant with the installation rules. It should completely cut off the power supply according to category III surcharge conditions.
- Demarcate the entire site properly to prevent unauthorised personnel from entering, especially minors.
- In case of manual handling, have one person for every 20 kg that needs hoisting; for non-manual handling, use proper hoisting equipment in safe conditions.
- When the operator is being fixed in place, it may be unstable and overturn. Be careful and do not lean on it until it is fully fastened in place.
- Use suitable protection to prevent any mechanical hazards due to persons loitering within the operating range of the operator.
- The electrical cables must pass through special pipes, ducts and cable glands in order to guarantee adequate protection against mechanical damage.
- Make sure that the moving mechanical parts are suitably far away from the wiring.
- The electrical cables must not touch any parts that may overheat during use (such as the motor and transformer).
- All fixed controls must be clearly visible after installation, in a position that allows the guided part to be directly visible, but far away from moving parts. In the case of a hold-to-run control, this must be installed at a minimum height of 1.5 m from the ground and must not be accessible to the public.
- If the passage is wider than 3 m, you must use a fixed support for the boom.
- If not already present, apply a permanent tag that describes how to use the manual release mechanism close to it.
- Make sure that the operator has been properly adjusted and that the safety and protection devices and the manual release are working properly.
- Before handing over to the final user, check that the system complies with the harmonised standards and the essential requirements of the Machinery Directive (2006/42/EC).
- Any residual risks must be indicated clearly with proper signage affixed in visible areas, and explained to end users.
- Put the machine's ID plate in a visible place when the installation is complete.
- If the power supply cable is damaged, it must be immediately replaced by the manufacturer or by an authorised technical assistance centre, or in any case, by qualified staff, to prevent any risk.
- Keep this manual inside the technical folder along with the manuals of all the other devices used for your automation system.
- Make sure to hand over to the end user all the operating manuals of the products that make up the final machinery.
- The product, in its original packaging supplied by the manufacturer, must only be transported in a closed environment (railway carriage, containers, closed vehicles).
- If the product malfunctions, stop using it and contact customer services at <https://www.came.com/global/en/contact-us> or via the telephone number on the website.
- The manufacture date is provided in the production batch printed on the product label. If necessary, contact us at <https://www.came.com/global/en/contact-us>.
- The general conditions of sale are given in the official CAME price lists.

Main points of danger for people

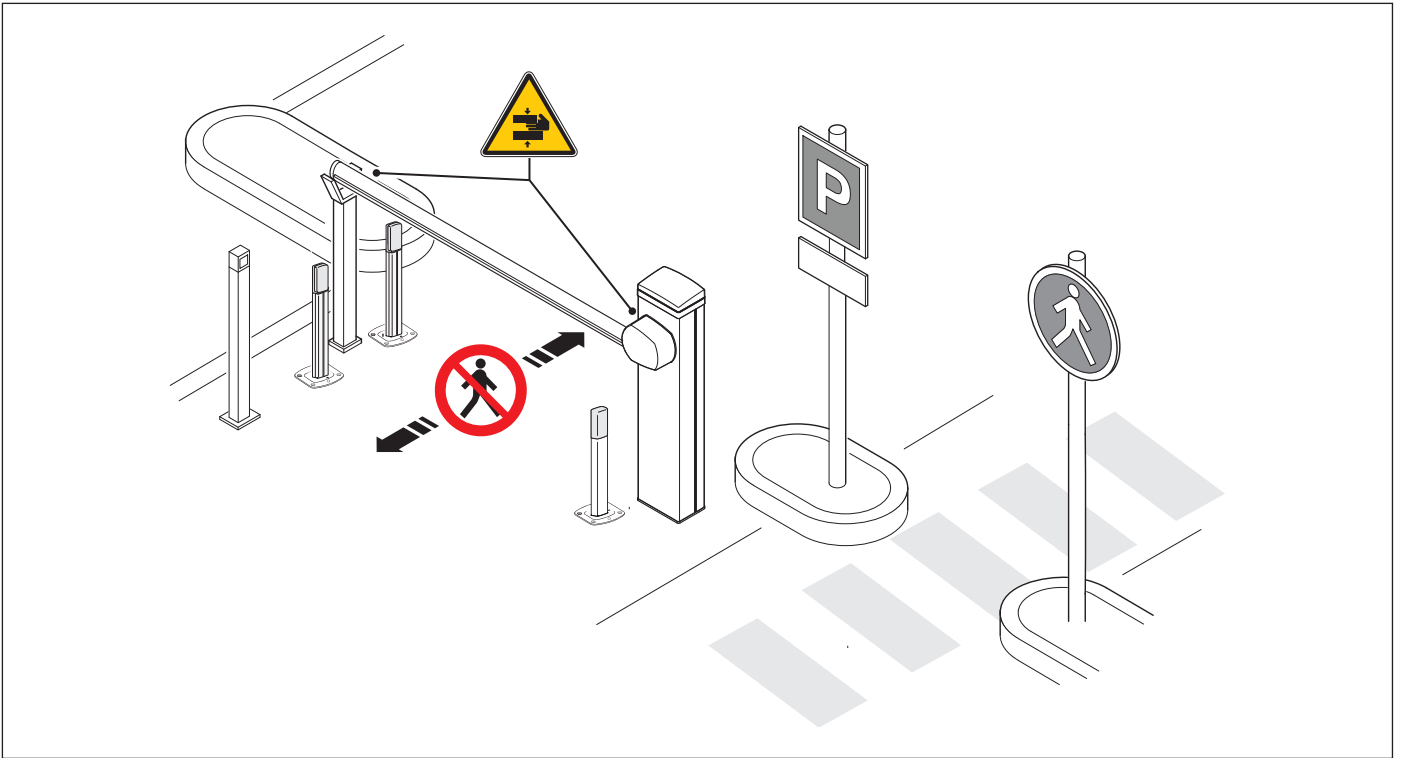

 Risk of trapping hands.

 No transiting.

DISMANTLING AND DISPOSAL

 CAME S.p.A. employs an Environmental Management System at its premises. This system is certified and compliant with the UNI EN ISO 14001 standard to ensure that the environment is respected and safeguarded. Please continue safeguarding the environment. At CAME we consider it one of the fundamentals of our operating and market strategies. Simply follow these brief disposal guidelines:

DISPOSING OF THE PACKAGING

The packaging materials (cardboard, plastic, etc.) can be disposed of easily as solid urban waste, separated for recycling.

Before dismantling and disposing of the product, please always check the local laws in force.

DISPOSE OF THE PRODUCT RESPONSIBLY.

DISPOSING OF THE PRODUCT

Our products are made of various materials. Most of these materials (aluminium, plastic, iron and electrical cables) are classified as solid urban waste. They can be separated for recycling and disposed of at authorised waste treatment plants.

Other components (electronic boards, transmitter batteries, etc.) may contain pollutants.



These must be removed and disposed of by an authorised waste disposal and recycling firm.

It is always advisable to check the specific laws that apply in your area.

DISPOSE OF THE PRODUCT RESPONSIBLY.

PRODUCT DATA AND INFORMATION

Key

-  This symbol shows which parts to read carefully.
 This symbol shows which parts describe safety issues.
 This symbol shows what to tell users.

The measurements, unless otherwise stated, are in millimetres.

Description

001G6000

Barrier made of painted galvanized steel designed to fit accessories.

001G6001

Barrier made of AISI 304 satin-finish steel, designed to fit accessories.

001G6001-316

Barrier made of AISI 316 satin-finish steel, designed to fit accessories.

001G6000X

Barrier made of galvanized steel with customised RAL paint designed to fit accessories.

001G600Y

Barrier made of RAL 1023 painted galvanized steel designed to fit accessories.

001G6010

Barrier made of painted galvanized steel set up to fit accessories. The barrier includes balance springs (2 x 001G04060).

001G6010X

Barrier made of galvanized steel with customised RAL paint designed to fit accessories.

Intended use

Ideal solution for apartment blocks and industrial use.

 Any installation and/or use other than that specified in this manual is forbidden.

Usage limitations

MODELS	G6000	G6001	G6001-316	G6000X	G6000Y	G6010	G6010X
Max. net clearance width (m)	6,5	6,5	6,5	6,5	6,5	6,5	6,5

Technical data

MODELS	G6000	G6001	G6001-316	G6000X	G6000Y	G6010	G6010X
Power supply (V - 50/60 Hz)	230 AC	230 AC	230 AC	230 AC	230 AC	120 AC	120 AC
Motor power supply (V)	24 DC	24 DC	24 DC	24 DC	24 DC	24 DC	24 DC
Power (W)	300	300	300	300	300	300	300
Current draw (A)	15 Max.	15 Max.	15 Max.	15 Max.	15 Max.	15 Max.	15 Max.
Colour	2004	-	-	RAL X	1023	2004	RAL X
Operating temperature (°C)	-20 ÷ +55	-20 ÷ +55	-20 ÷ +55	-20 ÷ +55	-20 ÷ +55	-20 ÷ +55	-20 ÷ +55
Storage temperature (°C)*	-25 ÷ +45	-25 ÷ +45	-25 ÷ +45	-25 ÷ +45	-25 ÷ +45	-25 ÷ +45	-25 ÷ +45
Torque (Nm)	600	600	600	600	600	600	600
Opening time at 90° (s)	4 ÷ 8	4 ÷ 8	4 ÷ 8	4 ÷ 8	4 ÷ 8	4 ÷ 8	4 ÷ 8
Duty cycle (%)	HEAVY-DUTY SERVICE	HEAVY-DUTY SERVICE	HEAVY-DUTY SERVICE	HEAVY-DUTY SERVICE	HEAVY-DUTY SERVICE	HEAVY-DUTY SERVICE	HEAVY-DUTY SERVICE
Protection rating (IP)	54	54	54	54	54	54	54
Insulation class	I	I	I	I	I	I	I
Average life (cycles)**	1.000.000	1.000.000	1.000.000	1.000.000	1.000.000	1.000.000	1.000.000

(*) Before installing the product, keep it at room temperature where it has previously been stored or transported at a very high or very low temperature.

(**) The average product life specified should be understood purely as an indicative estimate. It applies to normal usage conditions and where the product has been installed and maintained in compliance with the instructions provided in the CAME technical manual. The average product life is also affected, including significantly, by other variables such as, but not limited to, climatic and environmental conditions. The average product life should not be confused with the product warranty.

Fuse table

MODELS	G6000	G6001	G6001-316	G6000X	G6000Y	G6010	G6010X
Line fuse	1.6 A-F	1.6 A-F	1.6 A-F	1.6 A-F	1.6 A-F	3.15 A-F	3.15 A-F
Accessory fuse	2 A-F	2 A-F	2 A-F	2 A-F	2 A-F	2 A-F	2 A-F
Control board fuse	1 A-F	1 A-F	1 A-F	1 A-F	1 A-F	1 A-F	1 A-F

Description of parts

Barrier

- ❶ Boom attachment
- ❷ Boom anchoring plate
- ❸ Lock for release
- ❹ Cabinet
- ❺ Inspection hatch
- ❻ Microswitch support plate

- ❼ Mechanical stops
- ❽ Balance springs
- ❾ Control panel
- ❿ Anchoring plate
- ⓫ Anchoring brackets

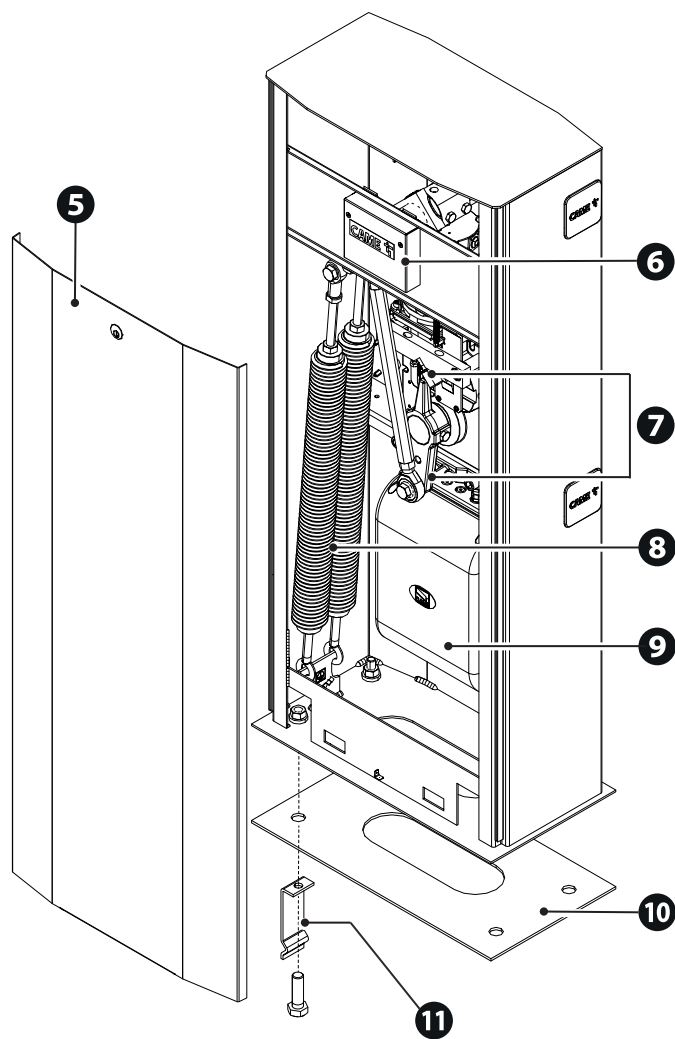
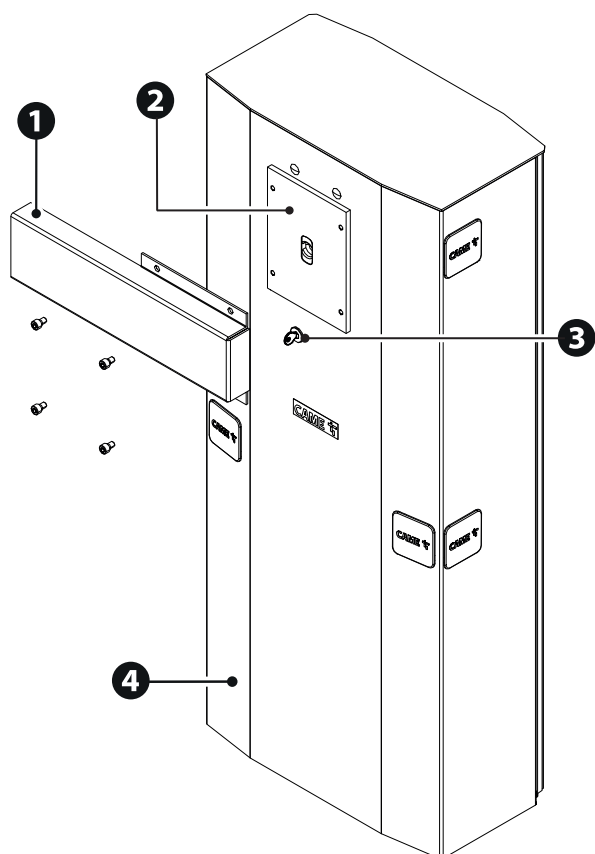

Control board ZL39B

- ❶ Terminal board for connecting control and safety devices
- ❷ Terminal board associated with the RSE connector for paired, alternate or CRP connection
- ❸ Terminal board for connecting the keypad selector
- ❹ Terminal board for connecting the transponder selector switch
- ❺ Display
- ❻ Accessories fuse
- ❼ Control board fuse
- ❽ Terminal board for connecting the transformer
- ❾ Terminal board for connecting the transformer thermal cut-off switch
- ❿ Terminal board for limit-switch micro-switches
- ⓫ Terminal board for connecting the antenna
- ⓬ Connector for plug-in radio frequency card (AF)
- ⓭ RSE card connector
- ⓮ Connector for the R700 or R800 decoding card
- ⓯ Programming buttons
- ⓰ Memory Roll card connector
- ⓱ Programming status warning LED
- ⓲ Power LED
- ⓳ Terminal board for motor power supply

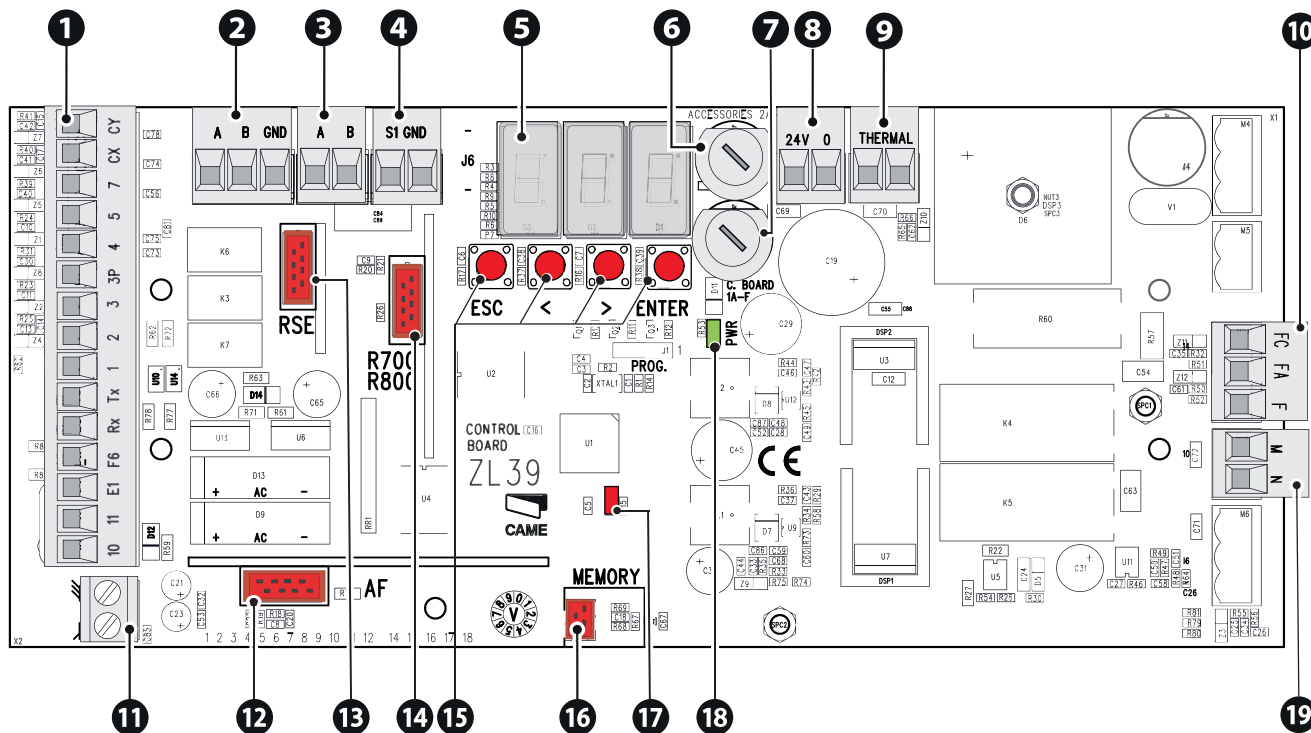

Size

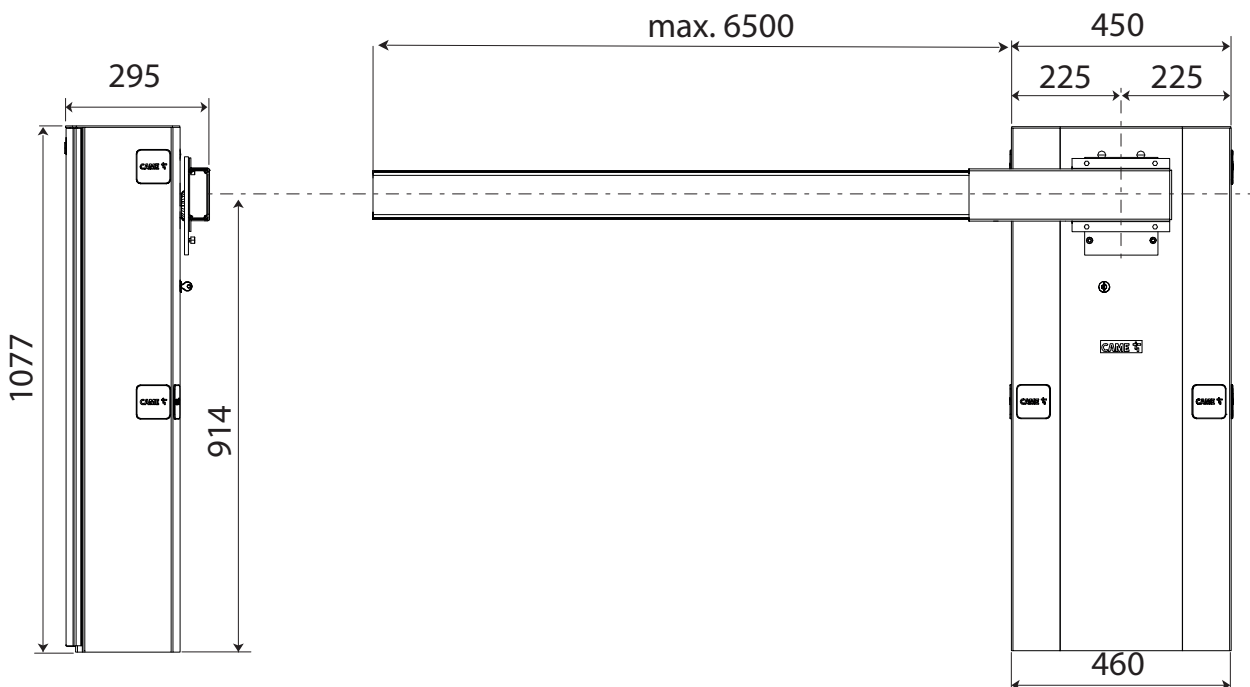

Cable types and minimum thicknesses

Cable length (m)	up to 20	from 20 to 30
Power supply 230 V AC	3G x 1.5 mm ²	3G x 2.5 mm ²
Power supply 120 V AC	3G x 1.5 mm ²	3G x 2.5 mm ²
24 V AC/DC flashing beacon	2 x 1 mm ²	2 x 1 mm ²
TX Photocells	2 x 0.5 mm ²	2 x 0.5 mm ²
RX photocells	4 x 0.5 mm ²	4 x 0.5 mm ²
Command and control devices	*no. x 0.5 mm ²	*no. x 0.5 mm ²

* no. = see product assembly instructions - Warning: the cable cross-section is indicative and varies according to the motor power and cable length.

 To connect the antenna, use RG58 cable (up to 5 m).

 For installation in an outdoor environment, use cables with properties at least equivalent to those of type H05RN-F (with designation 60245 IEC 57).

 For installation in an indoor environment, use cables with properties at least equivalent to those of type H05VV-F (designation to 60227 IEC 53).

 If the cable lengths differ from those specified in the table, define the cable cross-sections according to the actual power draw of the connected devices and in line with regulation CEI EN 60204-1.

 For multiple, sequential loads along the same line, recalculate the values in the table according to the actual power draw and distances. For information on connecting products not covered in this manual, please see the documentation accompanying the products themselves.

 For paired and CRP connection, use a UTP CAT5 cable. Maximum length 1000 metres.

INSTALLATION

 The following illustrations are examples only. The space available for fitting the operator and accessories varies depending on the area where it is installed. It is up to the installer to find the most suitable solution.

In case of manual handling, have one person for every 20 kg that needs hoisting; for non-manual handling, use proper hoisting equipment in safe conditions. When the operator is being fixed in place, it may be unstable and overturn. Be careful and do not lean on it until it is fully fastened in place.

Preliminary operations

 If the flooring does not allow the device to be fastened in a solid and stable way, lay a cement slab.

Dig a hole for the foundation frame.

Set up the corrugated tubes needed for the wiring coming out of the junction pit.

 The number of tubes depends on the type of system and the accessories that are going to be fitted.

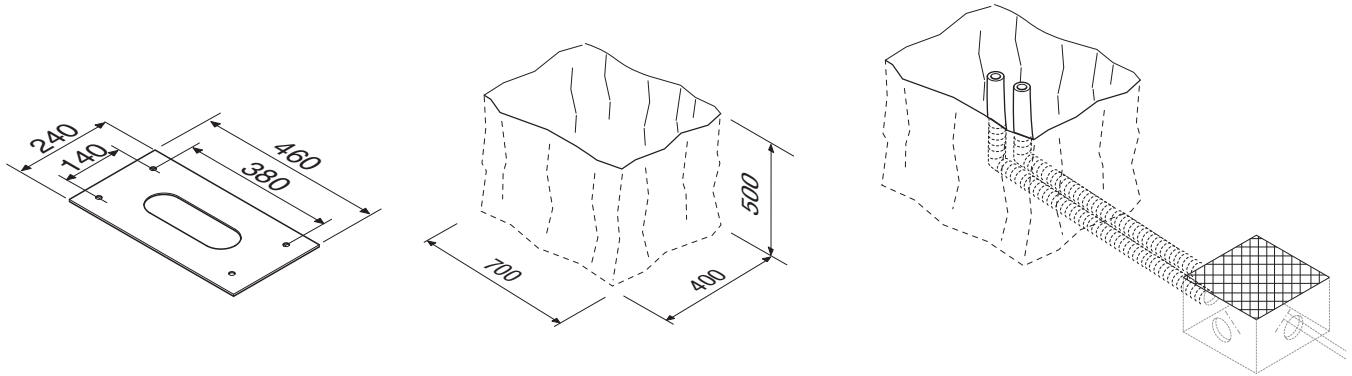

Laying the anchoring plate

Set up a foundation frame that is larger than the anchoring plate.

Fit an iron cage in the foundation frame to reinforce the concrete.

Assemble the anchoring braces to the plate.

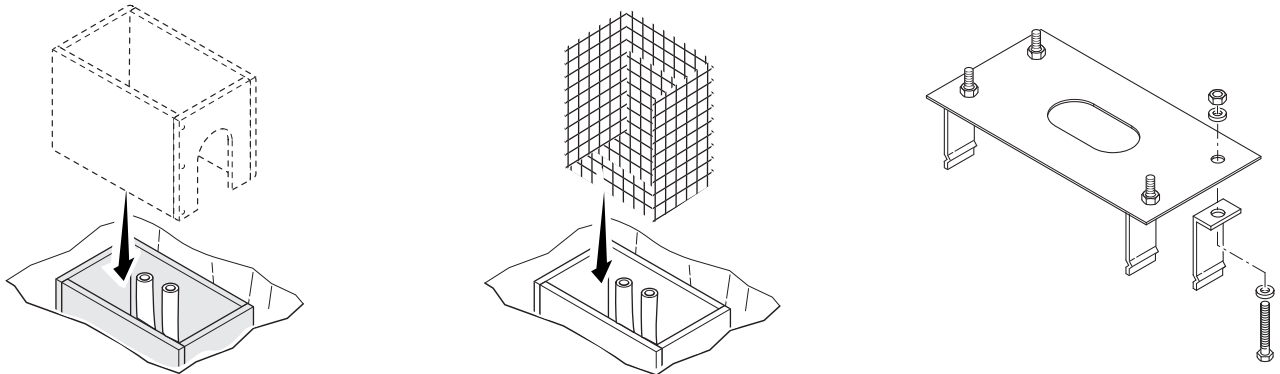

Fit the anchoring plate in the iron cage.

 The tubes must pass through the existing holes.

Cast cement into the foundation frame.

 The plate must be perfectly level and the screw threads completely above surface.

Wait at least 24 hours for the cement to dry.

Remove the foundation frame.

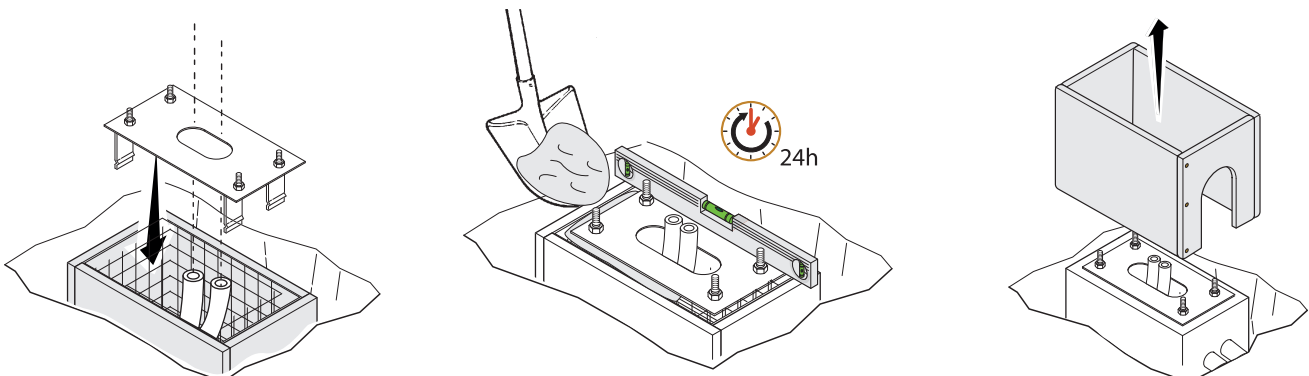

Fill the hole with soil around the concrete block.
Remove the nuts from the screws.
Insert the electrical cables into the tubes until they protrude by about 600 mm.

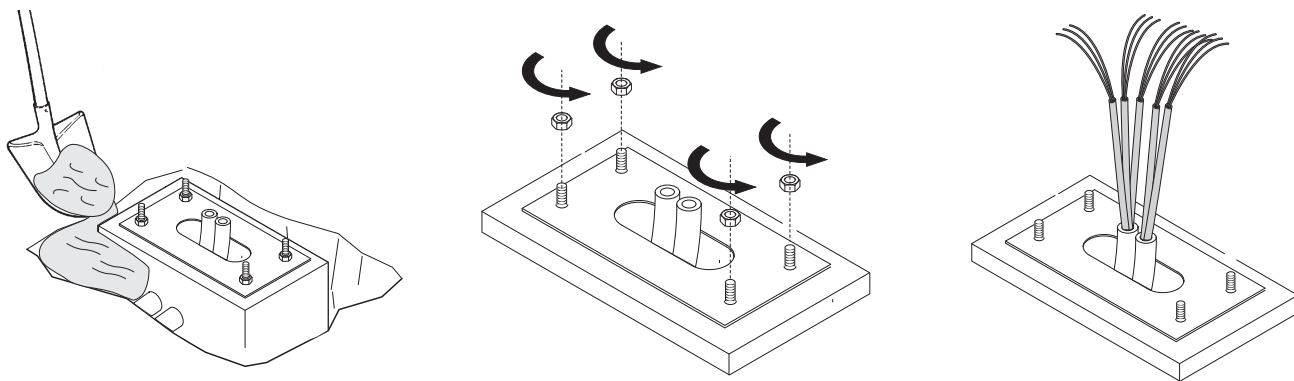

Preparing the barrier

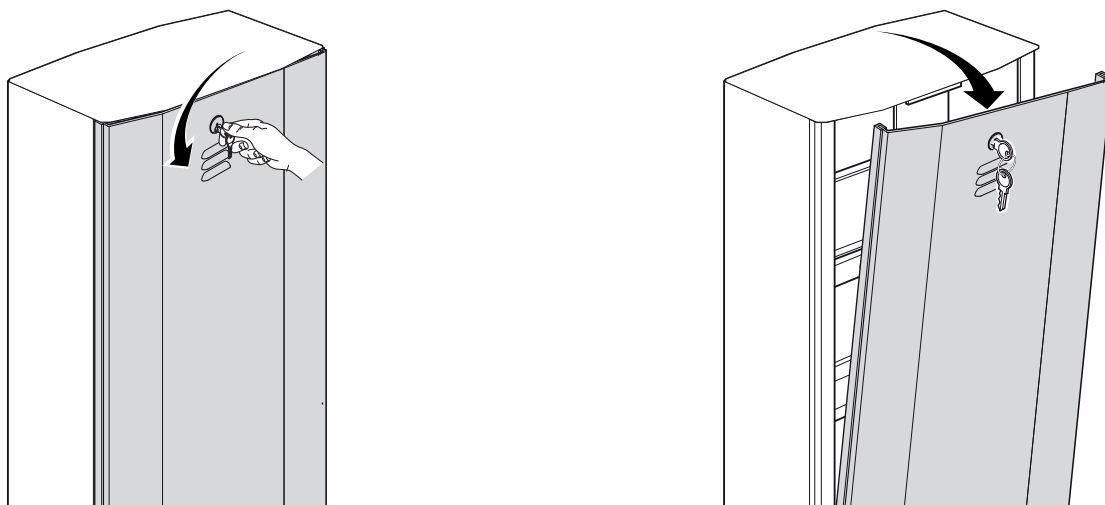

Fastening the barrier

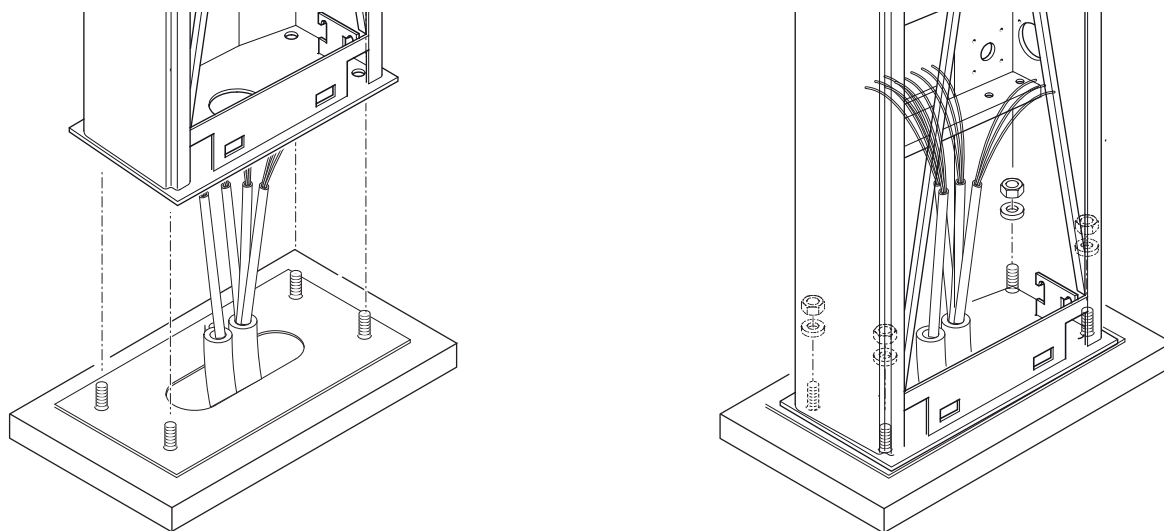

Changing the boom opening direction

 The barrier is set up for installation on the left.

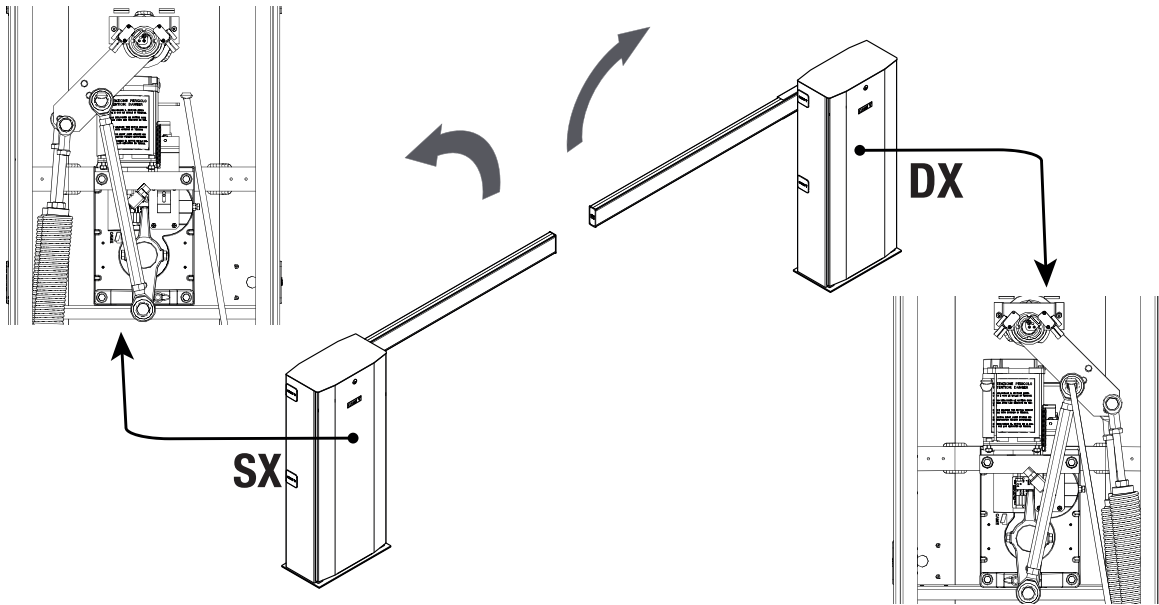

 If the boom has already been assembled, lift it up to a vertical position and remove it.

 Release the gearmotor using the key to run the procedure for changing the boom opening direction.

1 Remove the cover on the micro limit switches and remove the microswitch activation block.
 Unscrew the boom anchoring plate.
 Unscrew the upper mechanical stop and hex screw. Remove the lower mechanical stop, unscrewing the relevant screws.
 Loosen both balance springs and unhook them from the anchoring bracket.
 Release the transmission lever from the lever arm, unscrewing the screw.

2 Turn the gearmotor arm 90°.
 Turn the transmission lever 90° and fix it in place again using the screw.

 Turn it anticlockwise to change the opening from left to right.

 Turn it clockwise to change the opening from right to left.

Reattach the mechanical springs to the bracket.
 Lock the gearmotor.

3 Fit the upper mechanical stop and hex screw on the opposite side.
 Turn the lower mechanical stop 180° and screw it back in place.
 Turn the microswitch activation block 90° and screw it back in place.
 Fit the micro limit switch cover and the boom anchoring plate again.

 Invert the cables connecting the limit microswitches (FC - FA) and the motor phases (M - N) on the electrical panel.

 With the barrier installed, rebalance the boom and redetermine the mechanical limit switches.

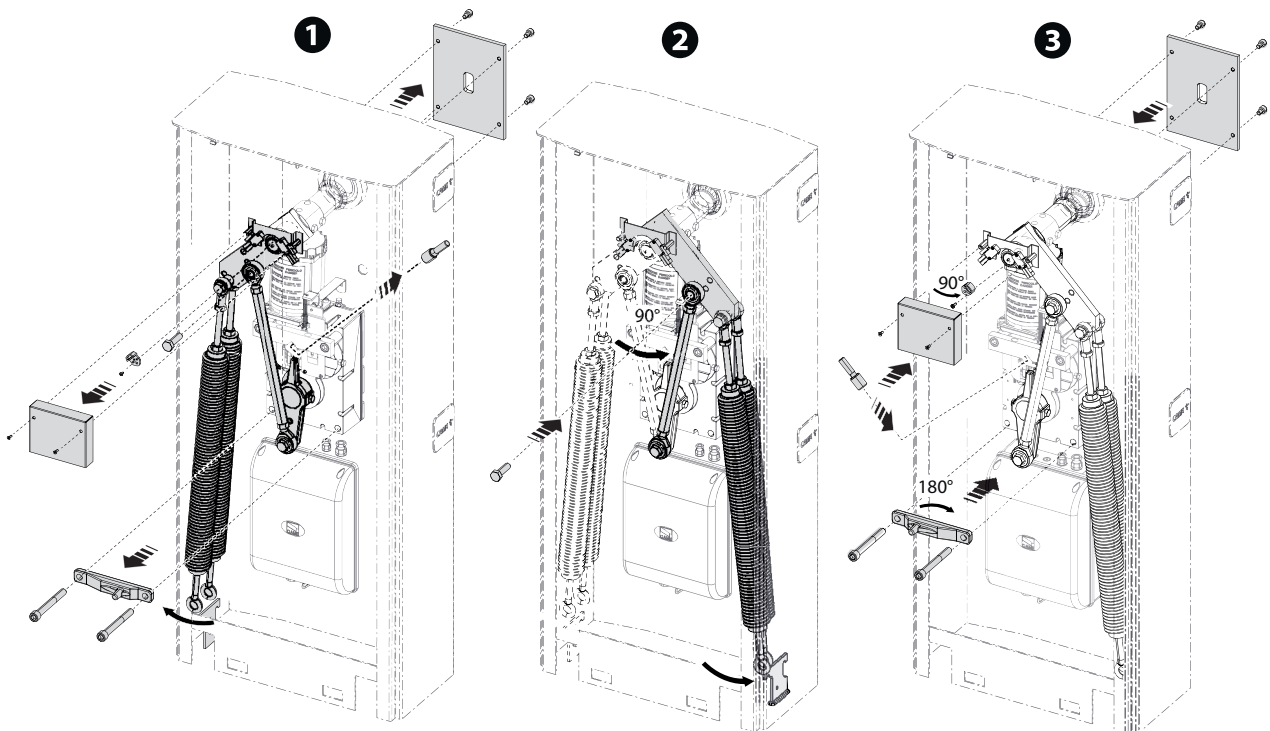

Boom installation

Insert the boom between the boom attachment and the boom anchoring plate and fasten using screws.

 First install the LED strip (where applicable), ONLY THEN fix the flange and the intermediate plate.

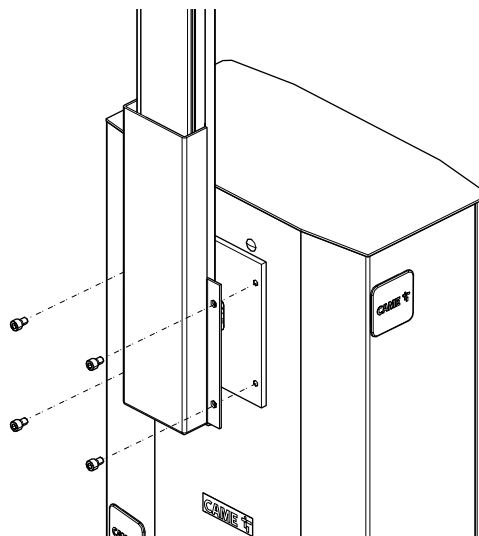
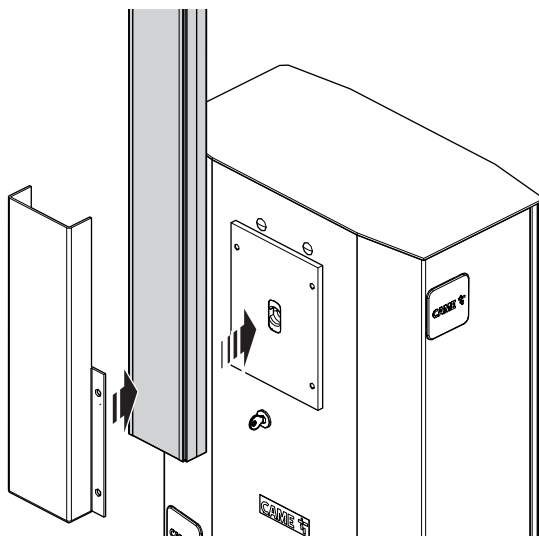

Choosing the hole for fixing the balance spring

 The barrier is supplied as standard with springs (\varnothing 50 mm) fitted in the holes marked B.

Passage width clearance (m)	3 < 4	4 < 5	5 < 6	6 < 6,5
Boom	A	A	B	A B
Boom with warning lights (001G0460)	A	B	A B	
Boom with warning lights and skirt (001G0465)	B	A B	B B	
Boom with warning lights and swing rest (001G02808)	B	A B	B B	

 Simple boom means the boom complete with slot cover, cap and rubber profile.

 If the passage is wider than 3 m, you must use a support for the boom (fixed or mobile).

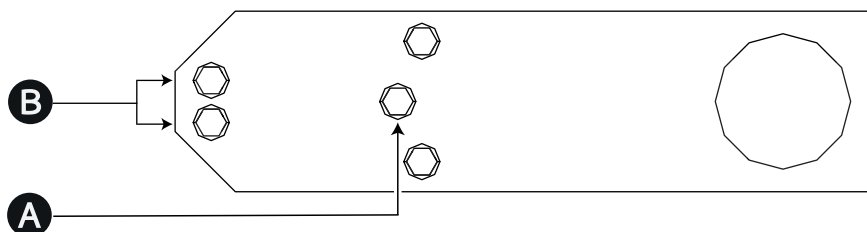

 The fixed rest (001G02807) must be used for passage clearance widths exceeding 3 metres.

 The swing rest 001G02808 and the skirt 001G0465 cannot be used together.

 The DIR photocell support (001G02802) cannot be used with skirt 001G0465 or swing rest 001G02808.

Balancing the boom

- 1 Release the gearmotor.
- 2 Loosen the clamping nut on the rod.
- 3 Manually turn the spring to increase or reduce the traction. The boom should stabilise at 45°.
- 4 Fasten the locknut.

Position the boom vertically.

- 5 Lock the gearmotor

Check the proper working state of the spring. When the boom is vertical, the spring is not taut. When the boom is horizontal, the spring is taut.

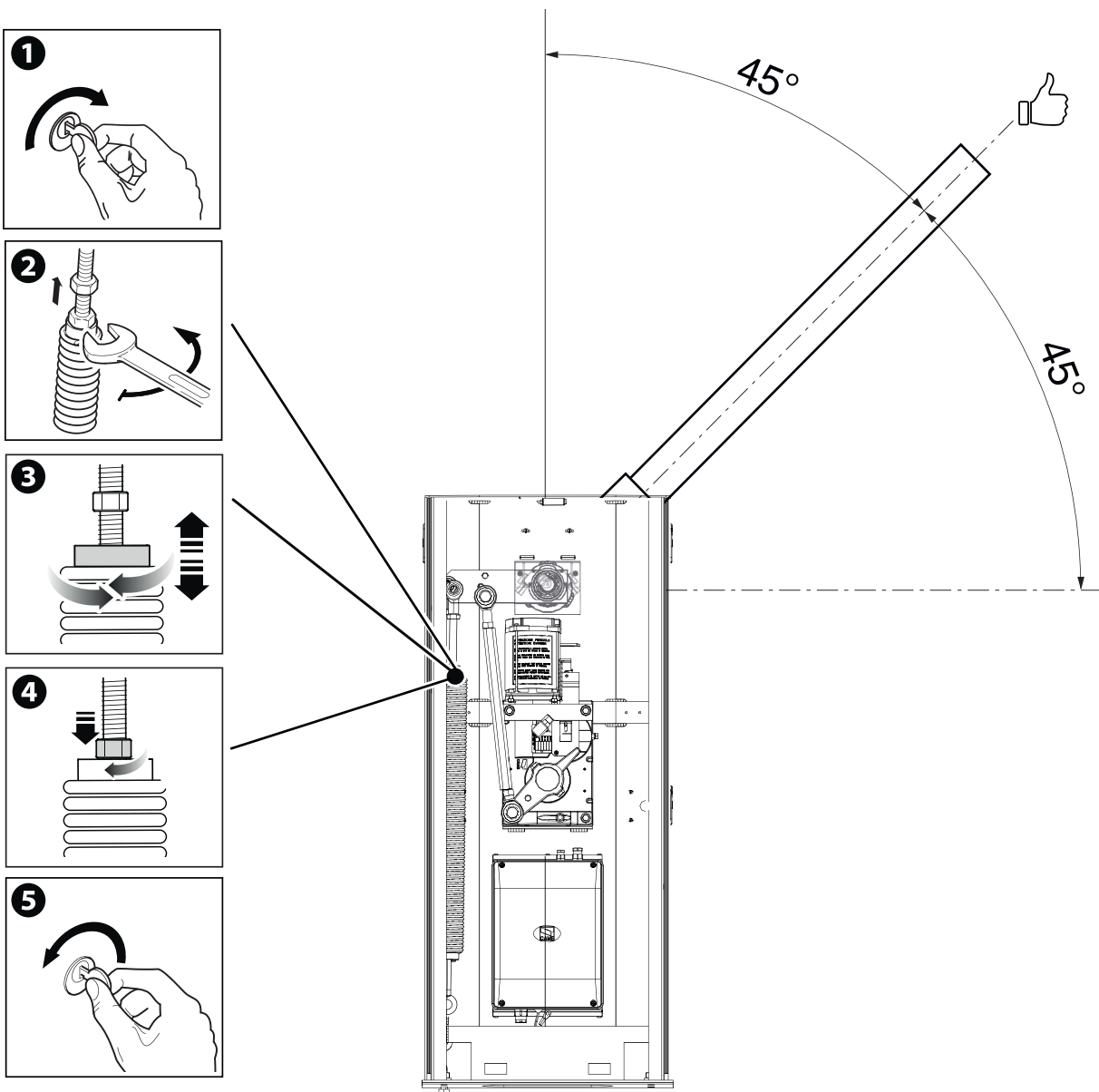

Determining the travel end points with mechanical limit switches

Check that the boom is parallel to the road surface when it is in the closed position and at about 89° when it is in the open position.

Correct the boom's horizontal position

Release the gearmotor.

Open the inspection hatch.

- 1 Turn the mechanical stop until you reach the desired boom position.
- 2 Tighten the hex screw to block the stop in place.

Lock the gearmotor

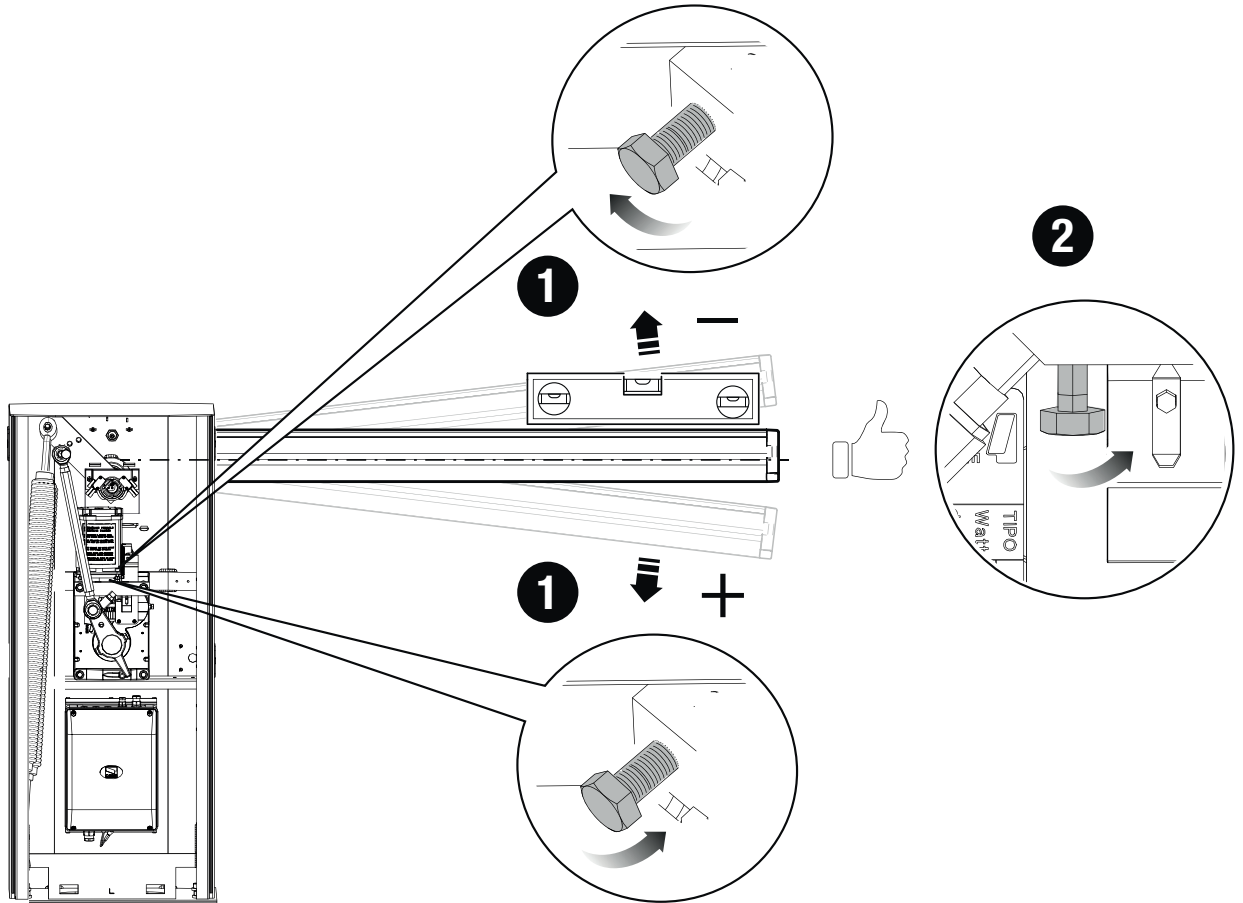

Correct the boom's vertical position

Release the gearmotor.

Open the inspection hatch.

➊ Turn the transmission lever until the boom is in the desired position.

➋ Tighten the nuts to block the transmission lever.

Lock the gearmotor.

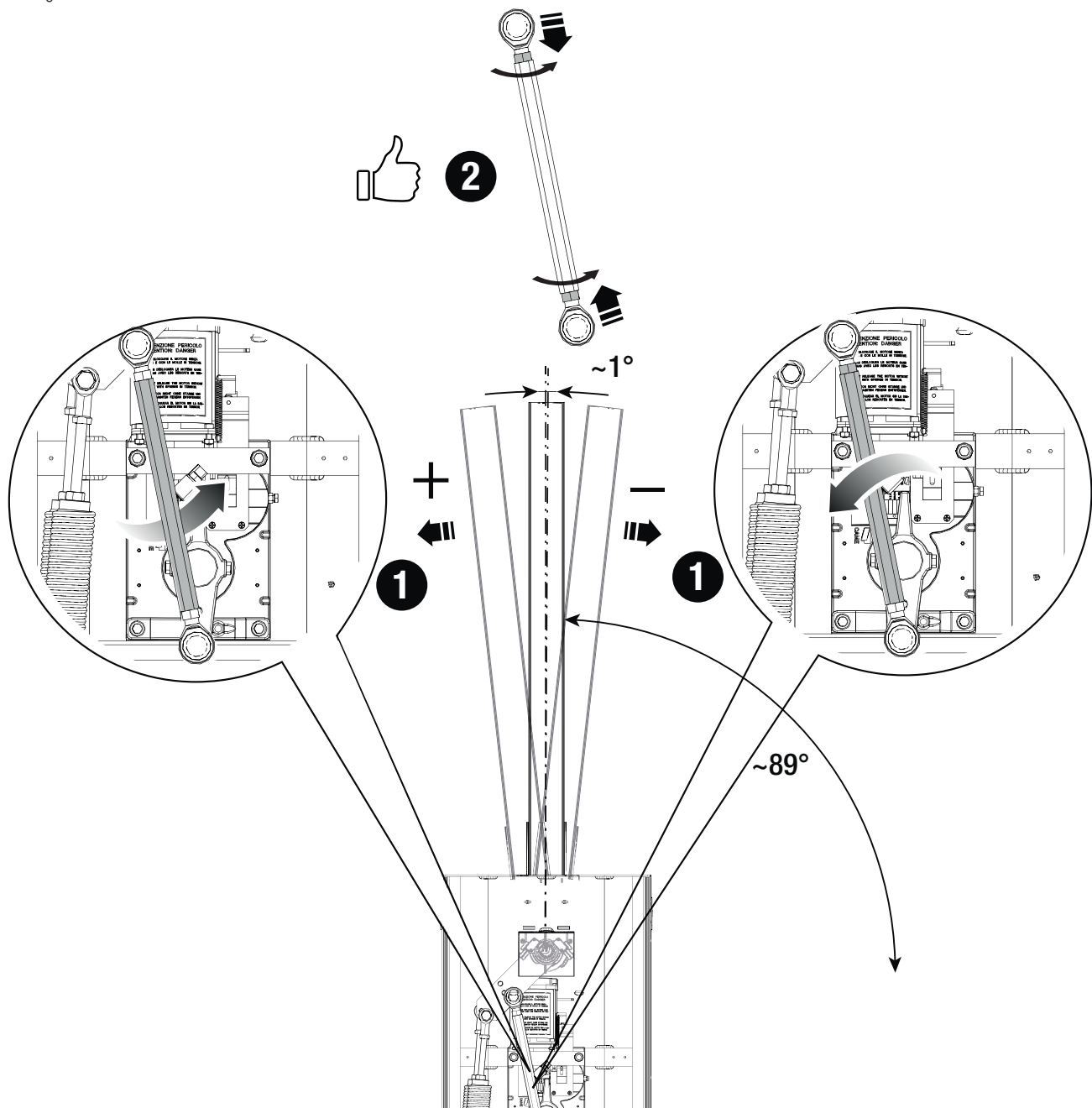

Passing the electrical cables

The electrical cables must not touch any parts that may overheat during use (such as the motor and transformer).
 Make sure that the moving mechanical parts are suitably far away from the wiring.

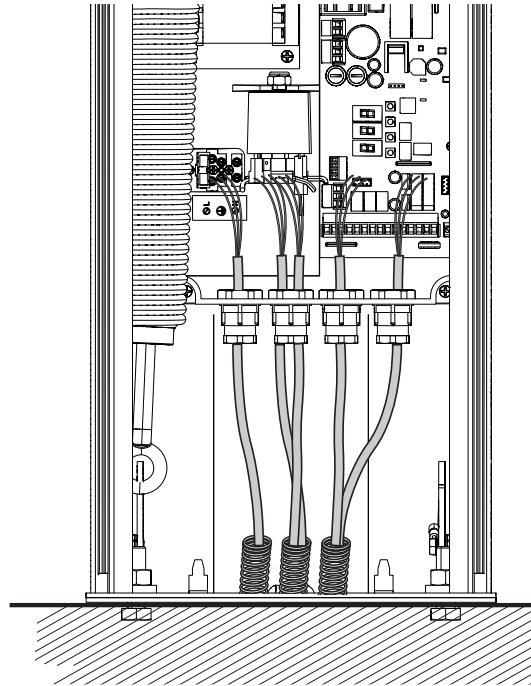

Power supply

Make sure the mains power supply is disconnected during all installation procedures.

⚠ Before working on the control panel, disconnect the mains power supply and remove the batteries, if any.

Connecting to the electrical network

- ⓕ Line fuse
- Ⓛ Phase
- Ⓝ Neutral
- Ⓧ Earth

Power supply output for accessories

The output normally delivers 24 V AC.

The output delivers 24 V DC when the batteries start operating, if they are installed.

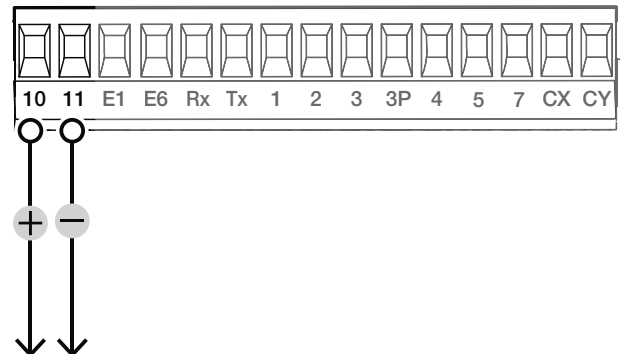
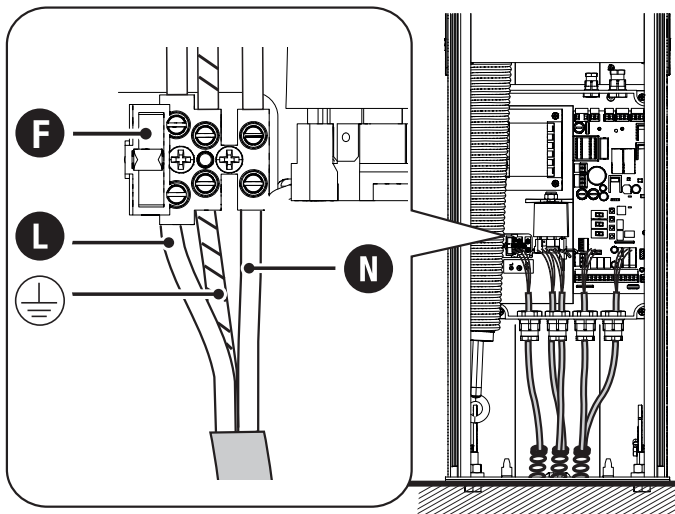

Maximum capacity of contacts

The total power of the outputs listed below must not exceed the maximum output power [Accessories]

Device	Output	Power supply (V)	Power (W)
Accessories	10 - 11	24 AC	40
Additional light	10 - E1	24 AC	25
Flashing beacon	10 - E1	24 AC	25
Operator status warning light	10 - 5	24 AC	3

Command and control devices

1 STOP button (NC contact)

This stops the boom and excludes automatic closing. Use a control device to resume movement.

If the contact is not used, it must be deactivated during programming.

2 Control device (NO contact)

OPEN ONLY function

When the [HOLD-TO-RUN] function is active, the control device must be connected during OPENING.

3 Control device (NO contact)

PARTIAL OPENING function

The contact must only be used for operators working in paired mode.

4 Control device (NO contact)

CLOSE ONLY function

When the [HOLD-TO-RUN] function is active, the control device must be connected during CLOSING.

5 Control device (NO contact)

OPEN-CLOSE function

6 Card reader

7 Transponder selector switch

8 Keypad selector

9 Antenna with RG58 cable

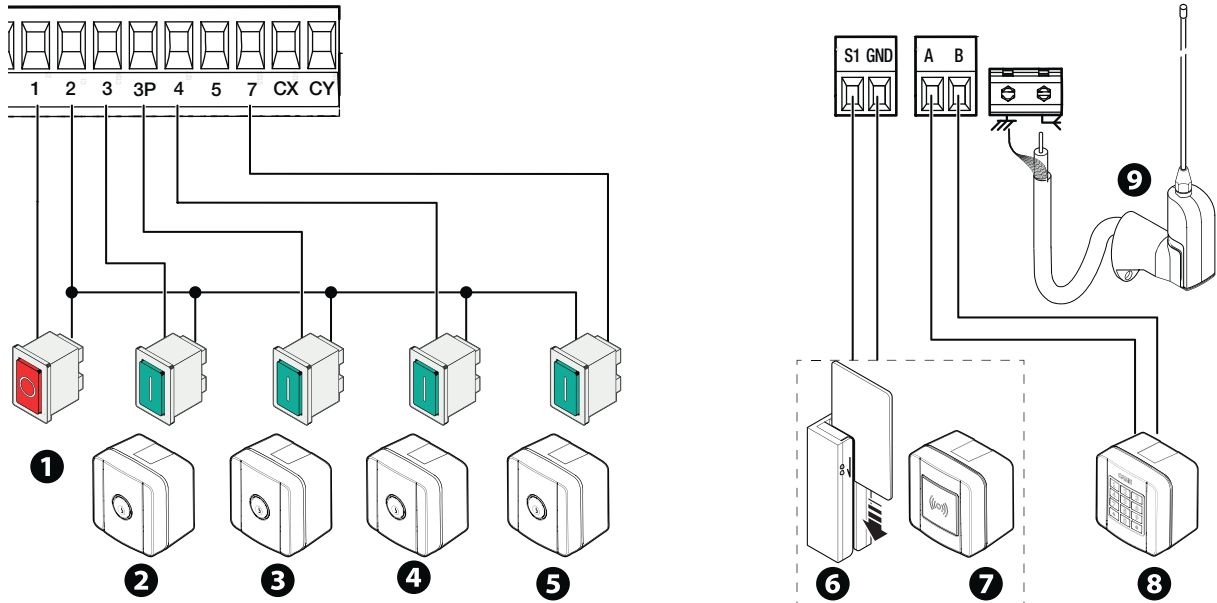

Signalling devices

1 Additional light

It increases the light in the manoeuvring area.

2 Additional flashing beacon

It flashes when the operator opens and closes.

3 Operator status warning light

It notifies the user of the operator status.

4 Rope light

It flashes when the operator opens and closes.

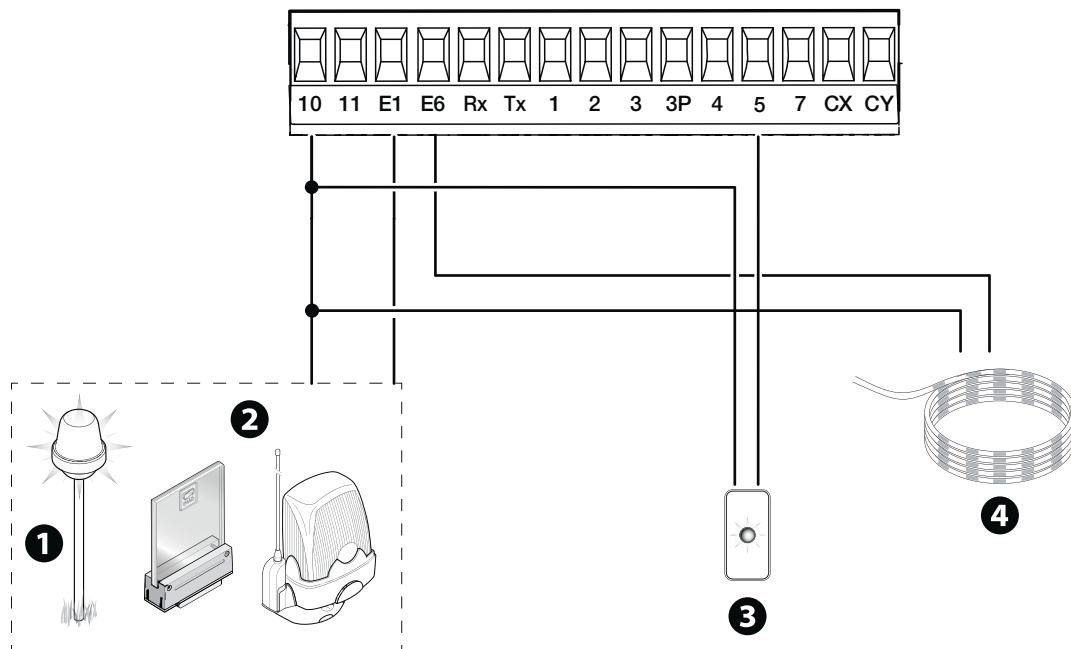

Safety devices

Connect the safety devices to the CX and/or CY inputs.

During programming, configure the type of action that must be performed by the device connected to the input.

If contacts CX and CY are not used, they must be deactivated during programming.

DELTA photocells

Standard connection

Multiple photocell pairs can be connected.

DELTA photocells

Connection with safety test

Multiple photocell pairs can be connected.

See function [F5] Safety devices test.

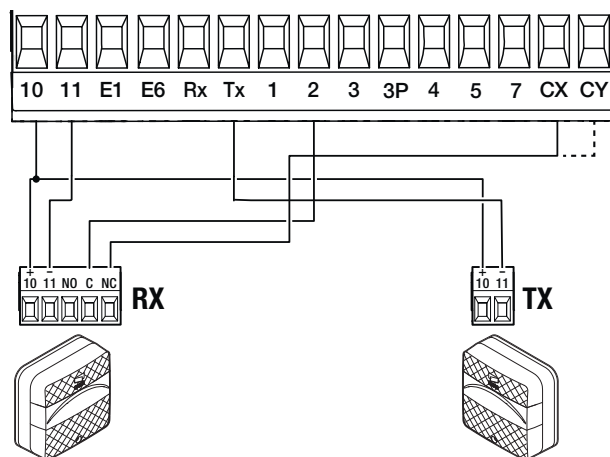
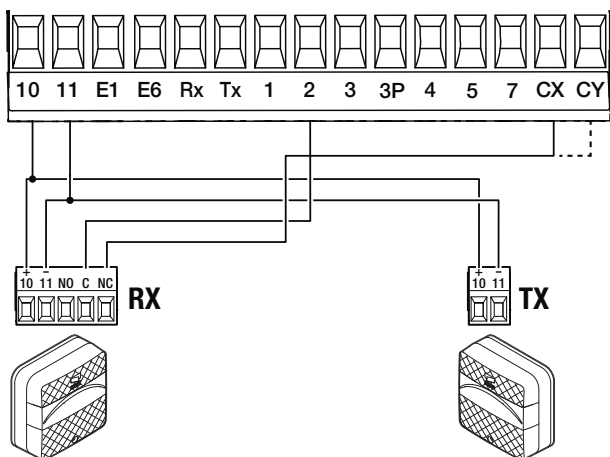

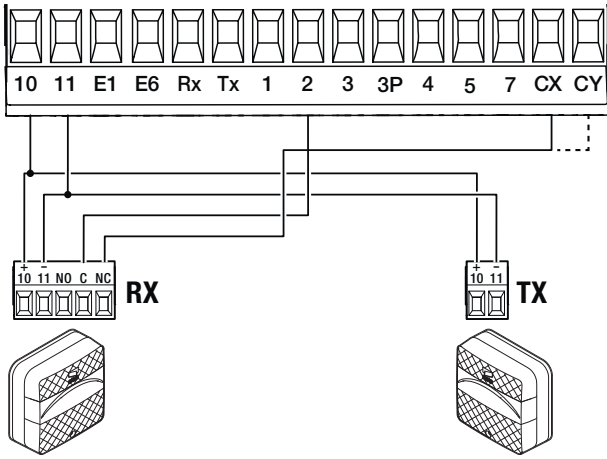

Connection with Sleep Mode

Multiple photocell pairs can be connected.

See function F60, Sleep Mode.

DIR / DELTA-S photocells

Standard connection

Multiple photocell pairs can be connected.

Connection with safety test

Multiple photocell pairs can be connected.

See function [F5] Safety devices test.

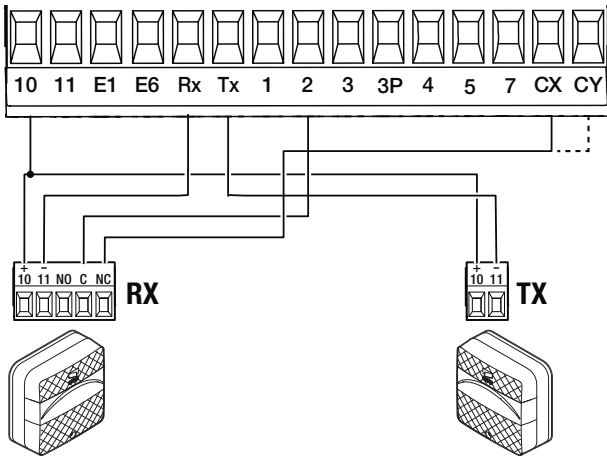
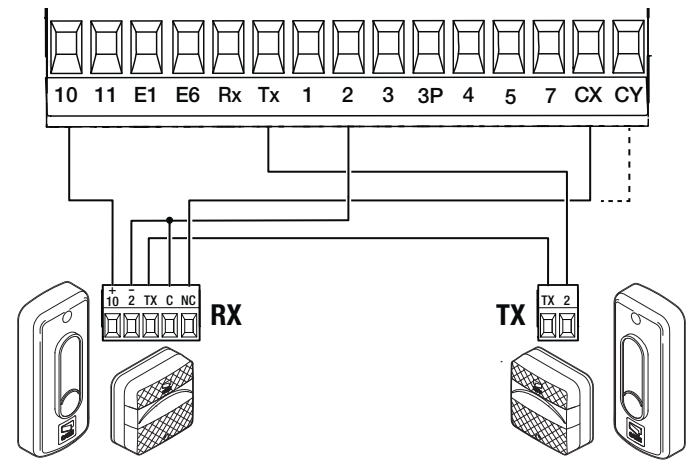
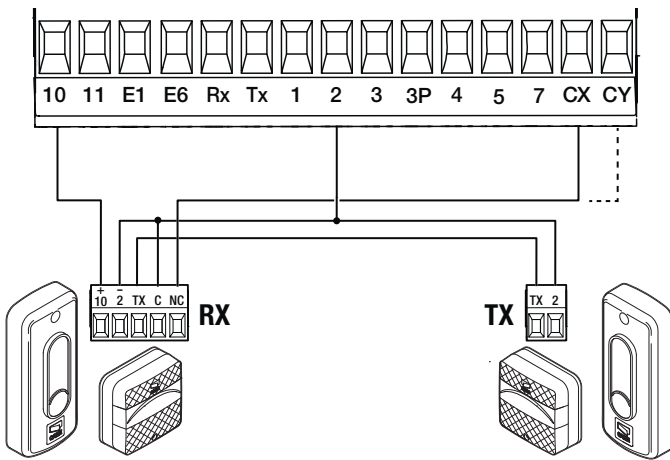

Connection with Sleep Mode

Multiple photocell pairs can be connected.

See function F60, Sleep Mode.

DXR/DLX photocells

Standard connection

Multiple photocell pairs can be connected.

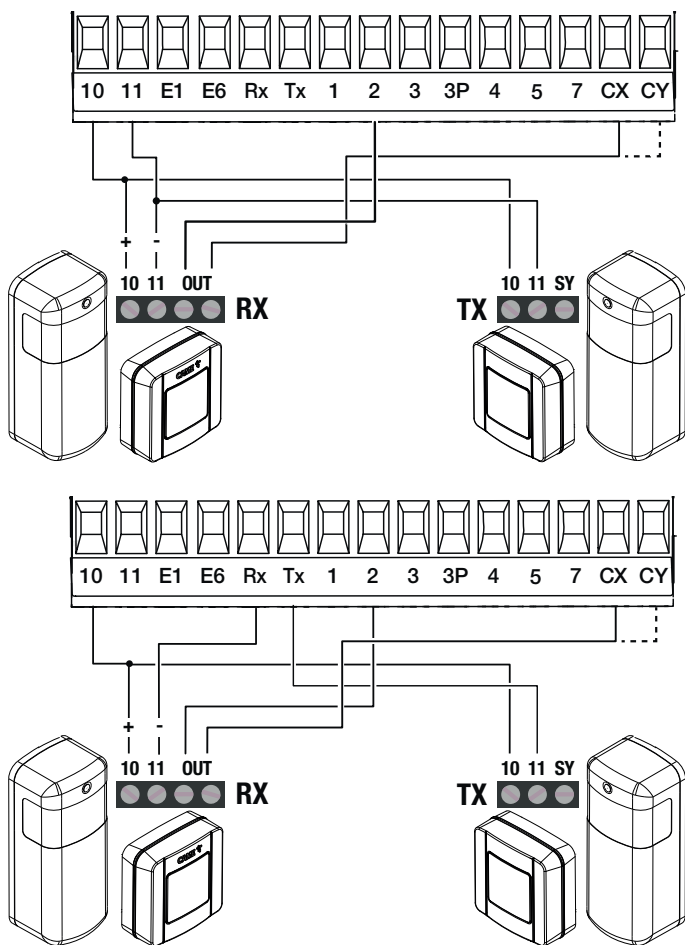

DXR/DLX photocells

Connection with safety test

Multiple photocell pairs can be connected.

See function [F5] Safety devices test.

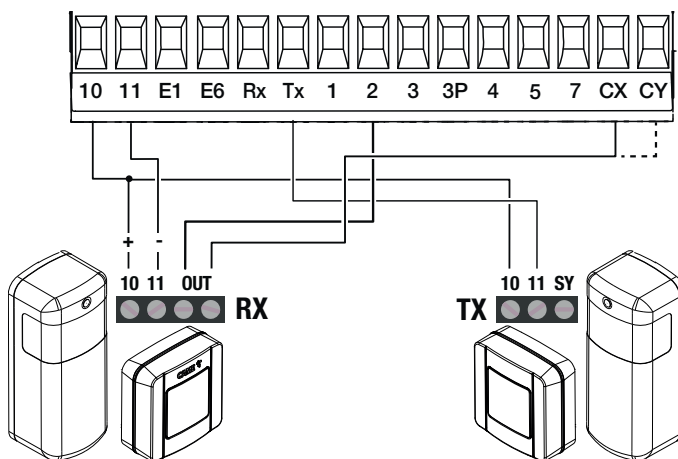

Connection with Sleep Mode

Multiple photocell pairs can be connected.

See function F60, Sleep Mode.

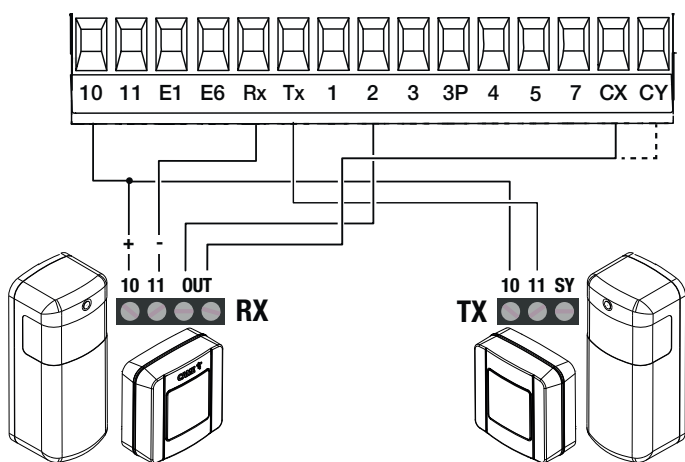

Programming button functions

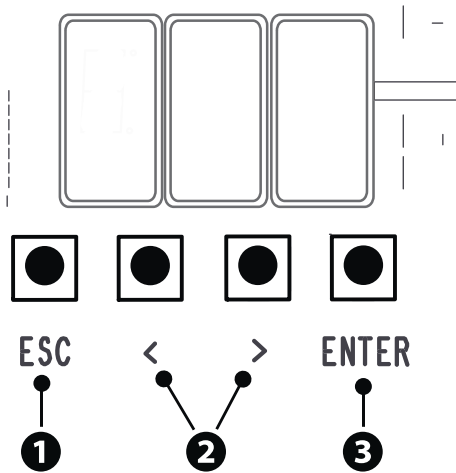

1 ESC button

The ESC button is used to perform the operations described below.
 Exit the menu
 Delete the changes
 Go back to the previous screen

2 <> buttons

The <> buttons are used to perform the operations described below.
 Navigate the menu
 Increase or decrease values

3 ENTER button

The ENTER button is used to perform the operations described below.
 Access menus
 Confirm choice

Getting started

Once the electrical connections have been made, proceed with commissioning. Only skilled and qualified staff may perform this operation. Check the warning and safety devices are working properly. Make sure that there are no obstacles in the way. Power up and proceed with the operations indicated below.

F1 Total stop

After powering up the system, the first manoeuvre is always to open the gate. Wait for the manoeuvre to be completed. Press the ESC button or STOP button immediately in the event of any faults, malfunctions, strange noises or vibrations, or unexpected behaviour in the system. At the end of commissioning, check the correct operation of the device using the buttons near the display. Check that the accessories also work correctly.

Functions menu

Total stop

This stops the boom and excludes automatic closing. Use a control device to resume movement.

F1	Total stop	0 =Deactivated (Default) 1 = Activated
-----------	-------------------	---

CX input

Associate a function with the CX input.

F2	CX input	0 =Deactivated (Default) 1 = C1 = Reopening while closing (Photocells) 4 = C4 = Obstacle wait (Photocells) 5 = C5 = Immediate closing at the opening travel end 9 = C9 = immediate closing at the travel end during opening with obstacle waiting, during closing
-----------	-----------------	---

CY input

Associate a function with the CY input.

F3	CY input	0 =Deactivated (Default) 1 = C1 = Reopening while closing (Photocells) 4 = C4 = Obstacle wait (Photocells) 5 = C5 = Immediate closing at the opening travel end 9 = C9 = immediate closing at the travel end during opening with obstacle waiting, during closing
-----------	-----------------	---

Safety devices test

Check that the photocells connected to the inputs are operating correctly, after each opening and closing command.

F5	Safety devices test	0 =Deactivated (Default) 1 = CX 2 = CY 3 = CX+CY
-----------	----------------------------	---

Hold-to-run

With the function active, the operator stops moving (opening or closing) when the control device is released.

 When the function is active, it excludes all other control devices.

F6	Hold-to-run	0 =Deactivated (Default) 1 = Activated
-----------	--------------------	---

Obstacle with motor stopped

With the function active, the boom remains stopped if the safety devices detect an obstacle. The function activates with: closed boom, open boom or after a complete stop.

F9	Obstacle with motor stopped	0 =Deactivated (Default) 1 = Activated
-----------	------------------------------------	---

Open warning light

Barrier status warning. Device connected to the 10-5 output.

F10	Open warning light	0 = Warning light on (default) - The light stays on when the boom is moving or open. 1 = Warning light flashing - The warning light flashes every half a second when the boom is opening and remains on when the boom is open. The light flashes every second when the boom is closing, and remains off when the boom is closed.
------------	---------------------------	---

Sensor type

Set the type of control device.

F14	Sensor type	0 = Transponder 1 = Keypad (Default)
------------	--------------------	---

Flashing rope light

Choose how you would like the barrier status to be signalled using the rope light flash settings.

F15	Flashing rope light	0 = The rope light flashes when the boom is moving (Default). 1 = The rope light flashes when the boom is moving and when closed.
------------	----------------------------	--

Light E1

Choose the type of device connected to the output.

F18	Light E1	0 =Flashing beacon (Default) 1 = Cycle light  This parameter does not appear if there [Automatic Close] function is deactivated. 2 = Courtesy light. The lighting device remains on for the time set for the [Courtesy time] function.
------------	-----------------	---

Automatic closure

Set the time before automatic closure is activated, once the opening travel end point has been reached.

 The function does not work if any of the safety devices are triggered when an obstacle is detected, after a complete stop, during a power outage or if there is an error.

F19	Automatic closure	0 =Deactivated (Default) From 1 to 180 seconds
------------	--------------------------	---

Pre-flashing time

Set the time for which the beacon is activated before each manoeuvre.

F21	Pre-flashing time	0 =Deactivated (Default) 1 to 10 seconds
------------	--------------------------	---

Operating time

Set the gearmotor working time during opening and closing.

F22	Operating time	5 to 120 seconds (default 20 seconds)
------------	-----------------------	---------------------------------------

Courtesy time

Set the lighting device operation time.

F25	Courtesy time	60 to 180 seconds (Default 180 seconds)
------------	----------------------	---

Opening and closing speed

Set the opening and closing speed.

 For booms complete with accessories (swing rest and/or skirt), reduce the speed.

F28	Opening and closing speed	MIN = minimum speed MED = average speed MAX = maximum speed XMA = maximum speed for boom <3m
------------	----------------------------------	---

Slow-down speed

Set the slowdown speed.

F30	Slow-down speed	MIN = minimum slowdown speed (Default) MED = average slowdown speed MAX = maximum slowdown speed
------------	------------------------	--

Calibration speed

Set the travel self-learning speed (percentage of maximum speed) and first manoeuvre speed

F33	Calibration speed	20% to 30%
------------	--------------------------	------------

Travel sensitivity

Adjust the obstruction detection sensitivity during boom travel.

F34	Travel sensitivity	10% to 100% (Default 100%) - 10% = maximum sensitivity - 100% = minimum sensitivity
------------	---------------------------	---

Slowdown sensitivity

Adjust the obstacle-detection sensitivity level during slowdown.

F35	Slowdown sensitivity	10% to 100% (Default 98%) - 10% = maximum sensitivity - 100% = minimum sensitivity
-----	----------------------	--

RSE

Configure the function to be performed by the card inserted in the RSE1 connector.

F49	RSE	0 =Deactivated (Default) 1 = Paired 2 = Compass 3 = CRP/CAME KEY
-----	-----	---

Save data

Save user data, timings and configurations to the memory device (memory roll or USB key).

F50	Save data	0 =Deactivated (Default) 1 = Activated
-----	-----------	---

Read data

Upload user data, timings and configurations from the memory device (memory roll or USB key).

F51	Read data	0 =Deactivated (Default) 1 = Activated
-----	-----------	---

Transferring MASTER-SLAVE parameters

Enable the sharing of parameters programmed on the Master barrier with the Slave barrier.

 This only appears if the F49 function is set to Paired or Alternate.

F52	Transferring MASTER-SLAVE parameters	0 =Deactivated (Default) 1 = Activated
-----	--------------------------------------	---

CRP address

Assign a unique identification code (CRP address) to the control board. It is used where there are multiple operators connected via CRP.

F56	CRP address	from 1 to 255
-----	-------------	---------------

Sleep mode

This reduces the consumption of the photocells when they are in standby.

F60	Sleep mode	0 =Deactivated (Default) 1 = Activated
-----	------------	---

Pre-flashing

Choose the type of manoeuvre that activates the flashing beacon in advance.

 Set how much earlier the flashing beacon is activated under the function [Pre-flashing time].

F61	Pre-flashing	0 = when opening and closing (Default) 1 = only when closing 2 = only when opening
-----	--------------	--

RSE speed

Set the remote connection system communication speed on the RSE port.

F63		0 = 1200 bps 1 = 2400 bps 2 = 4800 bps 3 = 9600 bps 4 = 14400 bps 5 = 19200 bps 6 = 38400 bps (default) 7 = 57600 bps 8 = 115200 bps
------------	--	--

New user

Register a maximum of 25 users and assign a function to each one.

 The operation can be carried out by using a transmitter or another control device. The boards that manage the control devices (AF - R700 - R800) must be inserted into the connectors.

U1	New user	1 = Step-by-step 3 = Open 4 = Partial opening  When the barrier is in [Paired] mode, the [Partial opening] command opens the Master barrier. Choose the function to be assigned to the user. Press ENTER to confirm. You will be asked to enter your user code. Send the code from the control device. Repeat the procedure to add other users.
-----------	-----------------	--

Remove user

Remove one of the registered users.

U2	Remove user	Use the arrows to choose the number associated with the user you want to remove. No.: 1 > 25 Alternatively, the control device associated with the user you want to remove can be activated. Press ENTER to confirm.
-----------	--------------------	---

Remove all

Remove all registered users.

U3	Remove all	0 = Deactivated (Default) 1 = Activated
-----------	-------------------	--

Radio decoding

Choose the type of radio coding for the transmitters enabled to control the operator.

 If you choose the type of radio coding for the transmitters [Rolling code] or [TW key block], any transmitters with a different type of radio coding saved previously will be deleted.

U4	Radio decoding	1 = All (Default) 2 = Rolling code 3 = TW key block
-----------	-----------------------	---

Parameter reset

Restore factory settings except for the functions: [Radio decoding], [Boom length] and the settings related to travel calibration.

A4	Parameter reset	0 =Deactivated (Default) 1 = Activated
----	-----------------	---

Manoeuvre counter

View the number of manoeuvres performed by the operator (1 = 1000 manoeuvres).

A5	Manoeuvre counter	1 = 1000 maneuvers
----	-------------------	--------------------

FW version

Display the firmware version number.

H1	FW version	
----	------------	--

Import/export data

❶ Insert the MEMORY ROLL card into the corresponding connector on the control board.

❷ Press the “Enter” button to access programming.

❸ Use the arrows to choose the desired function.

-F50

Save user data, timings and configurations to the memory device (memory roll or USB key).

-F51

Upload user data, timings and configurations from the memory device (memory roll or USB key).

📖 The functions are displayed only when a MEMORY ROLL card is inserted.

⚠ Before inserting and removing the MEMORY ROLL card, DISCONNECT THE MAINS POWER SUPPLY TO THE LINE.

📖 Remove the MEMORY ROLL card after the data has been loaded.

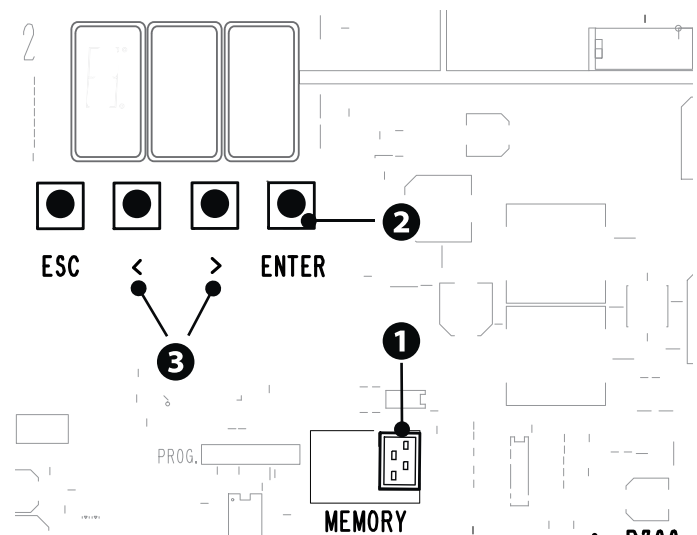

FINAL OPERATIONS

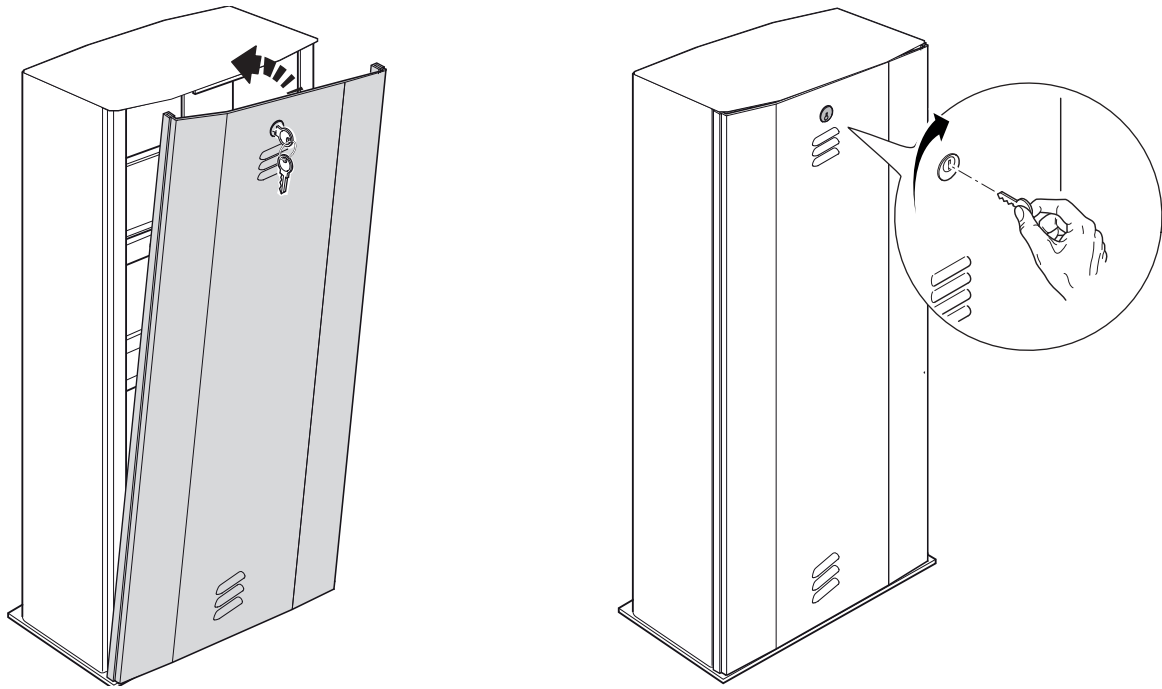

PAIRED OPERATION

Two connected operators are controlled with one command.

Electrical connections

Connect the two electronic boards with a UTP CAT 5 cable.
Fit an RSE card on both control boards using the RSE connector.
Connect up the electrics for the devices and accessories.

- For information on connecting the electrics for the devices and accessories, please see the “ELECTRICAL CONNECTIONS” section.
- The devices and accessories must be connected to the control board which will be set as the MASTER.
- Deactivate function F19 on the SLAVE operator control panel.

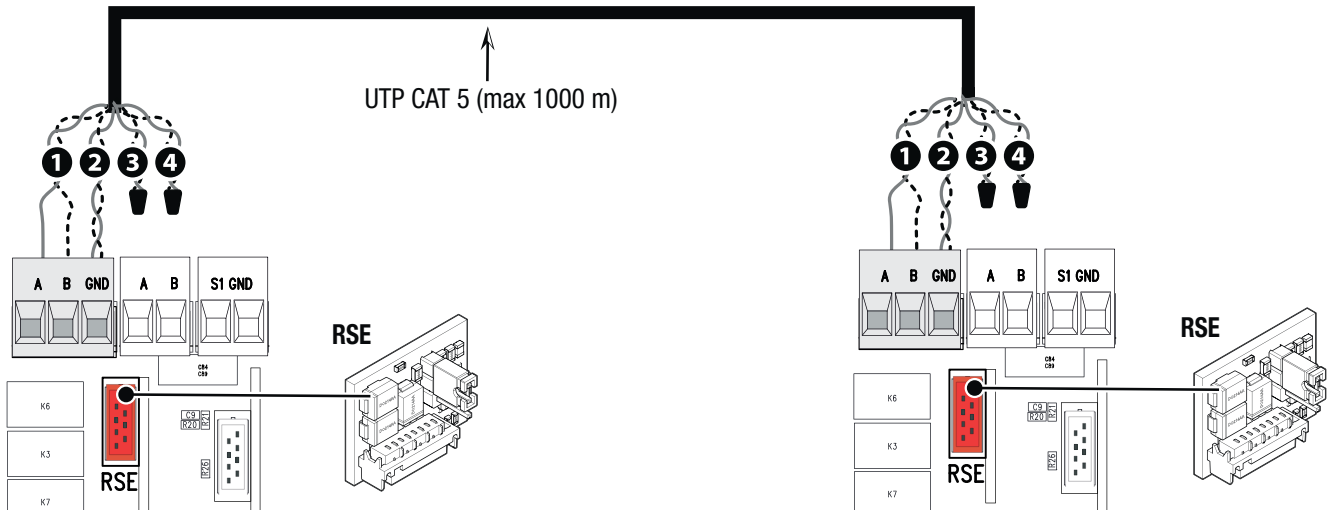

Programming

All programming operations described below must be performed only on the control board set as the MASTER.

- Select function F49.
- Press ENTER to confirm.
- Select 1.
- Select function F52.
- Select 1.

Saving users

- 📖 All save user operations must be performed only on the control board set as the MASTER.
- 📖 For user storage operations, see function U1.

Operating modes

- 1 STEP-BY-STEP or OPEN ONLY command
- 2 PARTIAL OPENING command (2-3P)

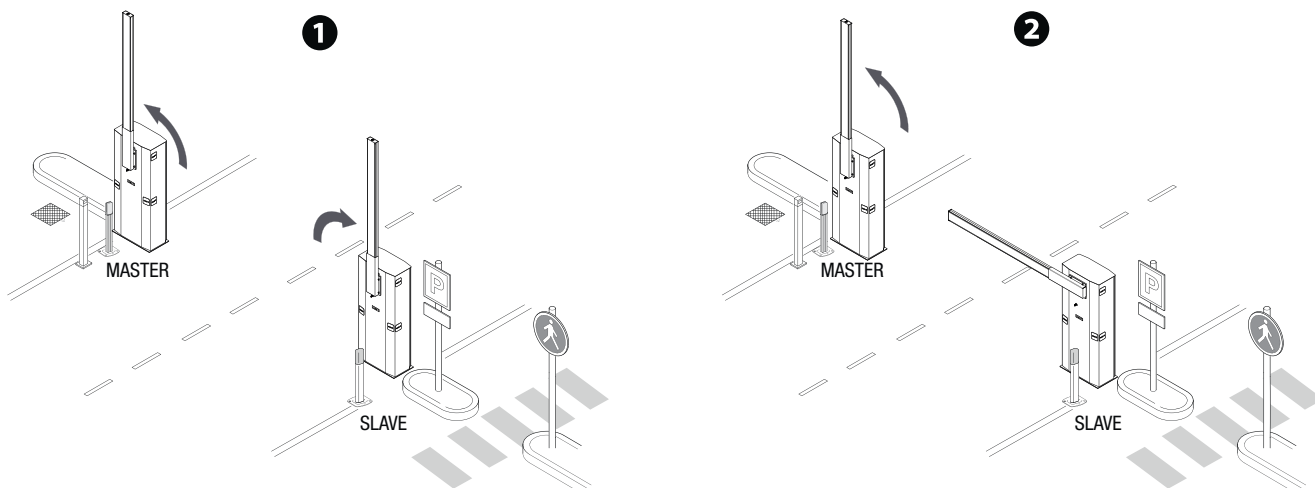

ALTERNATE OPERATION

The first barrier opens, the vehicle passes, the first barrier closes, the second barrier opens, the vehicle passes and the second barrier closes.

Electrical connections

Connect the two electronic boards with a UTP CAT 5 cable.
Fit an RSE card on both control boards using the RSE connector.

Connect up the electrics for the devices and accessories.

📖 For information on connecting the electrics for the devices and accessories, please see the “ELECTRICAL CONNECTIONS” section.

📖 The control and safety devices must be connected on both electronic boards.

📖 Deactivate function F19 on the SLAVE operator control panel.

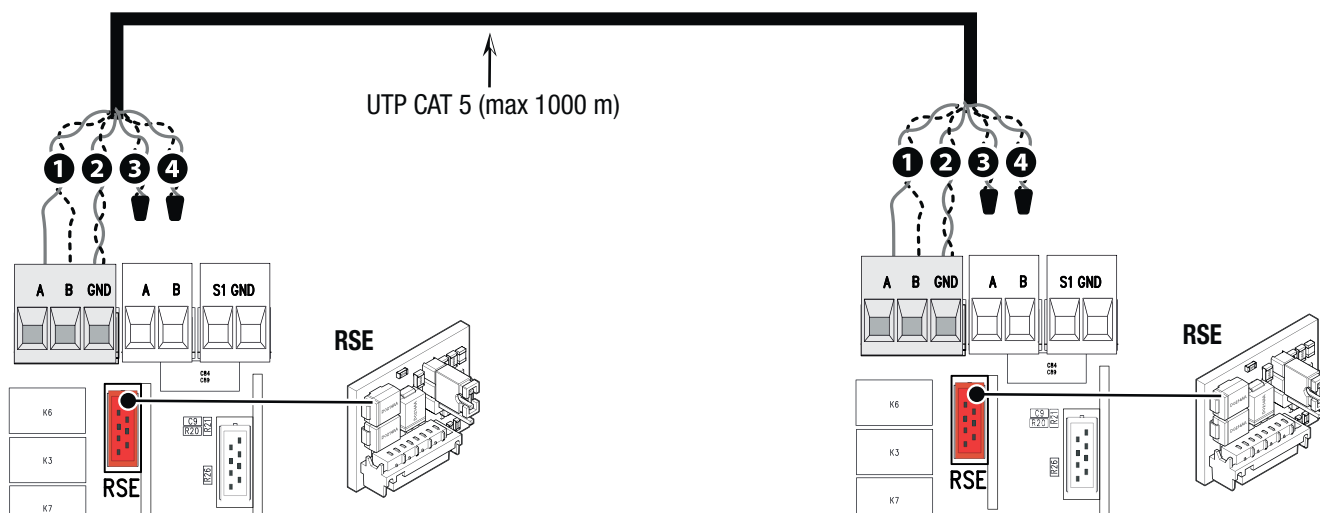

Programming

 All programming operations described below must be performed only on the control board set as the MASTER.

Select function F49.

Press ENTER to confirm.

Select 2.

Select function F52.

Select 1.

Saving users

 All save user operations must be performed only on the control board set as the MASTER.

 For user storage operations, see function U1.

Operating modes

 The MASTER barrier is marked A; the SLAVE barrier is marked B.

1 ONLY OPEN command (2-3) on barrier A

 Barrier B opens automatically when barrier A closes.

1

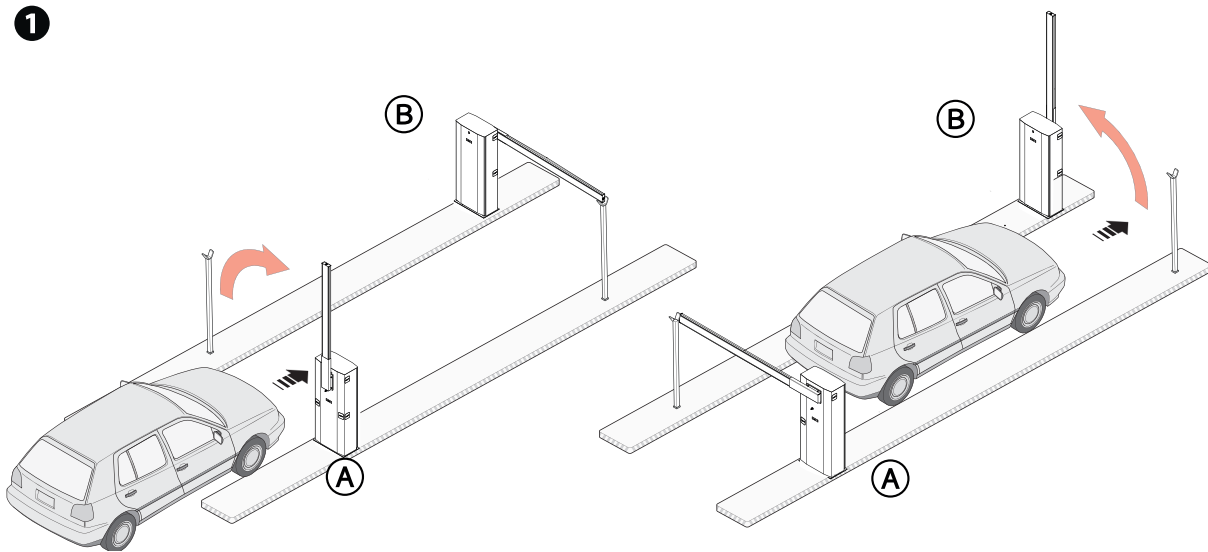

2 PARTIAL/PEDESTRIAN OPENING command (2-3P) on barrier B

 Barrier A opens automatically when barrier B closes.

2

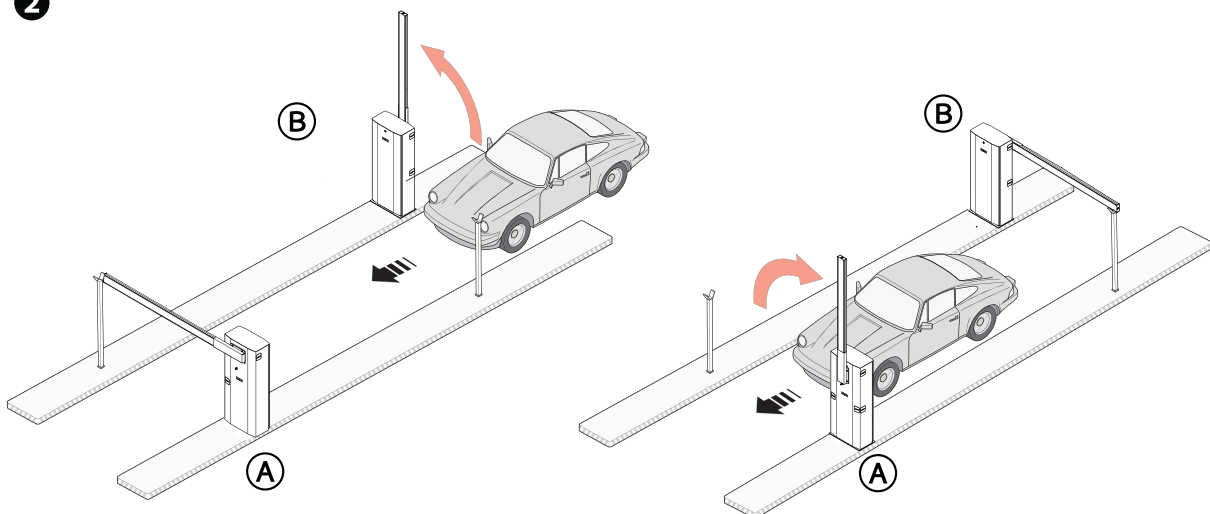

3 STEP-BY-STEP command (2-7) on barrier A or B for emergency opening

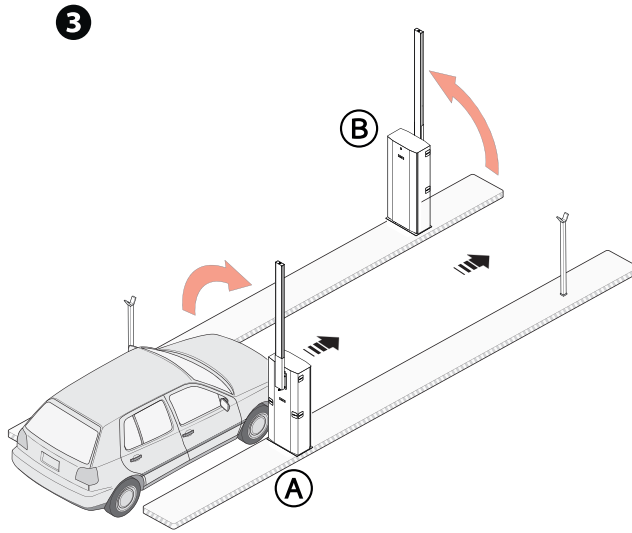

ERROR MESSAGES

E4	Service test failure error
E6	Maximum number of detected obstructions
E7	Transformer overheating Release mechanism activated Open contact on thermal terminal
E8	Both limit switches are open
E15	Incompatible transmitter error

MCBF

- ⚠ Before carrying out any cleaning or maintenance, or replacing any parts, disconnect the device from the power supply.
- ⚠ This document informs the installer of the checks that must be carried out during maintenance.
- ⚠ If the barrier is not used for long periods of time, e.g. for installations at sites with seasonal closures, release the spring and remove the boom.
- 📖 For information on correct installation and adjustments, please see the product installation manual.
- 📖 For information on choosing products and accessories, please see our product catalogue.
- 📖 If the barrier with an articulated joint is used, check that the moving parts of the joint are in good condition. Replace them if necessary.

Every 50,000 cycles and, in any case, every 6 months of operation, you must perform the maintenance indicated below.

- Perform a general and complete check of the tightness of the nuts and bolts.
- Lubricate the spring when it is fully extended.
- Check the 45° boom balance and if necessary tension the balance spring, adjusting its traction operating on the hooking tie rods.
- Grease all of the moving mechanical parts.
- Check the warning and safety devices are working properly.
- Check for any wear on the moving mechanical parts and check that they are working properly.
- Check the cables are intact and connected correctly.

Every 500,000 cycles and, in any case, every 5 years of operation, you must perform the maintenance work indicated below.

- Replace the balance spring.

CAME 

CAME.COM

CAME S.P.A.

Via Martiri della Libertà, 15
31030 Dosson di Casier
Treviso – Italy
Tel. (+39) 0422 4940
Fax (+39) 0422 4941