

Operator for swing gates

FA01776-EN

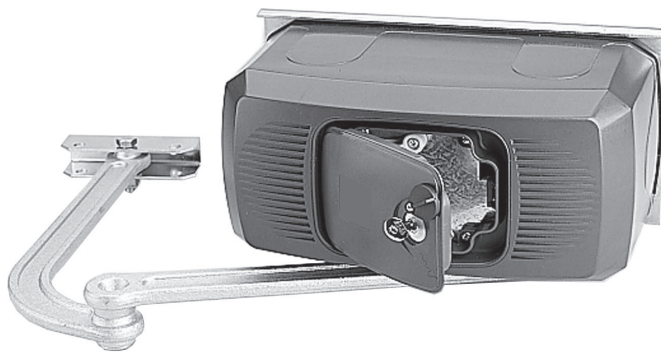

F1000-F1100

INSTALLATION MANUAL



WARNING!
important safety instructions for people:
READ CAREFULLY!



PREMISE

- EMPLOY THIS PRODUCT ONLY FOR THE USE FOR WHICH IT WAS EXPRESSLY MADE. ANY OTHER USE IS DANGEROUS. CAME S.p.A. IS NOT LIABLE FOR ANY DAMAGE CAUSED BY IMPROPER, WRONGFUL AND UNREASONABLE USE
- KEEP THESE WARNINGS TOGETHER WITH THE INSTALLATION AND OPERATION MANUALS THAT COME WITH THE OPERATOR.

BEFORE INSTALLING

(CHECKING WHAT'S THERE: IF YOUR EVALUATION IS NEGATIVE, DO NOT PROCEED BEFORE HAVING COMPLIED WITH ALL SAFETY REQUIREMENTS)

- CHECK THAT THE AUTOMATED PARTS ARE IN GOOD MECHANICAL ORDER, THAT THE OPERATOR IS LEVEL AND ALIGNED, AND THAT IT OPENS AND CLOSES PROPERLY. MAKE SURE YOU HAVE SUITABLE MECHANICAL STOPS
- IF THE OPERATOR IS TO BE INSTALLED AT A HEIGHT OF OVER 2.5 M FROM THE GROUND OR OTHER ACCESS LEVEL, MAKE SURE YOU HAVE ANY NECESSARY PROTECTIONS AND/OR WARNINGS IN PLACE
- IF ANY PEDESTRIAN OPENINGS ARE FITTED INTO THE OPERATOR, THERE MUST ALSO BE A SYSTEM TO BLOCK THEIR OPENING WHILE THEY ARE MOVING
- MAKE SURE THAT THE OPENING AUTOMATED DOOR OR GATE CANNOT ENTRAP PEOPLE AGAINST THE FIXED PARTS OF THE OPERATOR
- DO NOT INSTALL THE OPERATOR UPSIDE DOWN OR ONTO ELEMENTS THAT COULD YIELD AND BEND. IF NECESSARY, ADD SUITABLE REINFORCEMENTS TO THE ANCHORING POINTS
- DO NOT INSTALL DOOR OR GATE LEAVES ON TILTED SURFACES
- MAKE SURE ANY SPRINKLER SYSTEMS CANNOT WET THE OPERATOR FROM THE GROUND UP
- MAKE SURE THE TEMPERATURE RANGE SHOWN ON THE PRODUCT LITERATURE IS SUITABLE TO THE CLIMATE WHERE IT WILL BE INSTALLED
- FOLLOW ALL INSTRUCTIONS AS IMPROPER INSTALLATION MAY RESULT IN SERIOUS BODILY INJURY
- IT IS IMPORTANT TO FOLLOW THESE INSTRUCTIONS FOR THE SAFETY OF PEOPLE. KEEP THESE INSTRUCTIONS.

INSTALLING

- SUITABLY SECTION OFF AND DEMARCATATE THE ENTIRE INSTALLATION SITE TO PREVENT UNAUTHORIZED PERSONS FROM ENTERING THE AREA, ESPECIALLY MINORS AND CHILDREN
- BE CAREFUL WHEN HANDLING OPERATORS THAT WEIGH OVER 20 KG. IF NEED BE, USE PROPER SAFETY HOISTING EQUIPMENT
- ALL OPENING COMMANDS (THAT IS, BUTTONS, KEY SWITCHES, MAGNETIC READERS, AND SO ON) MUST BE INSTALLED AT LEAST 1.85 M FROM THE PERIMETER OF THE GATE'S WORKING AREA, OR WHERE THEY CANNOT BE REACHED FROM OUTSIDE THE GATE. ALSO, ANY DIRECT COMMANDS (BUTTONS, TOUCH PANELS, AND SO ON) MUST BE INSTALLED AT LEAST 1.5 M FROM THE GROUND AND MUST NOT BE REACHABLE BY UNAUTHORIZED PERSONS
- ALL MAINTAINED ACTION COMMANDS, MUST BE FITTED IN PLACES FROM WHICH THE MOVING GATE LEAVES AND TRANSIT AND DRIVING AREAS ARE VISIBLE
- APPLY, IF MISSING, A PERMANENT SIGN SHOWING THE POSITION OF THE RELEASE DEVICE
- BEFORE DELIVERING TO THE USERS, MAKE SURE THE SYSTEM IS EN 12453 STANDARD COMPLIANT (REGARDING IMPACT FORCES), AND ALSO MAKE SURE THE SYSTEM HAS BEEN PROPERLY ADJUSTED AND THAT ANY SAFETY, PROTECTION AND MANUAL RELEASE DEVICES ARE WORKING PROPERLY
- APPLY WARNING SIGNS (SUCH AS THE GATE'S PLATE) WHERE NECESSARY AND IN A VISIBLE PLACE

SPECIAL USER-INSTRUCTIONS AND RECOMMENDATIONS

- KEEP GATE OPERATION AREAS CLEAN AND FREE OF ANY OBSTRUCTIONS. MAKE SURE THAT THE PHOTOCELLS ARE FREE OF ANY OVERGROWN VEGETATION AND THAT THE OPERATOR'S AREA OF OPERATION IS FREE OF ANY OBSTRUCTIONS
- DO NOT ALLOW CHILDREN TO PLAY WITH FIXED COMMANDS, OR TO LOITER IN THE GATE'S MANEUVERING AREA. KEEP ANY REMOTE CONTROL TRANSMITTERS OR ANY OTHER COMMAND DEVICE AWAY FROM CHILDREN, TO PREVENT THE OPERATOR FROM BEING ACCIDENTALLY ACTIVATED.
- THE APPARATUS MAY BE USED BY CHILDREN OF EIGHT YEARS AND ABOVE AND BY PHYSICALLY, MENTALLY AND SENSORIALLY CHALLENGED PEOPLE, OR EVEN ONES WITHOUT ANY EXPERIENCE, PROVIDED THIS HAPPENS UNDER CLOSE SUPERVISION OR ONCE THEY HAVE BEEN PROPERLY INSTRUCTED TO USE THE APPARATUS SAFELY AND ABOUT THE POTENTIAL HAZARDS INVOLVED. CHILDREN MUST NOT PLAY WITH THE APPARATUS. CLEANING AND MAINTENANCE BY USERS MUST NOT BE DONE BY CHILDREN, UNLESS PROPERLY SUPERVISED
- FREQUENTLY CHECK THE SYSTEM FOR ANY MALFUNCTIONS OR SIGNS OF WEAR AND TEAR OR DAMAGE TO THE MOVING STRUCTURES, TO THE COMPONENT PARTS, ALL ANCHORING POINTS, INCLUDING CABLES AND ANY ACCESSIBLE CONNECTIONS. KEEP ANY HINGES, MOVING JOINTS AND SLIDE RAILS PROPERLY LUBRICATED
- PERFORM FUNCTIONAL CHECKS ON THE PHOTOCELLS AND SENSITIVE SAFETY EDGES, EVERY SIX MONTHS. TO CHECK WHETHER THE PHOTOCELLS ARE WORKING, WAVE AN OBJECT IN FRONT OF THEM WHILE THE GATE IS CLOSING; IF THE OPERATOR INVERTS ITS DIRECTION OF TRAVEL OR SUDDENLY STOPS, THE PHOTOCELLS ARE WORKING PROPERLY. THIS IS THE ONLY MAINTENANCE OPERATION TO DO WITH THE POWER ON. CONSTANTLY CLEAN THE PHOTOCELLS' GLASS COVERS USING A SLIGHTLY WATER-MOISTENED CLOTH; DO NOT USE ANY SOLVENTS OR OTHER CHEMICAL PRODUCTS THAT MAY RUIN THE DEVICES
- IF REPAIRS OR MODIFICATIONS ARE REQUIRED TO THE SYSTEM, RELEASE THE OPERATOR AND DO NOT USE IT UNTIL SAFETY CONDITIONS HAVE BEEN RESTORED
- CUT OFF THE POWER SUPPLY BEFORE RELEASING THE OPERATOR FOR MANUAL OPENINGS AND BEFORE ANY OTHER OPERATION, TO

PREVENT POTENTIALLY HAZARDOUS SITUATIONS. READ THE INSTRUCTIONS

- IF THE POWER SUPPLY CABLE IS DAMAGED, IT MUST BE REPLACED BY THE MANUFACTURER OR AUTHORIZED TECHNICAL ASSISTANCE SERVICE, OR IN ANY CASE, BY SIMILARLY QUALIFIED PERSONS, TO PREVENT ANY RISK
- IT IS FORBIDDEN FOR USERS TO PERFORM ANY OPERATIONS THAT ARE NOT EXPRESSLY REQUIRED OF THEM AND WHICH ARE NOT LISTED IN THE MANUALS. FOR ANY REPAIRS, MODIFICATIONS AND ADJUSTMENTS AND FOR EXTRAORDINARY MAINTENANCE, CALL TECHNICAL ASSISTANCE
- LOG THE JOB AND CHECKS INTO THE PERIODIC MAINTENANCE LOG.

ADDITIONAL SPECIAL RECOMMENDATIONS FOR EVERYONE

- KEEP AWAY FROM HINGES AND MECHANICAL MOVING PARTS
- DO NOT ENTER THE OPERATOR'S AREA OF OPERATION WHEN IT IS MOVING
- DO NOT COUNTER THE OPERATOR'S MOVEMENT AS THIS COULD RESULT IN DANGEROUS SITUATIONS
- ALWAYS PAY SPECIAL ATTENTION TO ANY DANGEROUS POINTS, WHICH HAVE TO BE LABELED WITH SPECIFIC PICTOGRAMS AND/OR BLACK AND YELLOW STRIPES
- WHILE USING A SELECTOR SWITCH OR A COMMAND IN MAINTAINED ACTIONS, KEEP CHECKING THAT THERE ARE NO PERSONS WITHIN THE OPERATING RANGE OF ANY MOVING PARTS, UNTIL THE COMMAND IS RELEASED
- THE GATE MAY MOVE AT ANY TIME AND WITHOUT WARNING
- ALWAYS CUT OFF THE POWER SUPPLY BEFORE PERFORMING ANY MAINTENANCE OR CLEANING.

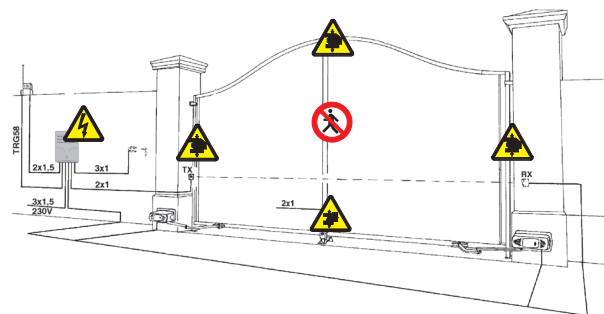

Danger of foot crushing



Danger of hand crushing



Danger! High voltage.



No transiting while the barrier is moving

Legend of symbols



This symbol tells you to read the section with particular care.



This symbol tells you that the sections concern safety issues.



This symbol tells you what to say to the end-users.

Intended use and restrictions

Intended use



The FERNI 230V operator is specifically engineered to automate residential and condominium swing gates.

The use of this product for purposes other than those described above and installation executed in a manner other than as instructed in this technical manual are prohibited.

Restrictions

Length of gate wings: up to 4 metres. Max. angle of gate wing when open: 90°.

Gate leaf width m	Gate leaf weight kg
2.00	800
2.50	600
3.00	500
3.50	450
4.00	400

For swing gates, installing an electric lock is always recommended. This is to ensure the leaves close reliably and to protect the gearmotor parts.

- It is also recommended for irreversible gearmotors – and is mandatory where the leaves are more than 2.5 m in length.
- For reversible gearmotors, electric locks are required to ensure the leaves close. The installer is responsible for installing an electric lock, taking into account the size and type of leaf (e.g. panelled) and the installation area (e.g. windy location).

Description

Gearmotor

This product is engineered and manufactured by CAME S.p.A. and complies with current safety regulations.

The gearmotor is composed of two, cast aluminium half shells inside of which rest the gearmotor and endstops – with electro blocking – and an endless screw, epicycloidal gear reduction system.

Technical features

Version F1000

Irreversible gearmotor
Motor power supply: 230V a.c. 50/60Hz
Max draw: 1,3A
Power: 360W
Gear ratio: 1/709
Opening time (90°): 18 s
Max. torque: 320 Nm
Duty Cycle: 30%
Protection Rating: IP54
Weight: 14 kg
Operating temperature

Version F1100

Reversible gearmotor
Motor power supply: 230V a.c. 50/60Hz
Max draw: 1A
Power: 230W
Gear ratio: 1/678
Opening time (90°): 18 s
Max. torque: 380 Nm
Duty Cycle: 50%
Protection Rating: IP54
Weight: 13 kg
Operating temperature

Description of parts

- 1) Base plate
- 2) Gearmotor assembly
- 3) Motor cover
- 4) Articulated transmission arm

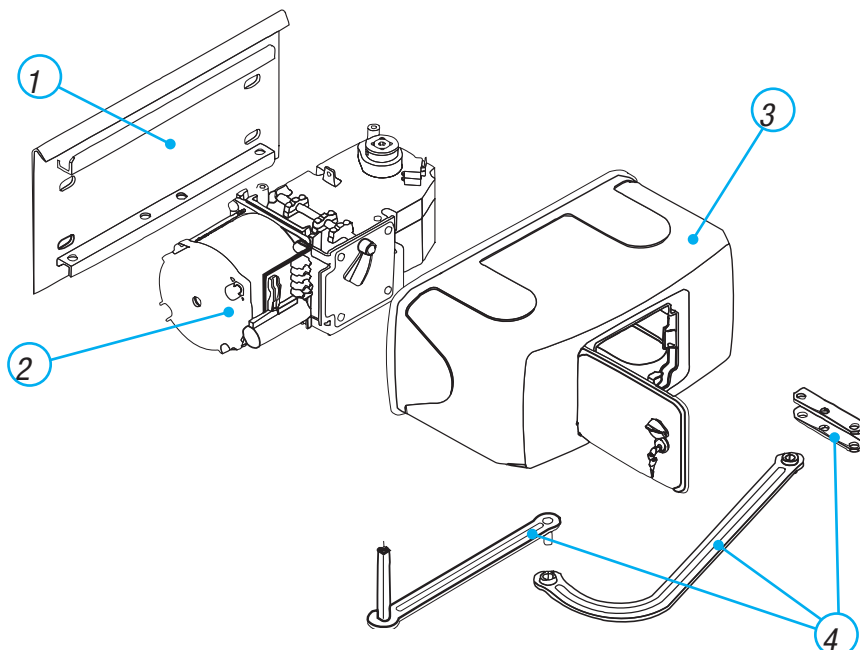

Optional accessory :

F1001 Straight telescopic arm (for single gate wings that are 0,5 to 2 m max long).

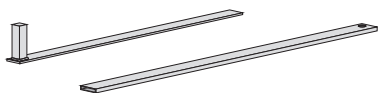

Overall dimensions

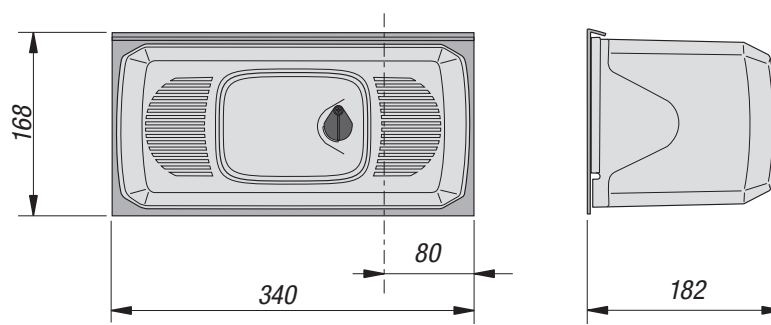

Installation

- Installation must be carried out by expert qualified personnel and in full compliance with current regulations.

Preliminary checks

- Before installing, do the following:
 - Make sure the structure of the gate is sturdy, the hinges work and that there is no friction between moving and non-moving parts;
 - Make sure the path of the electrical cables complies with the command and safety instructions;
 - That there is a (soundly secured to the ground) mechanical stop to prevent the gate leaf/gearmotor from over extending
- ⊕ You may perform internal back up circuit connections, provided you use additional insulation when compared to the other internal live parts;
- Make sure you have suitable tubing and conduits for the electrical cables to pass through and be protected against mechanical damage.

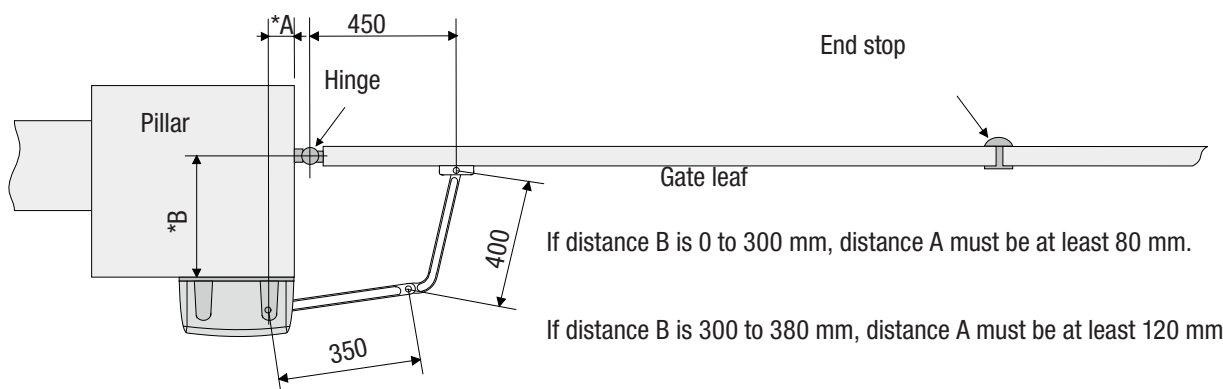

Tools and materials

Make sure you have all the tools and materials you will need for the installation at hand to work in total safety and compliance with the current standards and regulations. The following figure illustrates the minimum equipment needed by the installer.

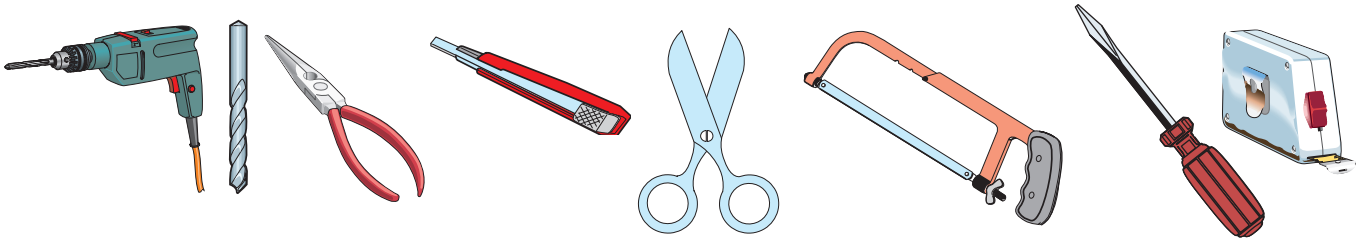

Cable list and minimum thickness

Connection	Type of cable	Cable length 1 < 10 m	Cable length 10 < 20 m	Cable length 20 < 30 m
230 V control panel power supply	FROR CEI 20-22 CEI EN 50267-2-1	3G x 1.5 mm ²	3G x 1.5 mm ²	3G x 2.5 mm ²
230 V motor power supply		3G x 1.5 mm ²	3G x 1.5 mm ²	3G x 2.5 mm ²
Flashing light		2 x 1.5 mm ²	2 x 1.5 mm ²	2 x 1.5 mm ²
Photocell transmitters		2 x 0.5 mm ²	2 x 0.5 mm ²	2 x 0.5 mm ²
Photocell receivers		4 x 1.5 mm ²	4 x 1.5 mm ²	4 x 1.5 mm ²
Accessories power supply		2 x 0.5 mm ²	2 x 0.5 mm ²	2 x 1 mm ²
Command and safety devices		2 x 0.5 mm ²	2 x 0.5 mm ²	2 x 0.5 mm ²
Antenna connection	RG58	max. 10 m		

N.B.: If the cable length differs from that specified in the table, then you must determine the proper cable diameter in the basis of the actual power drawn by the connected devices and depending on the standards specified in CEI EN 60204-1. For connections that require several, sequential loads, the sizes given on the table must be re-evaluated based on actual power draw and distances. When connecting products that are not specified in this manual, please follow the documentation provided with said products.

Standard installation

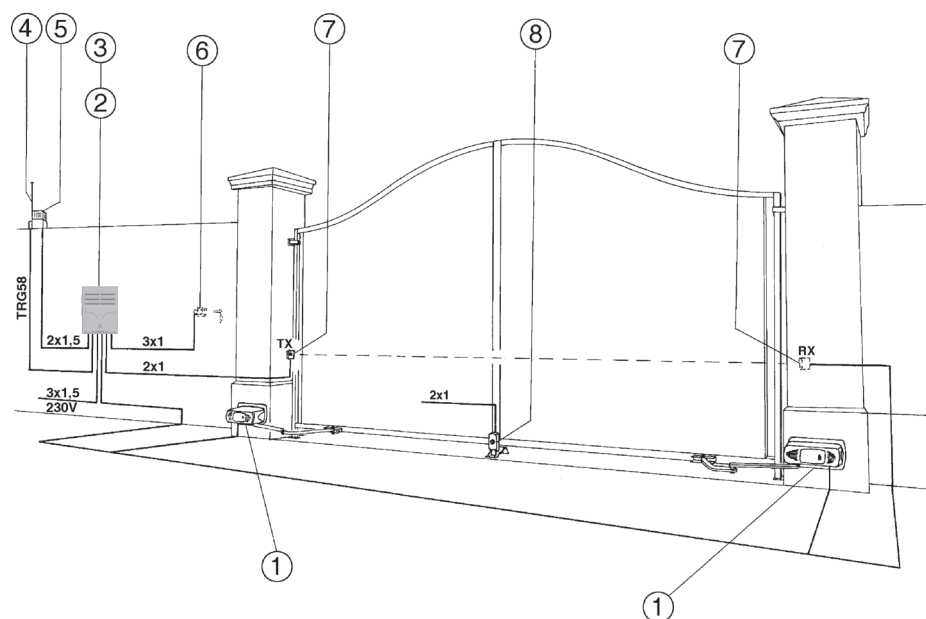

- 1 - Operator
- 2 - Control panel
- 3 - Radio receiver
- 4 - Antenna

- 5 - Flashing light
- 6 - Selector switch
- 7 - Photocells
- 8 - Electric lock

Mounting

- Secure the base plate to the pillar using $\varnothing 8$ screws and $\varnothing 14$ moulded inserts making sure the minimum distance of 150mm from the ground is met.
- Secure the A bracket (using $\varnothing 8$ screws or by welding) to the gate leaf making sure the 450mm and 19mm distances measurements and are met.

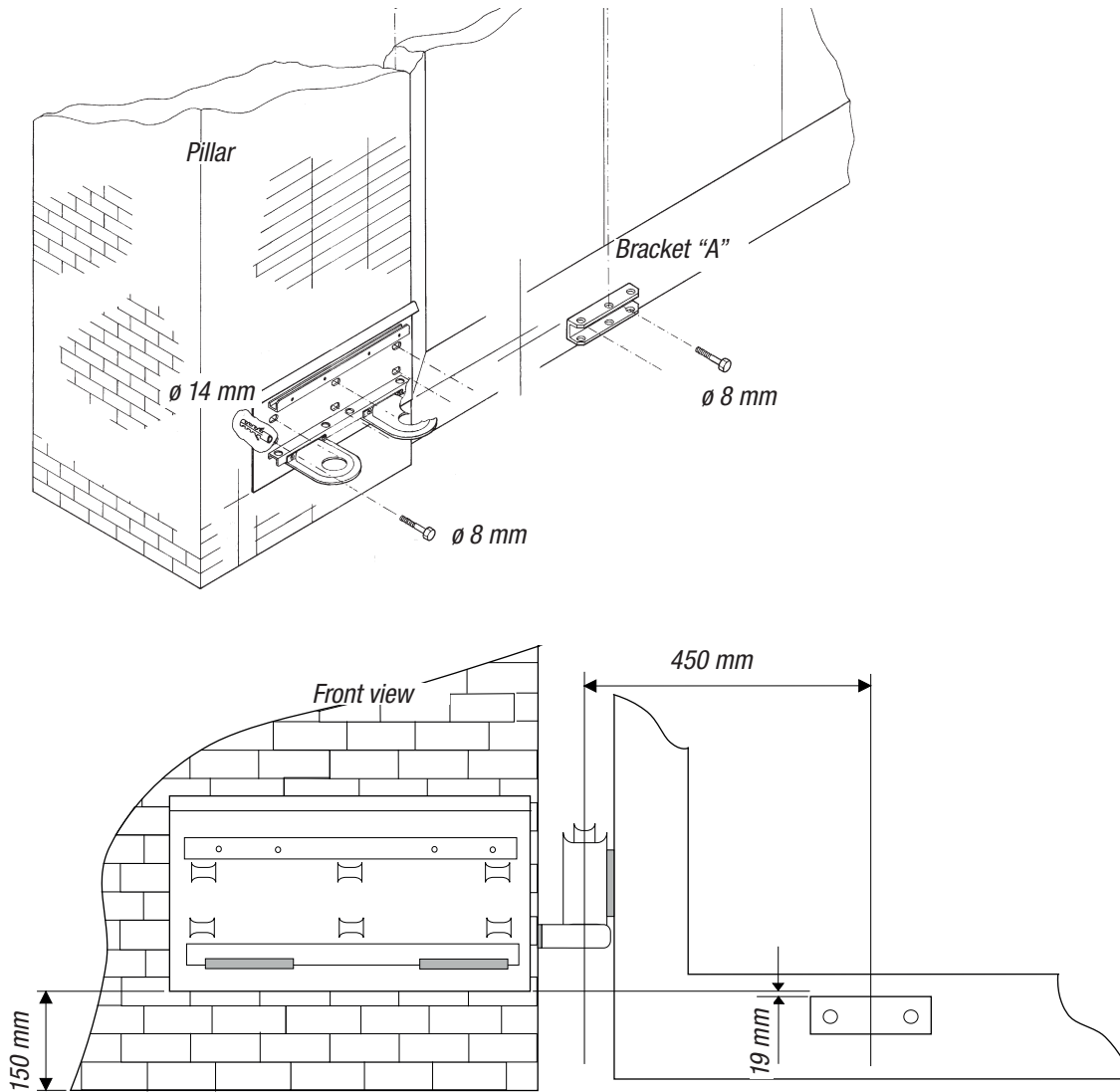

- Insert the gearmotor into the base plate and secure it using the two supplied M8x110 screws and M8 nuts.

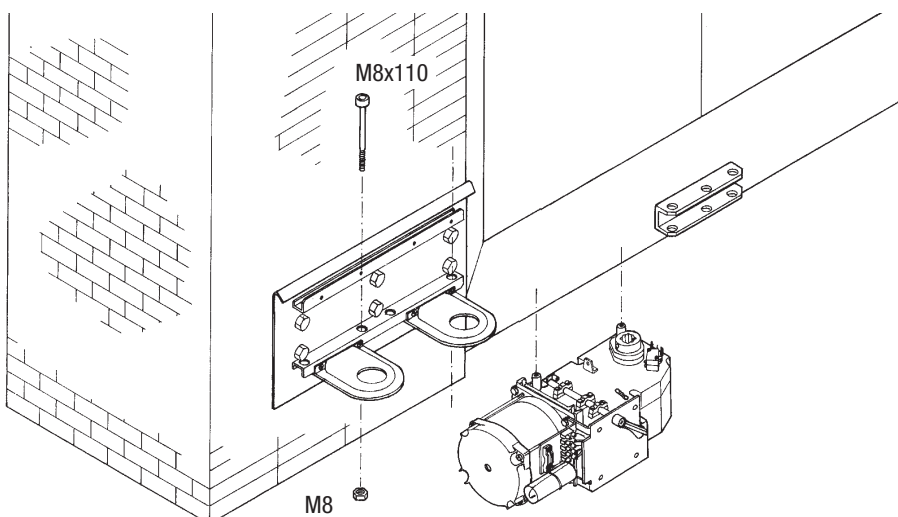

- Insert the straight semi-arm into the motor shaft. Apply the flared washer, the M6x20 screw and lock the semi-arm using the two grub screws.

Join and secure the two arms using the washer and M8x16 screw. Release the motor (see p. 7) and secure the curved semi-arm to the "A" bracket using the M12X50 screw and the M12 nut making sure it runs freely. For right-hand application see fig. 2.

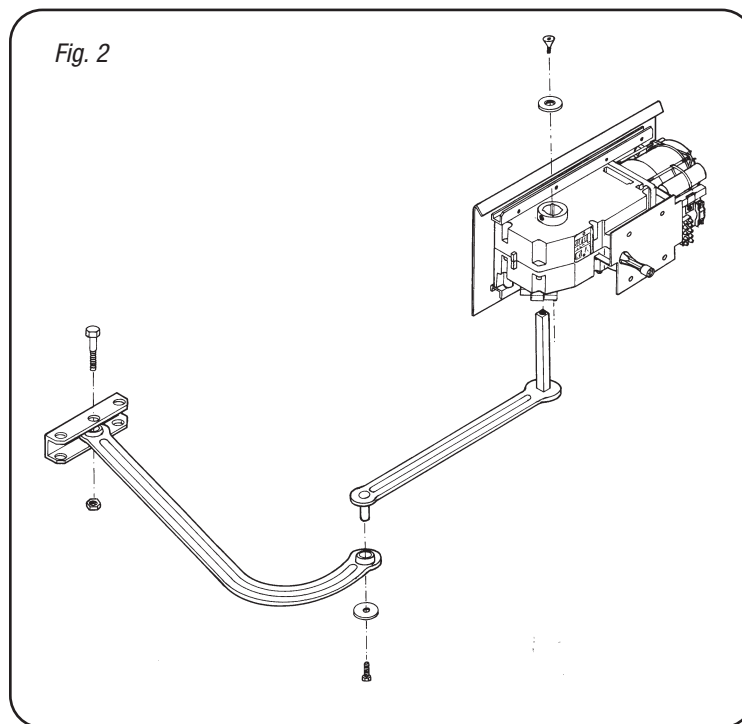
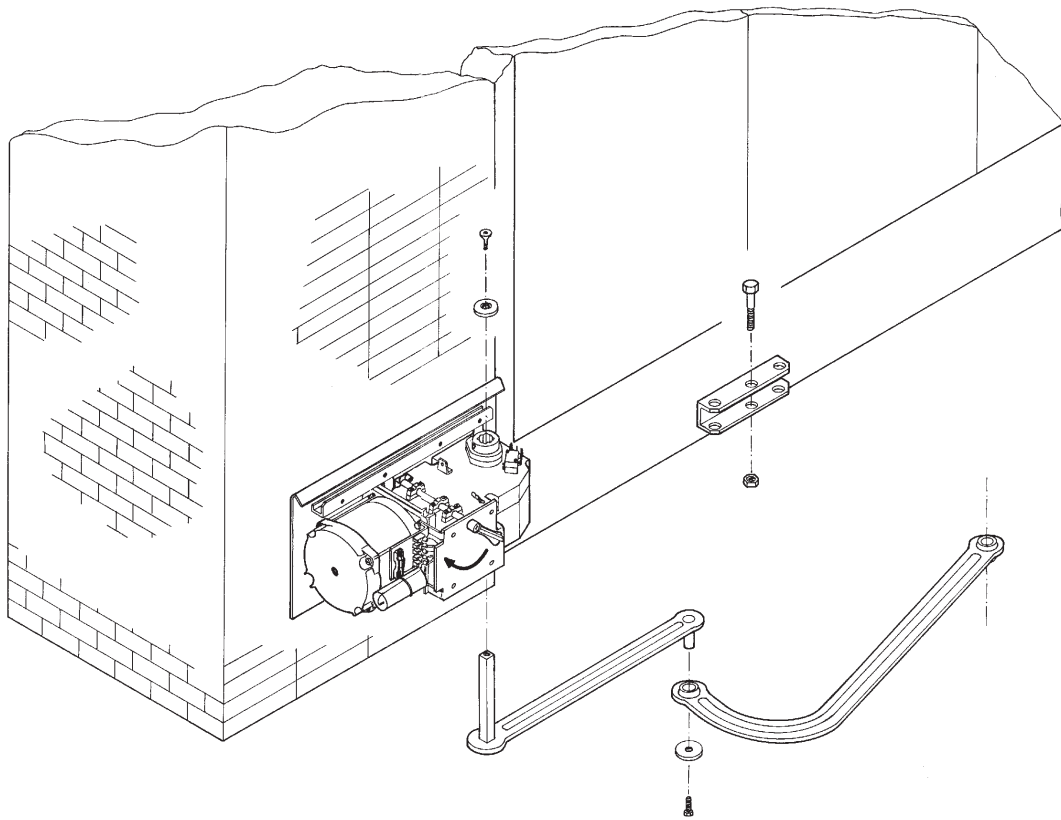

Adjusting the closing and opening-speed brake microswitches

During opening: release and move the door to the open position desired. Turn the upper cam until the microswitch is activated and screw the microswitch is activated and screw the screw in the related cam.

During closure (F 1000 only): release the door and move it to the desired closing position. Turn the lower cam until the microswitch is activated and screw the screw in the related cam.

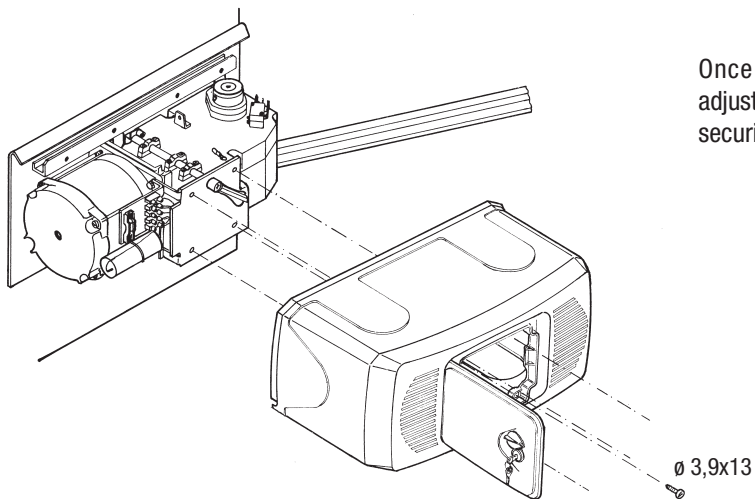
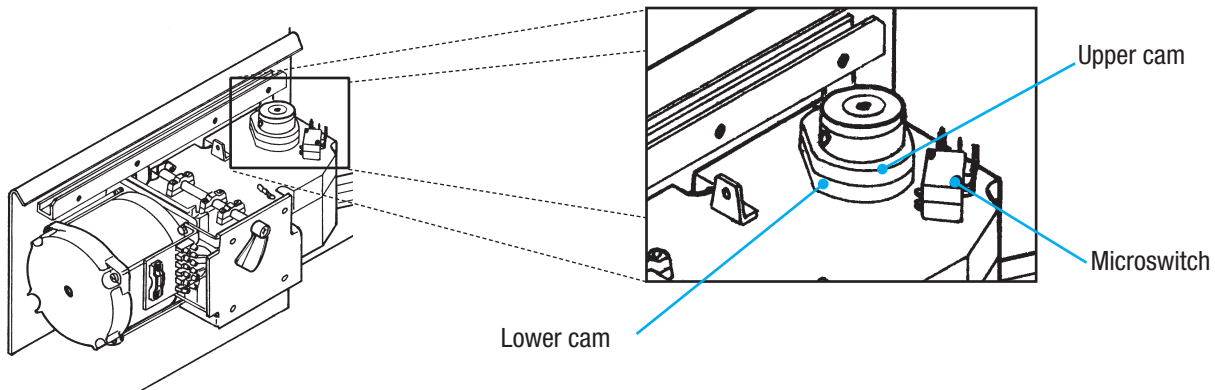

Once finished with mounting, electrical connections and adjustments, lock the motor back into place and replace the cover securing it with the 4 issued screws.

Manually releasing the motor

Carry out when motor is not in operation

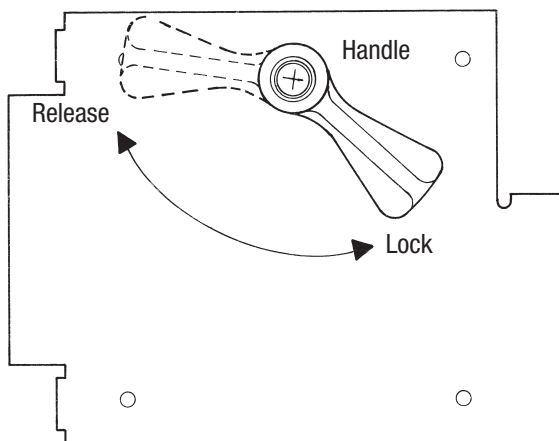

In the event of power outages or breakdowns, release the gearmotor using the apposite handle.

Connecting to the ZA3N/ZF1N/ZM3E control panel

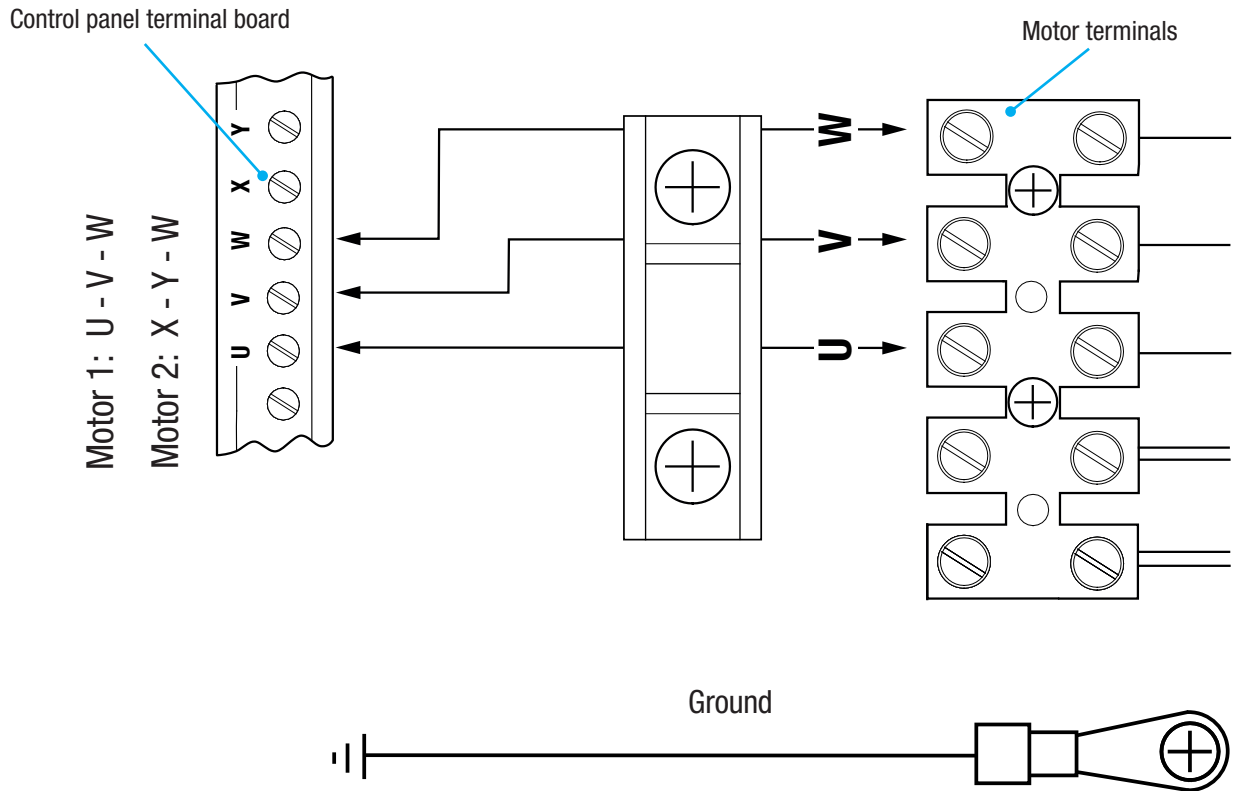

☞ If only using one motor, such as with one-leaf gates, connect it to W X Y (M2) regardless of which side it is installed on.

INSTALLING AND CONNECTIONS FOR OUTWARD-OPENINGS

Below are the only procedures that vary compared to standard installations:

Securing the brackets

N.B. the drawings refer to installation of the left-hand gearmotor. The installation of the right-hand gearmotor is symmetrical. Determine the fixing point for the gate bracket and calculate the fixing point of the pillar bracket, respecting the values shown in the drawings and table.

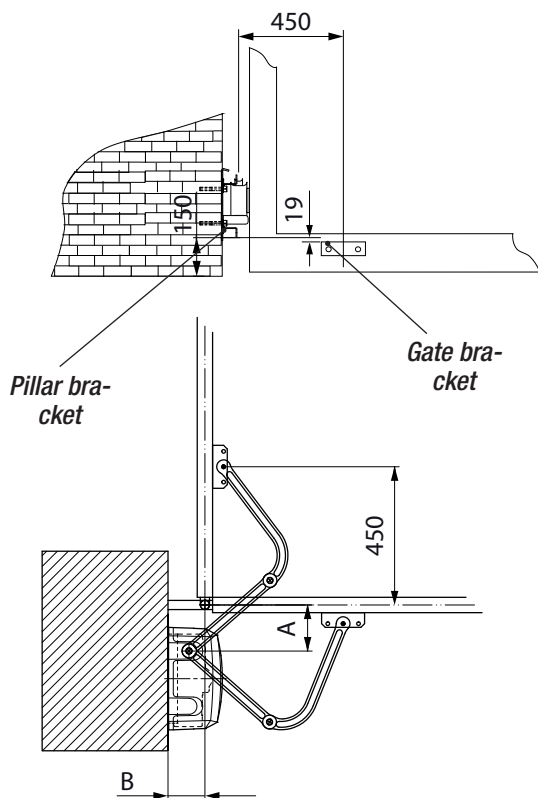

Application size

Leaf opening	A	B
90°	150	0 ÷ 120
120°	150	0 ÷ 60

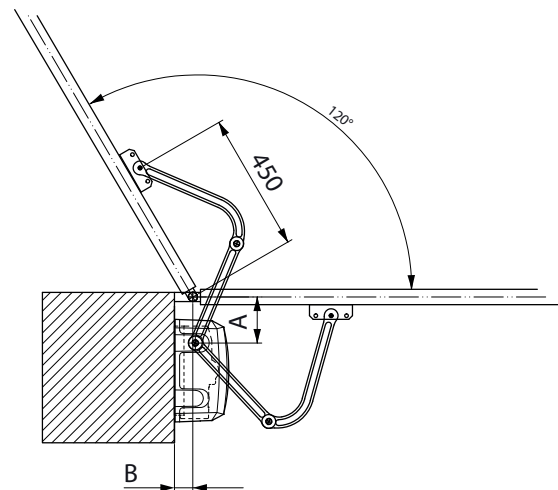

Electrical connections

For electrical connection operations, use the chamber and the junction boxes.

For further information regarding functions and adjustment, refer to the technical documentation for the control panel.

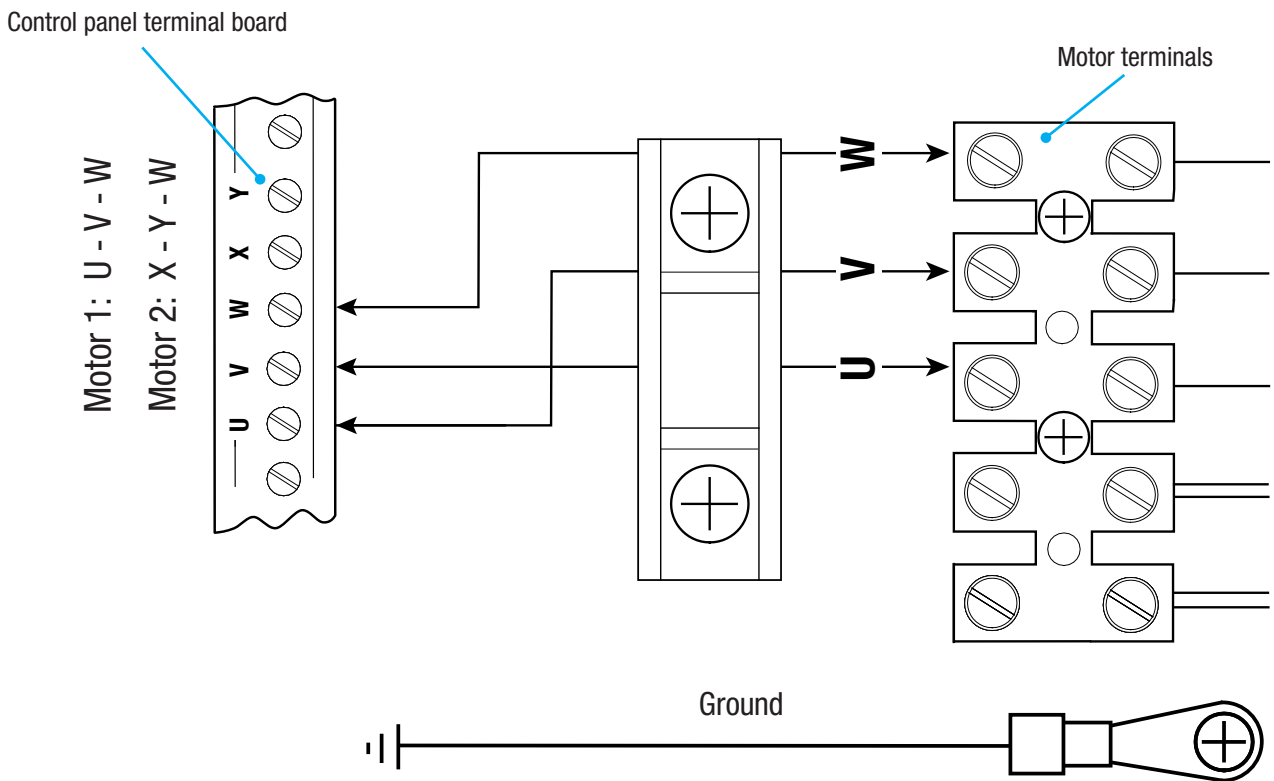

☞ If only using one motor, such as with one-leaf gates, connect it to W X Y (M2) regardless of which side it is installed on.

Maintenance

Periodic maintenance

☞ Before doing any maintenance, cut off the power supply, to prevent any hazardous situations caused by accidentally activating the operator.

Periodic maintenance log kept by users (every six months)

Date	Notes	Signature

Extraordinary maintenance

△ The following table is for logging any extraordinary maintenance jobs, repairs and improvements performed by specialized contractors.

📖 Any extraordinary maintenance jobs must be done only by specialized technicians.

Extraordinary maintenance log

Installer's stamp	Name of operator
	Job performed on (date)
	Technician's signature
	Requester's signature
Job performed _____ _____ _____	

Installer's stamp	Name of operator
	Job performed on (date)
	Technician's signature
	Requester's signature
Job performed _____ _____ _____	

Installer's stamp	Name of operator
	Job performed on (date)
	Technician's signature
	Requester's signature
Job performed _____ _____ _____	

Installer's stamp	Name of operator
	Job performed on (date)
	Technician's signature
	Requester's signature
Job performed _____ _____ _____	

Trouble shooting

MALFUNCTIONS	POSSIBLE CAUSES	CHECK AND REMEDIES
The gate will not open nor close	<ul style="list-style-type: none"> • There is no power • The gearmotor is released • The transmitter's batteries are run down • The transmitter is broken • The stop button is either stuck or broken • The opening/closing button or the keyswitch are stuck 	<ul style="list-style-type: none"> • Check that the power is up • Lock gearmotor (Chapt. 5.8) • Replace batteries • Call assistance • Call assistance • Call assistance
The gate opens but will not close	<ul style="list-style-type: none"> • The photocells are engaged 	<ul style="list-style-type: none"> • Check that photocells are clean and in good working order • Call assistance
The flashing light does not work	<ul style="list-style-type: none"> • The bulb is burnt 	<ul style="list-style-type: none"> • Call assistance

Demolition and disposal

 CAME S.p.A. employs a UNI EN ISO 14001 certified and compliant environmental protection system at its plants, to ensure that environmental safeguarding.

We ask you to keep protecting the environment, as CAME deems it to be one of the fundamental points of its market operations strategies, by simply following these brief guidelines when disposing:

DISPOSING THE PACKING MATERIALS

The packing components (cardboard, plastic, etc.) are solid urban waste and may be disposed of without any particular difficulty, by simply separating them so that they can be recycled.

Before actions it is always advisable to check the pertinent legislation where installation will take place.

DO NOT DISPOSE OF IN NATURE!

DISPOSING OF THE PRODUCT

Our products are made using different types of materials. The majority of them (aluminium, plastic, iron, electric cables) can be considered to be solid urban waste. They may be recycled at authorised firms.

Other components (electrical circuit board, remote control batteries etc.) may contain hazardous waste.

They must, thus, be removed and turned in to licensed firms for their disposal.

Before acting always check the local laws on the matter.

DO NOT DISPOSE OF IN NATURE!

Reference regulations

The product complies to the reference regulations in effect.

CAME 

CAME.COM

CAME S.P.A.

Via Martiri Della Libertà, 15

31030 Dosson di Casier - Treviso - Italy

tel. (+39) 0422 4940 - fax. (+39) 0422 4941