



CE

119BU30EN

AUTOMATION SYSTEMS
FOR SLIDING GATES

Official Partner



MILANO 2015

FEEDING THE PLANET
ENERGY FOR LIFE



INSTALLATION MANUAL

BX-243



English

EN



CAUTION!
important personal safety instructions:
READ CAREFULLY!



ENGLISH

Foreword

• This product should only be used for the purpose for which it was explicitly designed. Any other use is considered dangerous. CAME Cancelli Automatici S.p.A. is not liable for any damage resulting from improper, wrongful or unreasonable use • Keep these warnings with the installation and use manuals issued with the automation system.

Before installing

(preliminary check: in case of a negative outcome, do not proceed until you have complied with the safety requirements)

• Check that the part you intend to automate is in good mechanical condition, balanced and aligned, and that it opens and closes properly. Make sure that proper mechanical stops are already in place • If the operator will be installed at a height of less than 2.5 m from the ground or other access level, check whether you will need any protections and/or warnings • Any leaves fitted with pedestrian entrances onto which you will install an operator must have a blocking mechanism when the leaf is in motion • Make sure that the opening of the automated leaf is not an entrapment hazard as regards any surrounding fixed parts • Do not mount the operator upside down or onto any elements that may fold under its weight. If needed, add suitable reinforcements at the points where it is secured • Do not install onto leaves not on level ground • Check that any lawn watering devices will not wet the operator from the bottom up.

Installation

• Carefully section off the entire site to prevent unauthorised access, especially by minors and children • Be careful when handling operators that weigh more than 20 kg. In case, procure the tools required for safe gate movement • All opening commands (buttons, key selectors, magnetic readers etc.) must be installed at least 1.85 m from the perimeter of the area of turnstile movement, or where they cannot be reached from outside through the turnstile. In addition, direct controls (button, touch sensitive keys, etc.) must be installed at a height of at least 1.5 m and must not be accessible to the public • All 'hold-to-run' commands must be placed where the moving gate leaves, transit areas and driveways are completely visible • If missing, apply a permanent label that shows the position of the release mechanism • Before delivering to the user, check that the system is EN 12453 (impact test) standard compliant. Make sure that the operator has been properly adjusted and that the safety and protection devices as well as the manual release are working properly • Where necessary and in plain sight, apply the Warning Signs (e.g. gate plate)

Special instructions and advice for users

• Keep the gate's area of operation clean and clear of any obstacles. Check that there is no vegetation in the area of operation of the photocells and that there are no obstacles in the area of operation of the operator • Do not allow children to play with the fixed command devices, or in the gate's area of operation. Keep any remote control devices (i.e. transmitters) or any control devices away from children as well, to prevent the operator from being activated accidentally • The operator is not designed to be used by persons (including children) whose physical, sensorial or mental capacities are limited, or who are lacking in experience or knowledge, unless said persons can be supervised or given instructions regarding using the operator by a person responsible for their safety • Frequently check the system, to see whether any anomalies or signs of wear and tear appear on the moving parts, on the component parts, on the securing points, on the cables and any accessible connections. Keep any joints (i.e. hinges) lubricated and clean, and do the same where friction may occur (i.e. slide rails) • Perform functional tests on photocells and sensitive edges every six months. To check that the photocells work, pass an object in front of them during closing. If the operator reverses the direction of movement or comes to a halt, the photocells work correctly. This is the only maintenance operation that must be carried out while the operator is live. Ensure that the glass on the photocells is kept clean (use a cloth slightly moistened with water; do not use solvents or any other chemicals as these could damage the devices) • If the system requires repairs or modifications, release the operator and do not use it until safety conditions have been restored • Cut

off the power supply before releasing the operator for manual openings and before any other operation, to prevent dangerous situations. Read the instructions • If the power cable is damaged, it must be replaced by the manufacturer or the technical assistance service or by a person with a similar qualification so as to prevent any risks • It is STRICTLY FORBIDDEN for users to perform OPERATIONS THEY ARE NOT EXPLICITLY REQUIRED AND ASKED to do in the manuals. For repairs, adjustments and extraordinary maintenance, CONTACT THE SPECIALIST TECHNICAL SERVICE CENTRE • On the periodic maintenance log, note down the checks you have done.

Special instructions and advice for all

• Avoid working near the hinges or moving mechanical parts • Stay clear of the gate's area of operation when in motion • Do not resist the direction of movement of the gate; this may present a safety hazard • At all times be extremely careful about dangerous points that must be indicated by proper pictograms and/or black and yellow stripes • When using a selector or command in 'hold-to-run' mode, keep checking that there are no people in the area of operation of the moving parts. Do this until you release the command • The gate may move at any time without warning • Always cut the power when cleaning or performing maintenance.

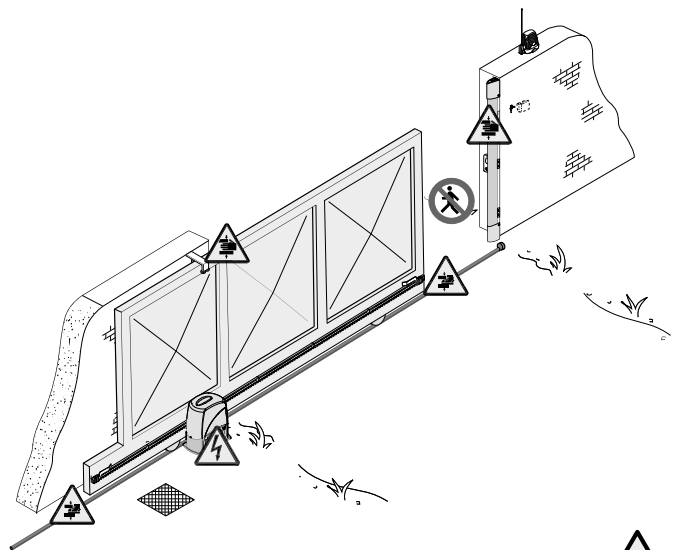

Danger of crushing feet



Danger of hand crushing



Danger - live parts



No transit during the manoeuvre



“IMPORTANT INSTALLATION, SAFETY INSTRUCTIONS”

“CAUTION: IMPROPER INSTALLATION MAY CAUSE SERIOUS DAMAGE, FOLLOW ALL INSTALLATION INSTRUCTIONS CAREFULLY”

“THIS MANUAL IS ONLY FOR PROFESSIONAL OR QUALIFIED INSTALLERS”



1 Legend of symbols



This symbol tells you to read the section with particular care.



This symbol tells you that the sections concern safety issues.



This symbol tells you what to say to the end-users.

2 Conditions of use

2.1 Intended use

The BX243 operator is designed to power sliding gates in residential and condominium settings.



Do not install or use unless as otherwise shown in this manual.

2.2 Limitations to use

For intensive or condominium use: max gate weight 300kg with max gate length 8,5 m.

3 Reference standards

The company CAME cancelli automatici is ISO 9001:2000 quality certified; it has also obtained the ISO 14001 environmental safeguarding certification. CAME engineers and manufactures all of its products in Italy.

This product complies with the following legislation: see declaration of compliance.

4 Description

4.1 Operator

This product is engineered and manufactured by CAME CANCELLI AUTOMATICI S.p.a. in compliance with current safety standards. The operator is made of a cast aluminium part inside of which operates the irreversible, electromechanical gearmotor and an ABS plastic lining which holds the electronic card, transformer and battery rack.

4.2 Technical features

BX243 OPERATOR

Control panel power supply: 230V A.C. 50/60Hz

Operator power supply: 24V D.C.

Draw: 7A max.

Power: 170W

Reduction ratio: 1/50

Thrust: 300N

Max speed.: 12m/min max.

Duty cycle: intensive use

Protection rating: IP54

Insulation class: I

Weight: 12kg

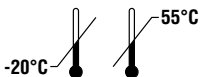

4.3 Description of parts

- 1) Top cover
- 2) Motor
- 3) Transformer
- 4) Trap door to access manual release of gearmotor
- 5) Securing plate
- 6) Securing bolt
- 7) Securing nut and washer
- 8) Protective cover for electronic card
- 9) ZN2 electronic card
- 10) Card and battery rack support

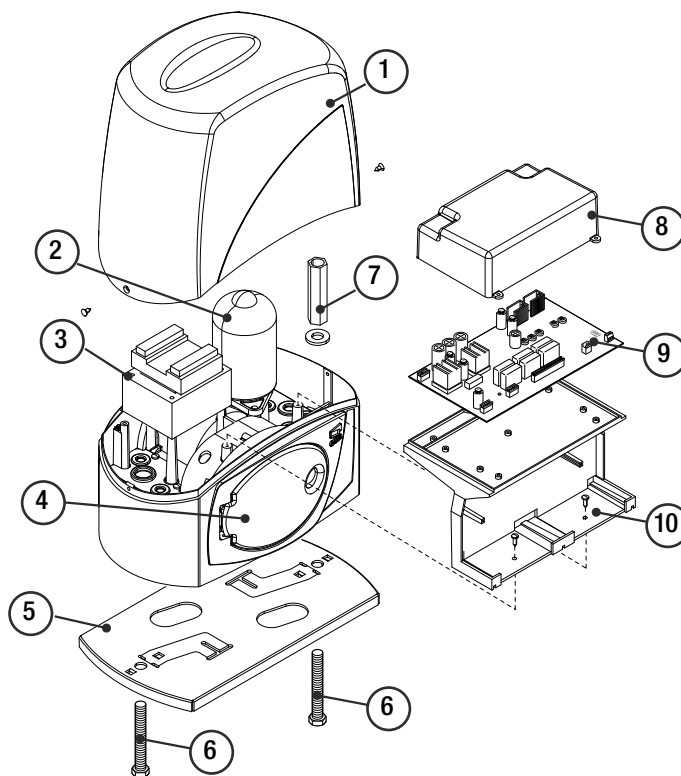

4.4 Dimensions

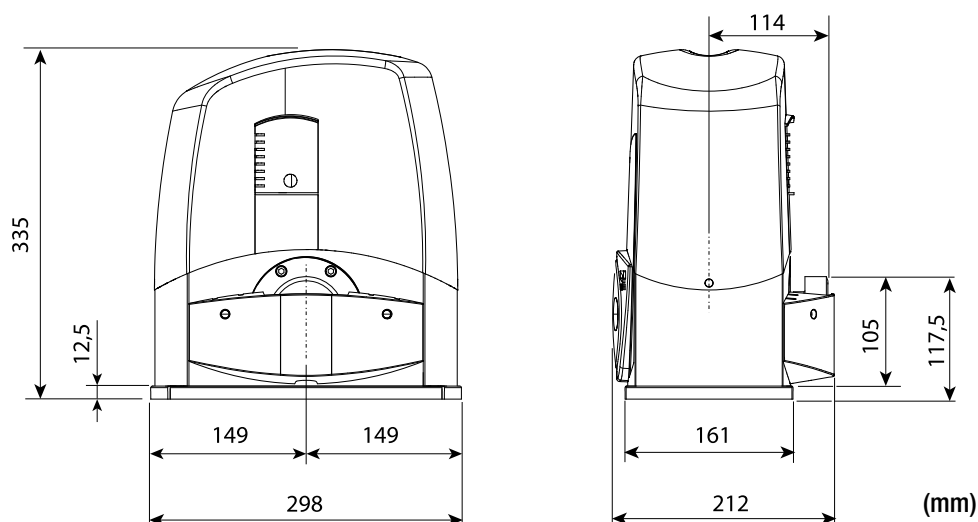

5 Installation

⚠ Installation must be carried out by expert qualified personnel and in full compliance with current regulations.

5.1 Preliminary checks

⚠ Before installing, do the following:

- Make sure that the gate is stable, and that the castors are in good working order and properly greased.
- The ground rack must be well secured to the ground, entirely above the surface and free of any irregularities that may obstruct the gate's movement.
- The upper guide rails must not create any friction.
- Make sure that there is a closing and an opening endstops.
- Make sure that the operator is attached to a solid surface and protected from any impacts;
- Make sure you have a suitable omnipolar cut-off device with contacts more than 3 mm apart, and independent (sectioned off) power supply;
- ⚡ Check that any connections inside the container (that provide continuity to the safety circuit) are fitted with additional insulation compared to other internal live parts;
- Make sure you have suitable tubing and conduits for the electrical cables to pass through and be protected against mechanical damage.

5.2 Tools and materials

Make sure you have all the tools and materials you will need for the installation at hand to work in total safety and compliance with the current standards and regulations. The following figure illustrates the minimum equipment needed by the installer.

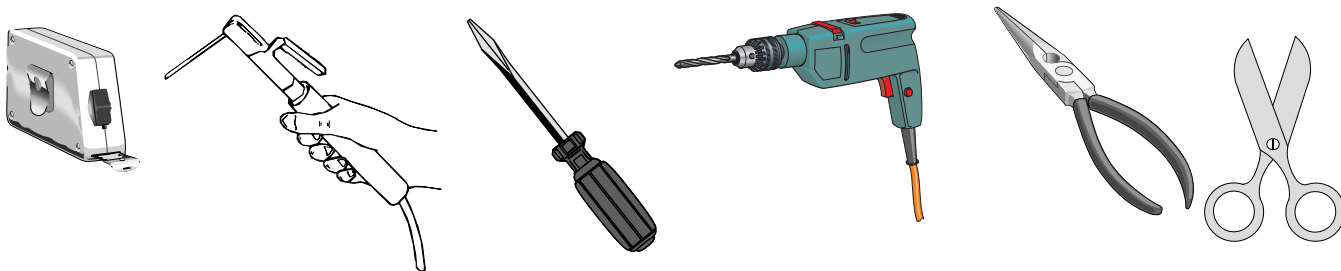

5.3 Cable list and minimum thickness

Connection	Type of cable	Length of cable 1 < 10 m	Length of cable 10 < 20 m	Length of cable 20 < 30 m
Control panel power supply 230V	FROR CEI 20-22 CEI EN 50267-2-1	3G x 1,5 mm ²	3G x 2,5 mm ²	3G x 4 mm ²
Flashing light		2 x 0,5 mm ²	2 x 1 mm ²	2 x 1,5 mm ²
Photocell transmitter		2 x 0,5 mm ²	2 x 0,5 mm ²	2 x 0,5 mm ²
Photocell receiver		4 x 0,5 mm ²	4 x 0,5 mm ²	4 x 0,5 mm ²
Accessories power supply		2 x 0,5 mm ²	2 x 0,5 mm ²	2 x 1 mm ²
Safety and control devices		2 x 0,5 mm ²	2 x 0,5 mm ²	2 x 0,5 mm ²
Antenna connection	RG58	max. 10 m		

N.B.: If the cable length differs from that specified in the table, then you must determine the proper cable diameter in the basis of the actual power draw by the connected devices and depending on the standards specified in CEI EN 60204-1.

For connections that require several, sequential loads, the sizes given on the table must be re-evaluated based on actual power draw and distances. When connecting products that are not specified in this manual, please follow the documentation provided with said products.

5.4 Standard installation

- 1) BX246 assembly
- 2) Rack
- 3) Reception Antenna
- 4) Flashing light
- 5) Keyswitch selector
- 6) Safety photocells
- 7) Electric cable junction box
- 8) Mechanical endstops
- 9) Guide rails
- 10) Endstop fins
- 11) Sensitive edge

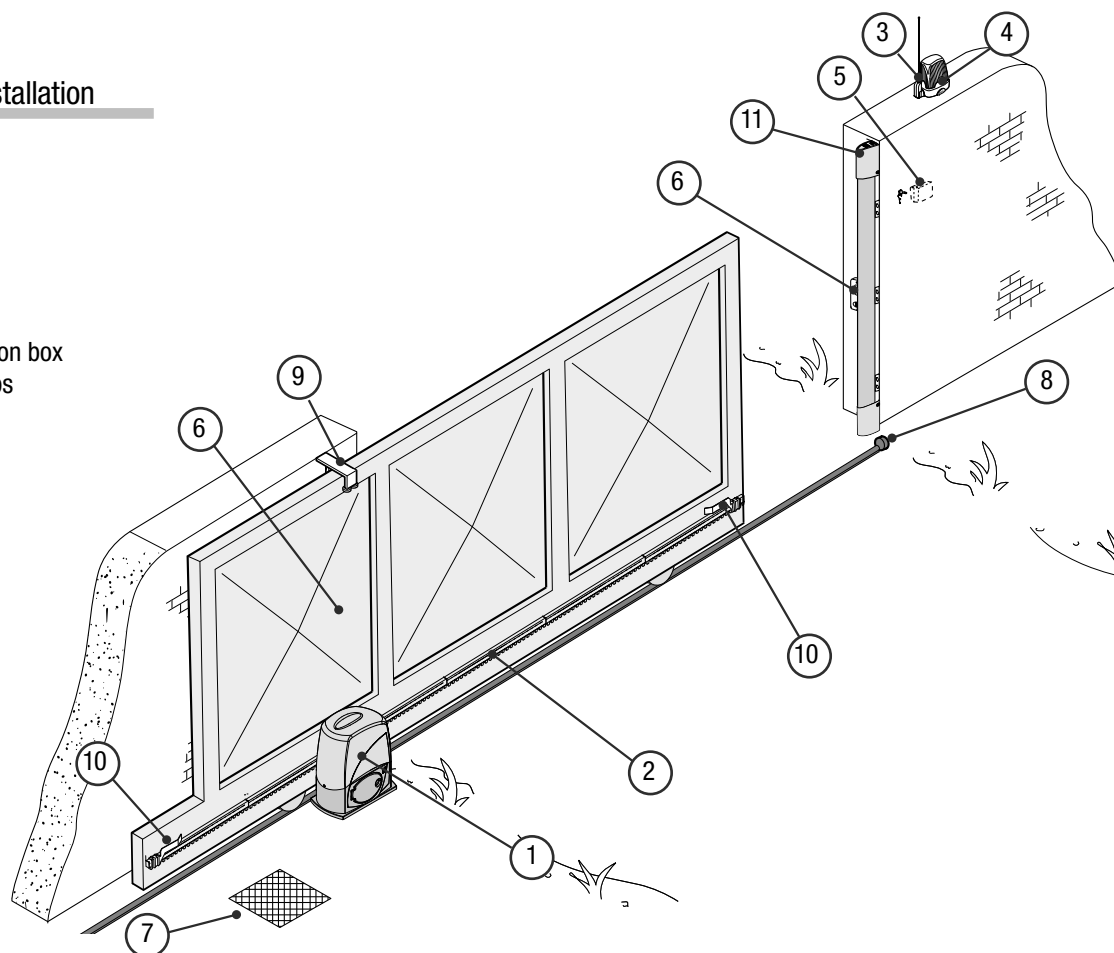

5.5 Securing the plate and installing the assembly

⚠ The following applications are only examples, as the space for installing the ratiomotor and accessories varies according to obstructions. It is thus up to the system installer to select the most suitable solution.

- Dig a pit to the side of the gate (see measurements from diagram).
- Prepare the corrugated tubes you will need when making connections coming from the shunt pit.
- N.B. the number of tubes depends on the type of system and the accessories you will hook up.

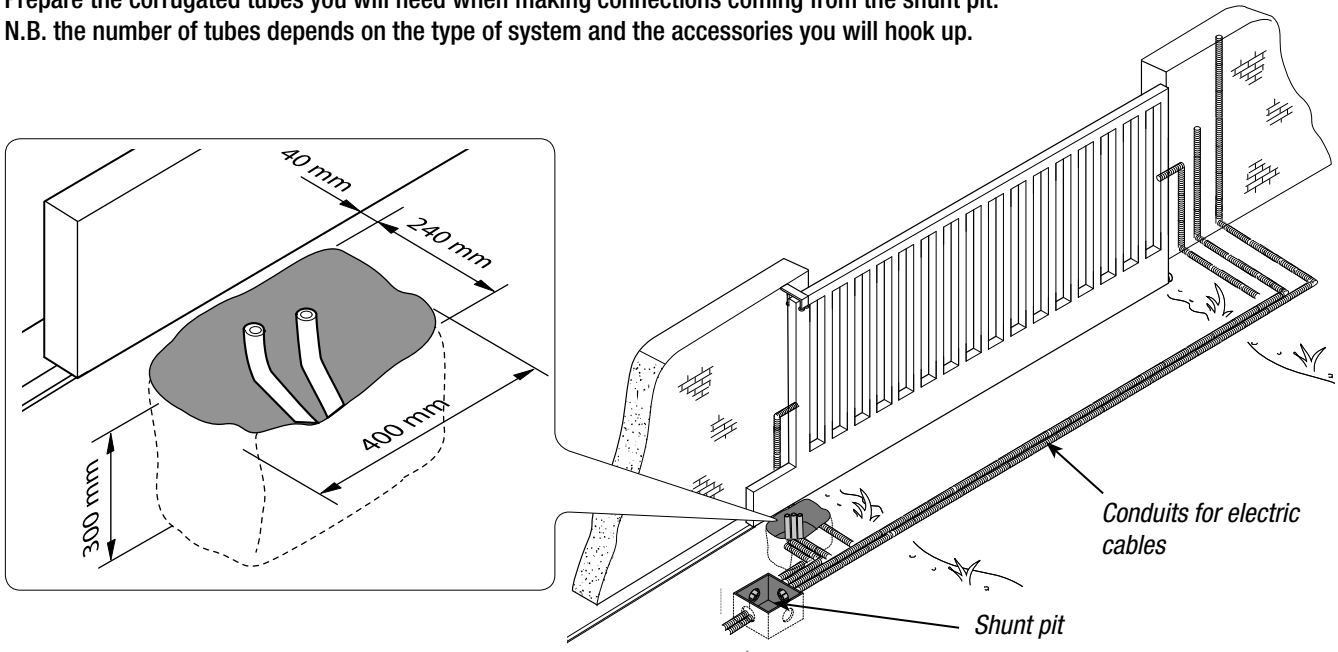

- Prepare a form box that is larger in size than the securing plate and insert it into the pit. The form box should jut 50mm above ground level.
- Insert an iron grid inside the form box to reinforce the concrete.
- Prepare the securing plate, insert the bolts into the holes and lock them using the supplied nuts and washers. Extract the preformed brackets using a screw driver or a set of pliers.

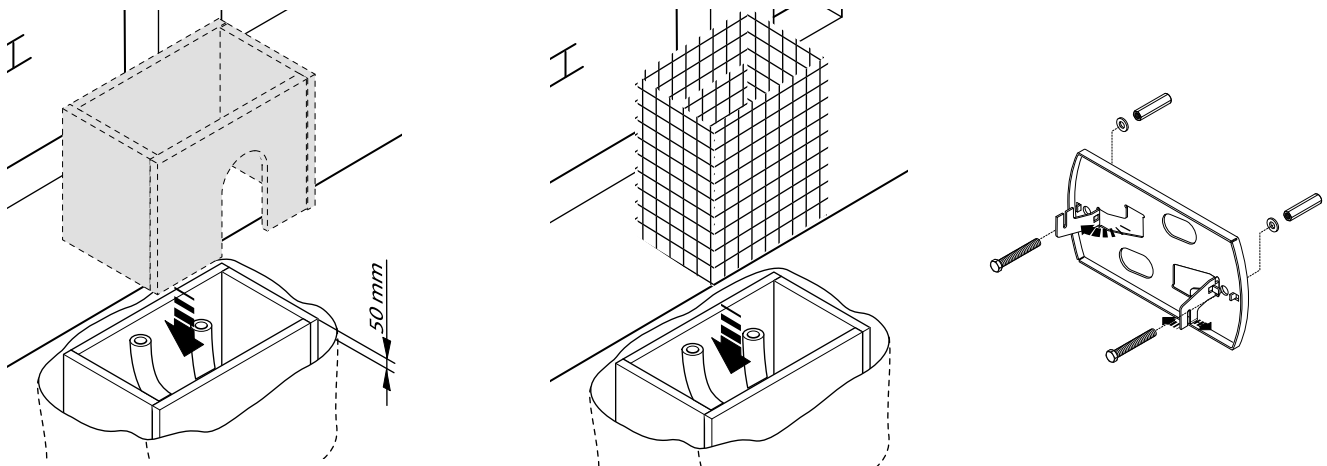

- Position the plate on top of the grid. Careful! The tubes need to pass through the opposite holes.
- To position the plate in relation to the rack please see the measurements on the diagram.
- Fill the form box with cement and wait for at least 24 hours for it to solidify.

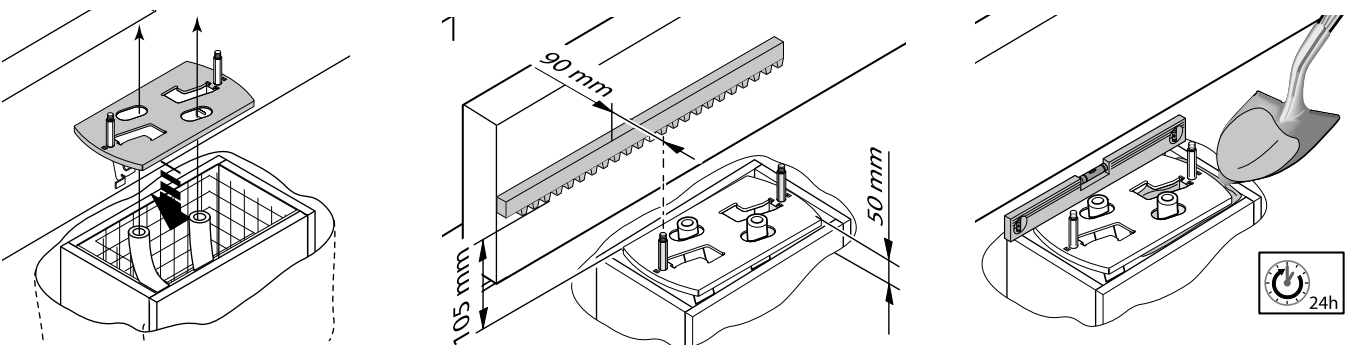

Remove the form box (1), fill the pit around the cement block with soil (2) and unbolt the nuts and washers from the bolts (3). The securing plate must be clean, perfectly aligned and with the bolt threads completely on the surface. Insert the electric cables into the tubes until they exit about 400mm (4).

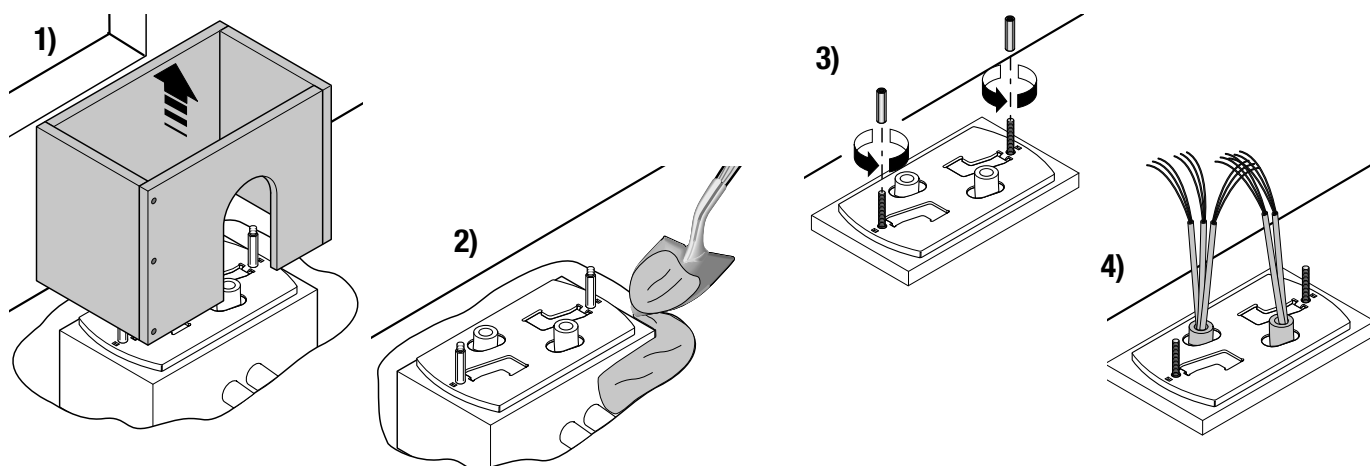

- Remove the cover from the gearmotor by loosening the side bolts, perforate the cable shafts using a screwdriver or a pair of scissors and position the gearmotor atop the plate. Careful! The electric cables must pass through the cable shafts.

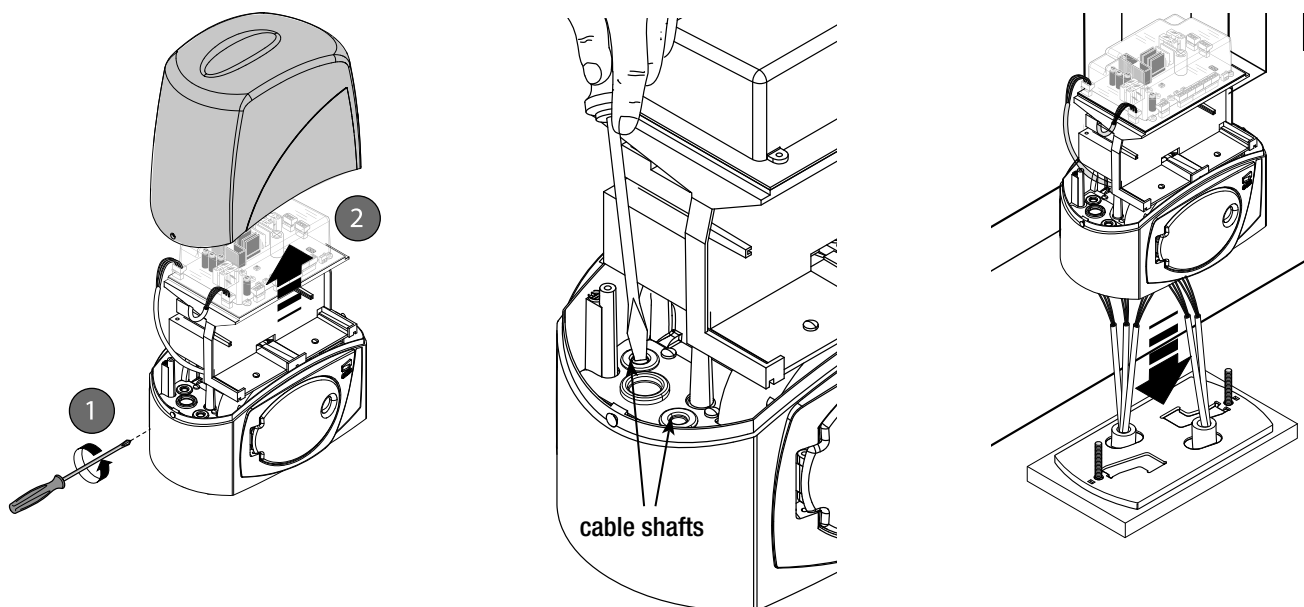

- Lift the gearmotor from the securing plate by about 5 to 10mm by using the threaded steel-levelling feet to allow any later adjustments between the pinion and the rack.

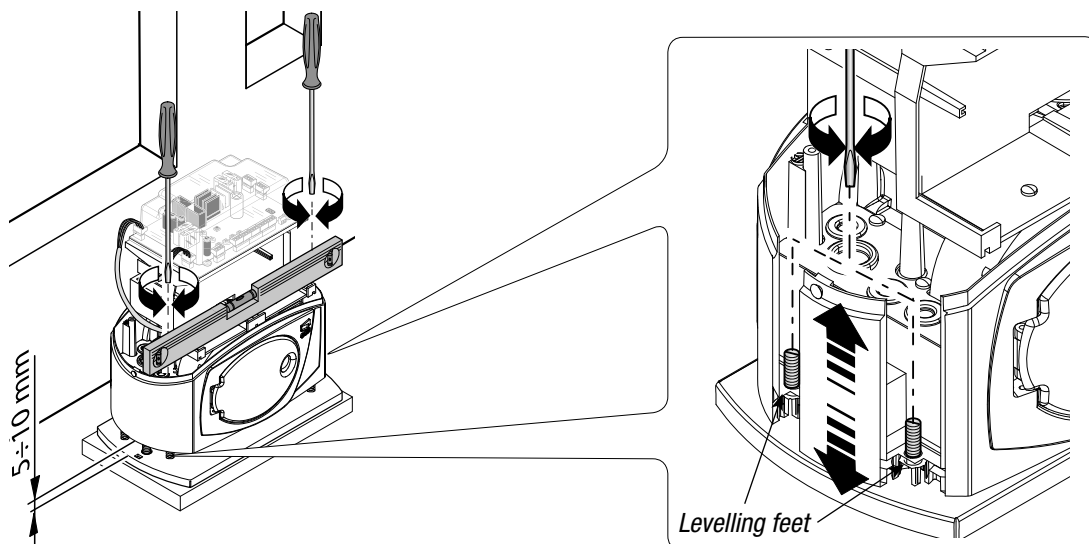

- The following illustrations for the securing the rack, are just examples of applications. It is up to the installer to choose the best solution.

Releasing the gearmotor (see paragraph on manual release). Rest the rack on the gearmotor pinion.

Weld or secure the rack to the gate along its entire length.

To assemble the rack modules, use an excess piece of rack and place it under the joining point, then block it using two C-clamps (3).

Note: if a rack is already in place, then just adjust the pinion-to-rack distance.

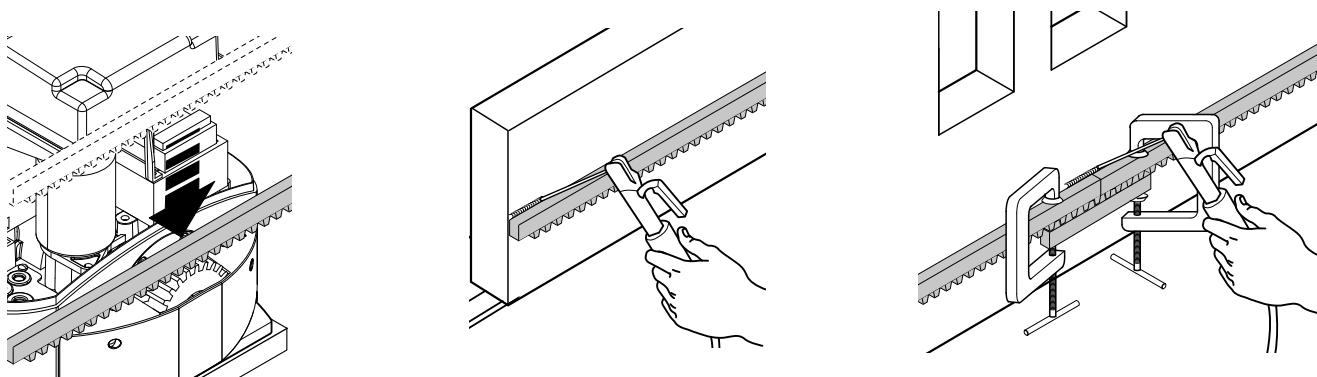

- Open and close the gate manually and register the pinion-to-rack distance using the threaded steel-levelling feet (for vertical adjusting) and the slotted holes (horizontal adjusting). This prevents the weight of the gate from bearing on the operator.

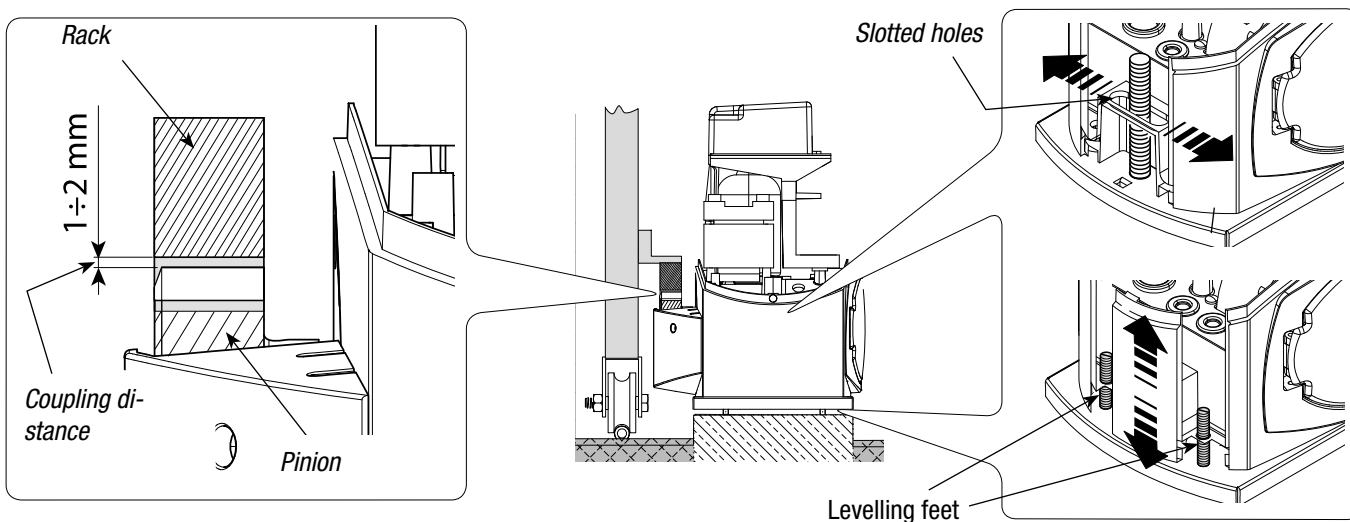

Once adjustments are finished, secure the assembly using the nuts and washers. Insert the cover after performing the adjustments and settings on the electronic card.

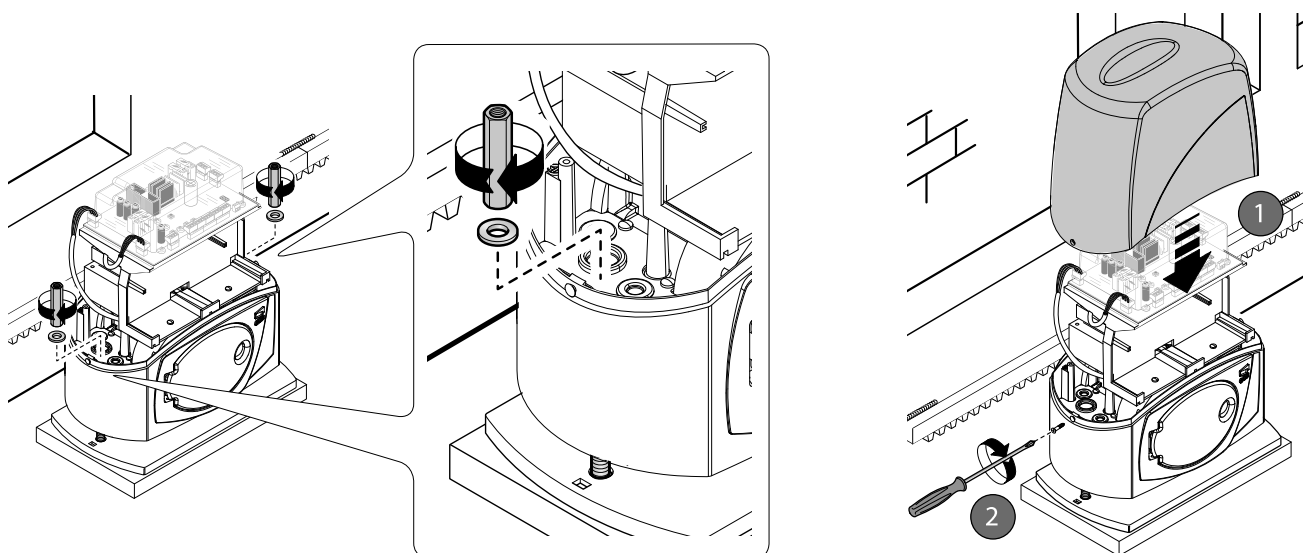

5.6 Adjusting the mechanical stops

Adjusting the opening mechanical stops:

- with the motor in release mode, fully open the gate. Activate the opening-microswitch, turning the white cam clockwise. Secure the cam by turning the screw.

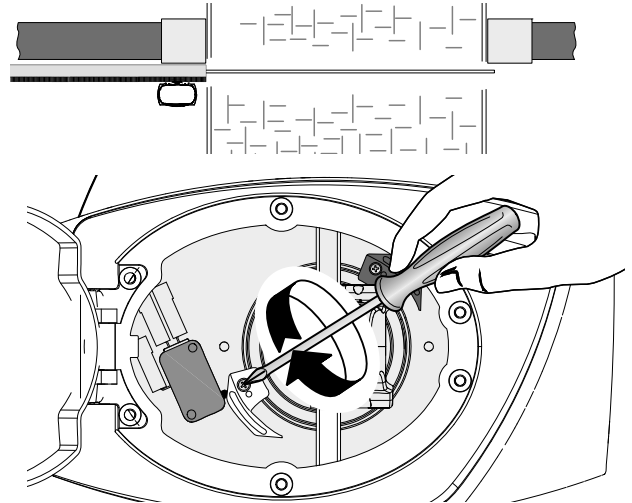
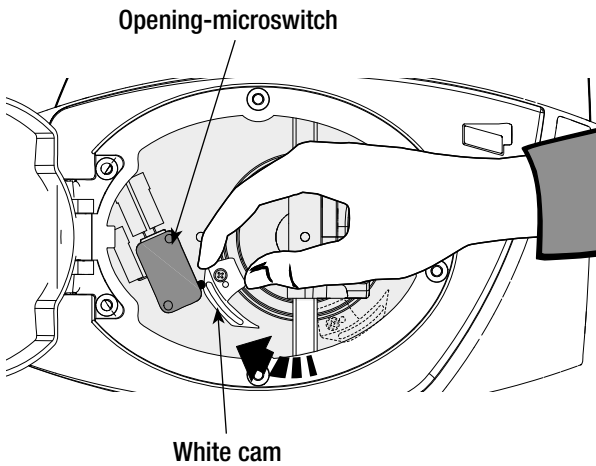

Adjusting the closing endstop:

- with the motor in release mode, fully close the gate. Activate the closing-microswitch, turning the red cam counter-clockwise. Secure the cam by turning the screw.

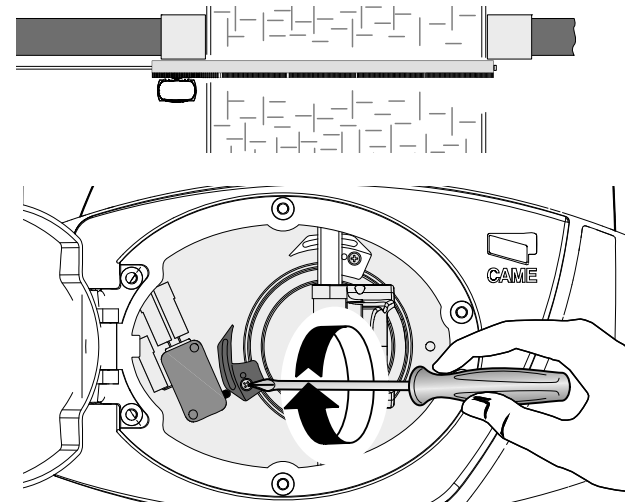
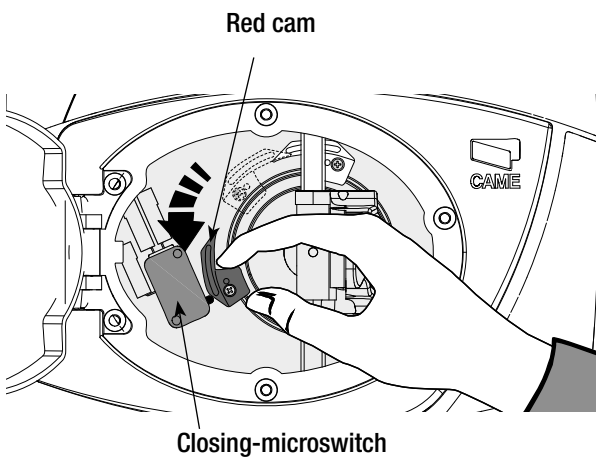

5.7 Manually releasing the gearmotor

- insert the customised key and turn it counter-clockwise. Open the trap door and pull on the release lever.

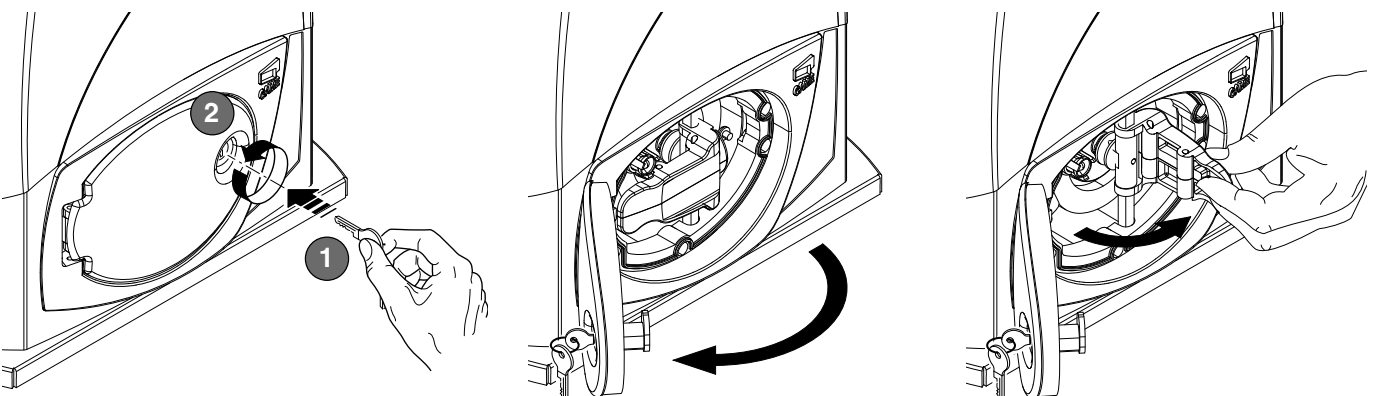

6 Control board

6.1 General description

Use 230V A.C. to power the electronic card using the L-N terminals, at a max 50/60Hz frequency.

Use 24V to power the command devices and accessories. Careful! The accessories cannot exceed 37W of overall power.

The card is fitted with an amperometric device which constantly monitors the motor's drive. When the gate runs into an obstacle, the amperometric sensor immediately detects the overload on the drive and so inverts the gate's movement:

- re-opens the gate while it is in closing-mode (1);

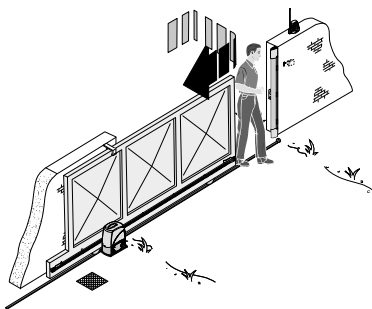

- it recloses the gate while it is in opening-mode.

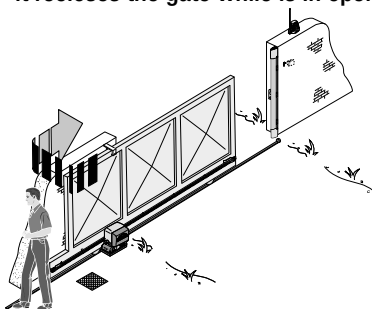

(1) Warning: after 3 obstacle detections, the gate stops when in opening-mode and excludes automatic-closing mode; to regain movement press the command button or use the remote control.

All connections are protected by quick-fuses – see table.

FUSE TABLE	
To protect:	Fuse:
Motor	8A-F
Control board (line)	1,6A-F
Accessories	1.6A-F
Command devices	1A-F

The card handles the following functions:

- Automatic closing after an opening command;
- Warning light pre-flashing;
- Obstacle detection when gate is still at any point;
- Constant monitoring of photocell operations.
- Opening/closing;
- Opening/closing in maintained action mode;
- partial opening;
- total stop.

After detecting an obstacle, the photocells will trigger:

- The reopening of a closing gate;
- The partial stop of a moving gate followed by its automatic closing (if this function has been selected).

After an obstacle is detected the sensitive edges will:

- Reopen the gate if it is closing;
- Close the gate if it is opening.

Apposite trimmers regulate:

- The automatic closing's running time;
- The partial opening;
- The amperometric device's detection sensitivity, in both normal and brake modes;
- the speed of both the normal gate run and the brake mode run.

6.2 Main components

- 1) Power supply terminals
- 2) Endstop terminals
- 3) Motor terminals
- 4) Encoder terminals
- 5) Accessory fuse
- 6) Card fuse
- 7) Button for memorising the radio code
- 8) Radio-code signalling LED indicator
- 9) 230V-power signalling LED
- 10) Control and signalling LED group
- 11) Function selector DIP switch
- 12) Socket for connecting the remote control's radiofrequency card
- 13) Antenna terminal
- 14) Accessories' and command device's terminals
- 15) Motor fuse
- 16) Line fuse
- 17) Setting trimmer

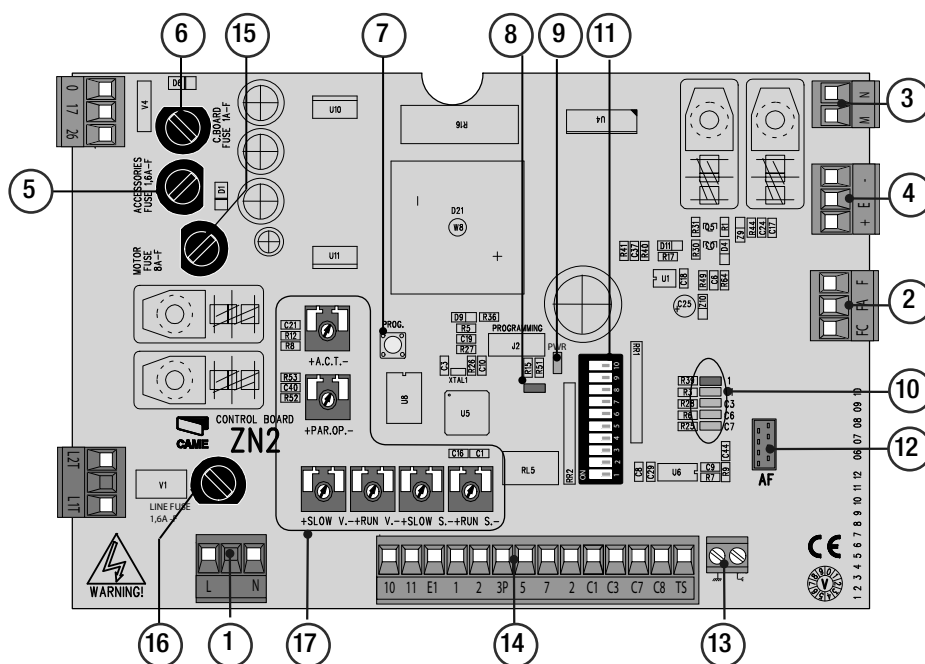

6.3 Electrical connections

Gearmotor, endstop and encoder

Description of the standard electrical connections for left-hand installations

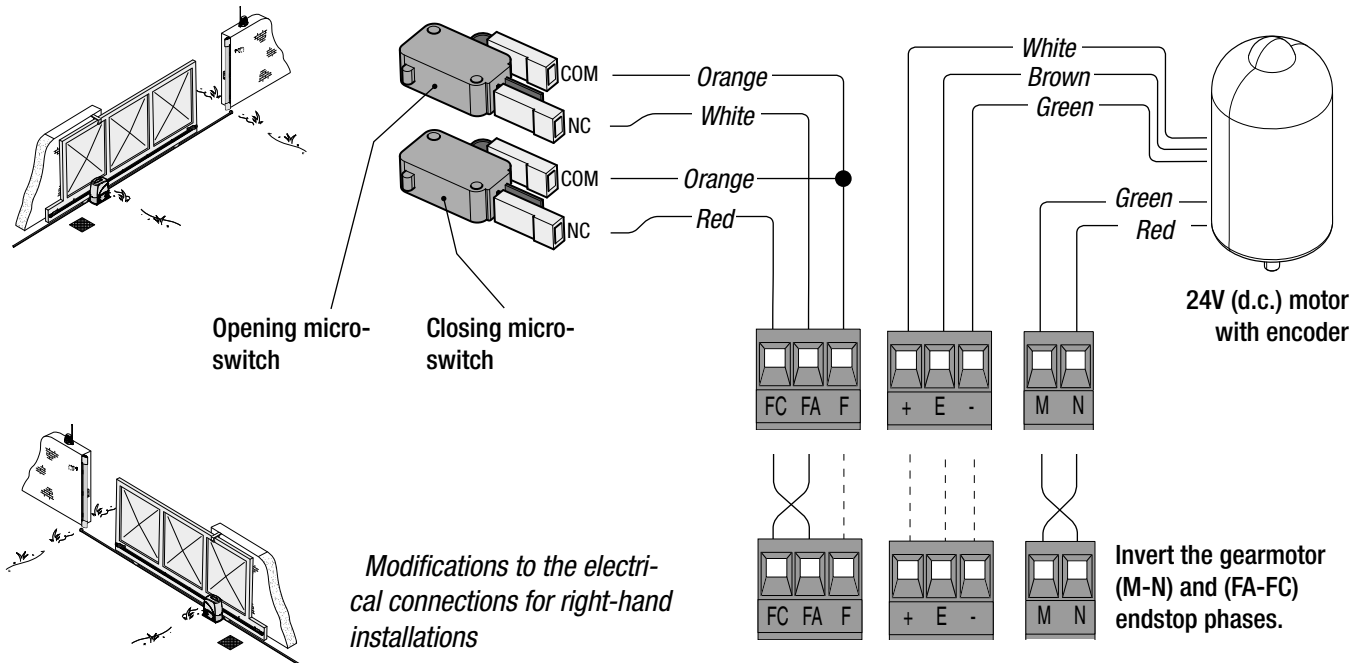

Power supply for accessories

Terminals for powering the following accessories:

- 24V A.C. normally;
 - 24V D.C. when the emergency batteries are working;
- Maximum allowed power: 37W**

230V (a.c.) Power, 50/60Hz frequency



⏚ Cable lug with bolt and washer for connecting to earth.

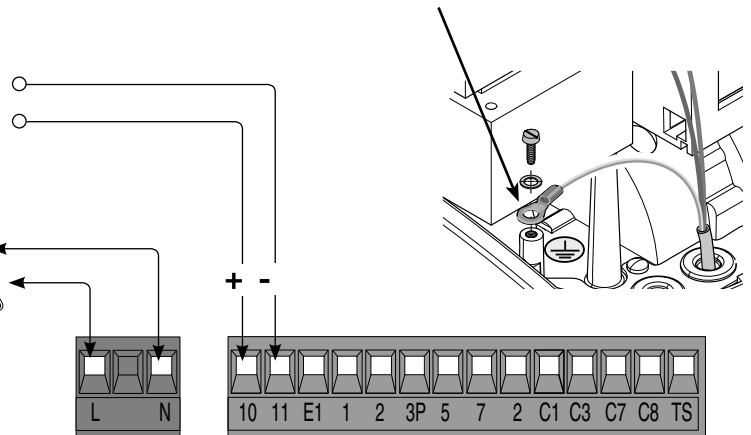

Warning devices

Movement flashing light (Contact range: 24V – 25W max) - Flashes during the gate's opening and closing phases.

Open-gate status light (contact range: 24V – 3W max) - Signal that gate is open; turns off when gate is closed.

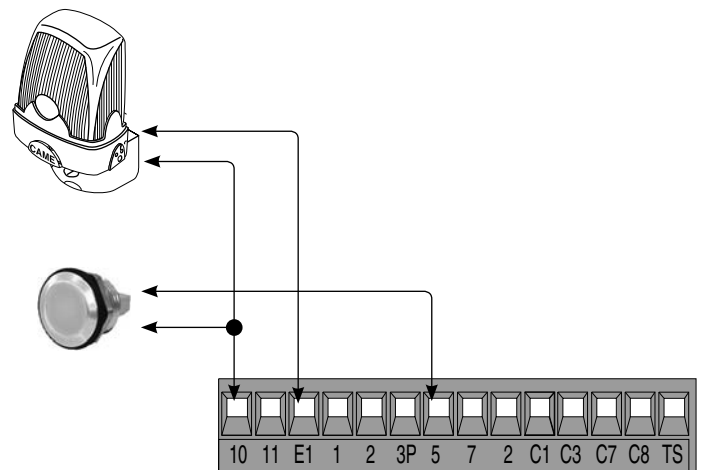

Command and control devices

Stop button (N.C. contact)

- Gate stop button. Excludes automatic closing. For motion to resume, press the command button or the remote control button.

Key selector and/or partial opening button (N.O. contact)

- Partial gate opening for pedestrian access.

Key selector and/or command button (N.O. contact)

- Gate opening and closing command.
By pressing the button or turning the selector key, the gate inverts its movement or stops depending on which the settings on the DIP switches.

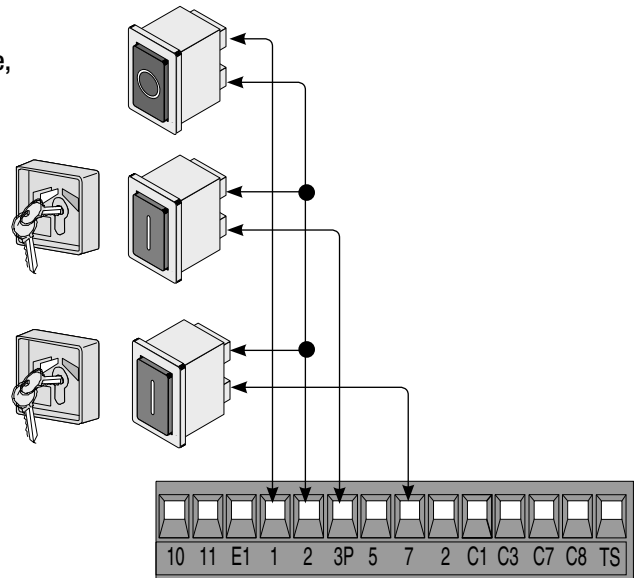

Safety devices

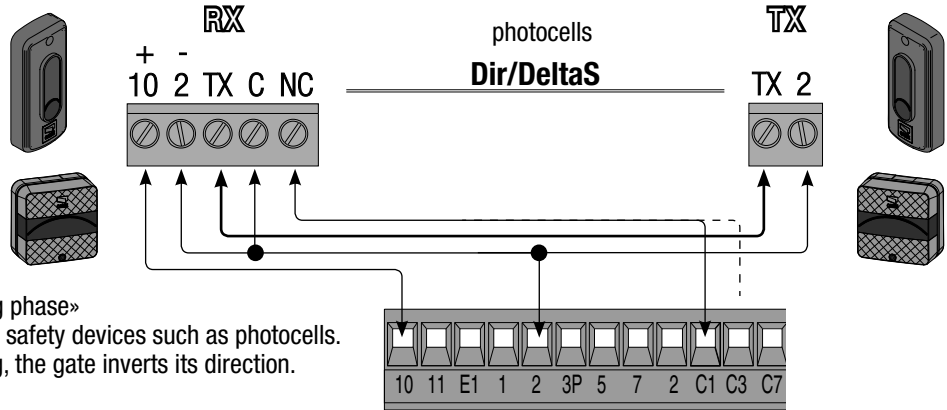

(N.C.) contact for «re-open during closing phase»
- Input for EN 12978 standard-compliant safety devices such as photocells.
If contact is opened, while gate is closing, the gate inverts its direction.

«partial stop» (N.C.) contact
- Input for EN 12978 standard-compliant safety devices such as photocells.
Gate stops if moving and automatically shuts (if this functions has been selected).

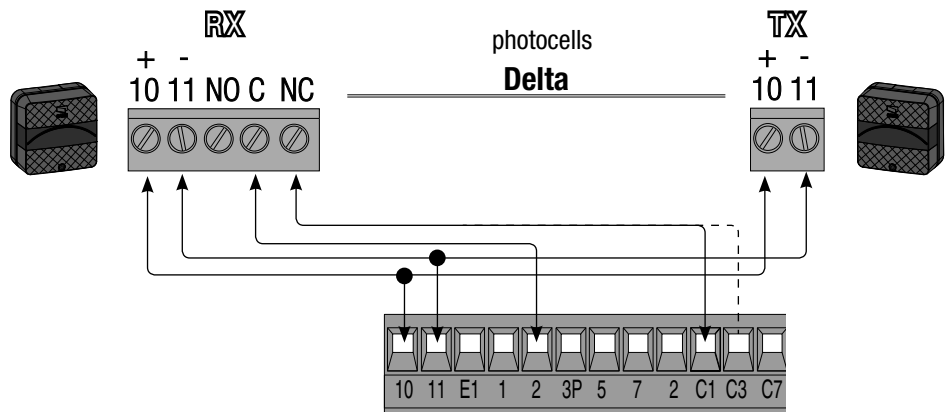

«Open while closing» (N.C.) contact

«Partial stop» (N.C.) contact

«Open while closing» (N.C.) contact
 - input for EN 12978 compliant safety devices such as sensitive edges. During gate closing, opening the contact causes inversion of movement until gate is fully open; if not used, short circuit contact 2-C7.

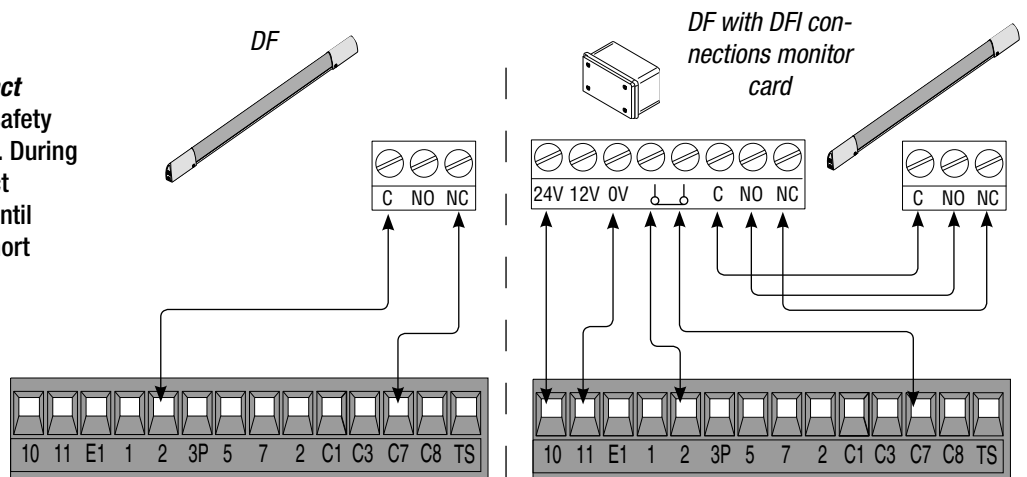

«close while opening» (N.C.) contact
 - input for EN 12978 compliant safety devices such as sensitive edges. During gate opening, opening the contact causes inversion of movement until gate is fully close; if not used, short circuit contact 2-C8.

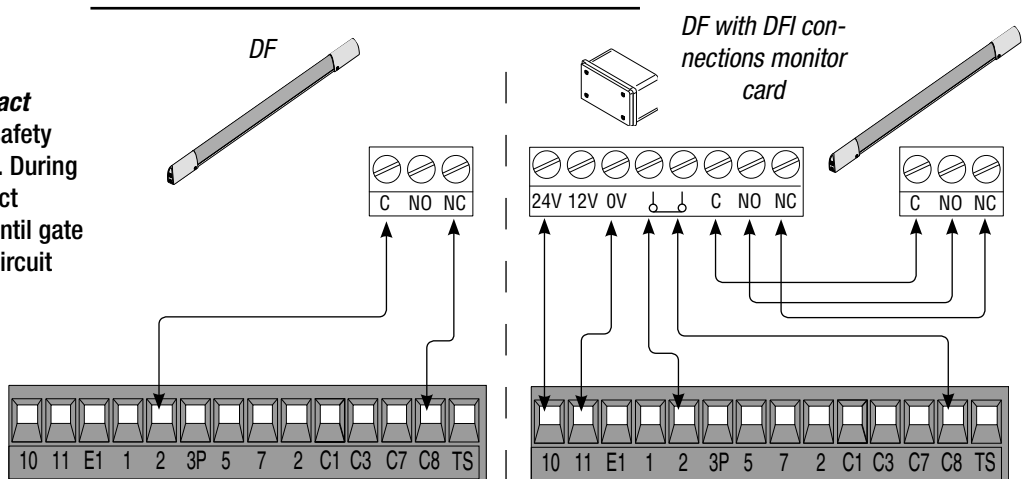

6.4 Electrical connection to operate the photocells' safety test

DELTA

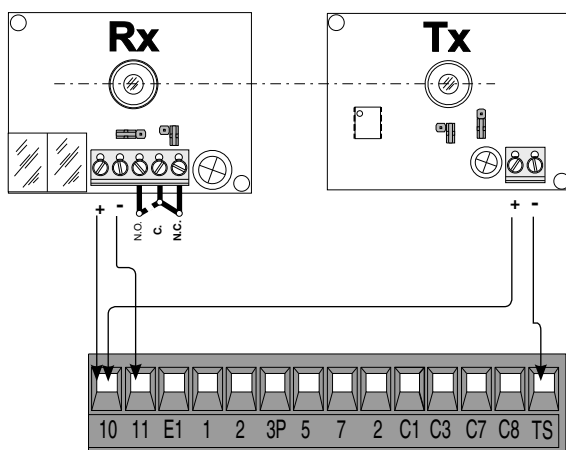

DIR / DELTAS

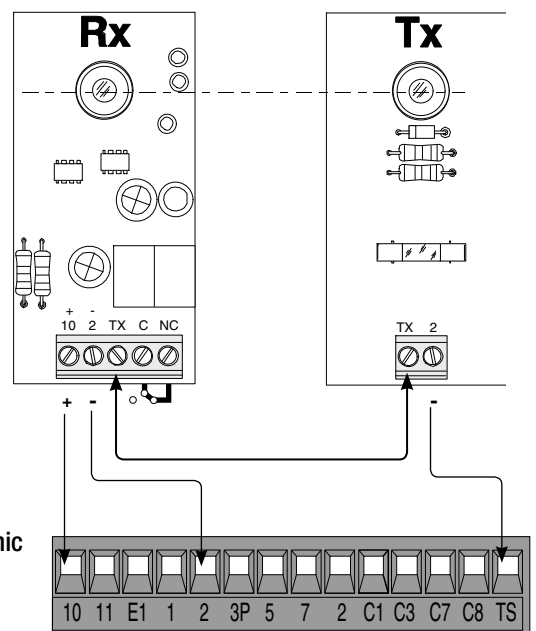

At each open/close command, the card check the photocells' efficiency. Any problems with the photocells will cause the (PROG) Led to flash on the electronic card, which cancels any commands from the radio transmitter or push-button.

Electrical connection to operate the photocells' safety test:

- The transmitter and receiver, must be connected as shown in the diagram;
- Set DIP switch 7 to ON to activate the test.

IMPORTANT:

When the safety test function is activated, the N.C. contacts - if unused - are to be excluded on their relative DIP switches (see chapter "selecting functions").

7 Settings

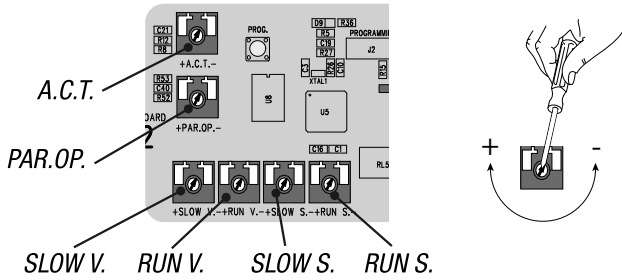

SETTING TRIMMER LIST:

- «**A.C.T.**» Sets the waiting time while open. Once this time has elapsed, closing automatically takes place. The waiting time may be set from 1 to 150 seconds.

- «**PAR.OP.**» Sets the gate's partial opening. By pushing the partial opening button connected at 2-3P, the gate opens depending on the length of the gate.
- «**SLOW S.**» Sets the amperometric sensitivity that controls the force generated by the motor during slow down; if the force exceed the set level, the system intervenes by inverting the direction of motion.
- «**RUN S.**» Sets the amperometric sensitivity that controls the force generated by the motor during movement; if the force exceeds the set level, the system intervenes by inverting the direction of motion.
- «**SLOW V.**» Sets the gate's final opening/closing phase slow-down speeds.
- «**RUN V.**» Sets the gate's opening/closing motion speed.

8 Warning Led

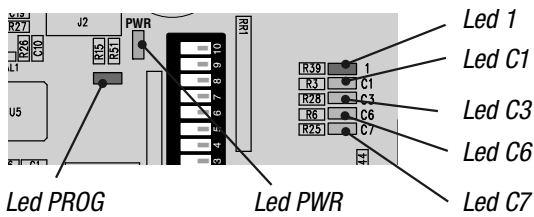

LIST WARNINGS OF THE COMMAND AND SAFETY DEVICES' CONTROL LEDs:

- «**PROG**» Red Led. Normally off. When the transmitter is activating, it turns on or flashes.
- «**PWR**» Green led. Normally on. Shows that card is properly powered;

- «**1**» Yellow led. Normally off. Shows activation of the PARTIAL STOP button
- «**C1**» Yellow led. Normally off. Shows that there are obstacles between the photocells (which are in OPEN WHILE CLOSING mode).
- «**C3**» Yellow Led. Normally off. Shows that there are obstacles between the photocells (which are in PARTIAL STOP mode).
- «**C6**» Yellow Led. Normally off. Show obstacles detected by the sensitive edge (which are in OPEN WHILE CLOSING mode).
- «**C7**» Yellow Led. Normally off. Shows obstacles detected by sensitive edge (which are in CLOSE WHILE OPENING mode).

9 Function selector

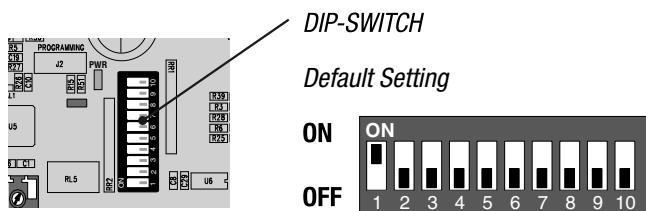

- 1 ON - **Automatic Closing** - The automatic closing timer activates at the end of the opening gate run. The pre-set time is adjustable, and is in any case conditioned by the activation of any safety devices, and does not activate after a total safety "stop" or during a blackout.
- 2 ON - **"Open-stop-close-stop"** function with [2-7] button and radio transmitter (fitted with inserted radiofrequency card).
- 2 OFF - **"Open-close"** function with [2-7] button and radio transmitter (fitted with inserted radiofrequency card).
- 3 ON - **"Open only"** function with [2-7] button and radio transmitter (fitted with inserted radiofrequency card).
- 4 ON - **Pre-Opening and closing flasher** - Following and opening and closing command, the flasher connected to [10-E1], flashes for 5 seconds before motion begins.

- 5 ON - **Obstacle detected** - When motor is stopped (gate closed or after a total stop command) it prevents any movement if safety devices, such as photocells, detect any obstacles.
- 6 ON - **Maintained action** - The gate works by keeping button pressed (one 2-3P opening button, and one 2-7 closing button).
- 7 ON - **Functioning of the photocells' safety test** - Allows the card to check the efficiency of any safety devices (i.e. photocells) after every opening or closing command.
- 8 OFF - **Total stop** - This function stops the gate and then excludes any automatic closing cycle; to set in motion again, use either the keypad or transmitter. Insert the safety device in [1-2]; if unused, set DIP switch to ON.
- 9 OFF - **Opening during closing** - If the photocells detect an obstacle during gate's closing, gate motion is inverted until fully opened; connect the safety device to terminals [2-C1]; if unused, set DIP switch to ON.
- 10 OFF - **Partial stop** - Gate stop when obstacle is detected by the safety device; once obstacle is removed, the gate remains still or closes if automatic closing is activated. Connect the safety device to terminal [2-C3]; if unused, set the DIP switch to ON.

10 Programming to save gate-run and decelerations adjustments

Do the adjustment by making the operator execute a complete opening/closing manoeuvre
The control board automatically registers the gate-run adjustments with opening and closing decelerations.

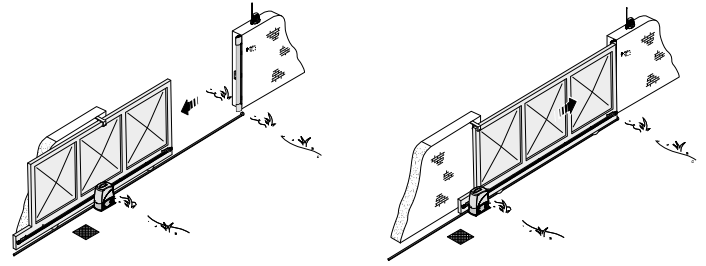

To save the adjustment, position dip 6 in ON and press PROG button until the signalling led stays on.
Re-position the dip in OFF

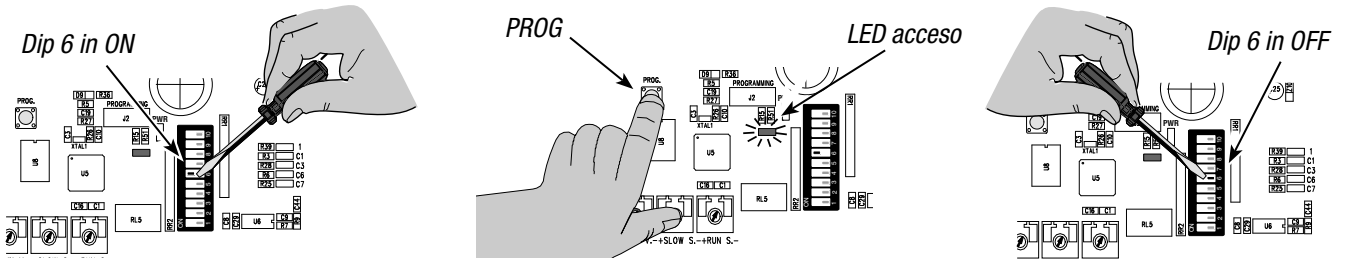

11 Activating the radio control

- A** Connect the antenna's RG58 cable.
- ⚠ Cut off the main power supply, and remove any batteries.
- B** Fit the AF board onto the electronic board.
- 📖 The electronic board recognizes the AF board only when the operator is powered up again.
- C** Keep the CH1 button on the electronic board pressed: the warning LED flashes.
- D** Press any button on the transmitter to send the code: the LED will stay on to let you know that the code has been stored. Repeat **C/D** for any other transmitter buttons.

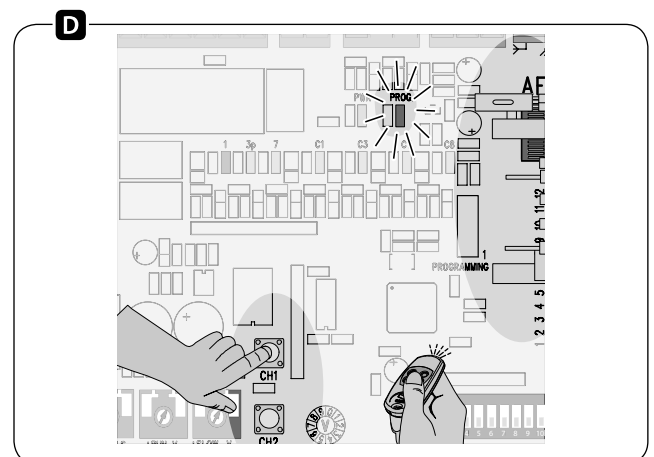
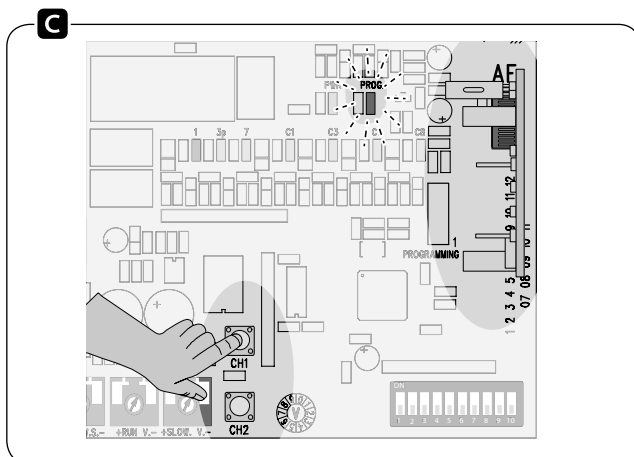
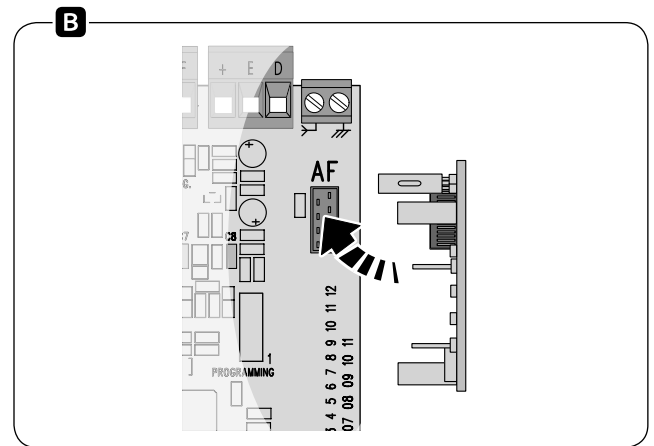
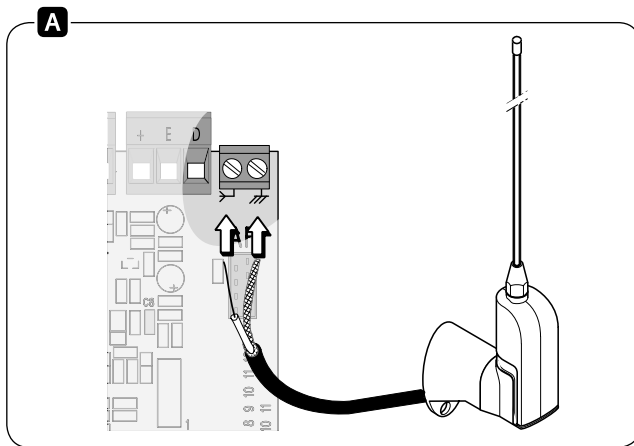

12 Connecting two coupled gearmotors having a single control

With two coupled gearmotors, you can command only the opening (by button and/or radio control): the gate will close only in automatic closing mode.

- Coordinate the direction of travel of the two gearmotors **A** and **B**, by modifying the motor's rotation **B** (invert the cables on terminals FA-FC and M-N).

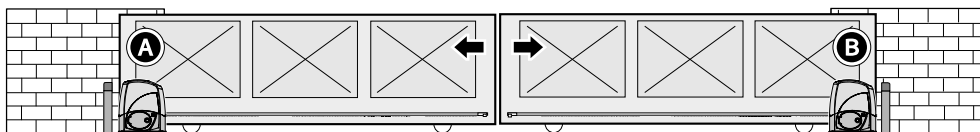

- Make the electrical connections only on the motor's control board **A**.

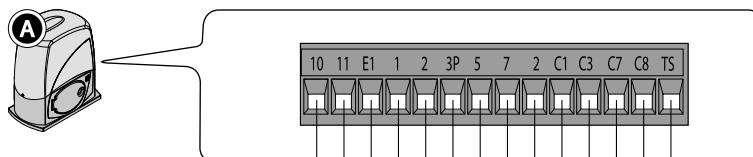

- Whereas, the adjustments and features, must be made on both boards.

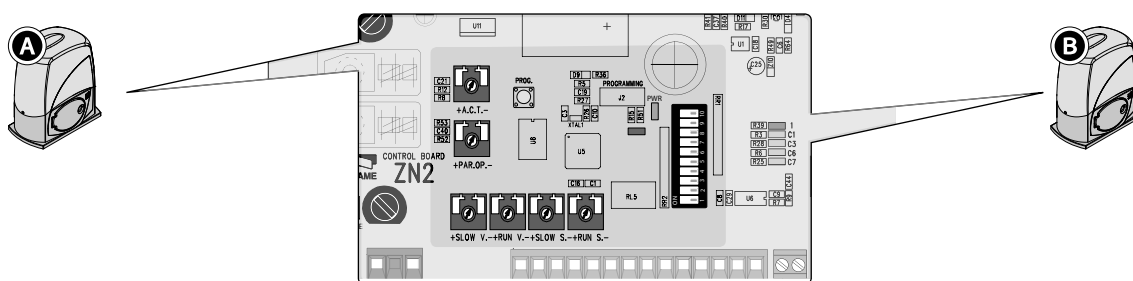

- Connect the two boards together, as illustrated.

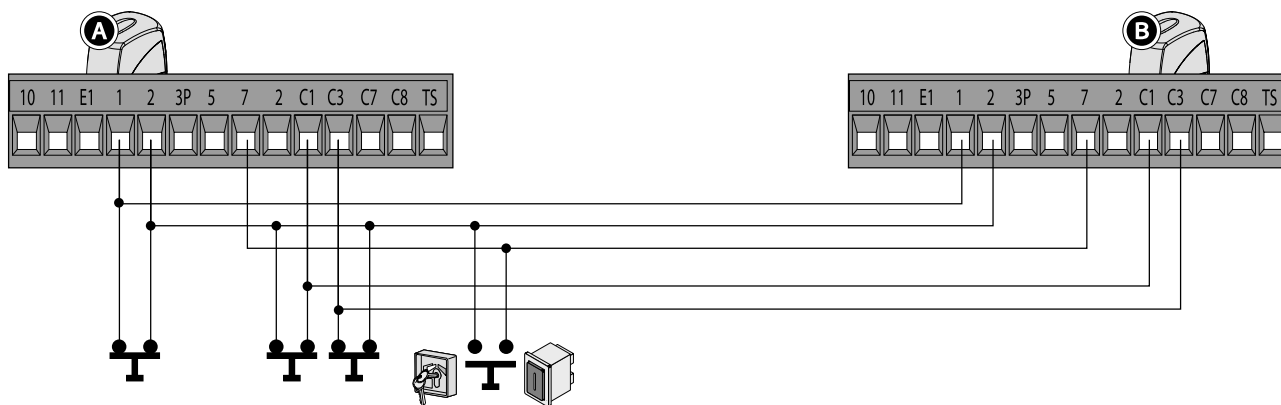

- Set DIP 2 and 1 to ON on both boards.



For opening with a radio control, connect an external receiver (RExxx/RBExxx with relay in MONOSTABLE mode) on terminals 2-7 of the motor **A**.

13 Safety instructions

Important safety instructions

This product must only be employed for its originally intended use. Any other use is wrong and potentially dangerous. The manufacturer cannot be held liable for any damages resulting from wrongful, erroneous or negligent uses.

Avoid working close to the hinges or other moving mechanical parts. Stay out of the opening/closing arc when operator is in motion. Do not exercise force against the motion of the operator as this could result in potentially dangerous situations. Do not allow children to play or loiter within the opening/closing arc of the operator. Keep remote controls and any other command device out the reach of children, to prevent operator from being activated by accident.

In the event of anomalous behaviour, stop using the operator immediately.

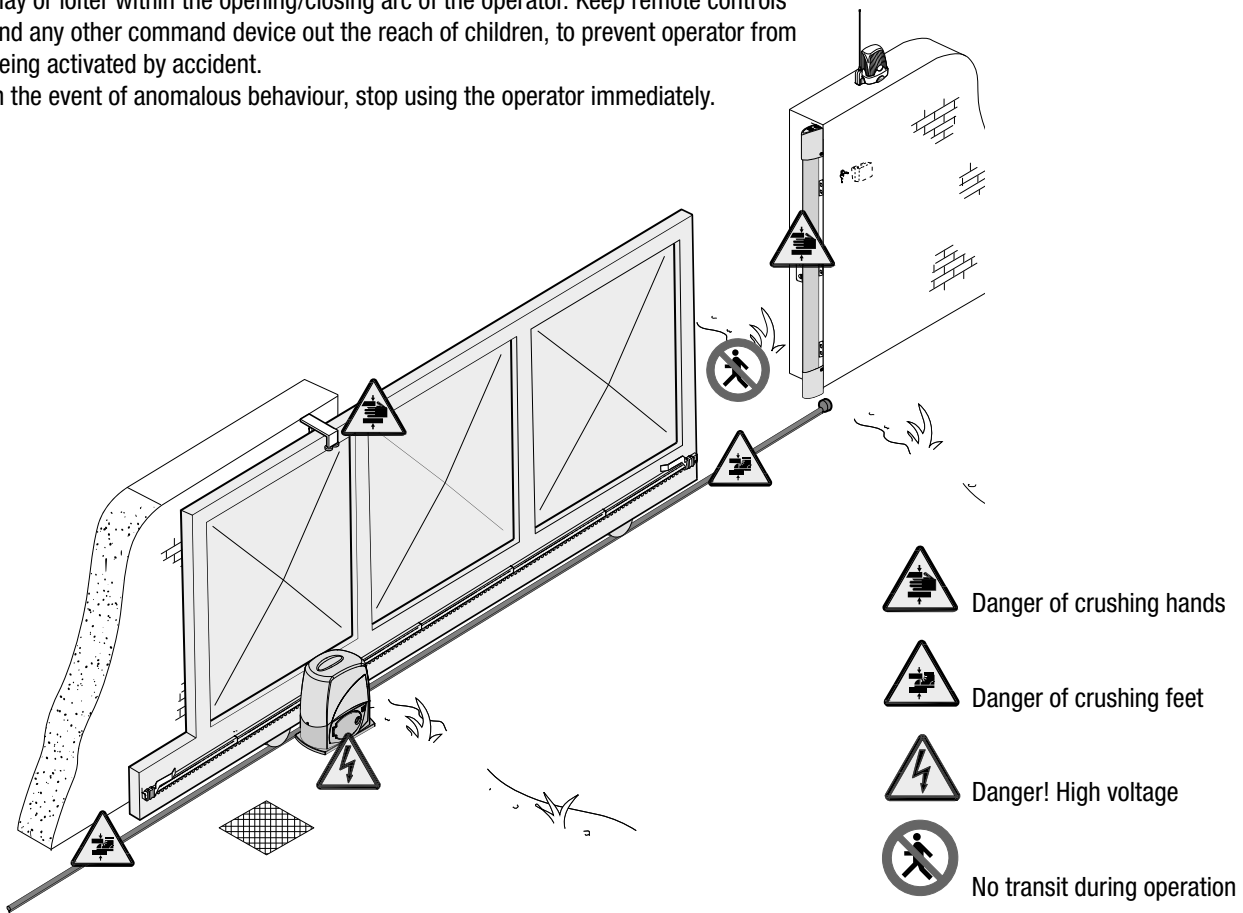

14 Maintenance

14.1 Periodic maintenance

 Periodic maintenance to be carried out by the end-user is as follows: wipe clean the glass surface of the photocells; check that the safety devices work properly; remove any obstructions.

We suggest checking the state of lubrication and tightness of the anchoring screws on the operator.

-To check the efficiency of the safety devices, move an object in front of the photocells when gate is closing. If the operator inverts the motion or stops, the photocells are working properly.

This is the only maintenance procedure to be carried out with the power source connected.

-Before performing any maintenance procedures, cut off the main power, to prevent possible accidents due to gate movement.

-To clean the photocells use a water dampened cloth. Do not use solvents or other chemical products which may ruin the devices.

-In the event of any strange vibrations or squeaking, lubricate the joints with grease, as shown in the diagram.

-Make sure there are no plants within the photocell's beam, and that the gate motion is free of any obstacles.

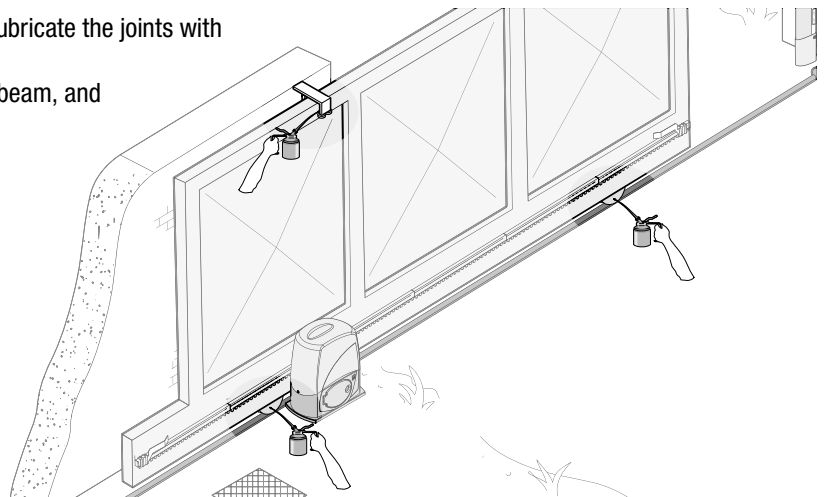

Extra-ordinary maintenance log

Installer's stamp	Operator name
	Date of job
	Technician's signature
	Requester's signature
Job performed _____ _____ _____	

Installer's stamp	Operator name
	Date of job
	Technician's signature
	Requester's signature
Job performed _____ _____ _____	

Installer's stamp	Operator name
	Date of job
	Technician's signature
	Requester's signature
Job performed _____ _____ _____	

Installer's stamp	Operator name
	Date of job
	Technician's signature
	Requester's signature
Job performed _____ _____ _____	

15 Phasing out and disposal

 CAME CANCELLI AUTOMATICI S.p.A. employs a UNI EN ISO 14001 certified and compliant environmental protection system at its plants, to ensure that environmental safeguarding.

We ask you to keep protecting the environment, as CAME deems it to be one of the fundamental points of its market operations strategies, by simply following these brief guidelines when disposing:

DISPOSING THE PACKING MATERIALS

The packing components (cardboard, plastic, etc.) are solid urban waste and may be disposed of without any particular difficulty, by simply separating them so that they can be recycled.

Before actions it is always advisable to check the pertinent legislation where installation will take place.

DO NOT DISPOSE OF IN NATURE!

DISPOSING OF THE PRODUCT

Our products are made using different types of materials. The majority of them (aluminium, plastic, iron, electric cables) can be considered to be solid urban waste. They may be recycled at authorised firms.

Other components (electrical circuit board, remote control batteries etc.) may contain hazardous waste.

They must, thus, be removed and turned in to licensed firms for their disposal.

Before acting always check the local laws on the matter.

DO NOT DISPOSE OF IN NATURE!

16 Declaration of conformity

Declaration **CE** - Came Cancelli Automatici S.p.A. declares that this device complies with the essential requirements and other relevant provisions established in Directives 2006/42/EC and 2004/108/EC.

A true copy of the declaration of conformity is available upon request.



English - Manual code: **119BU30** ver. 2 04/2014 © CAME cancelli automatici s.p.a.
The data and information reported in this installation manual are susceptible to change at any time and without obligation on CAME cancelli automatici s.p.a. to notify users.

IT • Per ogni ulteriore informazione su azienda, prodotti e assistenza nella vostra lingua:
EN • For any further information on company, products and assistance in your language:
FR • Pour toute autre information sur la société, les produits et l'assistance dans votre langue :

DE • Weitere Infos über Unternehmen, Produkte und Kundendienst bei:

ES • Por cualquier información sobre la empresa, los productos y asistencia en su idioma:

NL • Voor meer informatie over het bedrijf, de producten en hulp in uw eigen taal:

PT • Para toda e qualquer informação acerca da empresa, de produtos e assistência técnica, em sua língua:

PL • Wszystkie inne informacje dotyczące firmy, produktów oraz usług i pomocy technicznej w Waszym języku znajdują się na stronie:

RU • Для получения дополнительной информации о компании, продукции и сервисной поддержке на вашем языке:

HU • A vállalatra, termékeire és a műszaki szervizre vonatkozó minden további információért az Ön nyelvén:

HR • Za sve dodatne informacije o poduzeću, proizvodima i tehničkoj podršci:

UK • Для отримання будь-якої іншої інформації про компанію, продукцію та технічну підтримку:



www.came.com



CAMEGROUP

CAME Cancelli Automatici S.p.a.

Via Martiri Della Libertà, 15
31030 **Dosson Di Casier** (TV)

📞 (+39) 0422 4940

📠 (+39) 0422 4941

Assistenza Tecnica/Numero Verde 800 295830