

AUTOMATION SYSTEMS FOR SLIDING GATES

**BX** SERIES



INSTALLATION MANUAL

**BX-74 / BX-78**

English

EN

## “IMPORTANT INSTALLATION, SAFETY INSTRUCTIONS”

“CAUTION: IMPROPER INSTALLATION MAY CAUSE SERIOUS DAMAGE, FOLLOW ALL INSTALLATION INSTRUCTIONS CAREFULLY”

“THIS MANUAL IS ONLY FOR PROFESSIONAL OR QUALIFIED INSTALLERS”



## 1 Legend of symbols



This symbol tells you to read the section with particular care.



This symbol tells you that the sections concern safety issues.



This symbol tells you what to say to the end-users.

## 2 Conditions of use

### 2.1 Intended use

The BX-74 motor is designed to operate residential sliding gates; while, the BX-78 may also be used in condominiums.



Do not install or use unless as otherwise shown in this manual.

### 2.2 Limitations to use

BX-74: max weight of the gate is 400 kg.

BX-78: max weight of the gate is 800 kg; for condominium use it is 600 kg.

## 3 Reference standards

The company CAME cancelli automatici is ISO 9001:2000 quality certified; it has also obtained the ISO 14001 environmental safeguarding certification. CAME engineers and manufactures all of its products in Italy.

This product complies with the following legislation: *see declaration of compliance.*

## 4 Description

### 4.1 Operator

This product is engineered and manufactured by CAME CANCELLI AUTOMATICI S.p.A. in compliance with current safety standards. Guaranteed 24 months if not tampered with.

The operator is made of a cast aluminium part inside of which operates the irreversible, electromechanical gearmotor and an ABS plastic lining which holds the electronic card and transformer

**Important!** Check that the command, safety equipment and accessories are CAME originals; this guarantees and make the installation easy to operate and maintain.

### 4.2 Technical features

#### BX-74 OPERATOR

Control panel power supply: 230V A.C. 50/60Hz

Operator power supply: 230V A.C. 50/60Hz

Draw max.: 2,6A

Power: 200W

Max Torque: 24 Nm

Reduction ratio: 1/33

Thrust: 300 N

Max speed: 10 m/min

Operative intermittence: 30%

Protection rating: IP54

Insulation class: I

Weight: 15 kg

Capacitor: 12 µF

Engine thermoprotection: 150° C

#### BX-78 OPERATOR

Control panel power supply: 230V A.C. 50/60Hz

Operator power supply: 230V A.C. 50/60Hz

Draw max.: 2,4A

Power: 300W

Max Torque: 32 Nm

Reduction ratio: 1/33

Thrust: 800 N

Max speed: 10 m/min

Operative intermittence: 30%

Protection rating: IP54

Insulation class: I

Weight: 15 kg

Capacitor: 20 µF

Engine thermoprotection: 150° C

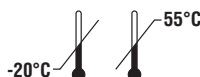

## 4.3 Description of parts

- 1 - Top cover
- 2 - Settings casing
- 3 - Control board support
- 4 - Endstop fins
- 5 - ZB74-78 electronic card
- 6 - Front cover to control panel
- 7 - Gearmotor release door
- 8 - Securing plate
- 9- Securing bolt
- 10- Securing screw plate
- 11- Nut

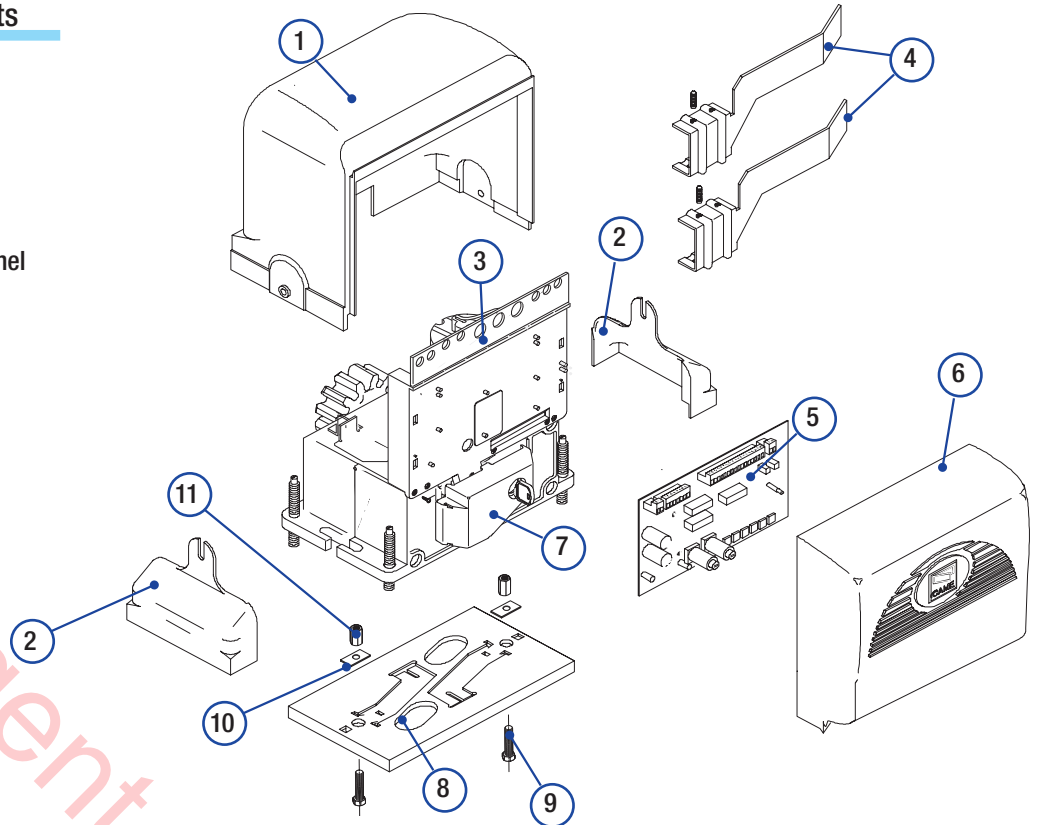

## 4.4 Dimensions

(mm)

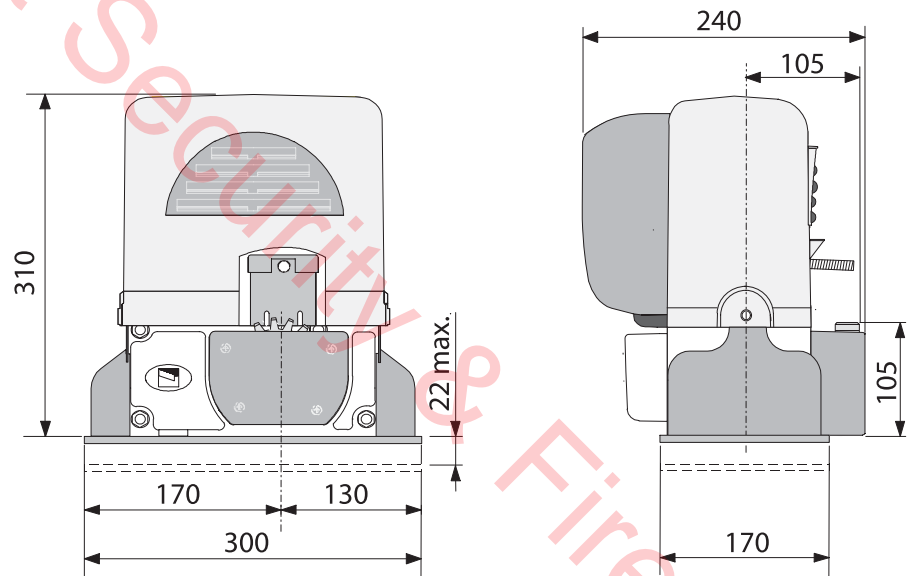

## 5 Installation

**⚠** Installation must be carried out by expert qualified personnel and in full compliance with current regulations.

### 5.1 Preliminary checks

**⚠** Before installing, do the following:

- Make sure that the gate is stable, and that the castors are in good working order and properly greased.
- The ground rack must be well secured to the ground, entirely above the surface and free of any irregularities that may obstruct the gate's movement.
- The upper guide rails must not create any friction.
- Make sure that there is a closing and an opening endstops.
- Make sure that the operator is attached to a solid surface and protected from any impacts;
- Make sure you have a suitable omnipolar cut-off device with contacts more than 3 mm apart, and independent (sectioned off) power supply;
- $\perp$  Check that any connections inside the container (that provide continuity to the safety circuit) are fitted with additional insulation compared to other internal live parts;
- Make sure you have suitable tubing and conduits for the electrical cables to pass through and be protected against mechanical damage.

## 5.2 Tools and materials

Make sure you have all the tools and materials you will need for the installation at hand to work in total safety and compliance with the current standards and regulations. The following figure illustrates the minimum equipment needed by the installer.

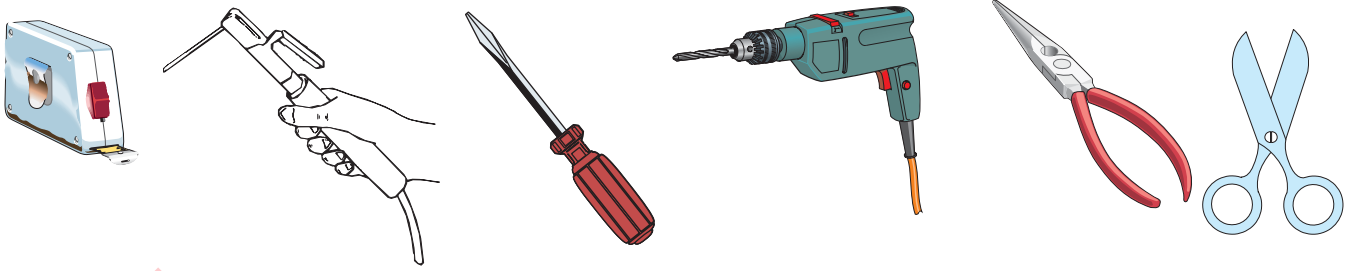

## 5.3 Cable list and minimum thickness

Connection	Type of cable	Length of cable 1 < 10 m	Leng. cable 10 < 20 m	Leng. cable 20 < 30 m
Control panel power supply 230V	FROR CEI 20-22 CEI EN 50267-2-1	3G x 1,5 mm <sup>2</sup>	3G x 2,5 mm <sup>2</sup>	3G x 4 mm <sup>2</sup>
Flashing light		2 x 0,5 mm <sup>2</sup>	2 x 1 mm <sup>2</sup>	2 x 1,5 mm <sup>2</sup>
Photocell transmitter		2 x 0,5 mm <sup>2</sup>	2 x 0,5 mm <sup>2</sup>	2 x 0,5 mm <sup>2</sup>
Photocell receiver		4 x 0,5 mm <sup>2</sup>	4 x 0,5 mm <sup>2</sup>	4 x 0,5 mm <sup>2</sup>
Accessories power supply		2 x 0,5 mm <sup>2</sup>	2 x 0,5 mm <sup>2</sup>	2 x 1 mm <sup>2</sup>
Safety and control devices		2 x 0,5 mm <sup>2</sup>	2 x 0,5 mm <sup>2</sup>	2 x 0,5 mm <sup>2</sup>
Antenna connection	RG58	max. 10 m		

N.B.: If the cable length differs from that specified in the table, then you must determine the proper cable diameter in the basis of the actual power draw by the connected devices and depending on the standards specified in CEI EN 60204-1.

For connections that require several, sequential loads, the sizes given on the table must be re-evaluated based on actual power draw and distances. When connecting products that are not specified in this manual, please follow the documentation provided with said products.

## 5.4 Standard installation

- 1) BX74-78 assembly
- 2) Rack
- 3) Reception Antenna
- 4) Flashing light
- 5) Keyswitch selector
- 6) Safety photocells
- 7) Electric cable junction box
- 8) Mechanical endstops
- 9) Guide rails
- 10) Endstop fins

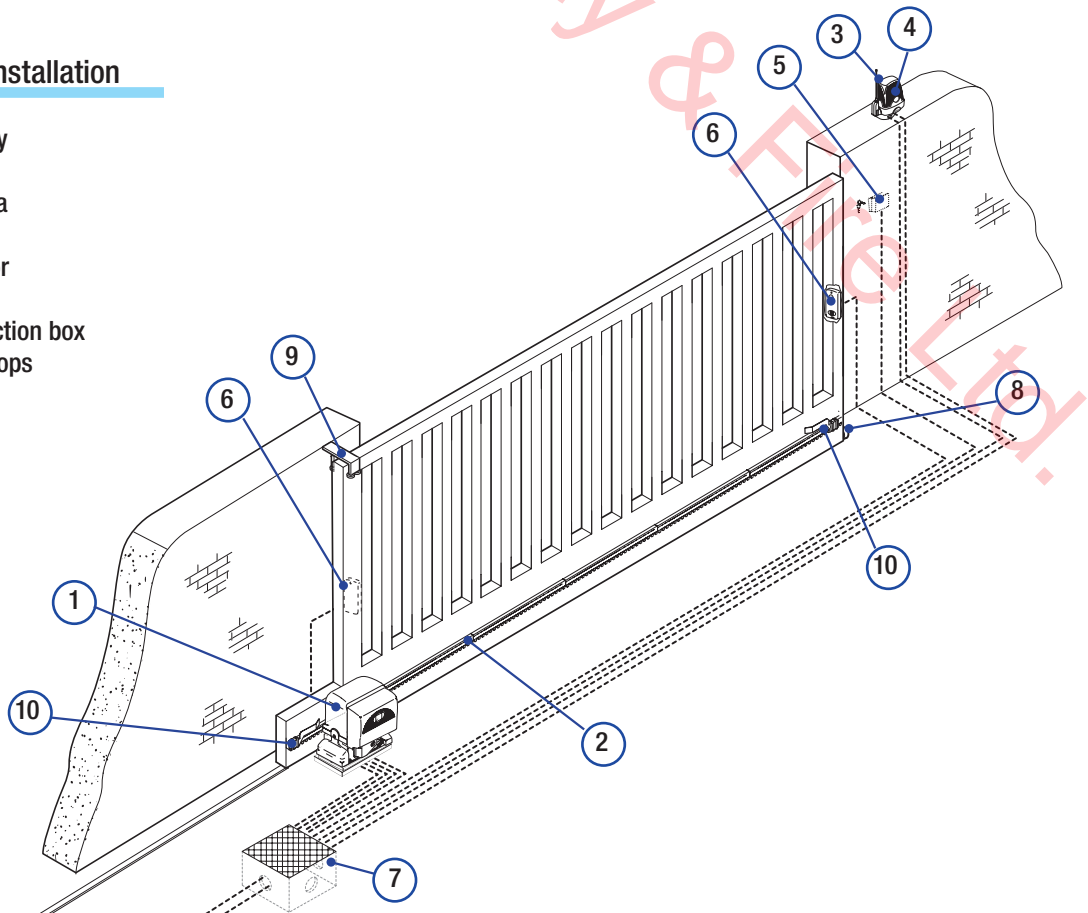

## 5.5 Securing the plate and installing the assembly

**!** The following applications are only examples, as the space for installing the ratiomotor and accessories varies according to obstructions. It is thus up to the system installer to select the most suitable solution.

- Dig a pit to the side of the gate (see measurements from diagram).

Prepare the corrugated tubes you will need when making connections coming from the shunt pit.

N.B. the number of tubes depends on the type of system and the accessories you will hook up.

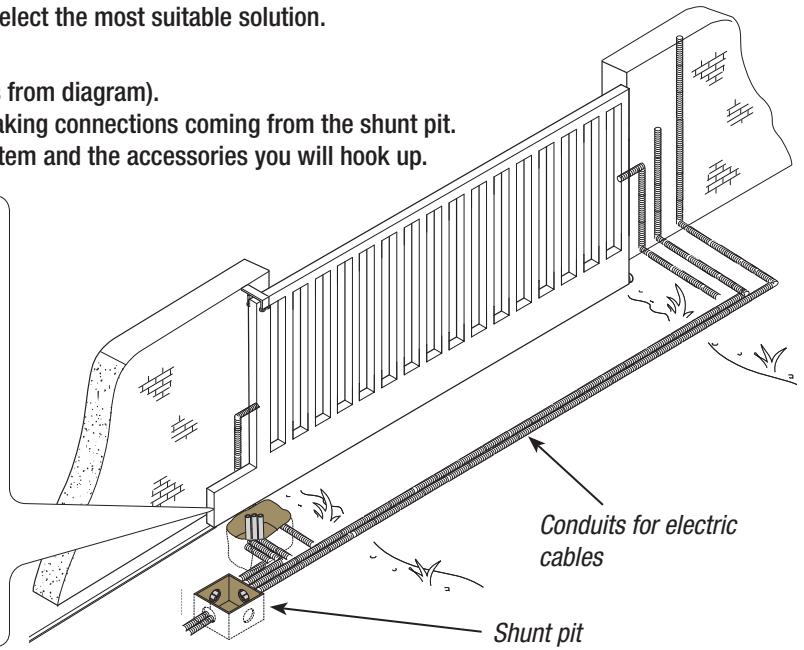
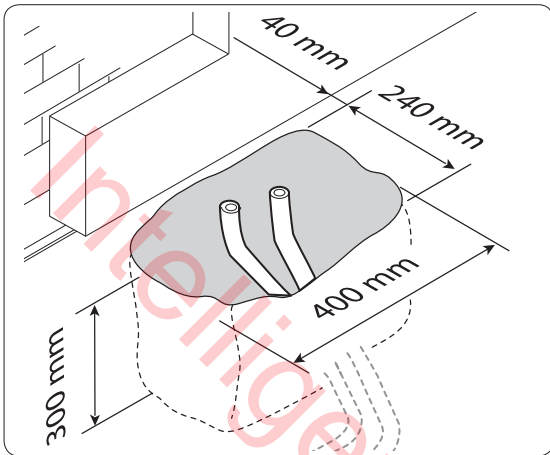

- Prepare a form box that is larger in size than the securing plate and insert it into the pit. The form box should jut 50mm above ground level.

Insert an iron grid inside the form box to reinforce the concrete.

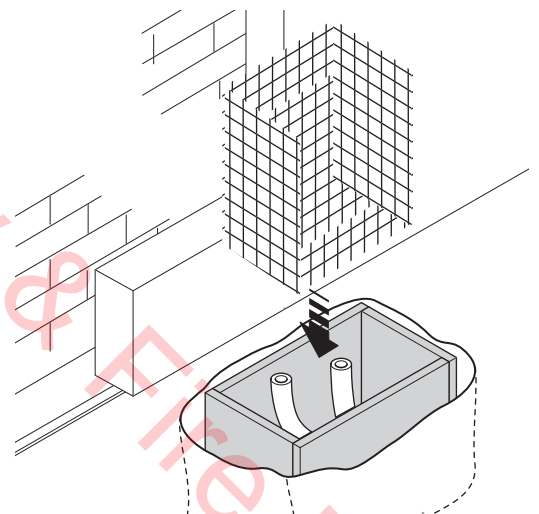
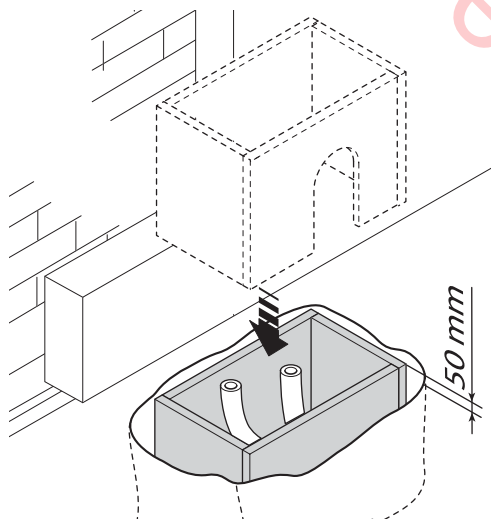

- Prepare the securing plate, insert the bolts into the holes and lock them using the supplied nuts and washers. Extract the preformed brackets using a screw driver or a set of pliers.

- Position the plate on top of the grid. Careful! The tubes need to pass through the opposite holes.

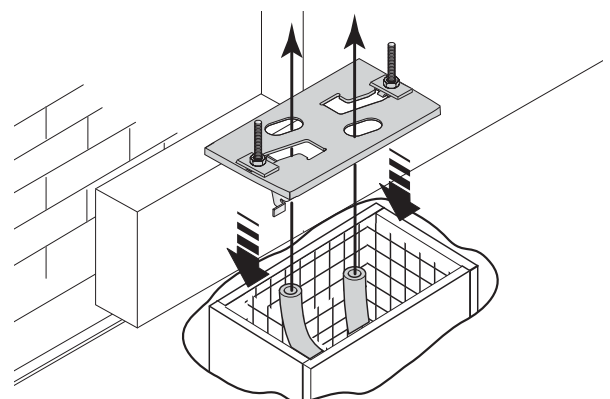
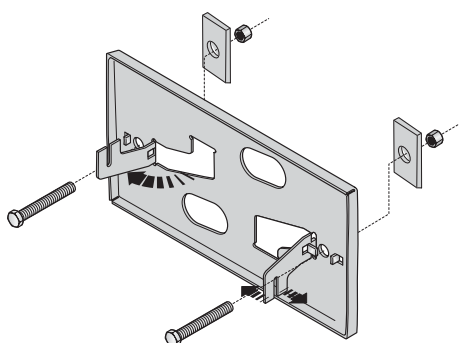

- To position the plate in relation to the rack please see the measurements on the diagram.  
Fill the form box with cement and wait for at least 24 hours for it to solidify.

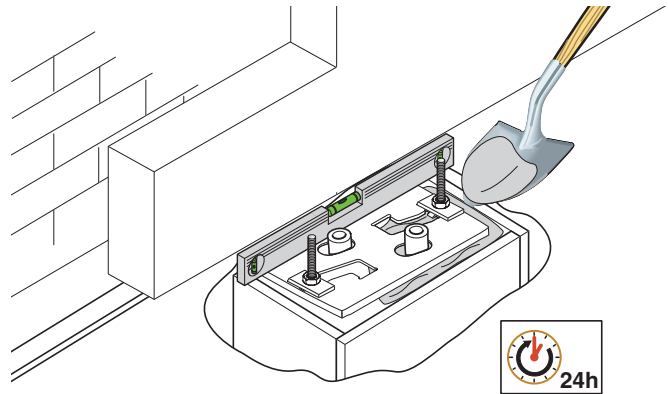
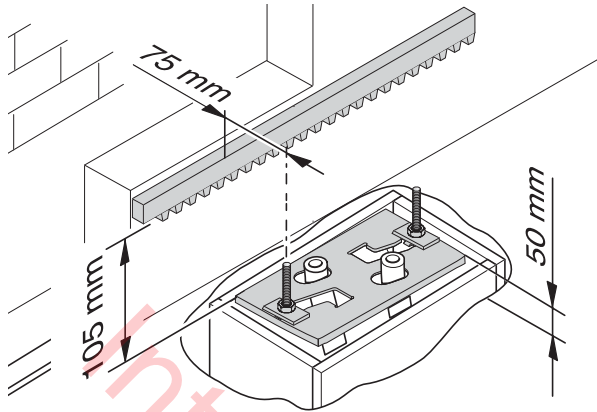

- Remove the form box, fill the pit around the cement block with soil.

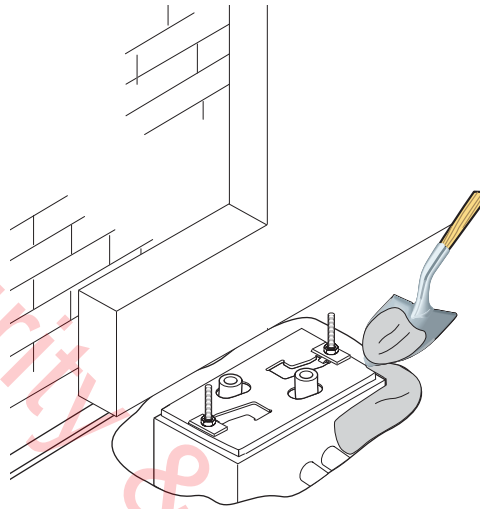
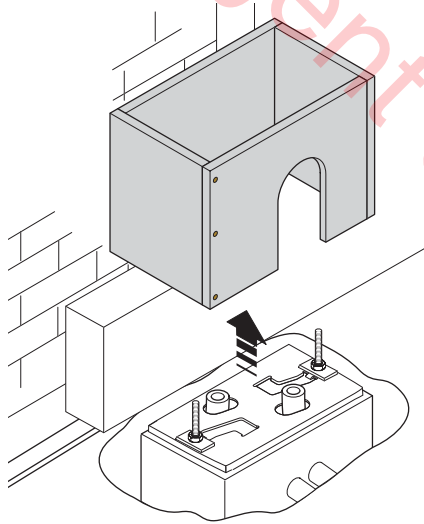

- Unbolt the nuts and washers from the bolts. The securing plate must be clean, perfectly aligned and with the bolt threads completely on the surface.  
Insert the electric cables into the tubes until they exit about 400mm.

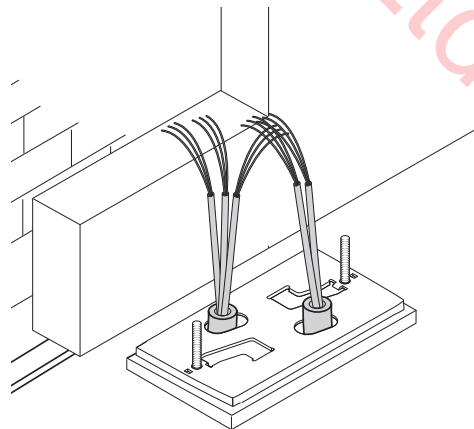
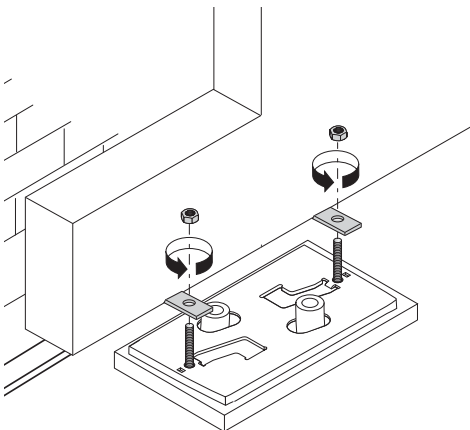

- Remove the cover from the gearmotor by loosening the side bolts, perforate the cable shafts using a screwdriver or a pair of scissors and position the gearmotor atop the plate. Careful! The electric cables must pass through the cable shafts.

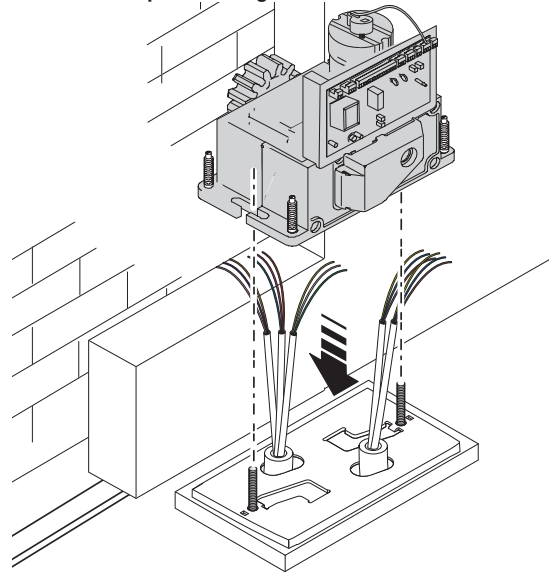
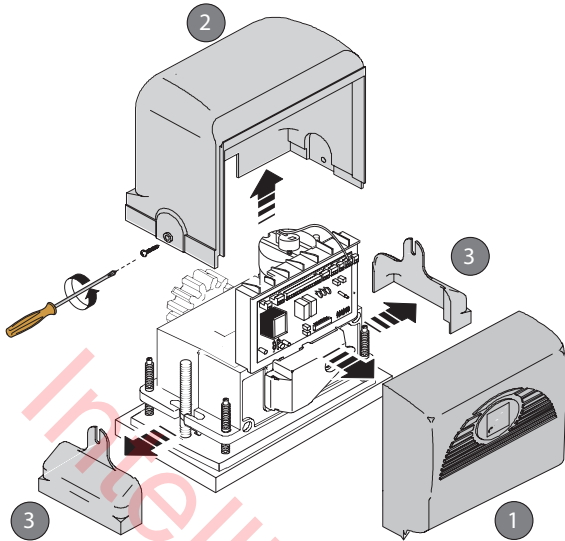

- Lift the gearmotor from the securing plate by about 5 to 10mm by using the threaded steel-leveling feet to allow any later adjustments between the pinion and the rack.

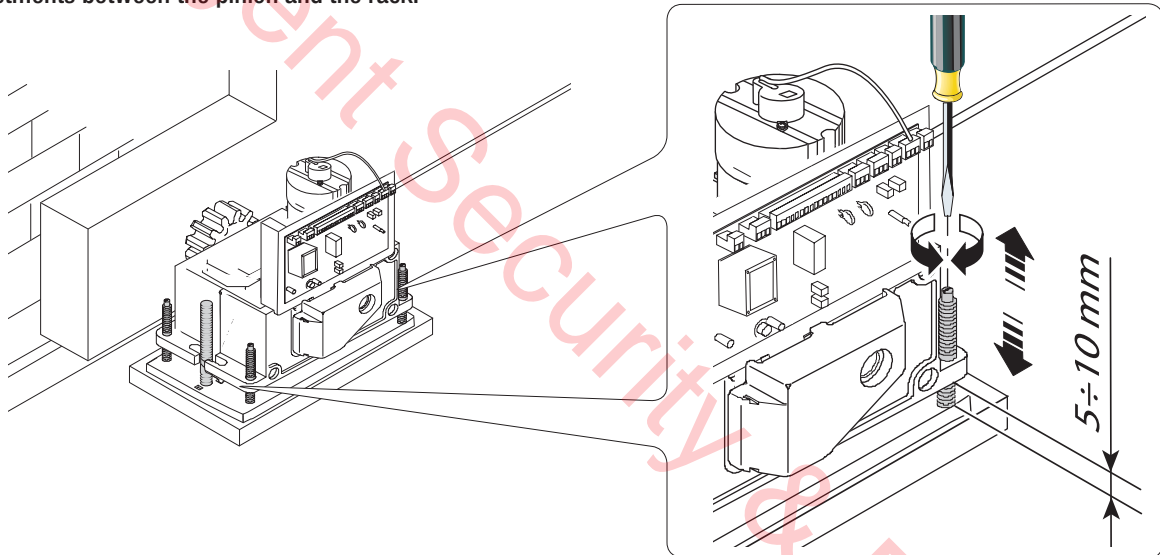

- The following illustrations for the securing the rack, are just examples of applications. It is up to the installer to choose the best solution.

Releasing the gearmotor (see paragraph on manual release). Rest the rack on the gearmotor pinion.

Weld or secure the rack to the gate along its entire length.

To assemble the rack modules, use an excess piece of rack and place it under the joining point, then block it using two C-clamps.

Note: if a rack is already in place, then just adjust the pinion-to-rack distance.

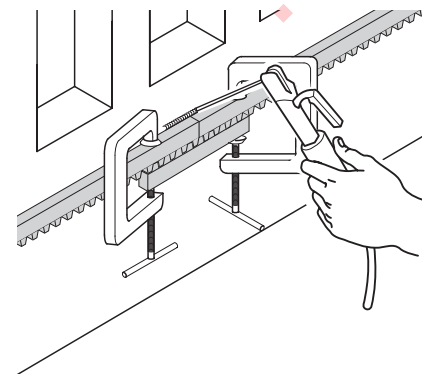
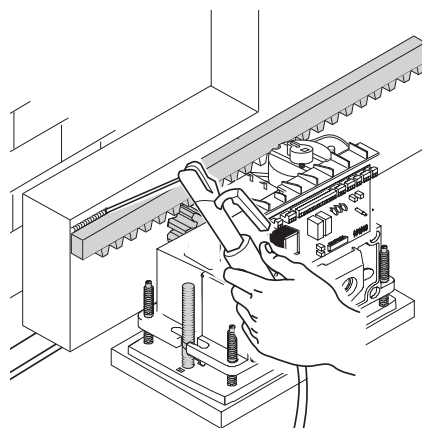
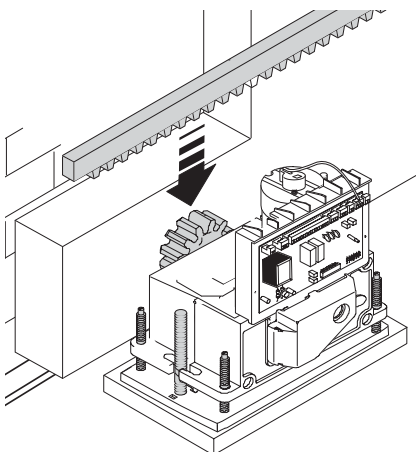

- Open and close the gate manually and register the pinion-to-rack distance using the threaded steel-levelling feet (for vertical adjusting) and the slotted holes (horizontal adjusting). This prevents the weight of the gate from bearing on the operator.

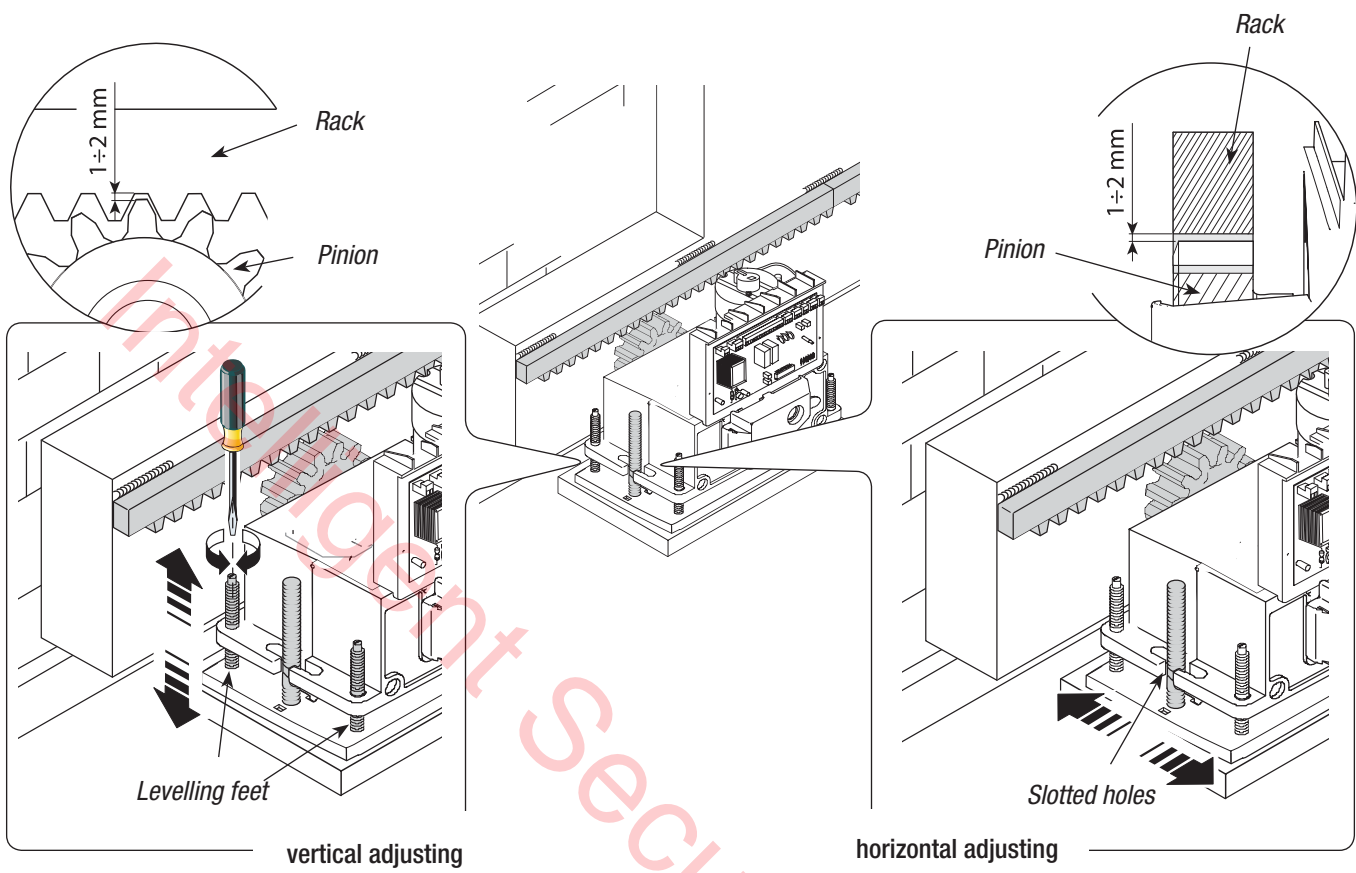

Once adjustments are finished, secure the assembly using the nuts and washers. Insert the cover after performing the adjustments and settings on the electronic card.

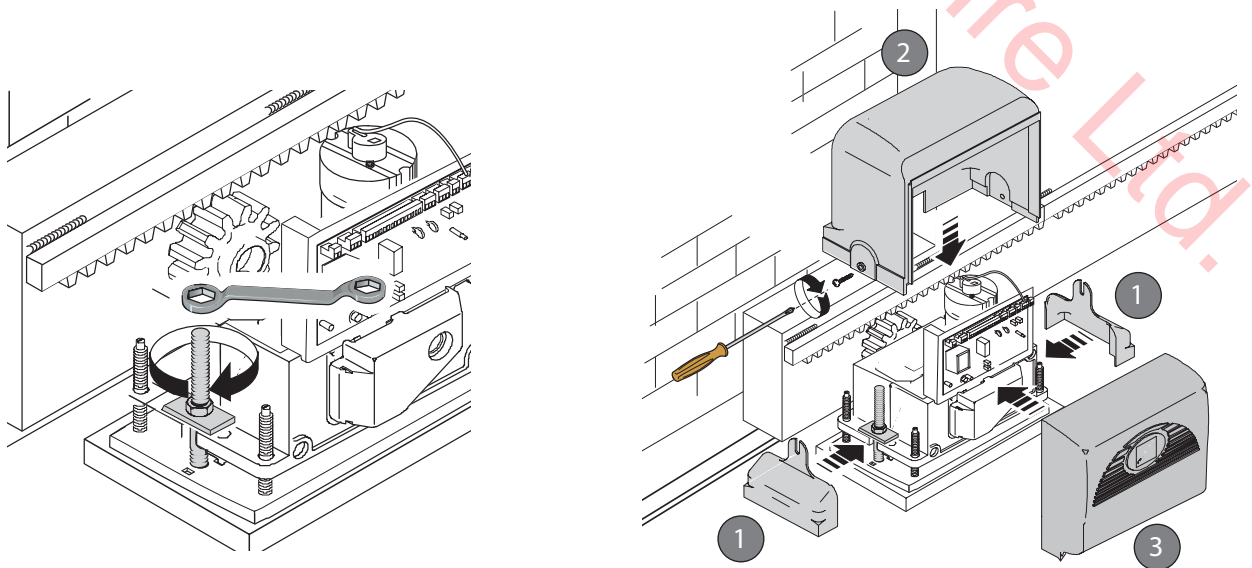

## 5.6 Mounting the endstop fins

Place the endstop fins onto the rack and secure them using a 3 mm Allen wrench. Their positioning limits the gate run.

**Note:** the gate should not slam against the mechanical stop, when opening or closing.

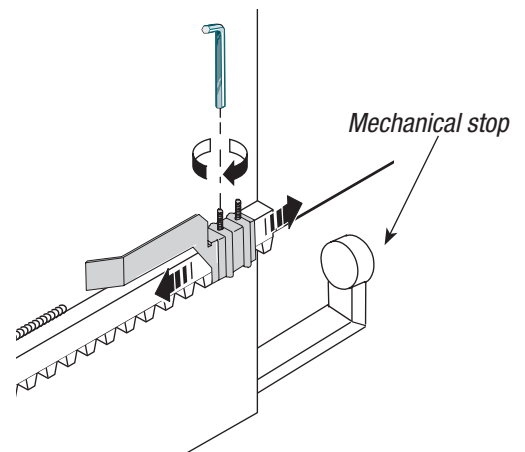
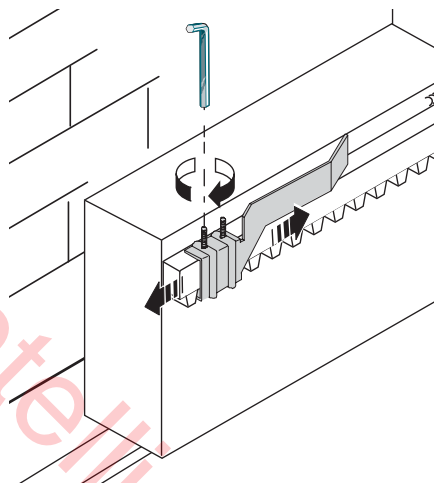

## 5.7 Manually releasing the gearmotor

- Insert the trilobed key into the lock, push it in and turn it clockwise ....

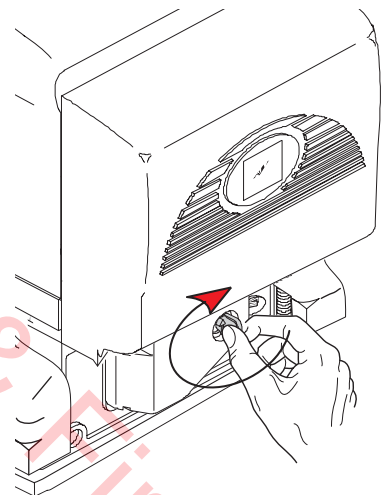
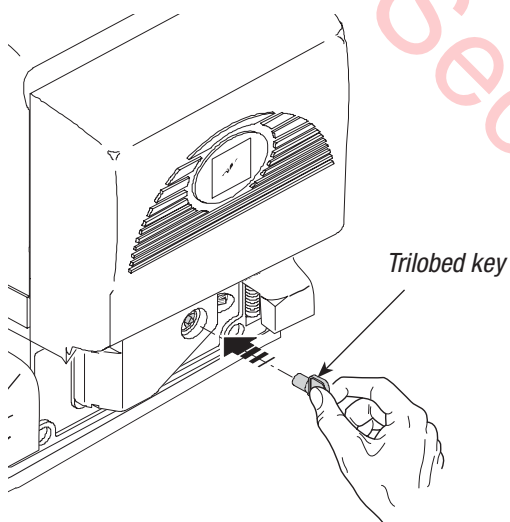

..... open the small door and turn the release handle clockwise.

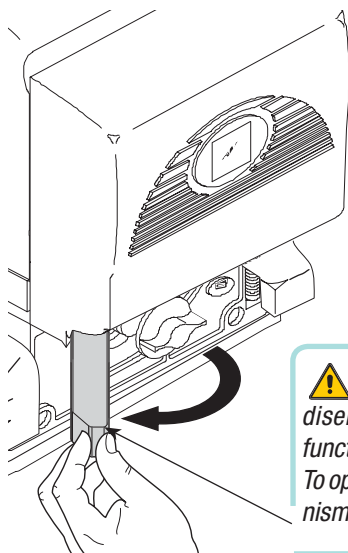

**⚠ WARNING:** opening the door will disengage the motor (i.e. it will not function).  
To operate the motor the release mechanism must be firmly fastened.

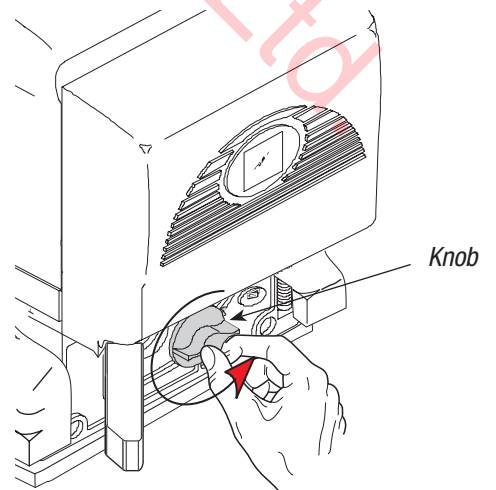

## 6 Control board

### 6.1 General description

Use 230V A.C. to power the electronic card using the L-N terminals, at a max 50/60Hz frequency.

Use 24V to power the command devices and accessories. Careful! The accessories cannot exceed 20W of overall power.

The photocells may be set up for re-opening during closing (2-C1), partial stop, total stop and obstacle detection when motor is stopped.

Note: when a normally closed safety contact (i.e. 2-C1, 2-C3 or 1-2) is opened, the signalling LED starts to flash (ref. point 11, main components).

The optical reader inverts the gate's direction of travel when it detects an obstacle during its opening and/or closing movement.

Warning: after 3 obstacle detections, the gate stops when in opening-mode and excludes automatic-closing mode; to regain movement press the command button or use the remote control.

All connections are protected by quick-fuses – see table.

The card handles the following functions:

- Automatic closing after an opening command;
- Warning light pre-flashing;
- Obstacle detection when gate is still at any point;

The following command modes are possible:

- Opening/closing;
- Opening/closing in maintained action mode;
- partial opening;
- total stop.

Apposite trimmers regulate:

- The automatic closing's running time;
- The partial opening;

**⚠ Warning!** Before acting on the machinery, cut off the main power supply and disconnect any emergency batteries.

#### TECHNICAL INFORMATION

Power supply	230V - 50/60 Hz
Maximum power allowed	200 W (BX74) 300 W (BX78)
Absorption at rest	2,6A (BX74) 2,4A (BX78)
Max power of 24V accessories	20 W

#### FUSE TABLE

To protect:	fuse:
Control board (line)	5A-F
Accessories	1A-F
Command devices	630mA-F

### 6.2 Main components

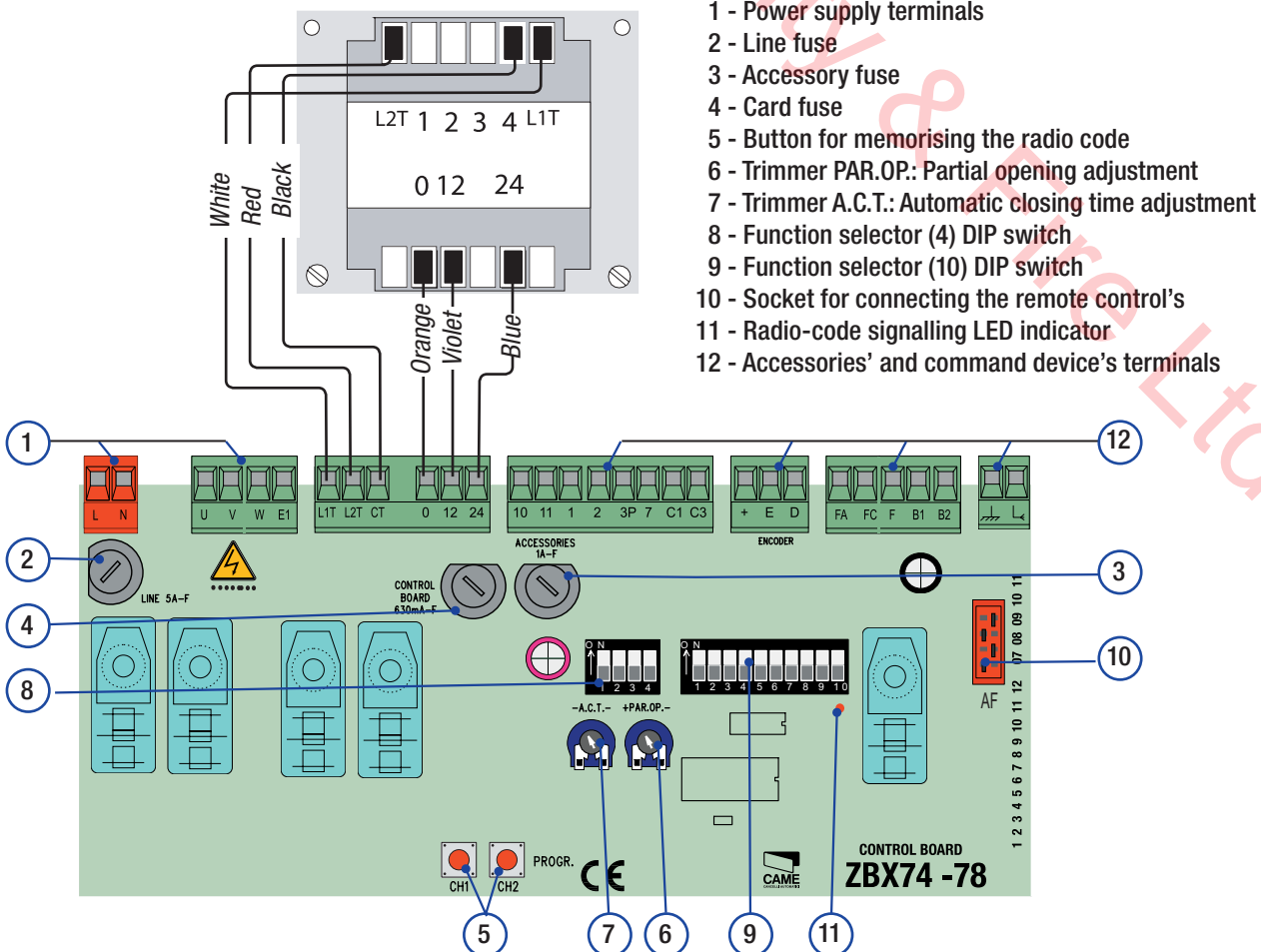

## 6.3 Electrical connections

### Gearmotor, endstop and encoder

Description of the standard electrical connections for left-hand installations

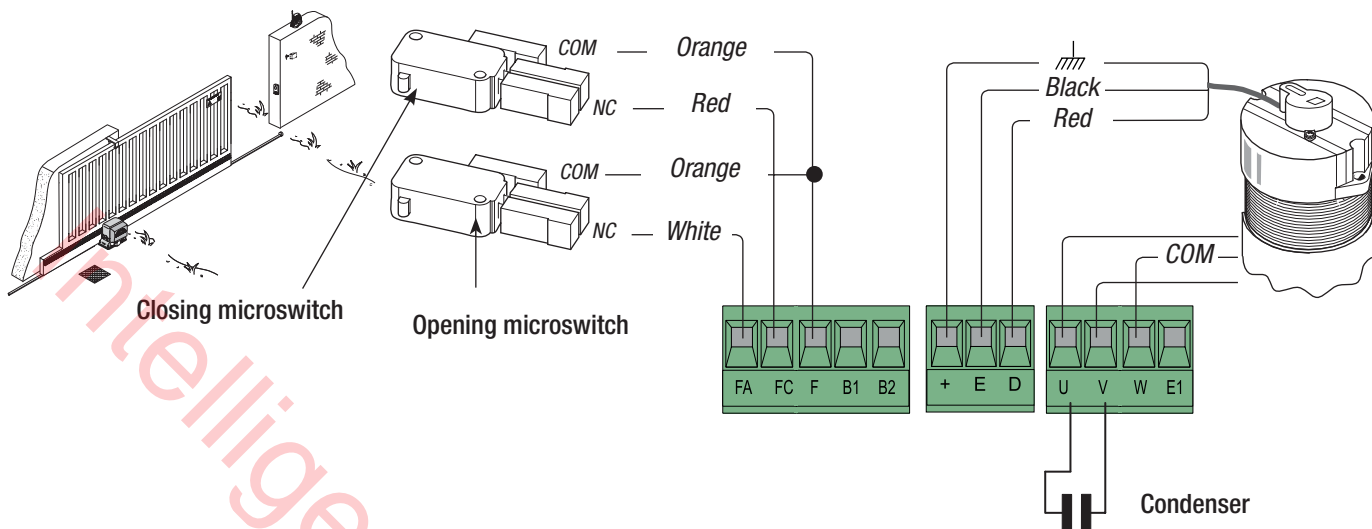

Modifications to the electrical connections for right-hand installations

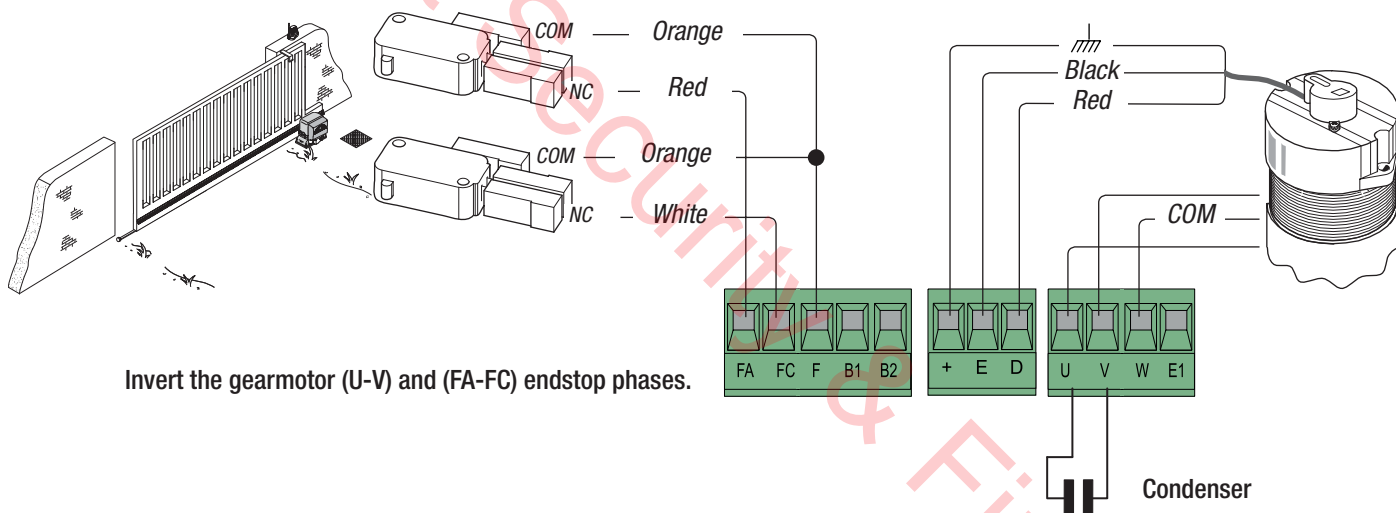

### Power supply for accessories

Cable lug with bolt and washer for connecting to earth.

Terminals for powering the following accessories:  
- 24V A.C. Maximum allowed power: 35W

230V (a.c.) Power, 50/60Hz frequency

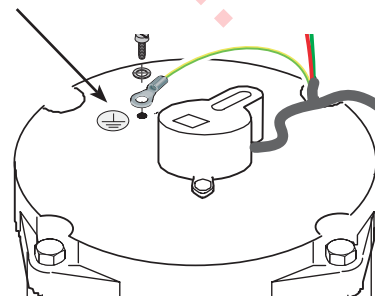
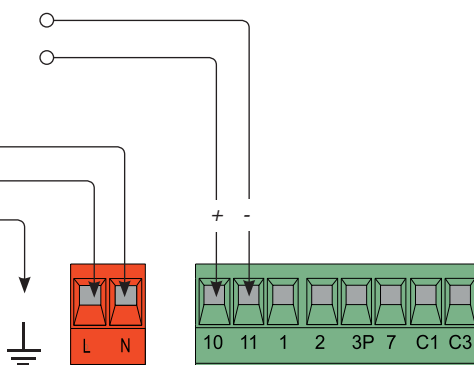

## Warning devices

### Movement flashing light (Contact range: 230V – 25W max)

- Flashes during the gate's opening and closing phases.

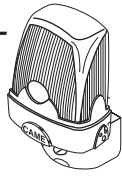

### Cycle lamp: (contact rating: 230V – 60W max.)

It lights up the driving area and stays on from the moment the gate begins to open until it is fully closed (including the automatic closing time). If automatic closing is not activated, the lamp stays on only during movement. Set DIP 1 and 6 switch to ON.

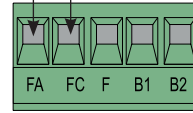
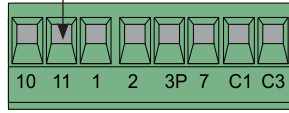
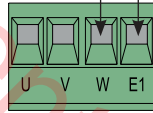

### Open-gate status light (contact range: 24V – 3W max)

- Signal that gate is open; turns off when gate is closed.



### Close-gate status light (contact range: 24V – 3W max)

- Signal that gate is close; turns off when gate is open.



## Command and control devices

### Stop button (N.C. contact)

- Gate stop button. Excludes automatic closing. For motion to resume, press the command button or the remote control button.

N.B.: If unused, set DIP 9 switch to ON.

### Key selector and/or partial opening button (N.O. contact)

- Partial gate opening for pedestrian access.

### Key selector and/or command button (N.O. contact)

- Gate opening and closing command. By pressing the button or turning the selector key, the gate inverts its movement or stops depending on which the settings on the DIP switches.

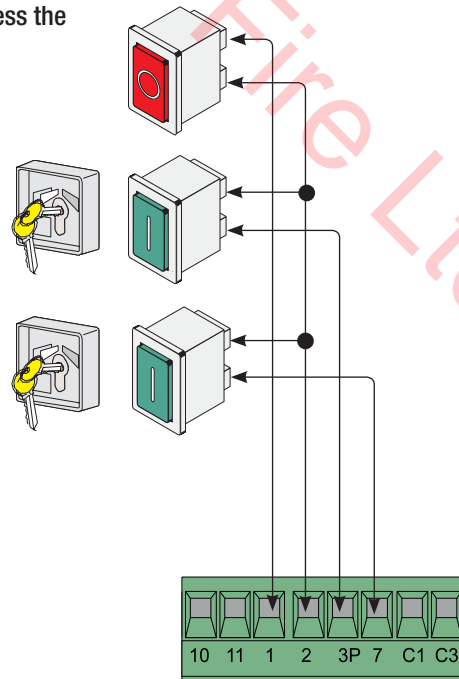

«partial stop» (N.C.) contact

- Input for EN 12978 standard-compliant safety devices such as photocells. Gate stops if moving and automatically shuts (if this functions has been selected).

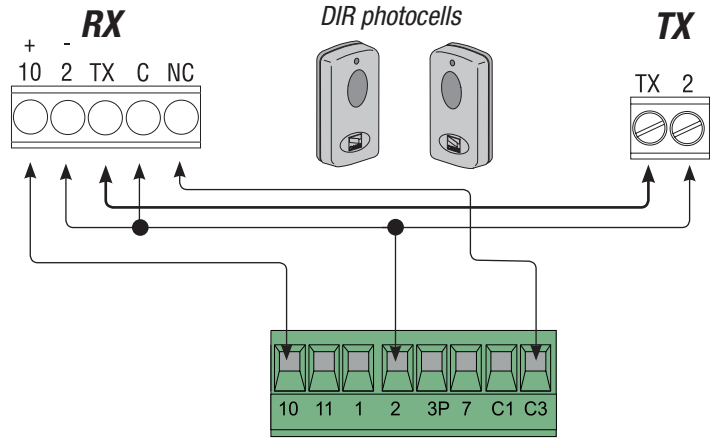

(N.C.) contact for «re-open during closing phase»

- Input for EN 12978 standard-compliant safety devices such as photocells. If contact is opened, while gate is closing, the gate inverts its direction.

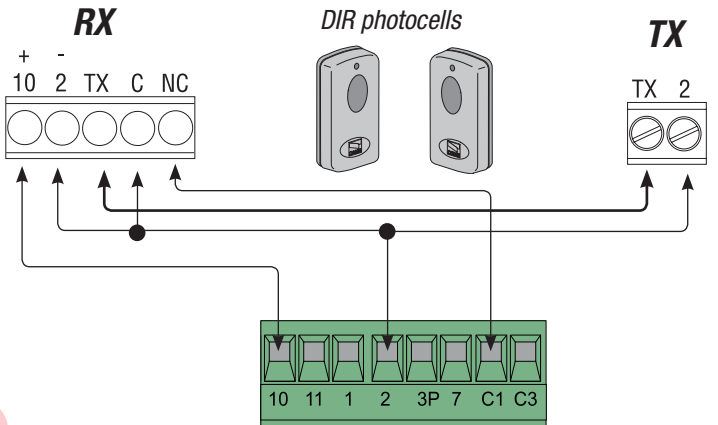

«Partial stop» (N.C.) contact

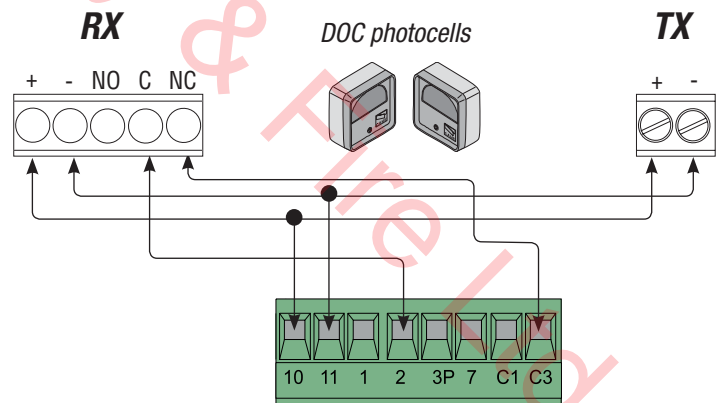

«Open while closing» (N.C.) contact

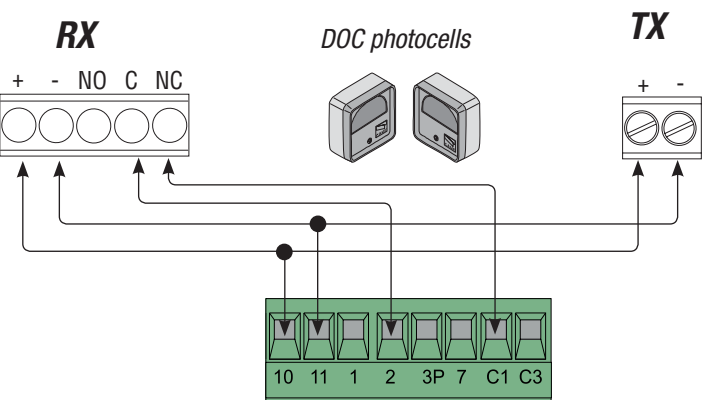

Intelligent Security & Fire

## 6.4 Function selector (dip-switch)

DIP-SWITCH 4

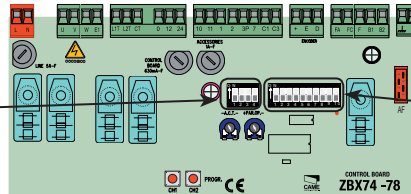

DIP-SWITCH 10



### DIP-SWITCH 10

- 1 ON - **Automatic Closing** - The automatic closing timer activates at the end of the opening gate run. The pre-set time is adjustable, and is in any case conditioned by the activation of any safety devices, and does not activate after a total safety "stop" or during a blackout.
- 2 ON - **"Open-stop-close-stop"** function with [2-7] button and radio transmitter (fitted with inserted radiofrequency card).
- 2 OFF - **"Open-close"** function with [2-7] button and radio transmitter ((fitted with inserted radiofrequency card).
- 3 ON - **"Open only"** function with radio transmitter ((fitted with inserted radiofrequency card).
- 4 ON - **Maintained action** - The gate works by keeping button pressed (one 2-3P opening button , and one 2-7 closing button).
- 5 ON - **Pre-Opening and closing flasher** - Following and opening and closing command, the flasher connected to [W-E1], flashes for 5 seconds before motion begins.
- 6 ON - **Obstacle detected** - When motor is stopped (gate closed or after a total stop command) it prevents any movement if safety devices, such as photocells, detect any obstacles.
- 7 OFF - **Opening during closing** - If the photocells detect an obstacle during gate's closing, gate motion is inverted until fully opened; connect the safety device to terminals [2-C1]; if unused, set DIP switch to ON.
- 8 OFF - **Partial stop** - Gate stop when obstacle is detected by the safety device; once obstacle is removed, the gate remains still or closes if automatic closing is activated. Connect the safety device to terminal [2-C3]; if unused, set the DIP switch to ON.
- 9 OFF - **Total stop** - This function stops the gate and then excludes any automatic closing cycle; to set in motion again, use either the keypad or transmitter. Insert the safety device in [1-2]; If unused, set DIP switch to ON.
- 10 OFF Limit switch slowing activated

### DIP-SWITCH 4

- 1 ON - **Closing only** – with command device connected on contact 2-7 (1 OFF – deactivated)
- 1 OFF - **Open-close** – with command device connected on 2-7 (see 10-way Dip Switch 2 of the function selector) (1 ON – deactivated).
- 2 ON - **Only opening** – with command device connected on contact 2-3P (2 OFF – deactivated).
- 2 OFF - **Partial opening** – with command device connected on contact 2-3P (2 ON – deactivated).
- 3 ON - **Optical reader deactivated**; (3 OFF –activated); to program deceleration you need to activated the optical reader.
- 4 ON - disconnected

**NOTE:** make selections when motor is stopped and in the closed position.

## 6.5 Settings

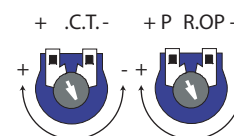
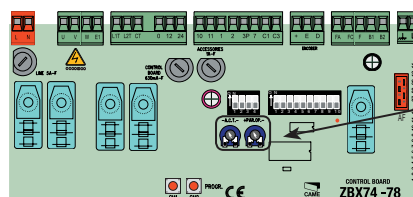

**Trimmer A.C.T.** =Sets the waiting time while open. Once this time has elapsed, closing automatically takes place. The waiting time may be set from 1 to 120 seconds.

**Trimmer PAR.OP.** = Sets the gate's partial opening. By pushing the partial opening button connected at 2-3P, the gate will open for a set time between 0 and 16 seconds.

## 6.6 Programming decelerations

So as to fully meet the compliance requirements established by European Standards EN 12445 and EN 12453 on matters concerning maximum impact forces, BX-74/78 is set up for deceleration at 50 cm from the opening and closing endpoints. When installing all you need to do is program the gate operation as follows:

Before proceeding, set all the DIP SWITCHES to OFF (10-way Dip Switches)

- Set Dip Switch **4, 7, 8 and 9** to **ON** (10-way Dip Switch) and **Dip Switch 3 e** to **OFF** (4-way dip-switch, optical reader);
- press CH1** until the red LED starts flashing (after about 3 secs). After which, the gate will fully open and close.
- when the **led stays on**, this means the programming procedure is finished;
- reset the DIP SWITCHES to the previous setting, which is determined by the selection of functions (see parag. 6.4 on p. 14).

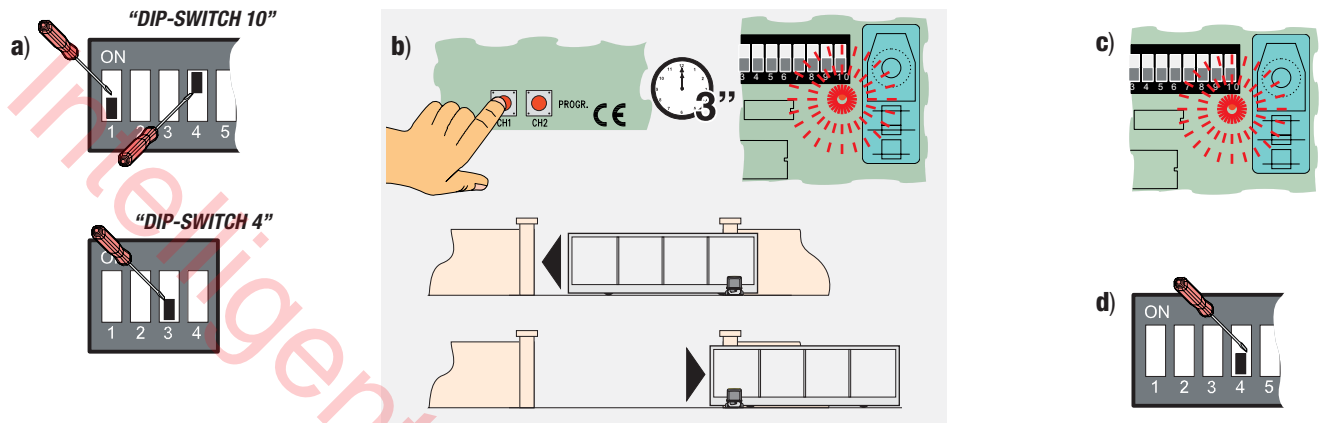

The **decelerated gate operation speed** may be changed by simply pressing **CH1 (to reduce it)** or **CH2 (to increase it)** while the operator is decelerating.

*NOTE: When the card is initially activated, the PROG LED will flash rapidly, and in so doing signalling that the card is not programmed; once programmed the LED will remain off.*

To exclude decelerations, set Dip Switch 10 to ON.

If power is cut off during gate closure operation and decelerations have been activated, once the power comes back on, the operator always and for safety reasons, will perform a full, decelerated opening and closing cycle.

## 6.7 Modifying the Re-closing Partial Stop during opening

With BX-74/78 you can change the function of the Re-closing Partial Stop during opening, which is connected on 2-C3.

To activate it, do the following:

- Set Dip Switch 1 and 4 on ON;
- press CH1: the red LED will start to flash;
- when the LED stays lit up (after about 5 secs) this means that the procedure is finished;
- reset the DIP SWITCHES to the previous setting, which is determined by the selection of functions (see parag. 6.4 on p. 14).

N.B.: to go back to the default selection, follow the same procedure but press CH2.

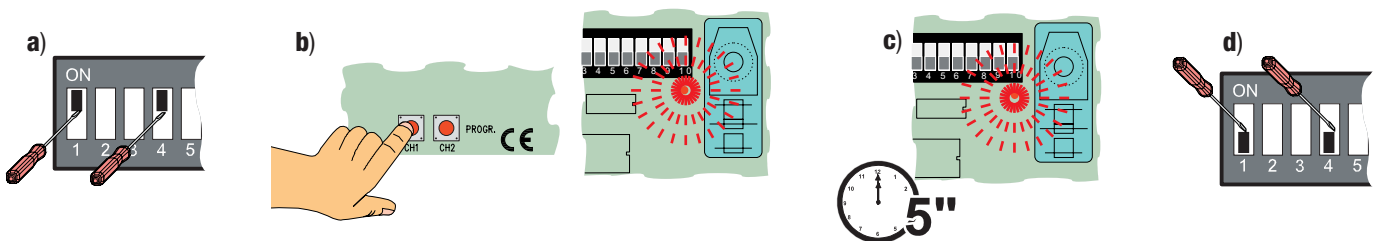
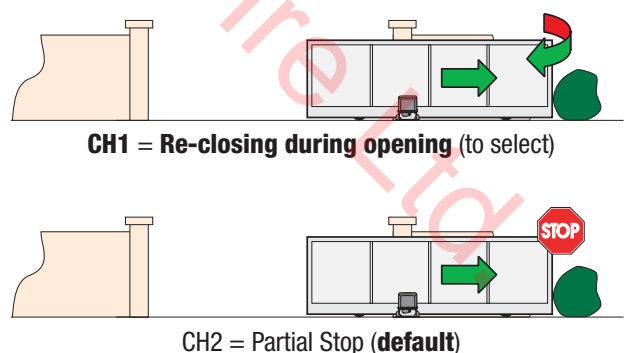

### 6.8 Motor torque limiter

To vary the motor torque, move the shown faston (the one with the black wire) to one of the 4 positions: 1 min – 4 max.

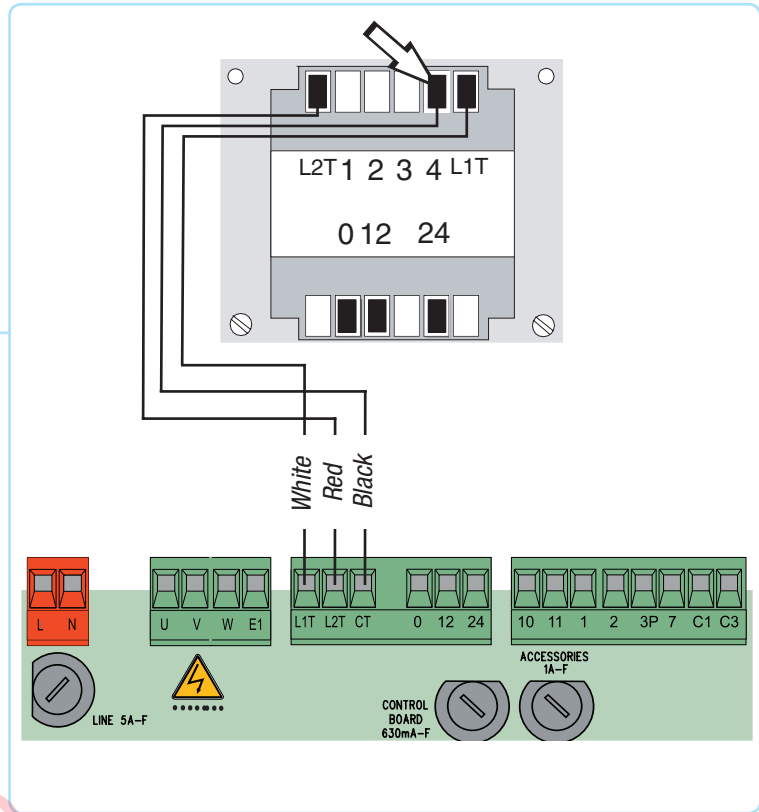
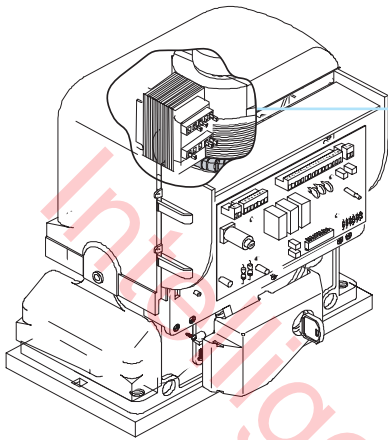

### 7 Activating the radio command

#### Antenna

Possible output of the radio receiver's second channel (N.O. socket).  
Socket rating: 5A-24V (d.c.).

Connect the antenna's RG58 cable to the opposite terminals.

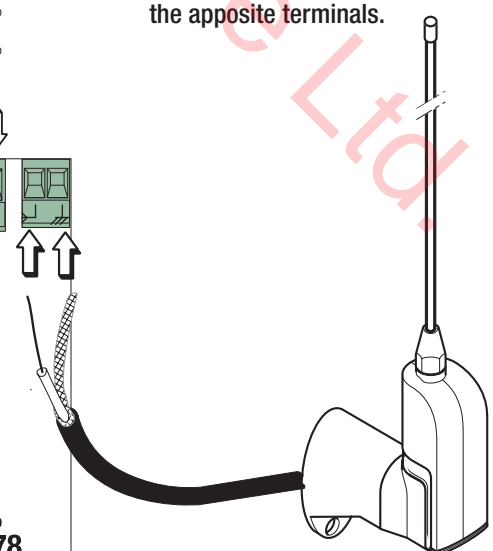
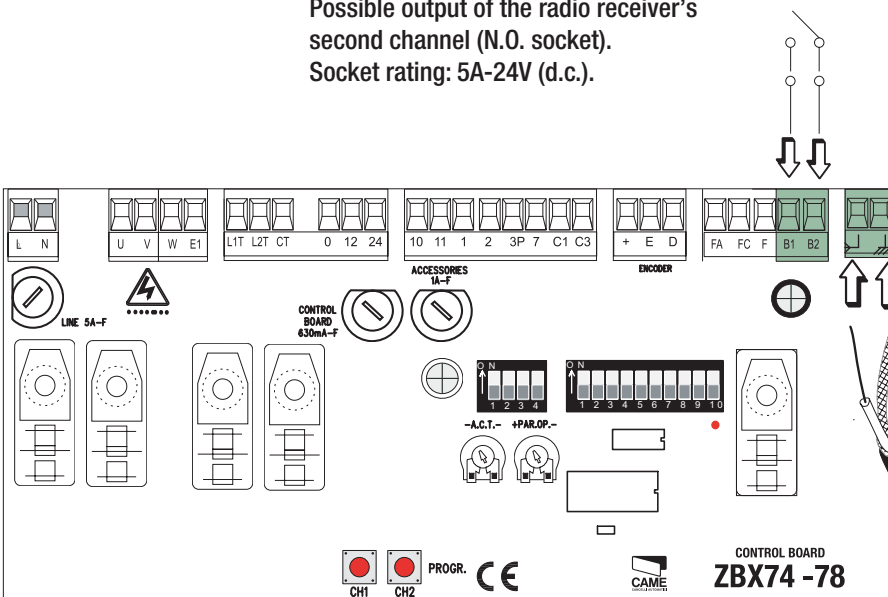

## Radiofrequency card

Insert the radio frequency card into the electronic card **AFTER DISCONNECTING THE POWER** (and disconnecting any batteries).  
**N.B.:** the electronic card picks up the radiofrequency card on when it is running on power

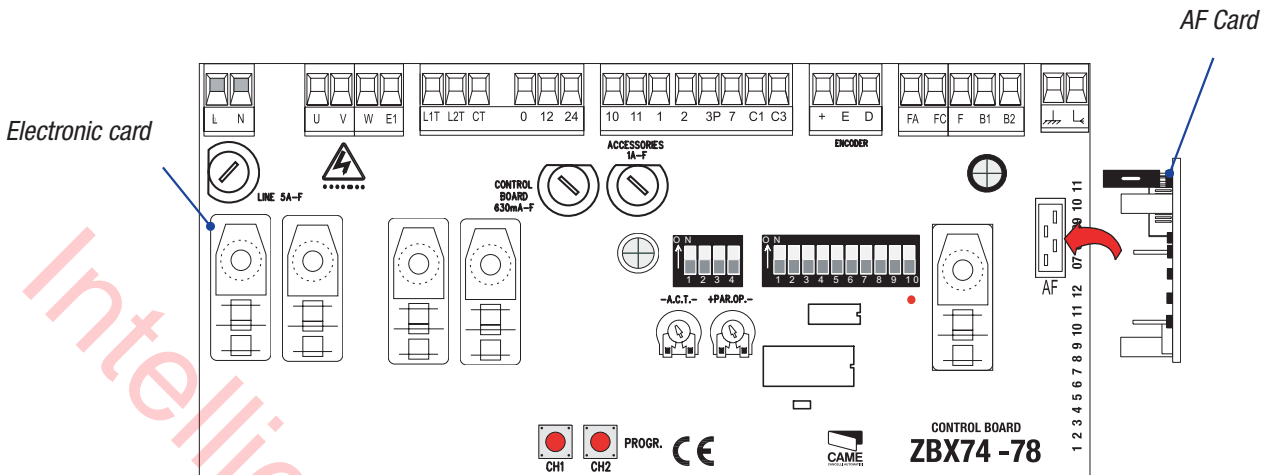

## Transmitters

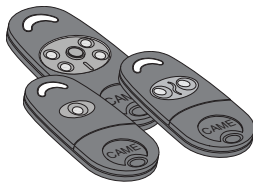

**ATOMO**  
 AT01 • AT02  
 AT04

See instruction sheet *in AF43SR radiofrequency card box*

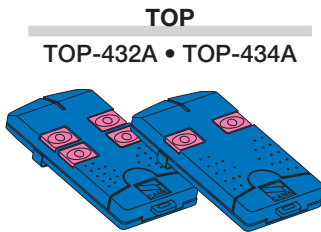

**TOP**  
 TOP-432A • TOP-434A

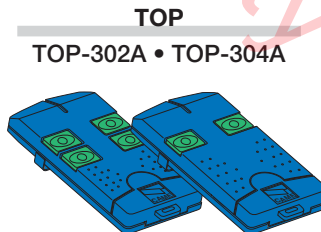

**TOP**  
 TOP-302A • TOP-304A

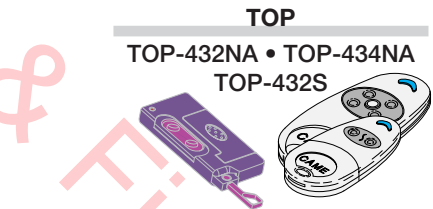

**TOP**  
 TOP-432NA • TOP-434NA  
 TOP-432S

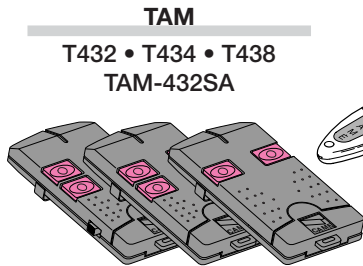

**TAM**  
 T432 • T434 • T438  
 TAM-432SA

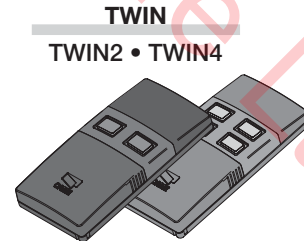

**TWIN**  
 TWIN2 • TWIN4

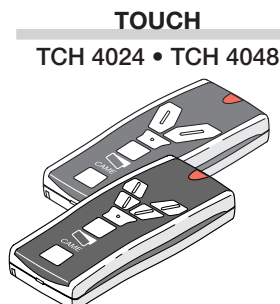

**TOUCH**  
 TCH 4024 • TCH 4048

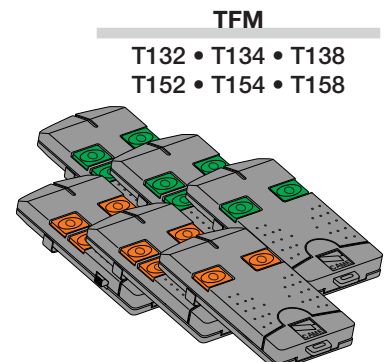

**TFM**  
 T132 • T134 • T138  
 T152 • T154 • T158

See instructions on packaging

- Keep the CH1 button on the electronic card pressed. The led flashes.

**CH1** = Channel for direct command to a function of the gearmotor's card, ("open only"/"open-close-invert" or "open-stop-close-stop" vommand, depending on the choice made on DIP switches 2 and 3).

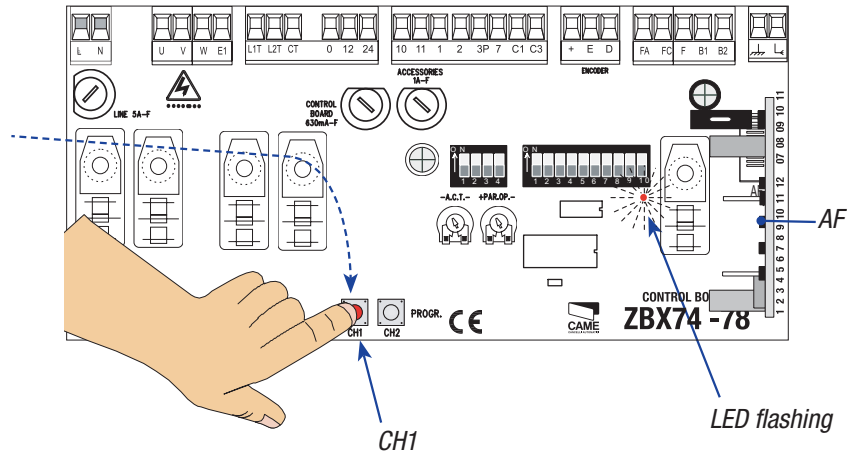

- Press the transmitter button you wish to memorise. The LED will stay on to show memorisation has been successful.

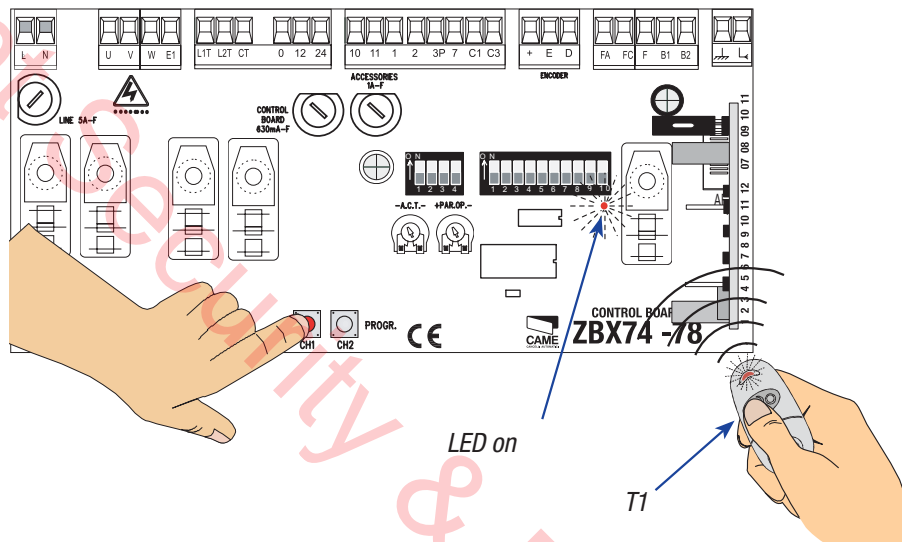

- Repeat the procedure for the "CH2" button associating this to another button on the transmitter.

**CH2** = Channel for direct command to an auxiliary device or for the control of two paired motors, connected to B1-B2.

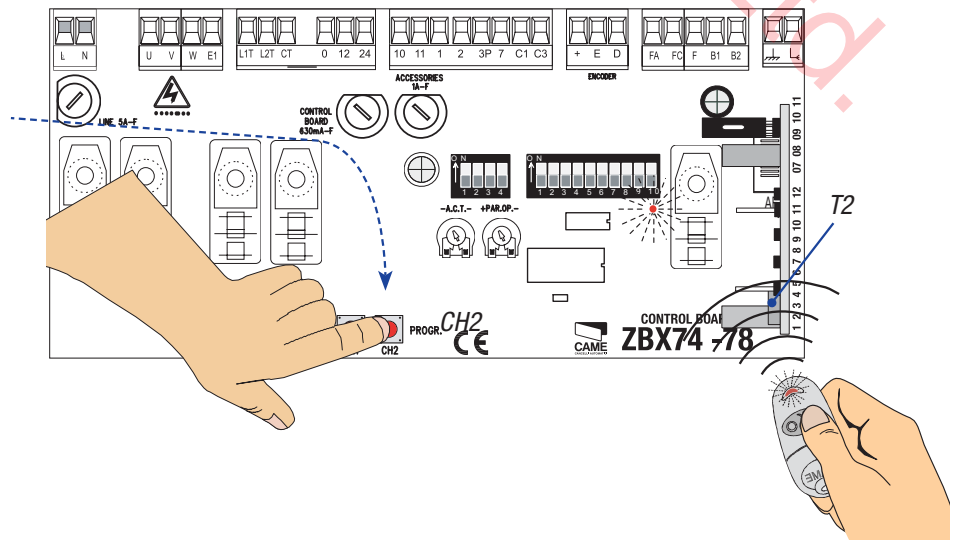

## 8 Connecting two joined motors with a single command

1) Coordinate the direction of travel of geared motors "A" and "B", by modifying the rotation of motor "B" (see p. 11 geared motor-endstop connection)

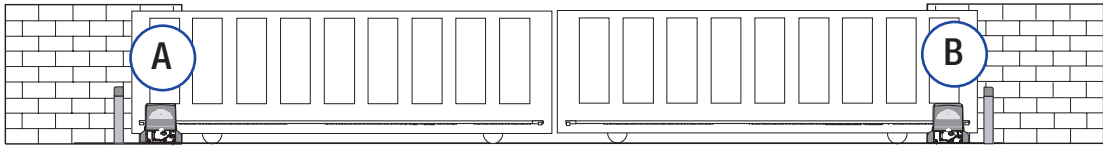

2) Carry out the electrical connections on the geared-motor "A" command card as per paragraph 6.3 electrical connections.

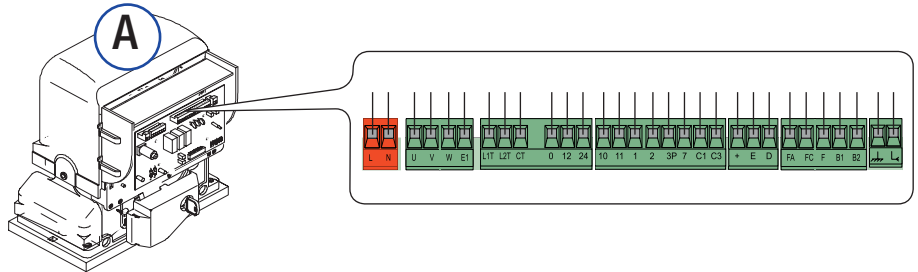

3) On both cards, carry out the same settings and activate the same functions (Dip Switches)

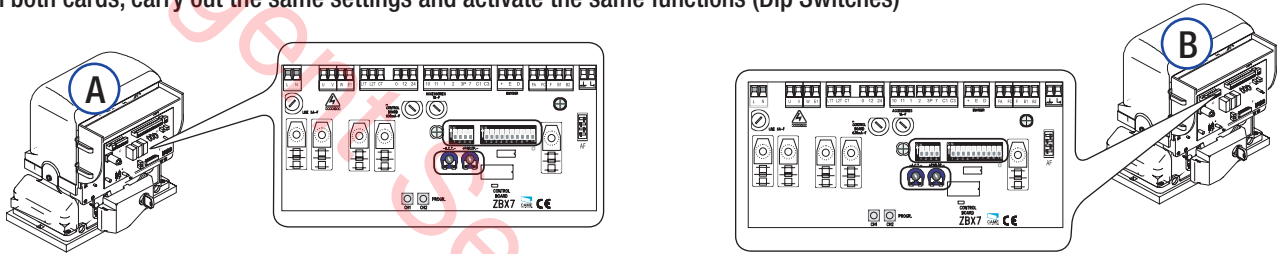

4) Carry out the connections between the two command cards as per the figure.

Note: the (2-3P) partial opening button needs to be connected to the command card's terminal board of the motor in question (motor A for opening left-wards, and B for opening right-wards).

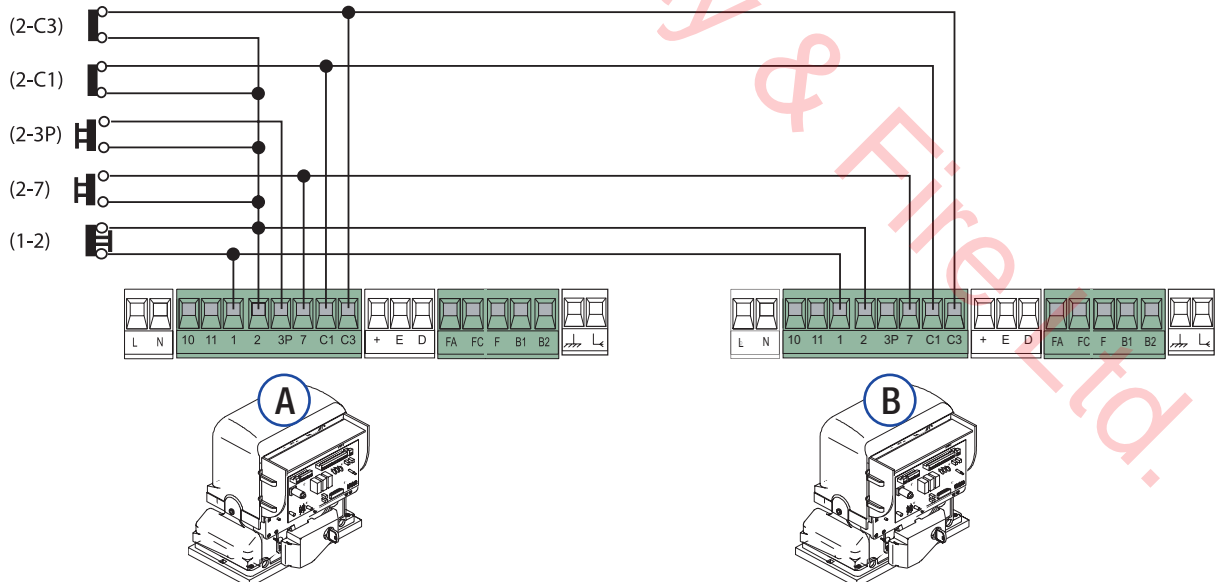

5) On the geared motor A's command card, insert the AF radio card. Activate the radio command, using the CH2 channel (see chapter 7). After memorising the code, connect contacts B1 and B2 on contacts 2 and 7. On both cards, select the type of command (see Dip-Switches 2 and 3).

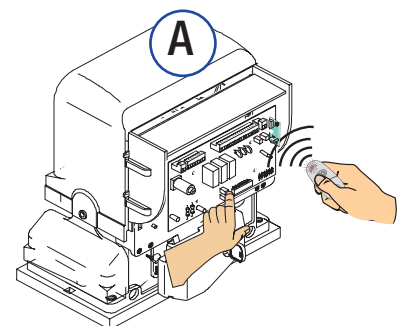

## 9 Safety instructions

### Important safety instructions

This product must only be employed for its originally intended use. Any other use is wrong and potentially dangerous. The manufacturer cannot be held liable for any damages resulting from wrongful, erroneous or negligent uses.

Avoid working close to the hinges or other moving mechanical parts. Stay out of the opening/closing arc when operator is in motion.

Do not exercise force against the motion of the operator as this could result in potentially dangerous situations.

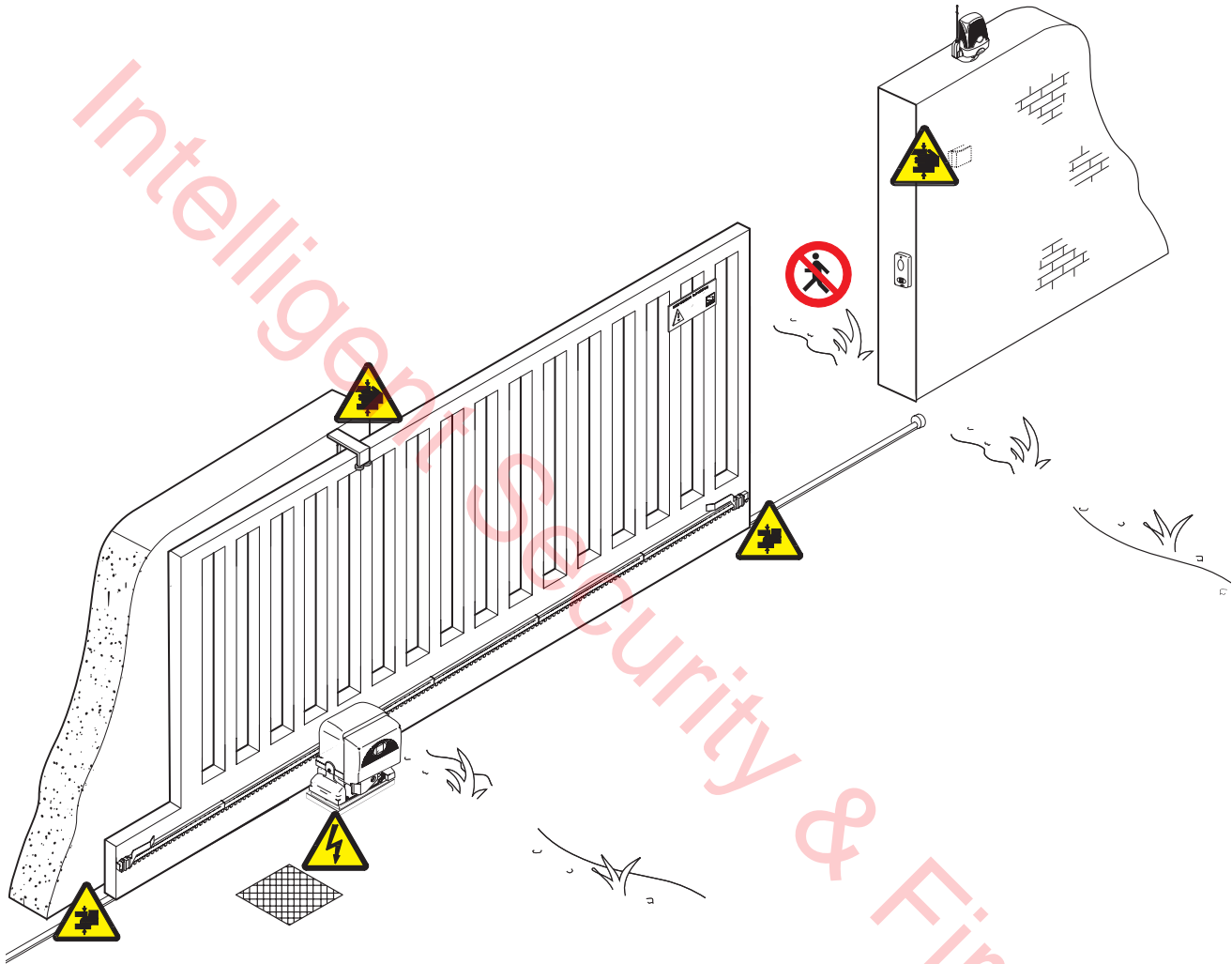

Do not allow children to play or loiter within the opening/closing arc of the operator. Keep remote controls and any other command device out the reach of children, to prevent operator from being activated by accident.

In the event of anomalous behaviour, stop using the operator immediately.



Danger of crushing hands



Danger! High voltage



Danger of crushing feet



No transit during operation

## 10 Maintenance

### 10.1 Periodic maintenance

 Periodic maintenance to be carried out by the end-user is as follows: wipe clean the glass surface of the photocells; check that the safety devices work properly; remove any obstructions.

We suggest checking the state of lubrication and tightness of the anchoring screws on the operator.

-To check the efficiency of the safety devices, move an object in front of the photocells when gate is closing. If the operator inverts the motion or stops, the photocells are working properly.

This is the only maintenance procedure to be carried out with the power source connected.

-Before performing any maintenance procedures, cut off the main power, to prevent possible accidents due to gate movement.

-To clean the photocells use a water dampened cloth. Do not use solvents or other chemical products which may ruin the devices.

-In the event of any strange vibrations or squeaking, lubricate the joints with grease, as shown in the diagram.

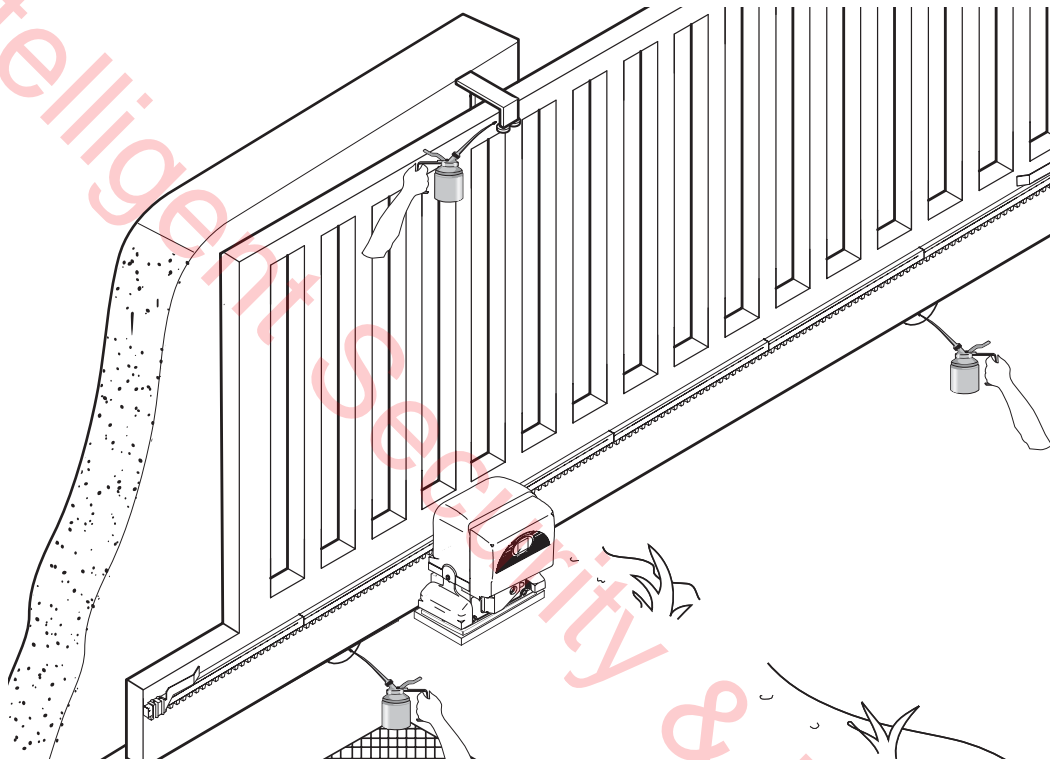

-Make sure there are no plants within the photocell's beam, and that the gate motion is free of any obstacles.

### 10.2 Trouble shooting

MALFUNCTIONS	POSSIBLE CAUSES	CHECK AND REMEDIES
The gate will not open nor close	<ul style="list-style-type: none"> <li>• There is no power</li> <li>• The gearmotor is in release mode and the release door is open</li> <li>• The transmitter's batteries are run down</li> <li>• The transmitter is broken</li> <li>• The stop button is either stuck or broken</li> <li>• The opening/closing button or the key selector are stuck</li> <li>• Photocells in partial stop mode</li> </ul>	<ul style="list-style-type: none"> <li>• Check that the power is up</li> <li>• Call assistance</li> <li>• Replace batteries</li> <li>• Call assistance</li> <li>• Call assistance</li> <li>• Call assistance</li> <li>• Call assistance</li> </ul>
The gate opens but will not close	<ul style="list-style-type: none"> <li>• The photocells are engaged</li> <li>• Sensitive edge triggered</li> </ul>	<ul style="list-style-type: none"> <li>• Check that photocells are clean and in good working order</li> <li>• Call assistance</li> </ul>
The gate closes but will not open	<ul style="list-style-type: none"> <li>• Sensitive edge triggered</li> </ul>	<ul style="list-style-type: none"> <li>• Call assistance</li> </ul>
The flasher does not work	<ul style="list-style-type: none"> <li>• The bulb is burnt</li> </ul>	<ul style="list-style-type: none"> <li>• Call assistance</li> </ul>



Installer's stamp	Operator name
	Date of job
	Technician's signature
	Requester's signature
Job performed _____	

Installer's stamp	Operator name
	Date of job
	Technician's signature
	Requester's signature
Job performed _____	

## 11 Phasing out and disposal

 CAME CANCELLI AUTOMATICI S.p.A. employs a UNI EN ISO 14001 certified and compliant environmental protection system at its plants, to ensure that environmental safeguarding.

We ask you to keep protecting the environment, as CAME deems it to be one of the fundamental points of its market operations strategies, by simply following these brief guidelines when disposing:

### DISPOSING THE PACKING MATERIALS

The packing components (cardboard, plastic, etc.) are solid urban waste and may be disposed of without any particular difficulty, by simply separating them so that they can be recycled.

Before actions it is always advisable to check the pertinent legislation where installation will take place.

**DO NOT DISPOSE OF IN NATURE!**

### DISPOSING OF THE PRODUCT

Our products are made using different types of materials. The majority of them (aluminium, plastic, iron, electric cables) can be considered to be solid urban waste. They may be recycled at authorised firms.

Other components (electrical circuit board, remote control batteries etc.) may contain hazardous waste.

They must, thus, be removed and turned in to licensed firms for their disposal.

Before acting always check the local laws on the matter.

**DO NOT DISPOSE OF IN NATURE!**

## 12 Conformity declaration



### MANUFACTURER'S DECLARATION OF CONFORMITY

Pursuant annex II B of the Machinery Directive 98/37/EC



CAME Cancelli Automatici S.p.A.  
via Martiri della Libertà, 15  
31030 Dosson di Casier - Treviso - ITALY  
tel (+39) 0422 4940 - fax (+39) 0422 4941  
internet: www.came.it - e-mail: info@came.it

#### IMPORTANT WARNING!

Do not use the equipment specified here above, before completing the full installation  
In full compliance with the Machinery Directive 98/37/EC

Declares under its own responsibility that the equipments for automatic garage doors and gates listed below:

**BX-74 / BX-78**

... comply with the National Law related to the following European Directives and to the applicable parts of the following Standards.

98/37/CE - 98/79/CE	MACHINERY DIRECTIVE
98/336/CEE - 92/31/CEE	ELECTROMAGNETIC COMPATIBILITY DIRECTIVE
73/23/CEE - 93/68/CE	LOW VOLTAGE DIRECTIVE
89/106/CEE	CONSTRUCTION PRODUCTS DIRECTIVE

MANAGING DIRECTOR  
Mr. Andrea Menuzzo

EN 13241-1	EN 12635	EN 61000-6-2
EN 12453	EN 12978	EN 61000-6-3
EN 12445	EN 60335-1	EN 60204-1

Reference code to request a true copy of the original: **DDF B EN B001a**

**CAME France S.a.**  
7, Rue Des Haras  
Z.i. Des Hautes Patures  
92737 **Nanterre Cedex** - FRANCE  
☎ (+33) 1 46 13 05 05  
✉ (+33) 1 46 13 05 00

**CAME Gmbh Seefeld**  
Akazienstrasse, 9  
16356 **Seefeld**  
Bei Berlin - DEUTSCHLAND  
☎ (+49) 33 3988390  
✉ (+49) 33 39883985

**CAME Automatismes S.a.**  
3, Rue Odette Jasse  
13015 **Marseille** - FRANCE  
☎ (+33) 4 95 06 33 70  
✉ (+33) 4 91 60 69 05

**CAME Gmbh**  
Kornwestheimer Str. 37  
70825 **Korntal**  
Munchingen Bei Stuttgart - DEUTSCHLAND  
☎ (+49) 71 5037830  
✉ (+49) 71 50378383

**CAME Automatismos S.a.**  
C/juan De Mariana, N. 17-local  
28045 **Madrid** - SPAIN  
☎ (+34) 91 52 85 009  
✉ (+34) 91 46 85 442

**CAME Americas Automation Llc**  
1560 Sawgrass Corporate Pkwy, 4th Floor  
**Sunrise, FL 33323** - U.S.A  
☎ (+1) 305 433 3307  
✉ (+1) 305 396 3331

**CAME Automatismos Catalunya S.a.**  
Pi. Moli Dels Frares N. 23 C/a  
08620 **Sant Vicenc Del Horts** - SPAIN  
☎ (+34) 93 65 67 694  
✉ (+34) 93 67 24 505

**CAME Middle East Fzco**  
Po Box 17131 Warehouse N. Be02  
South Zone - Jebel Ali Free Zone - **Dubai** - U.A.E.  
☎ (+971) 4 8860046  
✉ (+971) 4 8860048

**Paf - CAME**  
Estrada Nacional 249-4 Ao Km 4,35  
Cabra Figa - Trajouce  
2635-047 **Rio De Mouro** - PORTUGAL  
☎ (+351) 219 257 471  
✉ (+35) 219 257 485

**CAME Polska Sp.Zo.o**  
Ul. Ordona 1  
01-237 **Warszawa** - POLAND  
☎ (+48) 22 8365076  
✉ (+48) 22 8363296

**CAME United Kingdom Ltd.**  
Unit 3 Orchard Business Park  
Town Street, Sandiacre  
**Nottingham** - Ng10 5du - UNITED KINGDOM  
☎ (+44) 115 9210430  
✉ (+44) 115 9210431

**S.c. CAME Romania S.r.l.**  
B-dul Mihai Eminescu, Nr. 2, Bloc R2  
Scara A, Parter, Ap. 3  
Buftea, Judet Ilfov **Bucarest** - ROMANIA  
☎ (+40) 21 3007344  
✉ (+40) 21 3007344

**CAME Belgium Sprl**  
Zoning Ouest 7  
7860 **Lessines** - BELGIUM  
☎ (+32) 68 333014  
✉ (+32) 68 338019

**CAME Russia**  
Leningradskij Prospekt, Dom 80  
Pod'ezd 3, office 608  
125190, **Moskva** - RUSSIA  
☎ (+7) 495 937 33 07  
✉ (+7) 495 937 33 08

**CAME Cancelli Automatici S.p.a.**  
Via Martiri Della Libertà, 15  
31030 **Dosson Di Casier (Tv)**  
☎ (+39) 0422 4940  
✉ (+39) 0422 4941  
Informazioni Commerciali 800 848095  
www.came.it

**CAME Nord s.r.l.**  
Piazza Castello, 16  
20093 **Cologno Monzese (MI)**  
☎ (+39) 02 26708293  
✉ (+39) 02 25490288

**CAME Service Italia S.r.l.**  
Via Della Pace, 28  
31030 **Dosson Di Casier (Tv)**  
☎ (+39) 0422 383532  
✉ (+39) 0422 490044  
**Assistenza Tecnica 800 295830**

**CAME Sud s.r.l.**  
Via F. Imperato, 198  
Cm2 Lotto A/7  
80146 **Napoli**  
☎ (+39) 081 7524455  
✉ (+39) 081 7529109

English - Manual code: **119BU56** ver. **1.0** 01/2008 © CAME cancelli automatici s.p.a.  
The data and information reported in this installation manual are susceptible to change at any time and without obligation on CAME cancelli automatici s.p.a. to notify users.

