

**WIRE CODING FOR MONITORED VERSION**

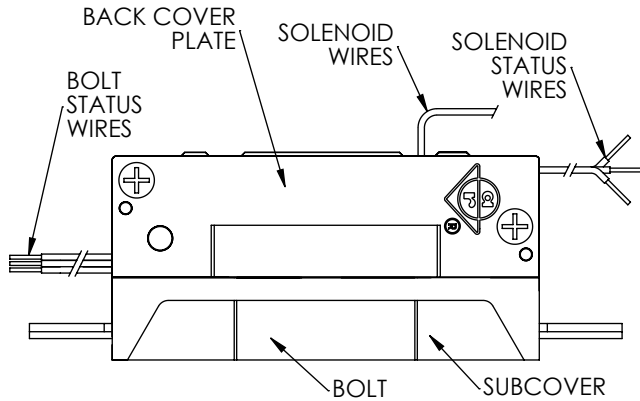

MONITOR WIRING  
 NC: RED  
 NO: WHITE  
 COMMON: BLACK

POWER INPUT WIRING  
 12VAC: YELLOW/BLACK  
 12VDC, 24VAC: RED/BLACK  
 24VDC: WHITE/BLACK

**STEP 1**

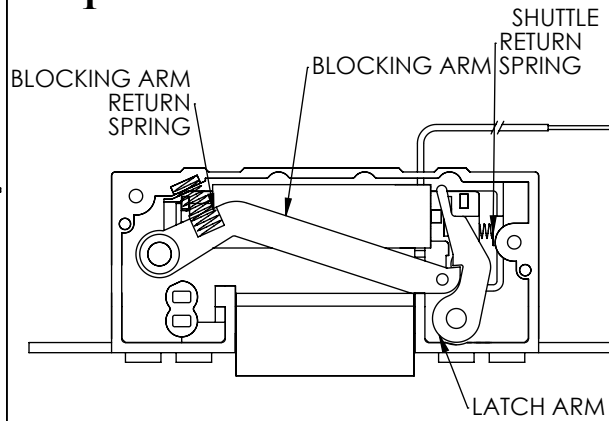

REMOVE SUBCOVER (ONE SCREW)  
 REMOVE BACK COVER PLATE (TWO SCREWS)  
 CAREFULLY REMOVE BLOCKING ARM SPRING  
 REMOVE BLOCKING ARM AND LATCH ARM

**STEP 2**

**FAIL SECURE**

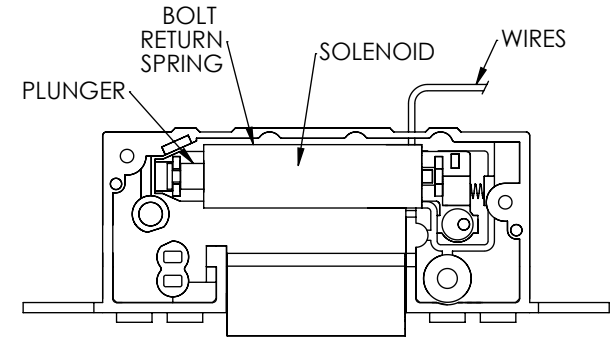

REMOVE SOLENOID

**STEP 3**

**FAIL SAFE**

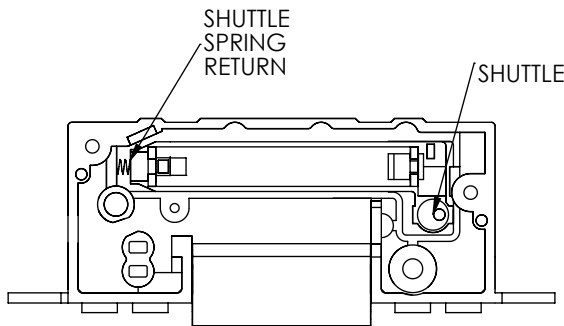

TRANSFER SHUTTLE RETURN SPRING TO OPPOSITE END OF SHUTTLE. NOTE: WHATEVER THE FUNCTION, THE SHUTTLE RETURN SPRING SHOULD ALWAYS BE AT OPPOSITE END TO THE SOLENOID PLUNGER.

**STEP 4**

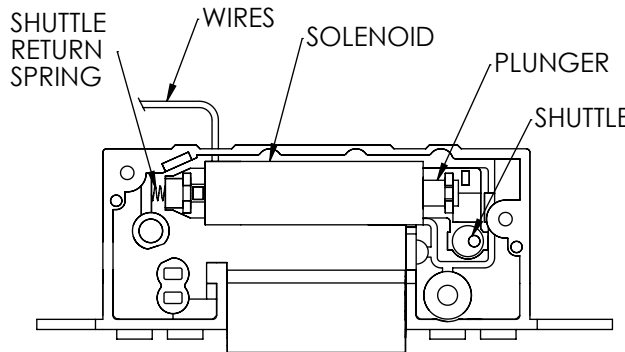

REVERSE SOLENOID AND REPLACE, ENSURING CORRECT PLACEMENT AND ALIGNMENT. WITH THE SOLENOID SEATED PROPERLY THE SHUTTLE SHOULD MOVE FREELY.

**STEP 5**

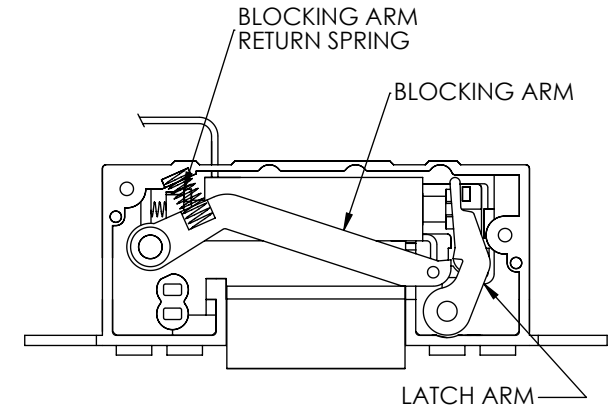

REPLACE LATCH ARM AND BLOCKING ARM (WITH SPRING)  
 REPLACE BACK COVER PLATE  
 REPLACE SUBCOVER  
 \* TEST PRIOR TO INSTALLATION\*



www.adamsrite.com  
 Phone: 800-626-7590  
 800-872-3267

Fax: 866-582-4641  
 800-232-7329

**ASSA ABLOY**

**7100 EL-STRIKE FIELD CONVERSION**

**80-0180-472**

Rev. C Ecn 11955D

**INSTALLATION INSTRUCTIONS**

Date: 07/20/12

Appvd: MP