

EN

TECHNICAL  
MANUAL

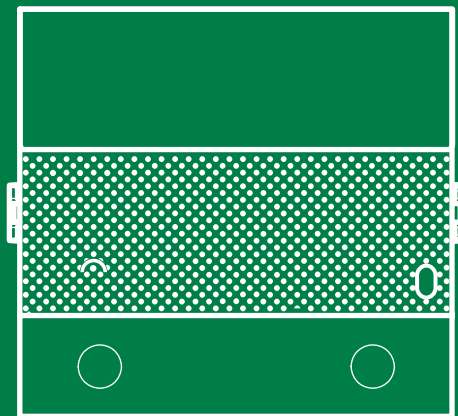

Simplebus2 Ultra audio module  
Art. UT2010

 **Comelit**<sup>®</sup>  
Passion. Technology. Design.

# Warning

## Intended use

This Comelit product has been designed and manufactured for use in the creation of audio and video communication systems in residential, commercial, industrial and public buildings.

## Installation

All activities connected to the installation of Comelit products must be carried out by qualified technical personnel, with careful observation of the indications provided in the Manuals / Instruction sheets supplied with those products.

## Wires

Disconnect the power supply before carrying out any operations on the wiring.

Use wires with a cross-section suited to the distances involved, observing the instructions provided in the system manual.

We advise against running the system wires through the same duct as power cables (230V or higher).

## Safe usage

To ensure Comelit products are used safely:

- carefully observe the indications provided in the Manuals / Instruction sheets,
- make sure the system created using Comelit products has not been tampered with / damaged.

## Maintenance

Comelit products do not require maintenance aside from routine cleaning, which should be carried out in accordance with the indications provided in the Manuals / Instruction sheets.

Any repairs must be carried out:

- for the products themselves, exclusively by **Comelit Group S.p.A.**,
- for the systems, by qualified technical personnel.

## Disclaimer

**Comelit Group S.p.A.** does not assume any responsibility for

- any purpose other than the intended use,
- failure to observe the indications and warnings contained in this Manual / Instruction sheet.

**Comelit Group S.p.A.** reserves the right to change the information provided in this Manual / Instruction Sheet at any time and without prior notice.

# Table of contents

<b>Warning</b> .....	<b>2</b>
<b>Description</b> .....	<b>4</b>
<b>UT2010</b> .....	<b>4</b>
<b>Technical characteristics</b> .....	<b>6</b>
<b>Art. UT2010</b> .....	<b>6</b>
<b>Installation</b> .....	<b>7</b>
Flush-mounted installation composition table.....	7
Surface-mounted installation composition table.....	7
<b>Flush-mounted installation</b> .....	<b>8</b>
<b>Removing nameplates (2A) / module (2B)</b> .....	<b>9</b>
<b>Installation with side-by-side boxes</b> .....	<b>10</b>
<b>Wall-mounted installation</b> .....	<b>11</b>
<b>Optional</b> .....	<b>11</b>
<b>Removing nameplates (2A) / module (2B)</b> .....	<b>12</b>
<b>Installation with side-by-side boxes</b> .....	<b>13</b>
<b>Connections</b> .....	<b>14</b>
<b>UT2010 connections</b> .....	<b>14</b>
<b>UT2010 connections with separate power supply</b> .....	<b>14</b>
<b>Variants</b> .....	<b>14</b>
<b>Module connection</b> .....	<b>15</b>
<b>Outdoor entrance panel module consumption table</b> .....	<b>15</b>
powered by Art. 1210/1210A.....	15
powered by additional power supply unit Art. 1595.....	15
Connection of button modules Art. UT9200.....	16
Connection of Touch-screen module Art. UT9270 .....	16
Connection of numeric keypad module Art. UT9279M .....	16
Variant with separate power supply.....	16
<b>Programming</b> .....	<b>17</b>
<b>Configure button type (single/dual)</b> .....	<b>17</b>
<b>Address button modules</b> .....	<b>17</b>
<b>Program call addresses</b> .....	<b>17</b>
<b>Smart programming of consecutive addresses</b> .....	<b>18</b>
<b>Programming of specific addresses</b> .....	<b>19</b>
<b>Special programming via DIP-switch</b> .....	<b>20</b>
<b>Special programming table</b> .....	<b>21</b>
<b>Twilight sensor</b> .....	<b>23</b>
<b>Button backlighting management</b> .....	<b>23</b>
<b>Checking twilight sensor operation</b> .....	<b>24</b>
<b>Adjusting the brightness of the button LEDs</b> .....	<b>25</b>
<b>Light-me function</b> .....	<b>26</b>
<b>Light-me function behaviour on the basis of the LED backlighting mode</b> .....	<b>26</b>
<b>Replacing the audio module with programming restore backup</b>	<b>27</b>
<b>Configuring via PC</b> .....	<b>28</b>
<b>Errors and indications</b> .....	<b>28</b>
<b>System performance and layouts</b> .....	<b>28</b>
<b>Addressing table</b> .....	<b>29</b>

# Description



## UT2010

Audio module for Ultra entrance panel, Simplebus2 system. For use in systems with power supply unit art. 1210 / 1210A.

*Easy to install and simple to configure, thanks to the smart programming of call buttons.*

*Twilight sensor for automatic nameplate backlighting switch-off during daylight hours.*

*Omnidirectional digital microphone and double loudspeaker for high-fidelity audio.*

*Audio-visual indications for disabled individuals assistance request can be activated via programming.*

*Facility for 2 call buttons. To be finished with cap, single button or dual button made using aluminium or professional grade plastic treated to prevent yellowing and dulling.*

*Adjustment and programming can take place without removing the module.*



*Dimensions: 1 Ultra module.*

**ULTRA: the new and most technologically advanced entrance panel that is perfectly easy to install.**

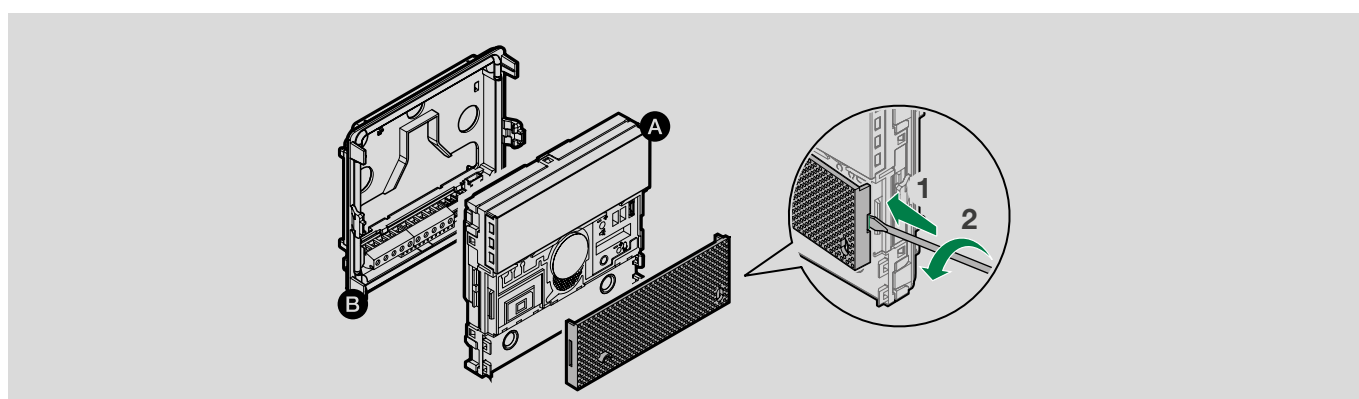
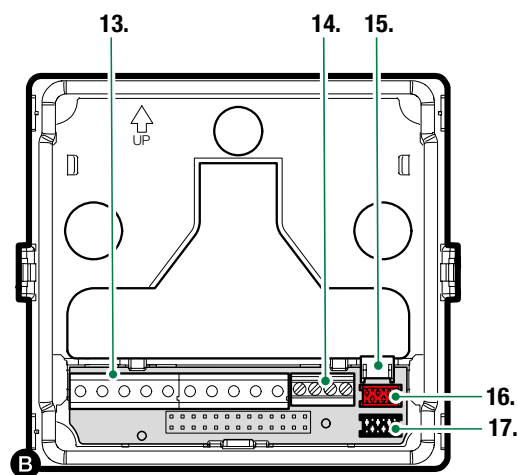
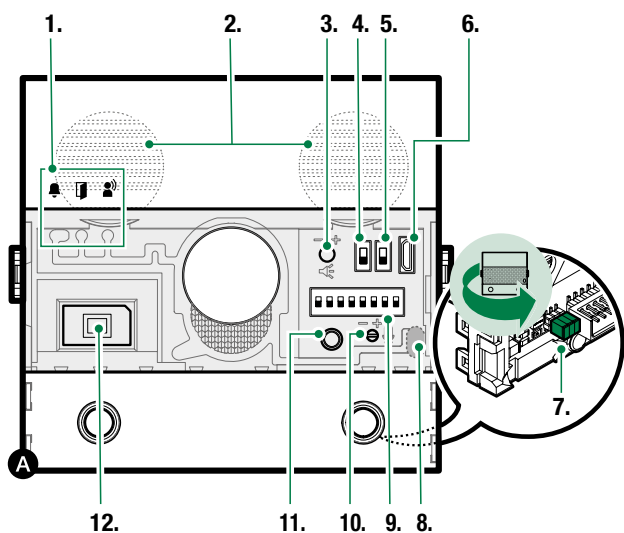
*Available in flush-mounted (10 mm protrusion from the wall) or surface-mounted (just 35 mm protrusion from the wall) variants.*



**1. Indicator LEDs**

-  call sent (green) / system busy (red)
-  lock-release enabled
-  audio enabled

**2. Loudspeakers**

**3. Speaker volume control #**

**4. S1 Button programming selector**

**5. S2 Special programming selector**

**6. Micro USB input for programming via computer**

**7. Jumper for power supply management (remove in case of separate power supply)**

**8. Twilight sensor**

**9. Addressing and programming Dip Switches**

**10. Microphone volume control #**

**11. Programming confirmation button #**

**12. Digital microphone**

# Use screwdriver supplied



**13. Terminal block for connection:**

- RTE** programmable RTE (local lock-release input) or DO input (door open indication)
- GND SE-** RTE and door lock input reference negative
- SE+** electric door lock connection
- NO NC COM** relay contacts
- V- V+** power supply
- LL** bus line connection

**14. Ethernet terminal block, only for use in case of additional modules with LAN**

**15. Connector for additional modules with LAN**

**16. 17. Connector for additional module connection**

# Technical characteristics

## Art. UT2010

<b>GENERAL DATA</b>	
Type	Modular
Product height (mm)	90
Product width (mm)	100
Product depth (mm)	35
Product weight (g)	275
Product colour	Black RAL9005, Transparent, Aluminium
Material	Polycarbonate, Aluminium alloy
Flush mounting	Yes, with specific accessory
Surface mounting	Yes, with specific accessory

<b>COMPATIBLE SYSTEMS</b>	
Simplebus 2 audio/video with power supply unit art. 1210/1210A	Yes
Simplebus 2 audio with power supply unit art. 1210/1210A	Yes

<b>AUDIO SPECIFICATIONS</b>	
Microphone	MEMS digital audio sensor, omnidirectional
Loudspeaker	28 mm (Ø), 8 Ohm, 1W (2)

<b>ELECTRICAL SPECIFICATIONS</b>	
Type of power supply	Power supply via video entry bus
Power supply voltage	33 VDC
Absorption in standby (W)	1.5
Maximum absorption (W)	3.5

<b>HARDWARE CHARACTERISTICS</b>	
Call type	Buttons
Type of buttons	Mechanical
Number of buttons (no.)	2
Backlighting colour	White, Off
Terminals	L L V+ V- COM NC NO SE+ SE-/GND RTE TX- TX+ RX- RX+
Number of inputs (no.)	1
Number of outputs (no.)	2
Communication port	Micro-USB
Twilight sensor	Yes

<b>SETTINGS</b>	
Loudspeaker volume	Yes
Mic volume	Yes
Backlighting brightness	Yes

<b>ENVIRONMENTAL AND CONFORMITY SPECIFICATIONS</b>	
Operating temperature (°C)	-25 to 55
Operating humidity (max RH - %)	25 to 95
Environmental class	III
Conformity and Certifications	RoHS II - 2011/65/EU (EN 50581:2012), EMC 2014/30/EU (EN61000-6-1:2007, EN 61000-6-3:2007+A1:2011)

  

<b>MAIN FUNCTIONS</b>	
Lock-release	Yes
Number of auxiliary relays (no.)	1
Input for local key button	Yes
Input for door open signal	Yes
System status visual indications	Yes
System status audio indications	Yes
System status voice synthesis	Yes







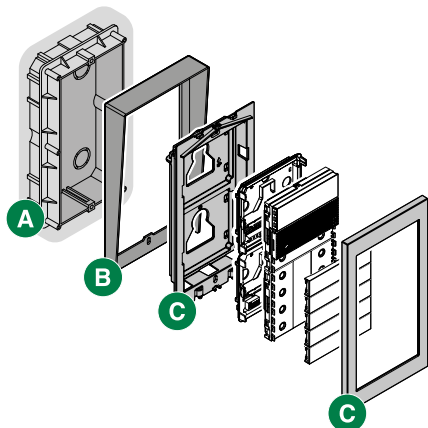



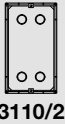

# Installation

The entrance panel is available in flush-mounted or surface-mounted variants:

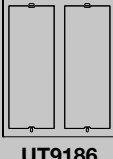
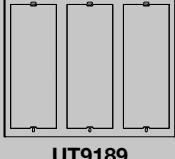
## Flush-mounted installation composition table



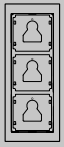





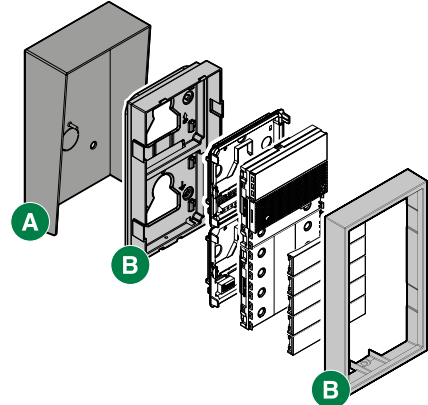

A = Flush-mounted box  
 B = Rain shield #  
 C = Flush-mounted module holder with finishing frame

Flush-mounted box									
	3110/1	3110/2	3110/3			3110/4			
	Rain shield								
		UT9181	UT9182	UT9183	UT9186	UT9189		UT9184	UT9188
Module holder/ finishing frame									
		UT9161	UT9162	UT9163			UT9164		

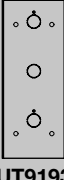
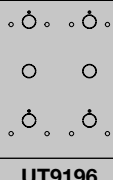
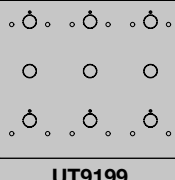
## Surface-mounted installation composition table

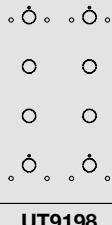

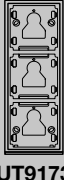
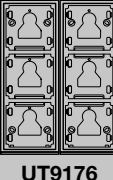
A = Rain shield #  
 B = Surface-mounted housing with frame

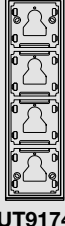
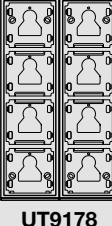
Rain shield									
	UT9191	UT9192	UT9193	UT9196	UT9199		UT9194	UT9198	
	Housing/frame								
		UT9171	UT9172	UT9173	UT9176	UT9179		UT9174	UT9178

# Optional

# Flush-mounted installation

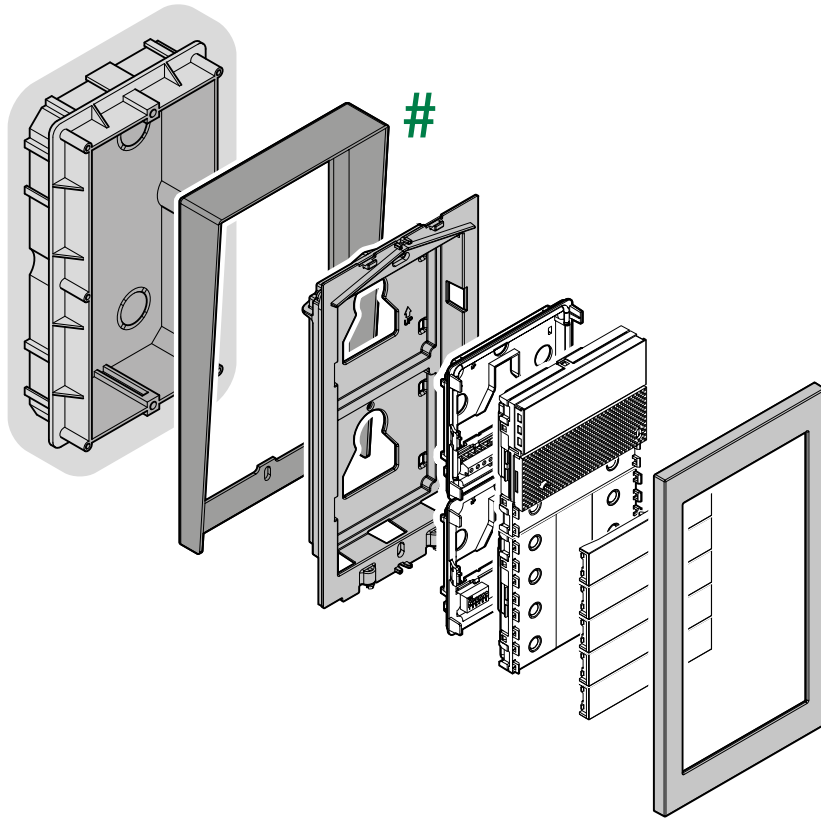

# Optional

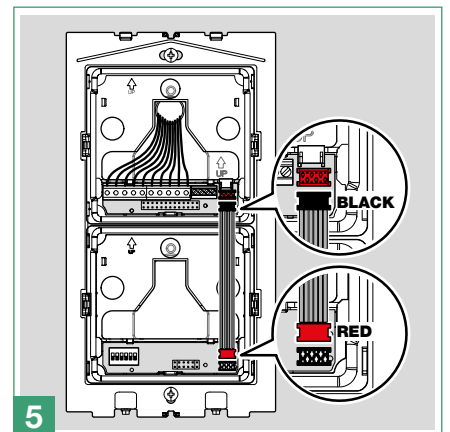
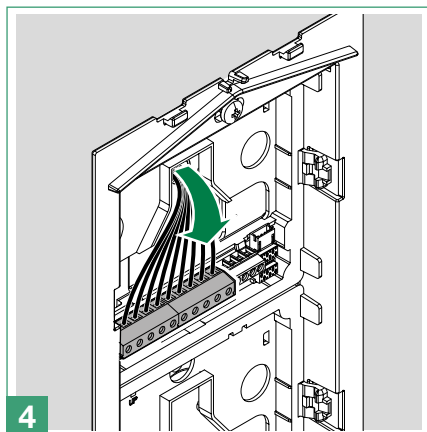
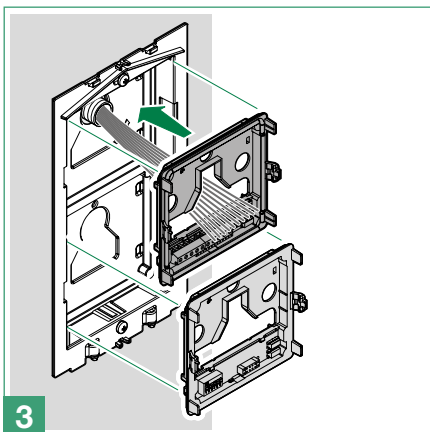
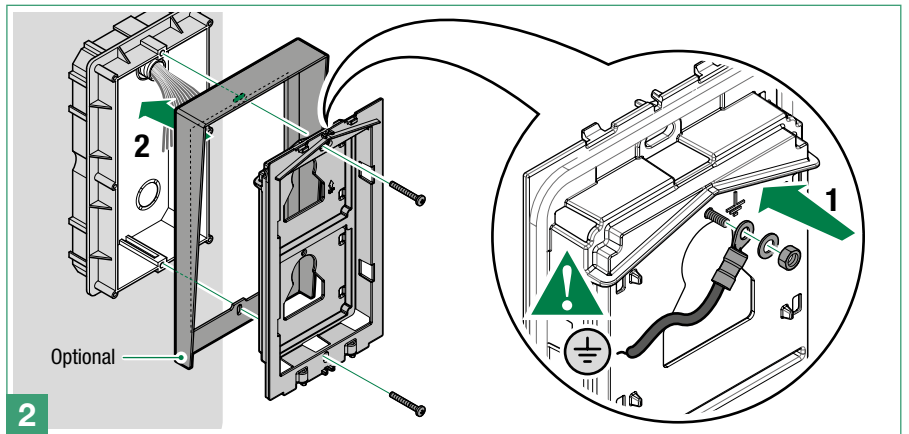
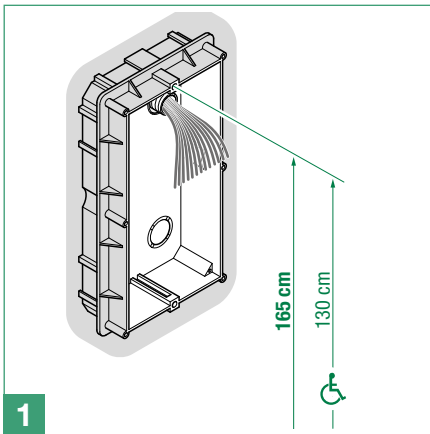



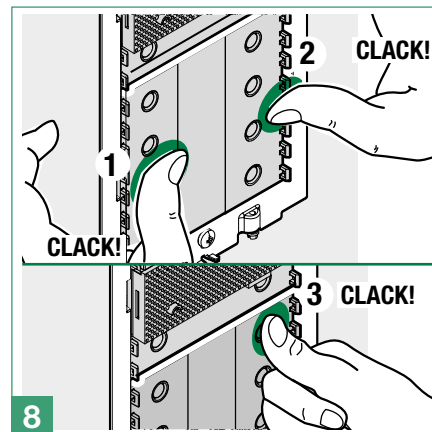
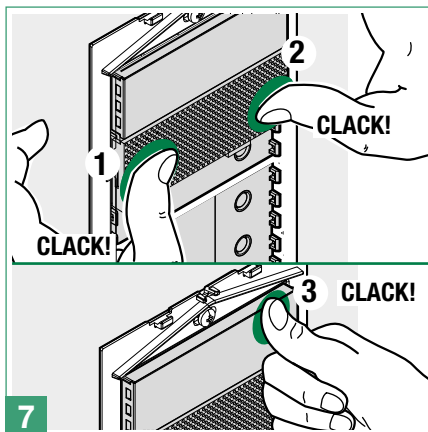
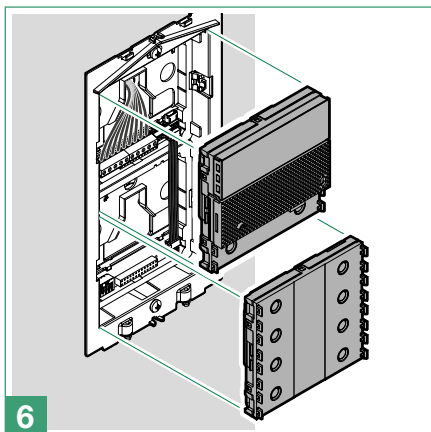

The button has a nameplate which can be written on (A); alternatively, an adhesive label can be applied (B).

**The total thickness of the nameplate + adhesive label must not exceed 0.2 mm.**

You can visit the website [pro.comelitgroup.com](http://pro.comelitgroup.com) to download the PDF to print the entrance panel name cards, using the adhesive pre-cut sheets (C) available in our catalogue (Art. UT9110)

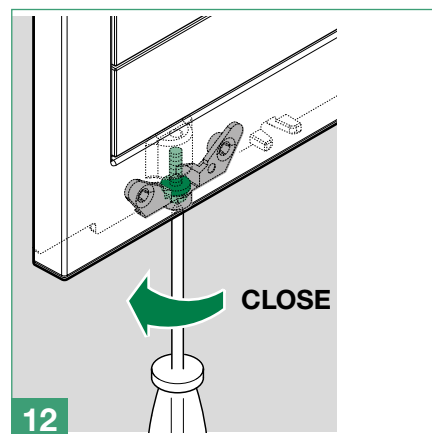
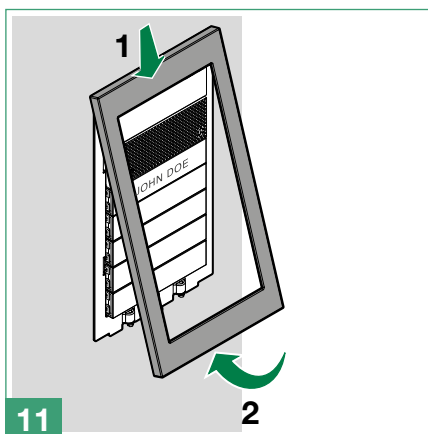
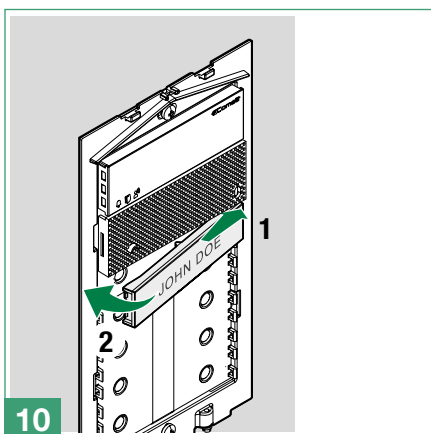

### Removing nameplates (2A) / module (2B)

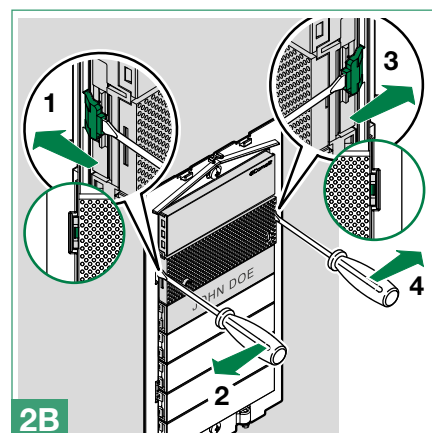
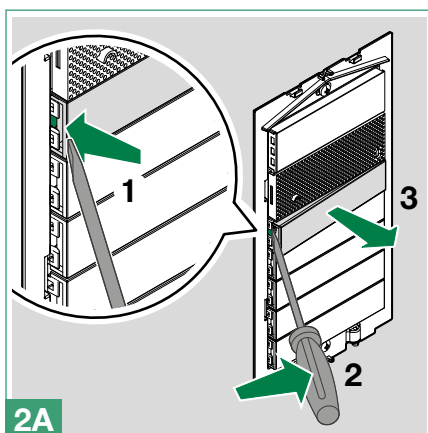
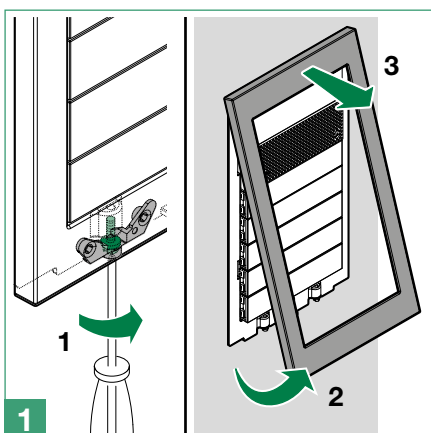

## Installation with side-by-side boxes

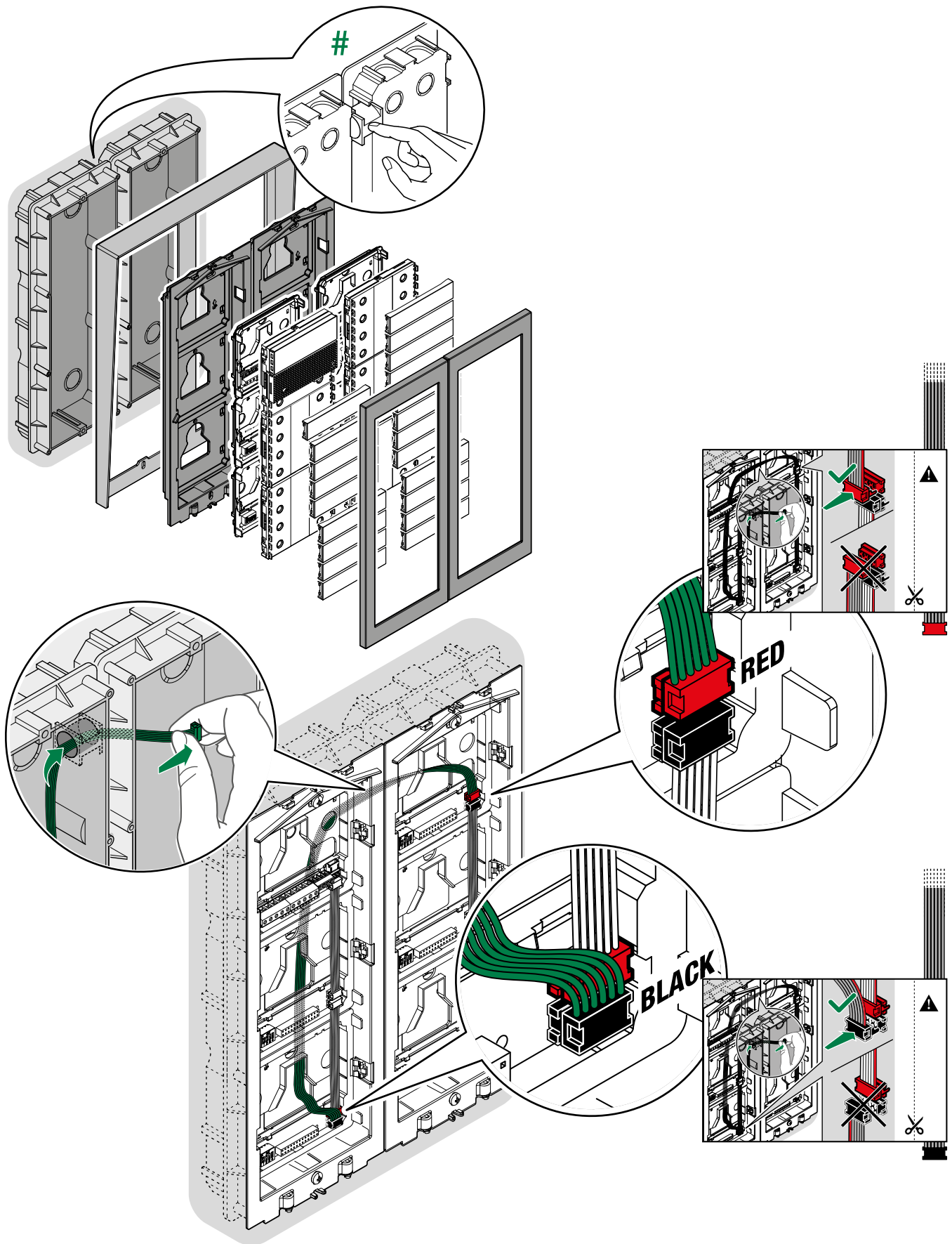

# Before installing the boxes in the wall, fit the spacers.

# Wall-mounted installation

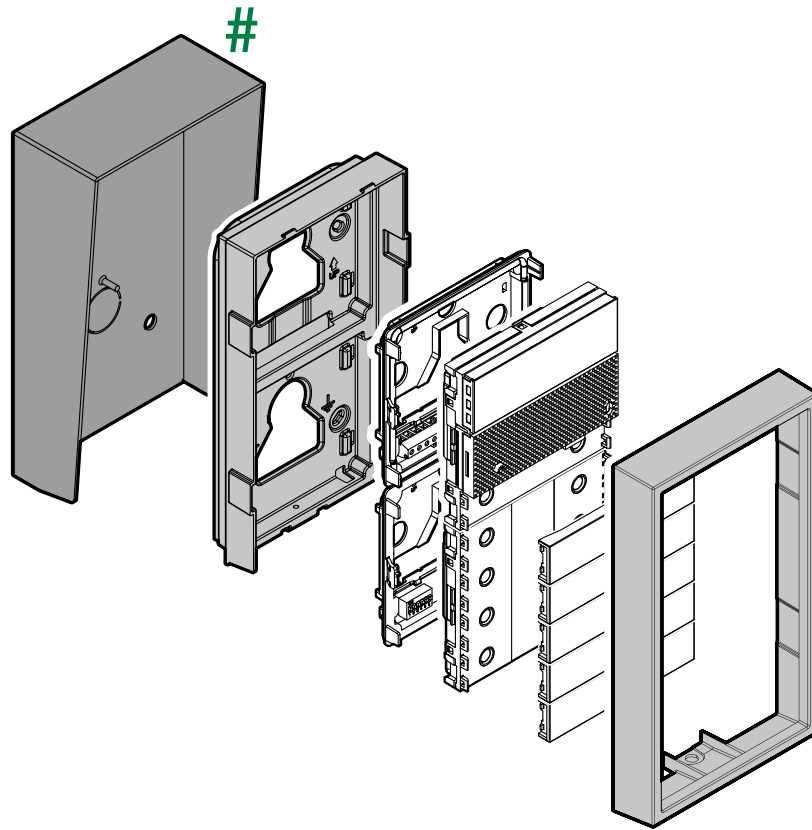

# Optional

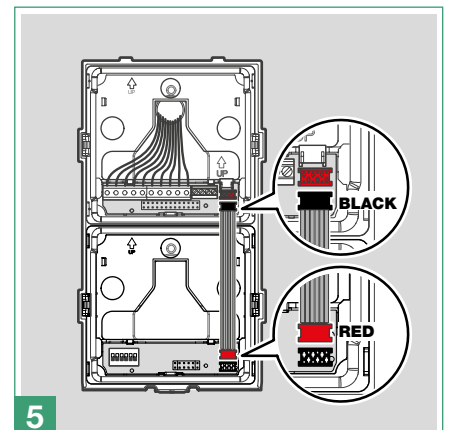
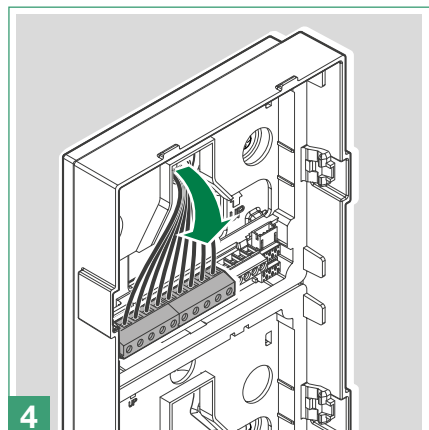
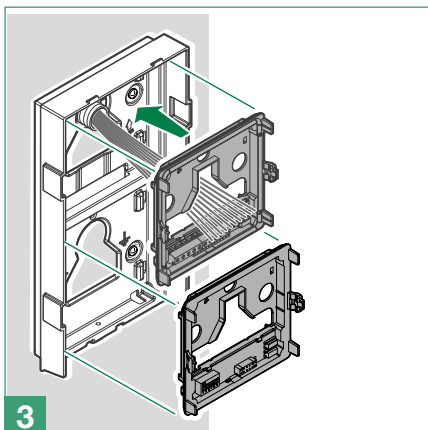
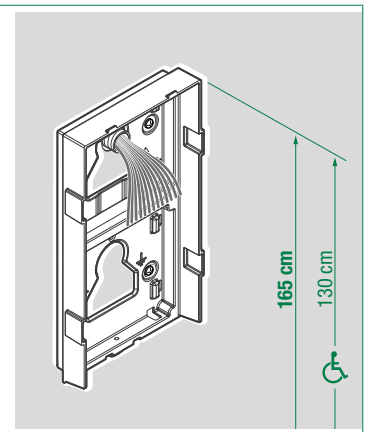
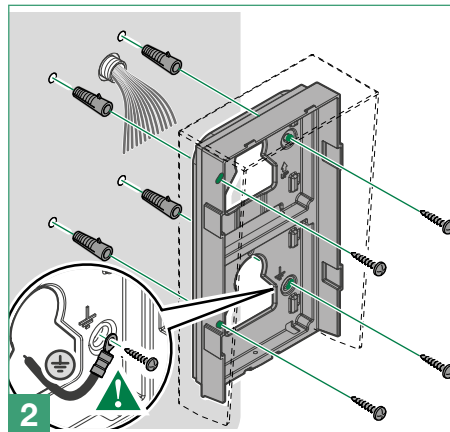
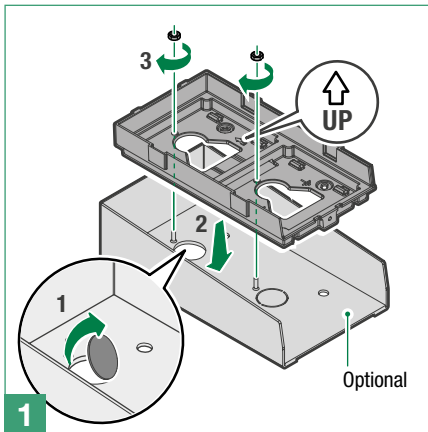

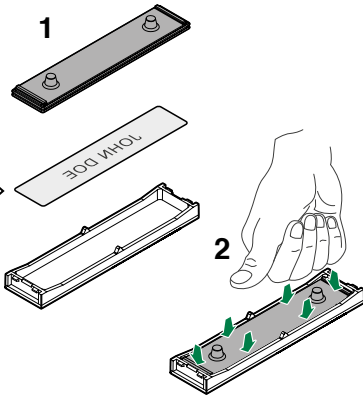
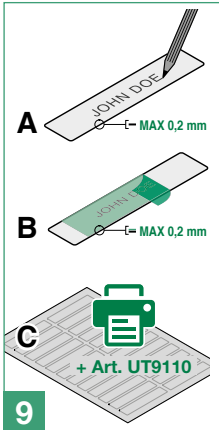
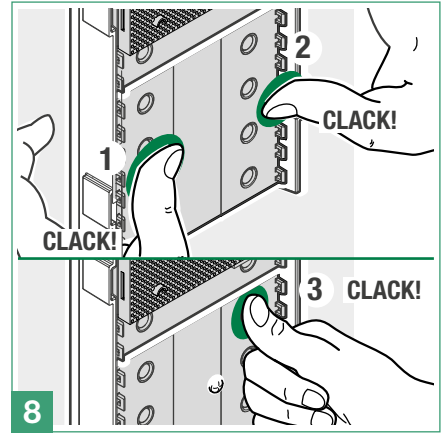
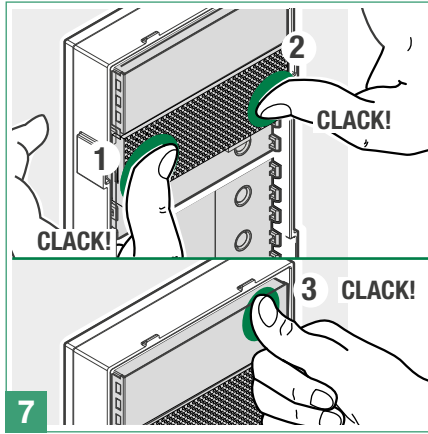
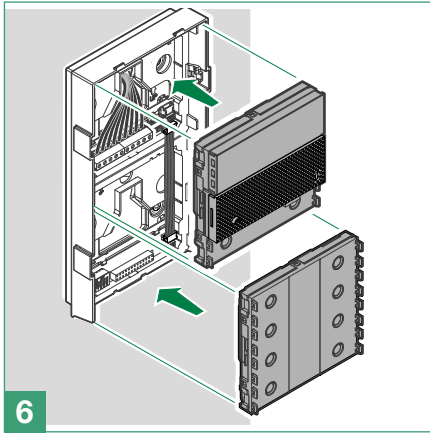

The button has a nameplate which can be written on (A); alternatively, an adhesive label can be applied (B).

**The total thickness of the nameplate + adhesive label must not exceed 0.2 mm.**

You can visit the website [pro.comelitgroup.com](http://pro.comelitgroup.com) to download the PDF to print the entrance panel name cards, using the adhesive pre-cut sheets (C) available in our catalogue (Art. UT9110)

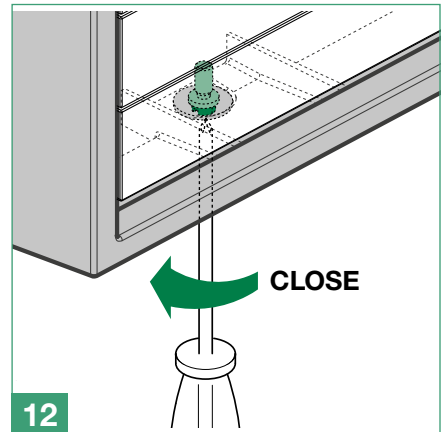
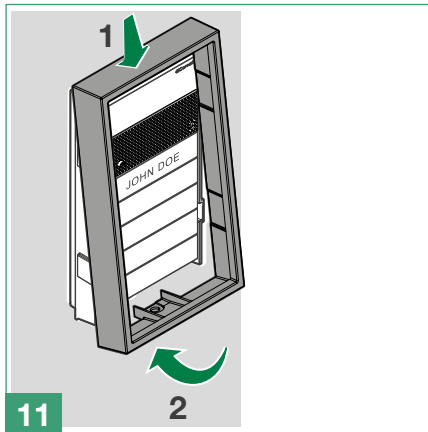
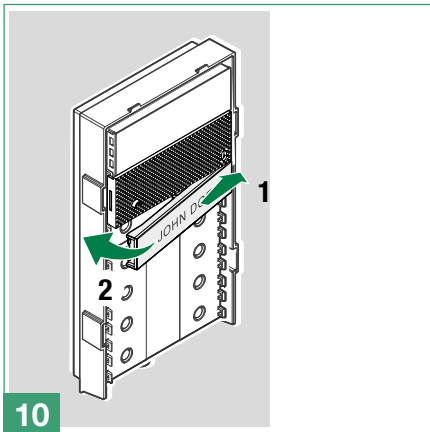

### Removing nameplates (2A) / module (2B)

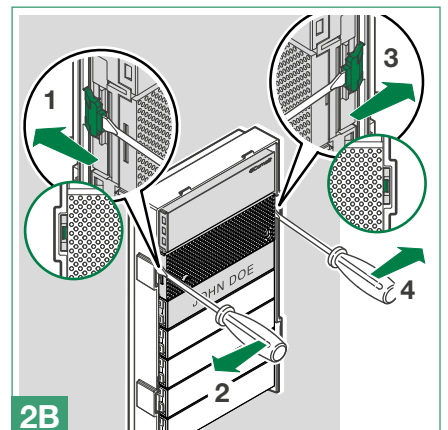
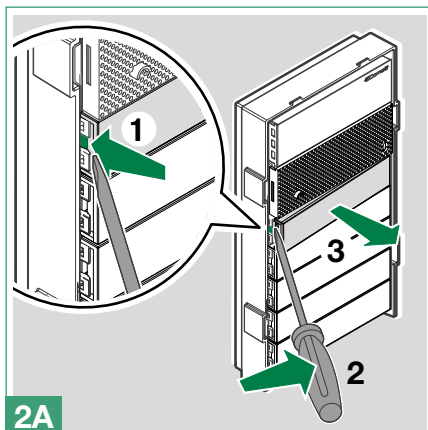
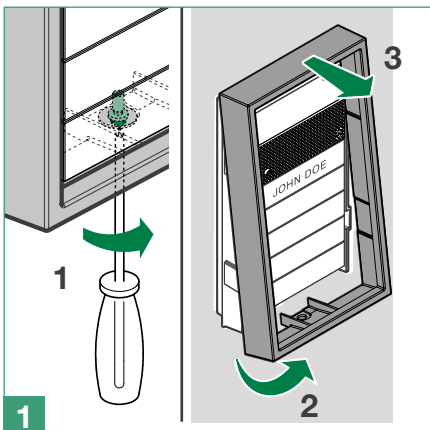

# Installation with side-by-side boxes

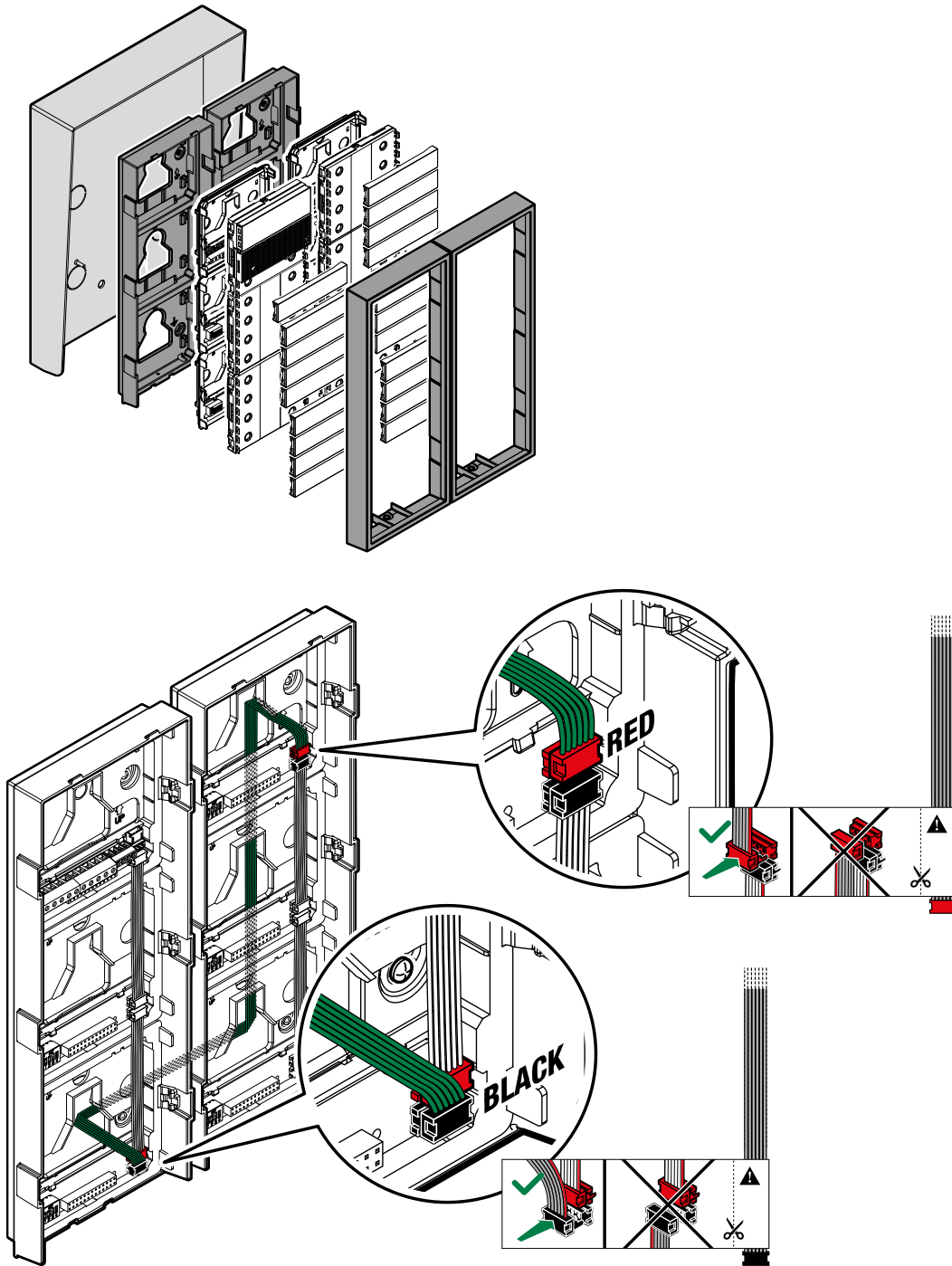

# Connections

## UT2010 connections

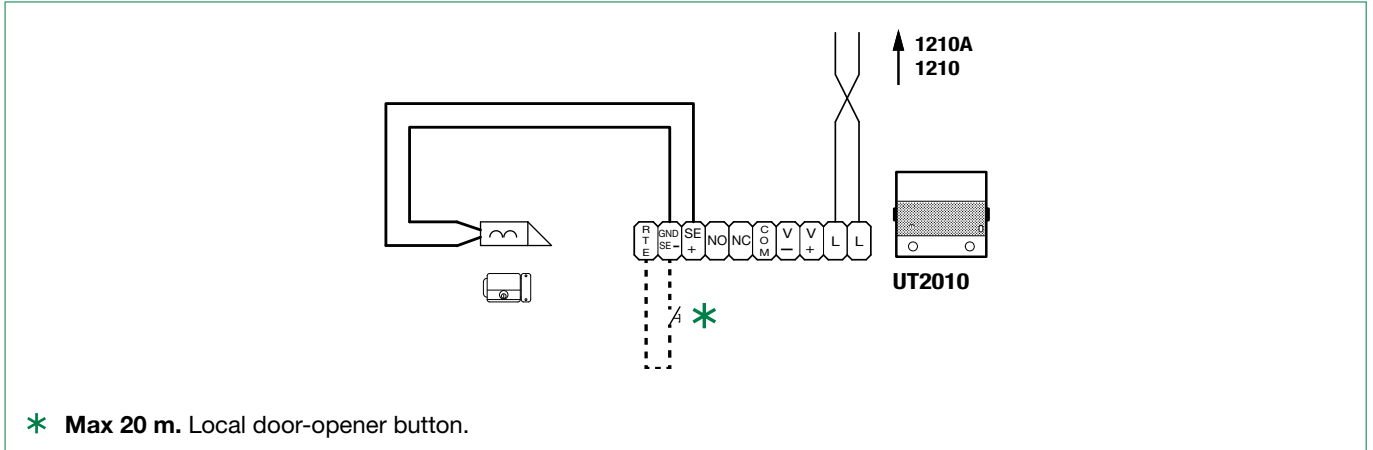

## UT2010 connections with separate power supply

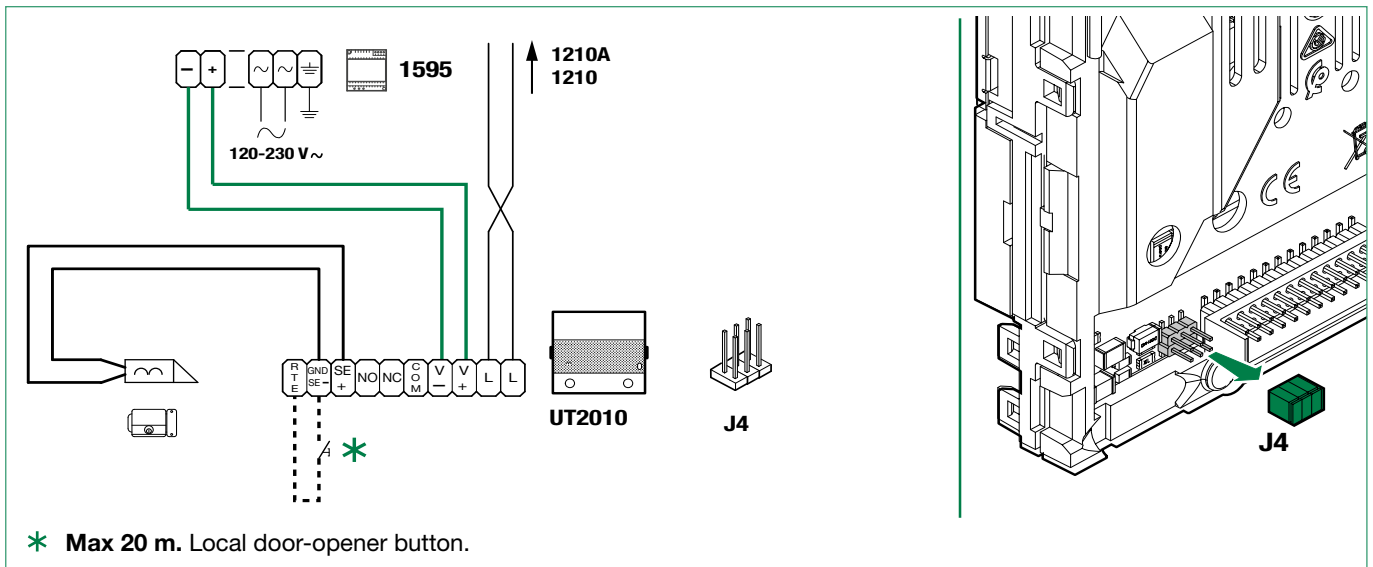

## Variants

### Variant for using the outdoor entrance panel relay

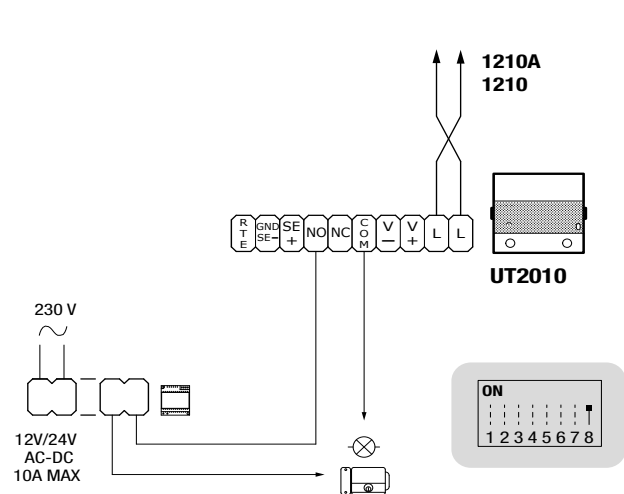

### Variant for using a safety door lock

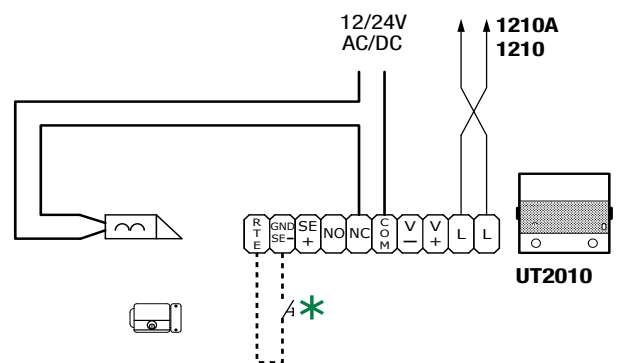

# Module connection

On systems with Art. UT2010 and power supply unit Art. 1210/1210A, the maximum current available for the outdoor entrance panel modules is 100 mA.



Calculate the total power consumption of the modules in your system configuration using the Consumption table.

If the total power consumption exceeds 100 mA, connect a supplementary power supply unit (Art. 1595) to the V+ and V- contacts of the outdoor entrance panel, as shown in the figure below (see [“UT2010 connections with separate power supply”](#)). In any case, the total absorption must be lower than 500 mA.

## A powered by Art. 1210/1210A

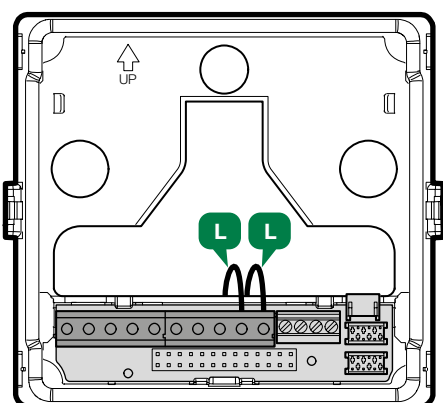

## B powered by additional power supply unit Art. 1595

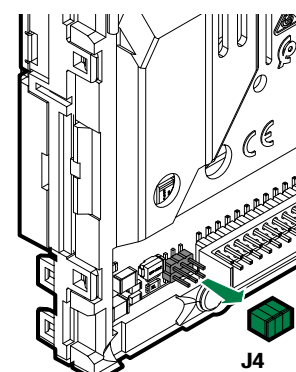
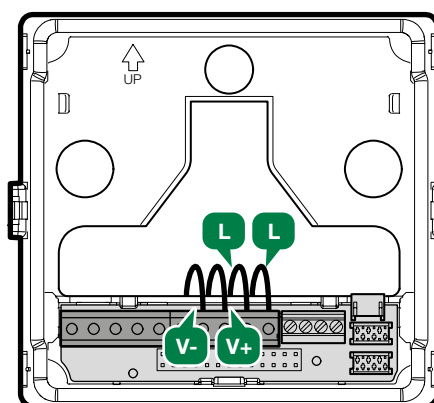

## Outdoor entrance panel module consumption table

Code		Consumption (mA)	
UT9200	Call button modules	12.5	
UT9240	Information module	12.5	
UT9240M	Metal information module	12.5	
UT9279M	Numeric keypad module	40	With SE output active
		75	With 1 bistable relay active
		100	With 2 bistable relays active at the same time
UT9310M	Magnetic induction module	245	Always needs to be powered by additional power supply unit Art. 1595
UT9270	Touch-screen module	100	In systems with an outdoor entrance panel consisting of 1 audio or audio/video module, Touch module art. UT9270 and up to 80 users, it is not necessary to provide any additional power supply.  For all other combinations, provide an additional power supply unit art. 1595

### Connection of button modules Art. UT9200

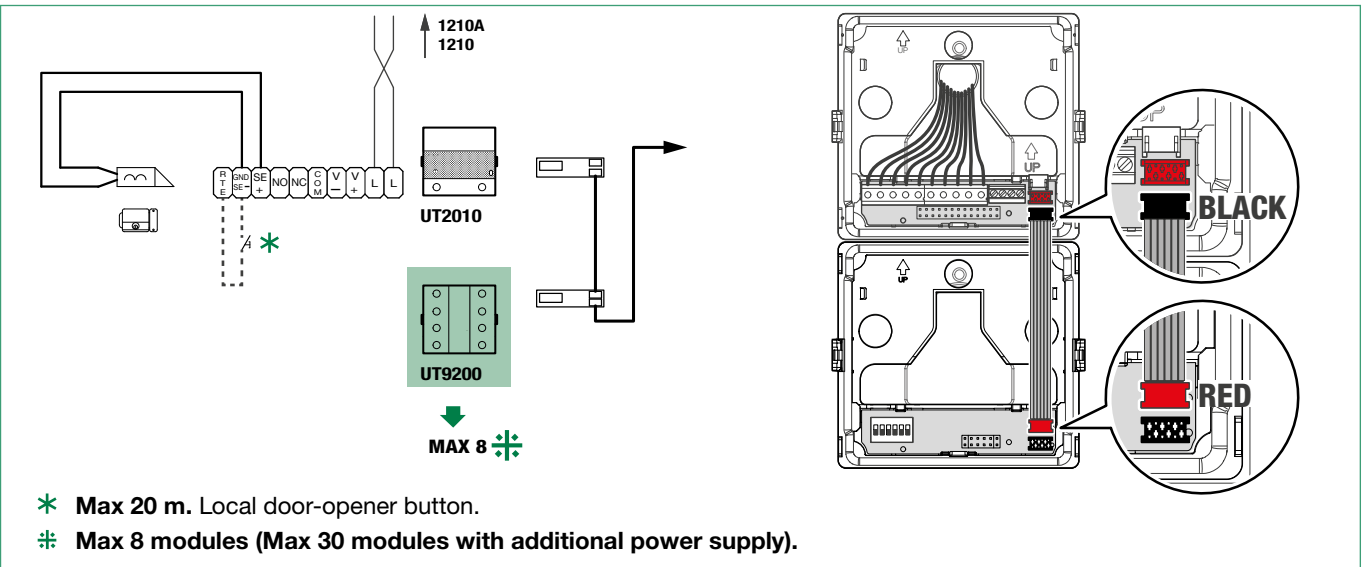

### Connection of Touch-screen module Art. UT9270

### Variant with separate power supply

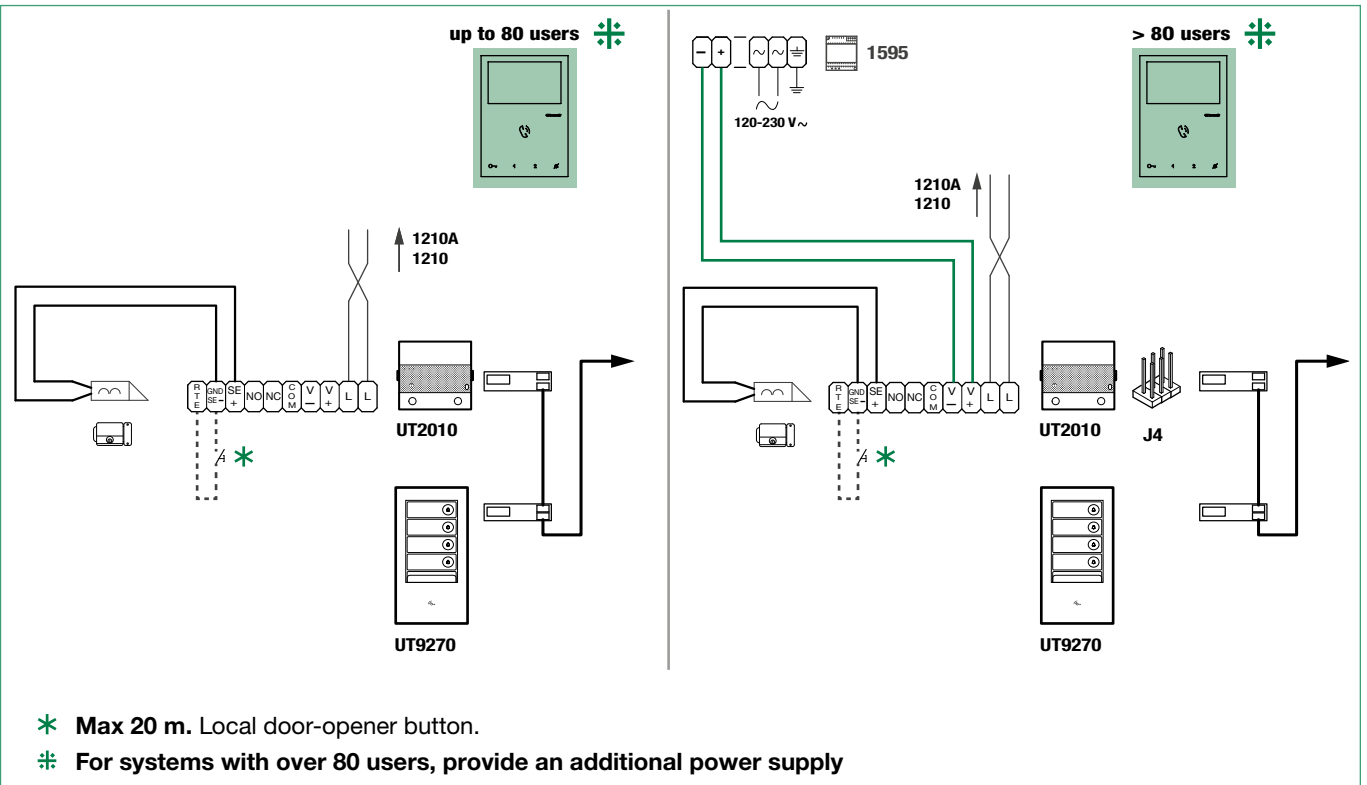

### Connection of numeric keypad module Art. UT9279M

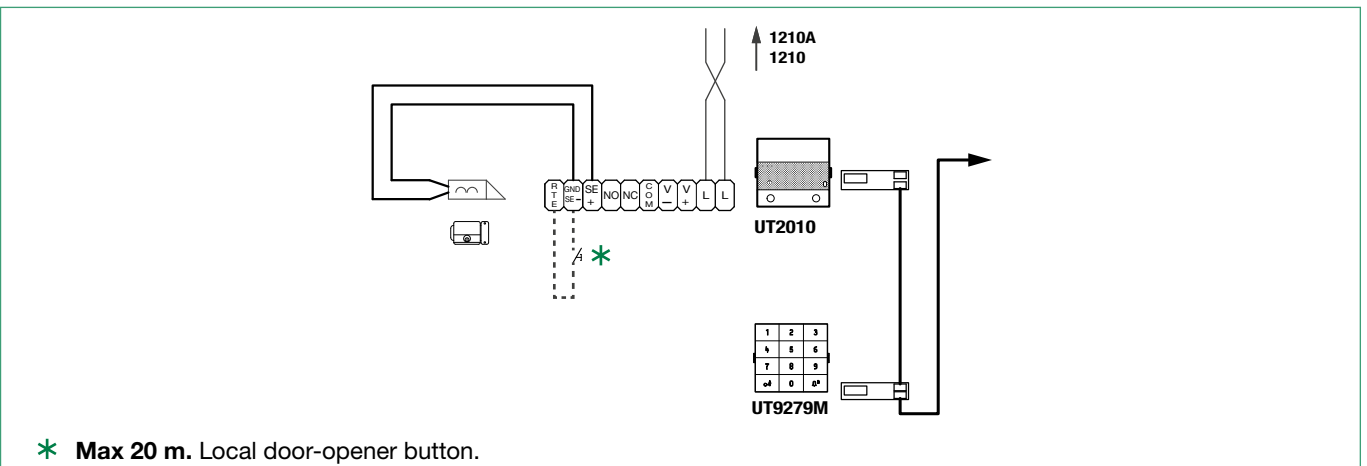



# Programming

For correct programming, follow the instructions below in order

- I. Configure button type
- II. Address button modules
- III. Program call addresses

## I Configure button type (single/dual)

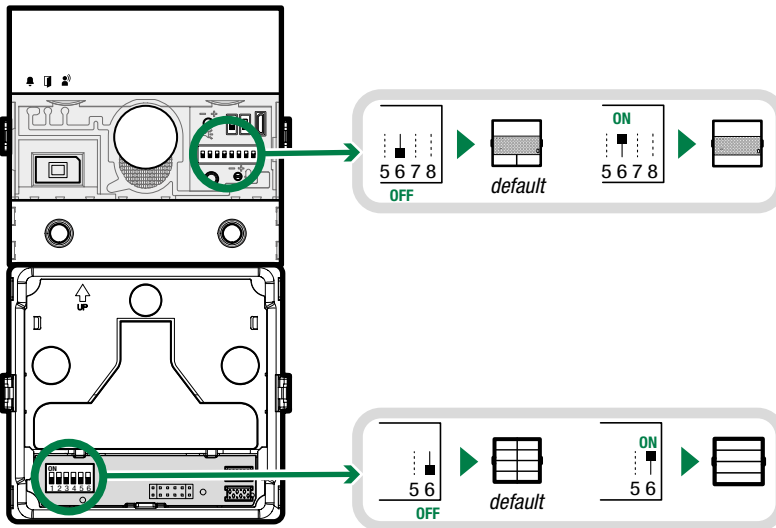

**DIP 6:** configuring button type:  
Single button (**DIP6 ON**).  
Dual button (**DIP6 OFF, default**).

**DIP 6:** configuring button type:  
Single button (**DIP6 ON**).  
Dual button (**DIP6 OFF, default**).

## II Address button modules

**DIP 1-5:** addressing call button module (see TAB. A)

Addressing call button modules means that, in the event they are replaced, it is not necessary to reprogram the button addresses. All you need to do is assign the same address as before to the new module.

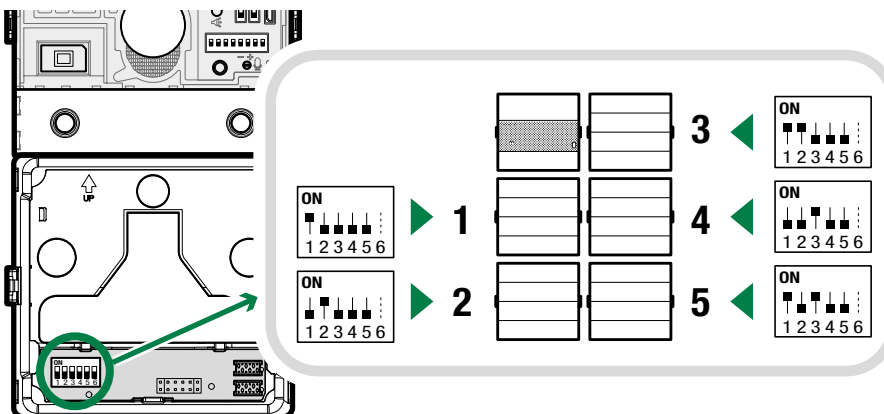

**TAB. A**

code	DIP ON				
1	1	12	3,4	23	1,2,3,5
2	2	13	1,3,4	24	4,5
3	1,2	14	2,3,4	25	1,4,5
4	3	15	1,2,3,4	26	2,4,5
5	1,3	16	5	27	1,2,4,5
6	2,3	17	1,5	28	3,4,5
7	1,2,3	18	2,5	29	1,3,4,5
8	4	19	1,2,5	30	2,3,4,5
9	1,4	20	3,5	31	1,2,3,4,5
10	2,4	21	1,3,5		
11	1,2,4	22	2,3,5		

## III Program call addresses

There are 2 programming methods:

- **Smart programming of consecutive addresses:** allows quick programming of buttons with consecutive addresses (e.g.: 1, 2, 3, 4)
- **Programming of specific addresses:** allows programming of specific addresses (e.g.: 25, 37, 70, 58)

# Smart programming of consecutive addresses



Make sure the button configuration (single/dual) is correct before proceeding with programming (see [“Configure button type \(single/dual\)”](#))

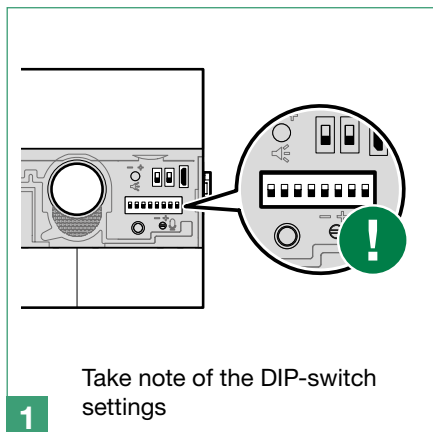

1 Take note of the DIP-switch settings

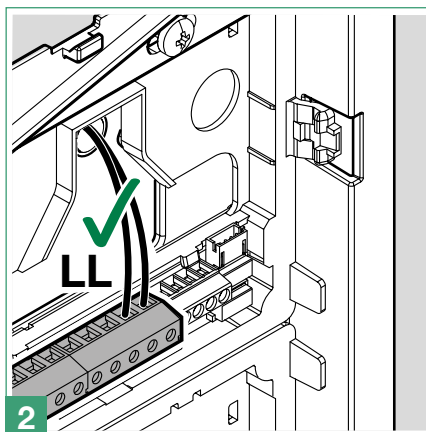

2

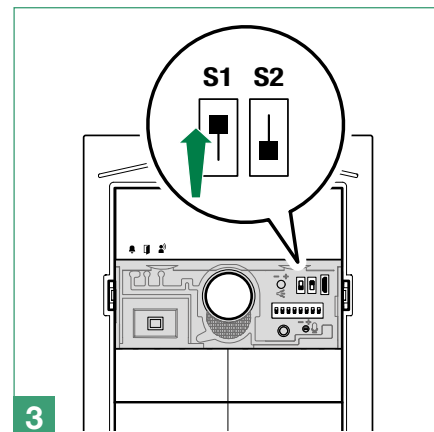

3

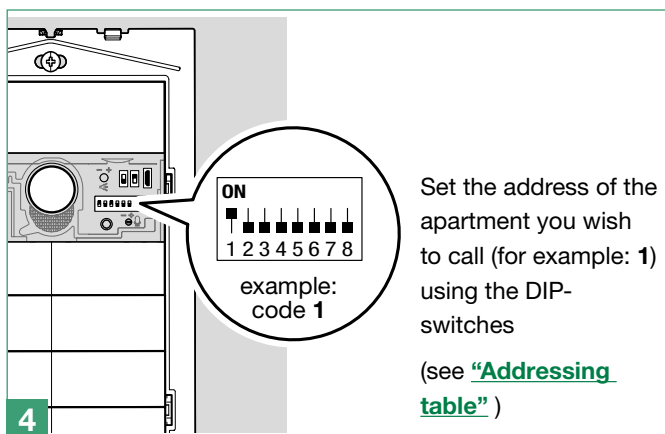

4 Set the address of the apartment you wish to call (for example: 1) using the DIP-switches (see [“Addressing table”](#))

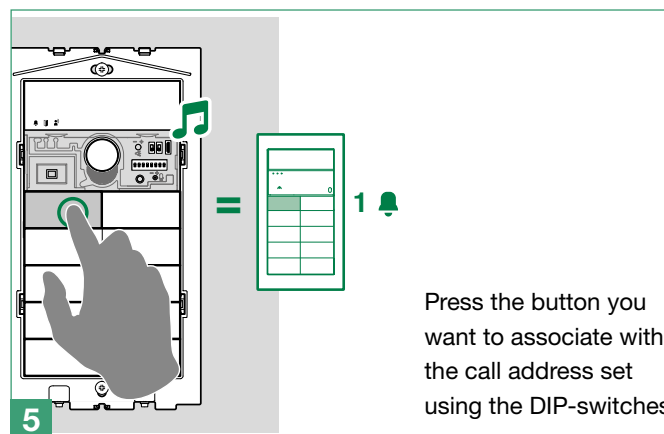

5 Press the button you want to associate with the call address set using the DIP-switches

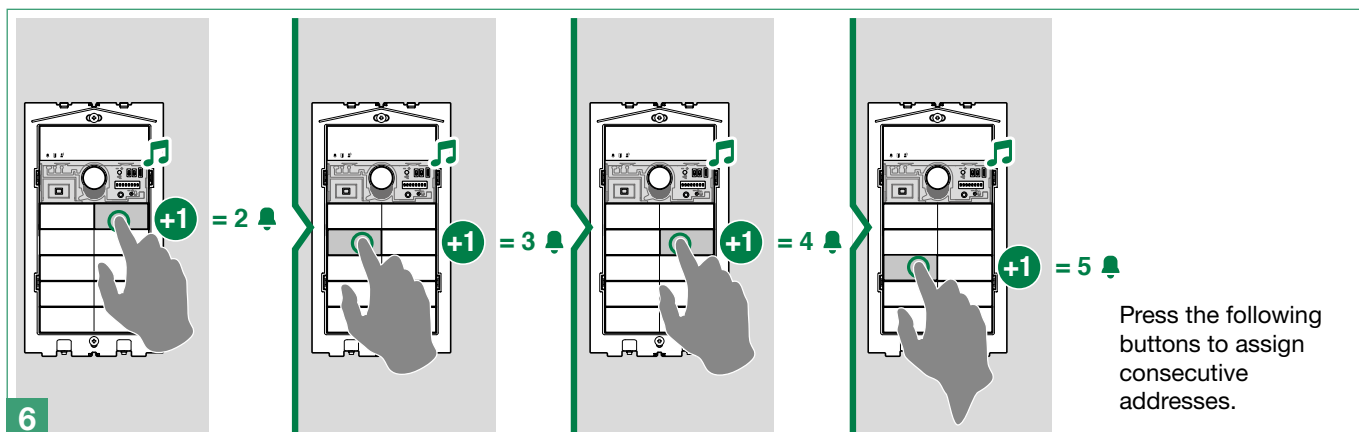

6 Press the following buttons to assign consecutive addresses.

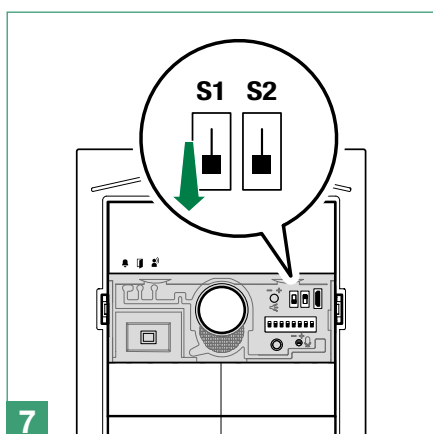

7

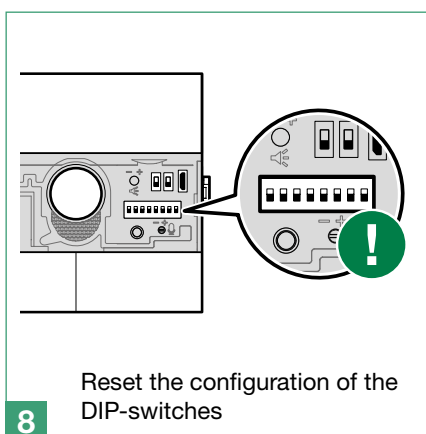

8 Reset the configuration of the DIP-switches



When programming is complete, make sure the button configuration is correct (single/dual), see [“Configure button type \(single/dual\)”](#)

# Programming of specific addresses



Make sure the button configuration (single/dual) is correct before proceeding with programming (see [“Configure button type \(single/dual\)”](#))

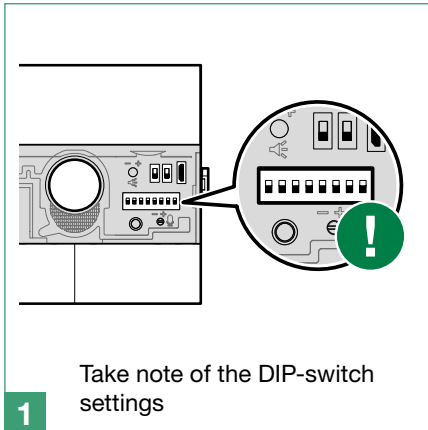

1 Take note of the DIP-switch settings

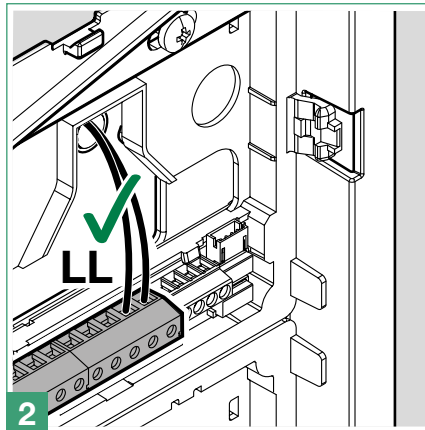

2

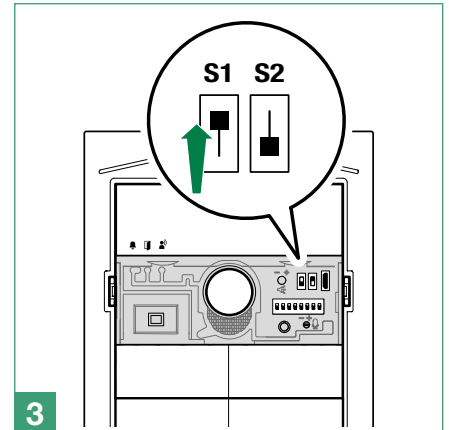

3

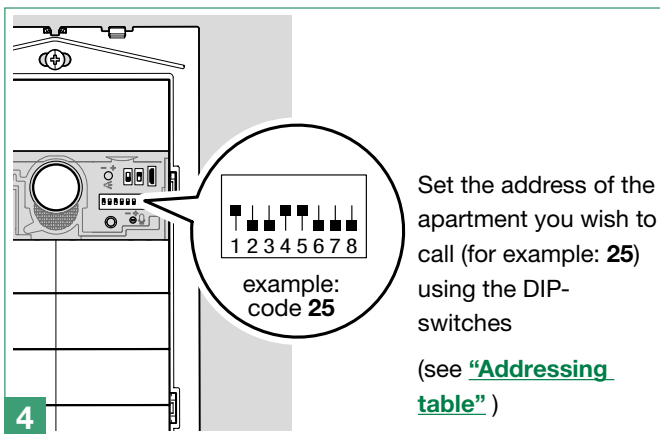

4

Set the address of the apartment you wish to call (for example: 25) using the DIP-switches (see [“Addressing table”](#))

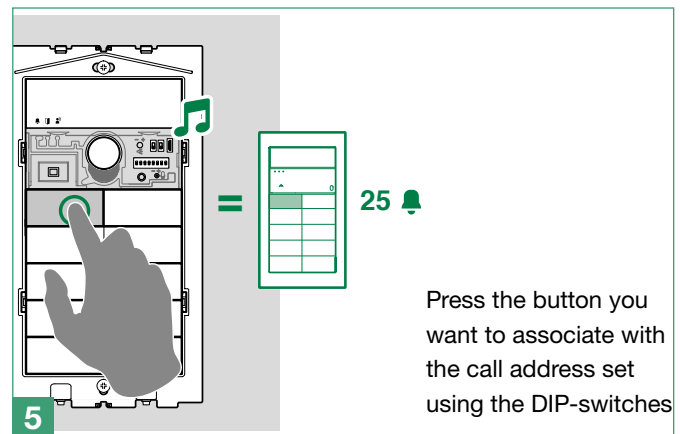

5

Press the button you want to associate with the call address set using the DIP-switches

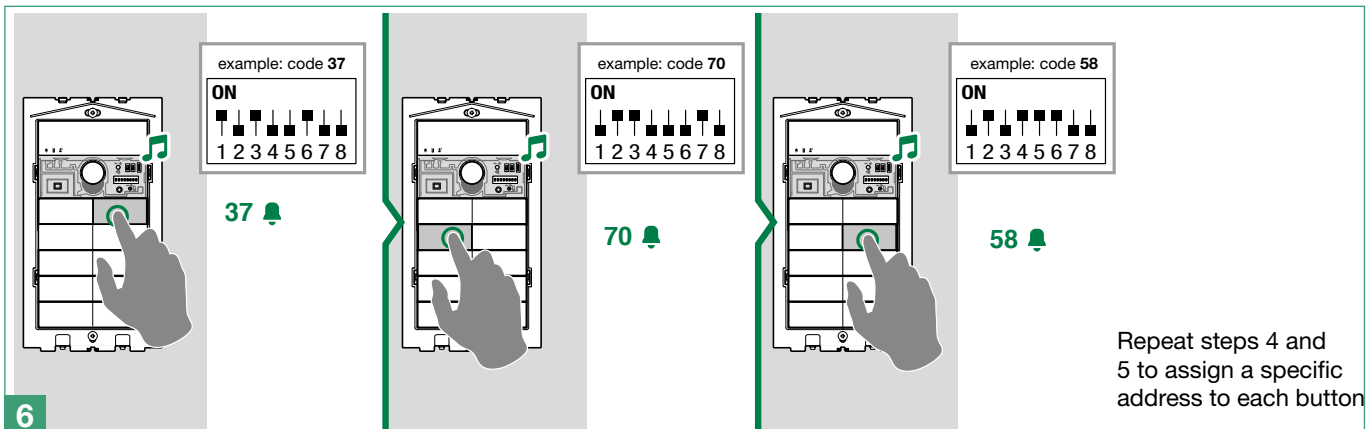

6

Repeat steps 4 and 5 to assign a specific address to each button

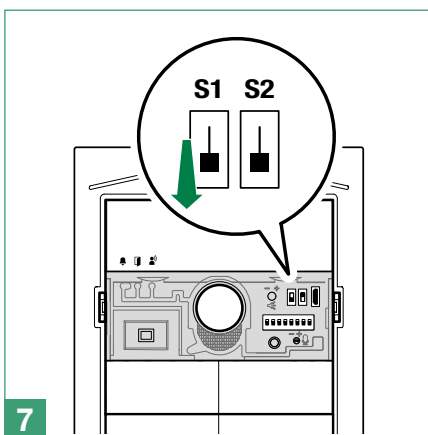

7

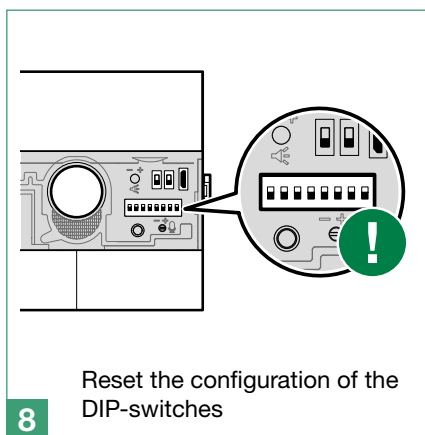

8

Reset the configuration of the DIP-switches



When programming is complete, make sure the button configuration is correct (single/dual), see [“Configure button type \(single/dual\)”](#)

# Special programming via DIP-switch

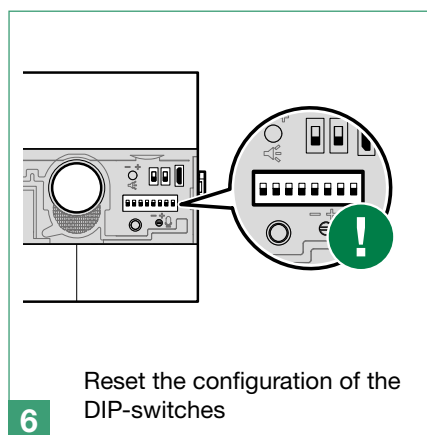
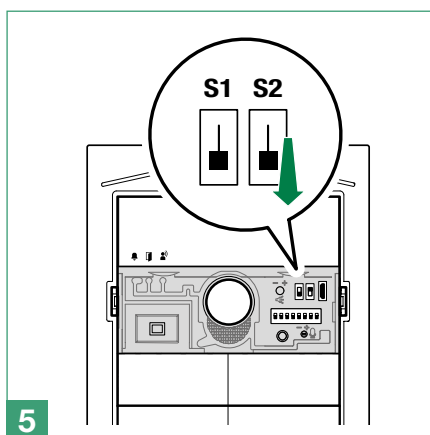
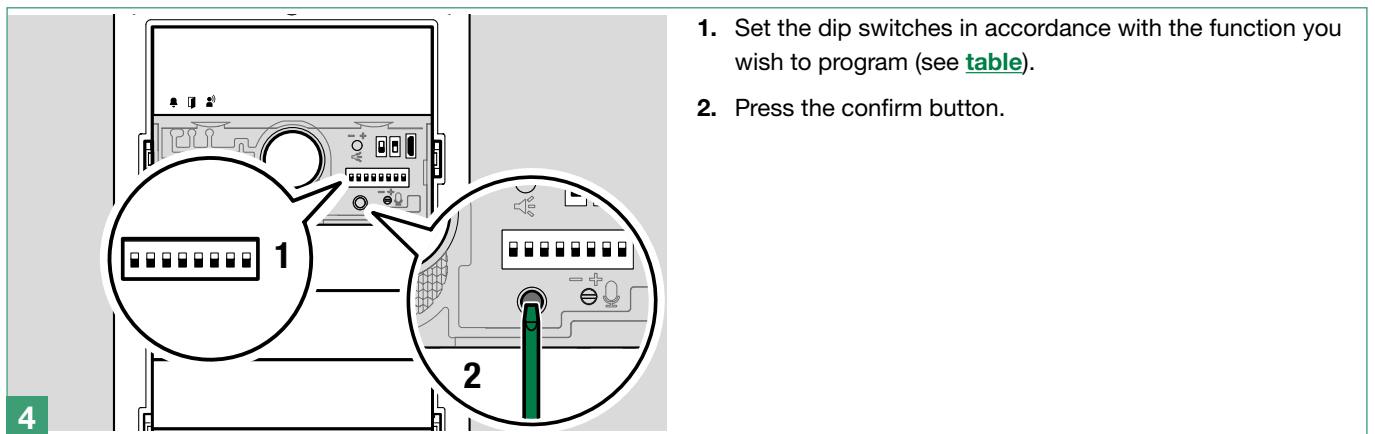
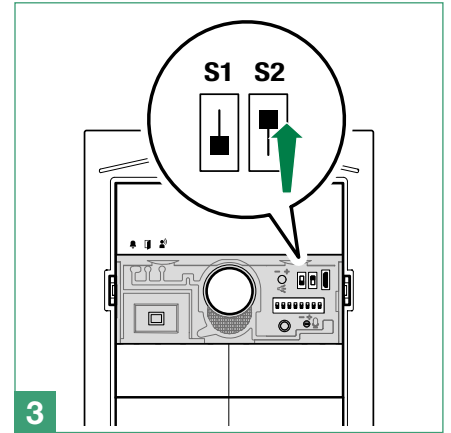
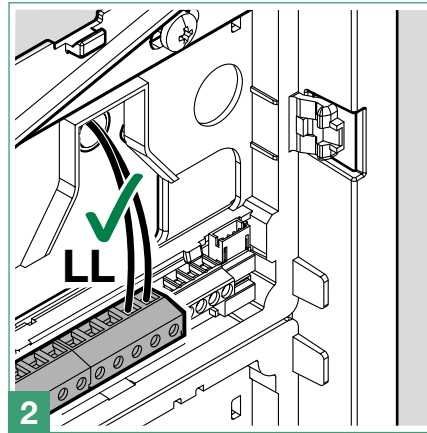
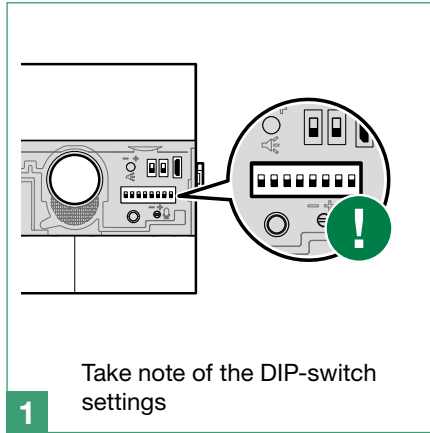

**!** When programming is complete, make sure the button configuration is correct (single/dual), see [“Configure button type \(single/dual\)”](#)

## Special programming table

CODE	DIP SWITCHES ON	FUNCTIONS
		<b>Audio-visual messages</b>
195	1,2,7,8	Hebrew
196	3,7,8	Polish
197	1,3,7,8	Catalan
198	2,3,7,8	Galician
199	1,2,3,7,8	Basque
206	2,3,4,7,8	Danish
207	1,2,3,4,7,8	Norwegian
211	1,2,5,7,8	Swedish
215	1,2,3,5,7,8	Italian
216	4,5,7,8	French
217	1,4,5,7,8	Spanish
218	2,4,5,7,8	Dutch
219	1,2,4,5,7,8	Greek
220	3,4,5,7,8	English
221	1,3,4,5,7,8	German
222	2,3,4,5,7,8	Portuguese
202	2,4,7,8	Enables voice message (door opened warning) when the RTE contact is closed
203	1,2,4,7,8	Disables voice message (door opened warning) when the RTE contact is closed <b>(default setting)</b>
210	2,5,7,8	Enables visual messages and disables voice messages <b>(default)</b>
214	2,3,5,7,8	OFF: disables voice and visual messages
		<b>Actuator command management</b> <b>N.B. Art. 1256 in generic actuator mode must not be present in the system.</b>
229	1,3,6,7,8	C.NC.NO relay activation on actuator command: 2 sec <b>(default)</b>
230	2,3,6,7,8	C.NC.NO relay activation on actuator command: 4 sec
231	1,2,3,6,7,8	C.NC.NO relay activation on actuator command: 8 sec
		<b>Door lock</b>
245	1,3,5,6,7,8	Door lock time: 2 sec + disabling tone <b>(default)</b>
246	2,3,5,6,7,8	Door lock time: 4 sec
247	1,2,3,5,6,7,8	Door lock time: 8 sec
248	4,5,6,7,8	Door lock confirmation tone: enabled
252	3,4,5,6,7,8	Lock-release always enabled <b>(default)</b>
253	1,3,4,5,6,7,8	Lock-release only enabled for user called
		<b>System functions</b>
232	4,6,7,8	Awaiting response time: 60 sec <b>(default)</b>
233	1,4,6,7,8	Awaiting response time: 120 sec
234	2,4,6,7,8	Awaiting response time: 30 sec
235	1,2,4,6,7,8	Talk time: 90 sec <b>(default)</b>
236	3,4,6,7,8	Talk time: 180 sec
145	1,5,8	RTE input set as local lock-release input <b>(default)</b>
146	2,5,8	RTE input set as door open indication
154	2,4,5,8	System busy signalling time: 10 sec <b>(default)</b>
155	1,2,4,5,8	System busy signalling time: 300 sec
239	1,2,3,4,6,7,8	Confirmation tone on user call = enabled <b>(default)</b>
240	5,6,7,8	Confirmation tone on user call = disabled
243	1,2,5,6,7,8	Reset wait time (after hang-up or after lock-release): 10 sec <b>(default)</b>
244	3,5,6,7,8	Reset wait time (after hang-up or after lock-release): 1 sec
208	5,7,8	Enables "Reset wait time" on lock-release command <b>(default)</b>

209	1,5,7,8	Disables "awaiting reset time" on lock-release command (awaiting response time or talk time will be activated)
249	1,4,5,6,7,8	Call transmission: single <b>(default)</b>
250	2,4,5,6,7,8	Call transmission: triple
<b>Button tones</b>		
142	2,3,4,8	Button press tone ON <b>(default)</b>
143	1,2,3,4,8	Button press tone OFF
<b>Button backlighting management</b>		
158	2,3,4,5,8	OFF mode: Button LEDs always off
159	1,2,3,4,5,8	ON mode: Button LEDs always on
160	6,8	AUTO mode: Button LEDs on at night and off during the day, thanks to the twilight sensor <b>(default)</b>
161	1,6,8	Enables brightness control for the button LEDs. ▶ Press a button repeatedly for each module to change the individual brightness of the buttons (see: <a href="#">"Adjusting the brightness of the button LEDs"</a> )
162	2,6,8	Light-me OFF <b>(default)</b>
163	1,2,6,8	Light-me ON: the button LEDs for the audio/video module are always on and when the button is pressed all button LEDs light up (see: <a href="#">"Light-me function behaviour on the basis of the LED backlighting mode"</a> )
150	2,3,5,8	Light-me time: 30 sec
151	1,2,3,5,8	Light-me time: 60 sec <b>(default)</b>
152	4,5,8	Light-me time: 120 sec
<b>Restore backup</b>		
114	2,5,6,7	If the audio/video module is replaced, all programming is imported (only available if at least one additional module is connected vi flat cable)
<b>Reset</b>		
115	1,2,5,6,7	<b>Reset button programming:</b> if the modules are addressed (see <a href="#">"Address button modules"</a> ) this resets the programming for the button call addresses
254	2,3,4,5,6,7,8	<b>Reset special programming:</b> restore all the parameters described in this table to their default values

# Twilight sensor

## Button backlighting management



The twilight sensor is in **AUTO** mode by default: the button LEDs light up at night and switch off during the day. To change the setting to **ON** (LEDs always on) or **OFF** (LEDs always off), proceed as follows:

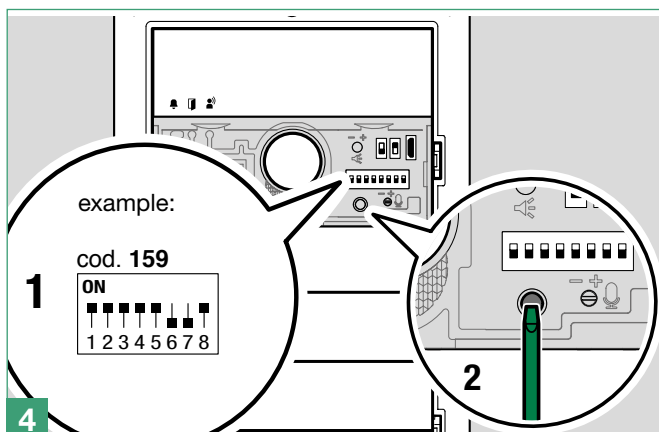
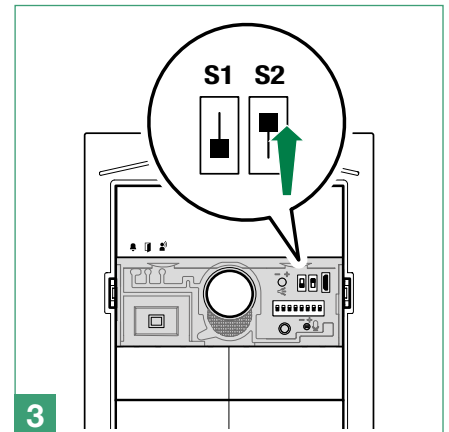
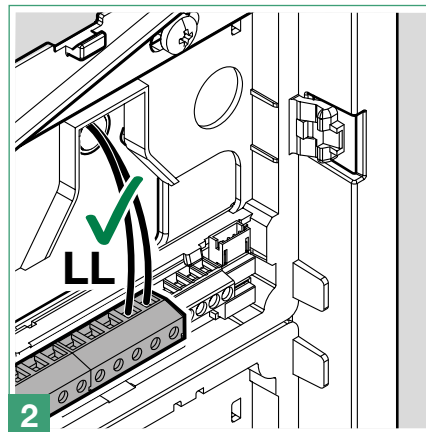
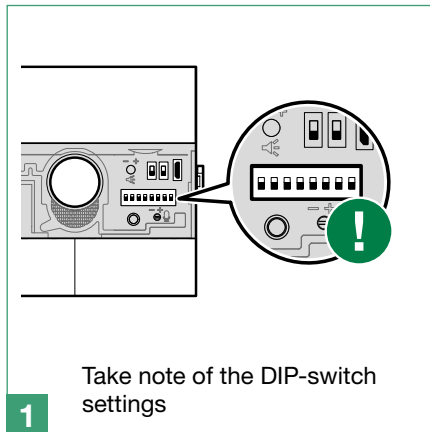

Set the desired backlighting mode (OFF, ON or AUTO) and press the confirm button.

OFF	ON	AUTO (default)
ON 1 2 3 4 5 6 7 8 cod. 158	ON 1 2 3 4 5 6 7 8 cod. 159	ON 1 2 3 4 5 6 7 8 cod. 160

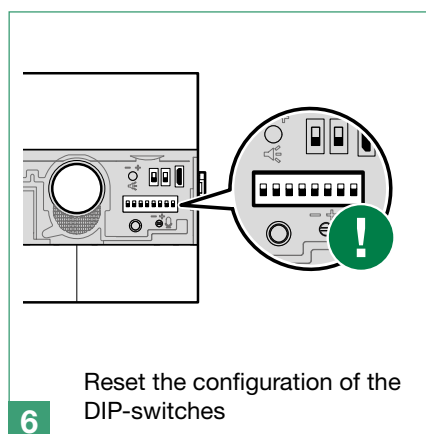
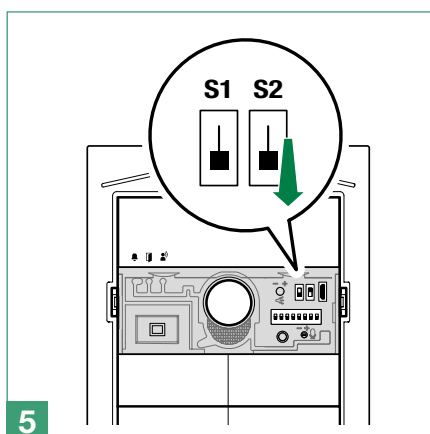

When programming is complete, make sure the button configuration is correct (single/dual), see [“Configure button type \(single/dual\)”](#)



**NOTE:** when the **OFF** and **AUTO** lighting modes are active, every time the entrance panel is powered, the buttons light up for the duration of the start-up phase (10 seconds maximum).

In **AUTO** mode the twilight sensor checks the ambient light level every 9 minutes; if the measured values exceed the specified minimum/maximum thresholds, it is activated/deactivated accordingly.

## Checking twilight sensor operation

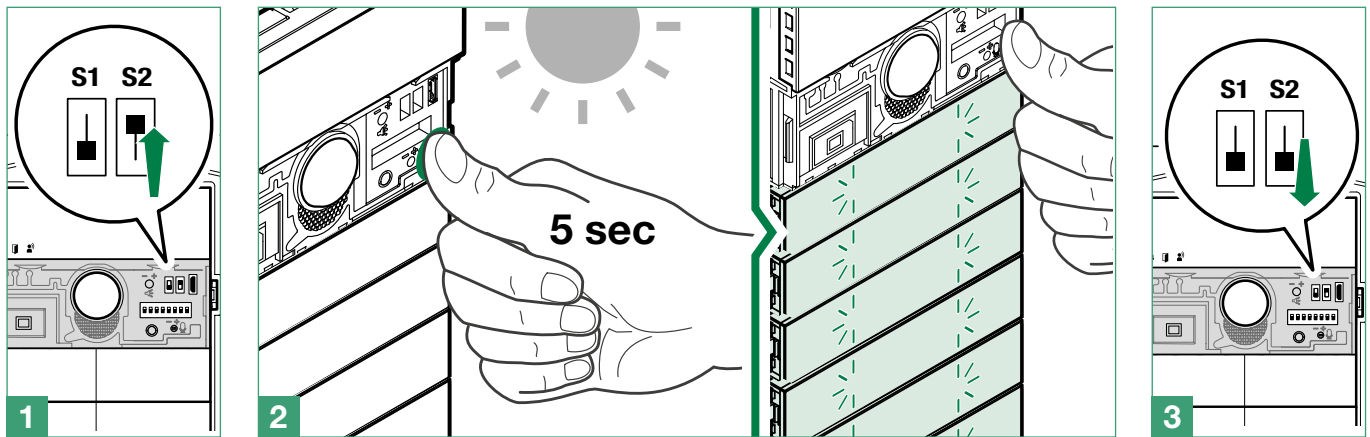

If it is daytime and you want to check AUTO mode operation for the twilight sensor, you can proceed as follows:

1. Enter programming mode
2. Block the twilight sensor for 5 seconds
  - » If AUTO mode has been set, the camera and button LEDs will come on.
3. Exit programming



## Adjusting the brightness of the button LEDs

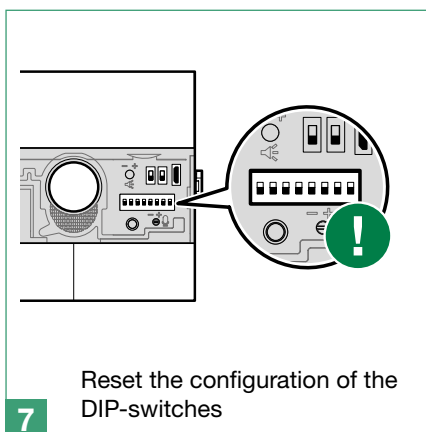
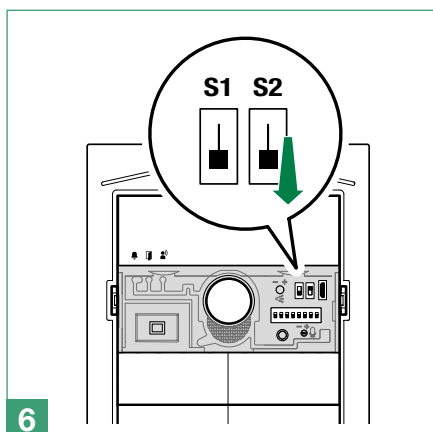
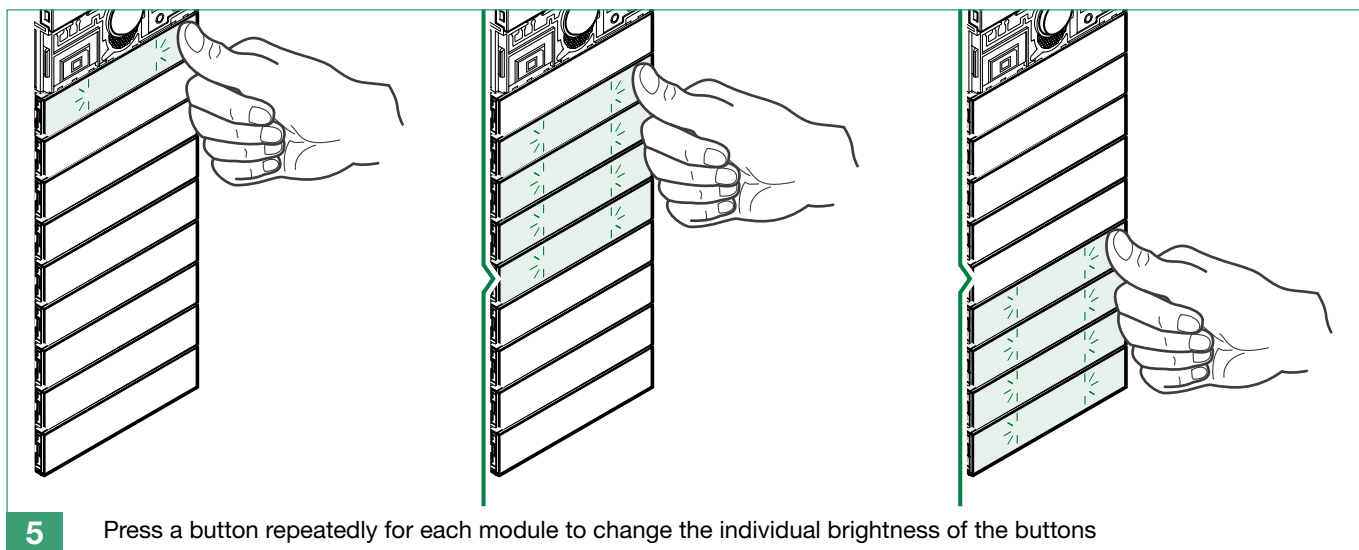
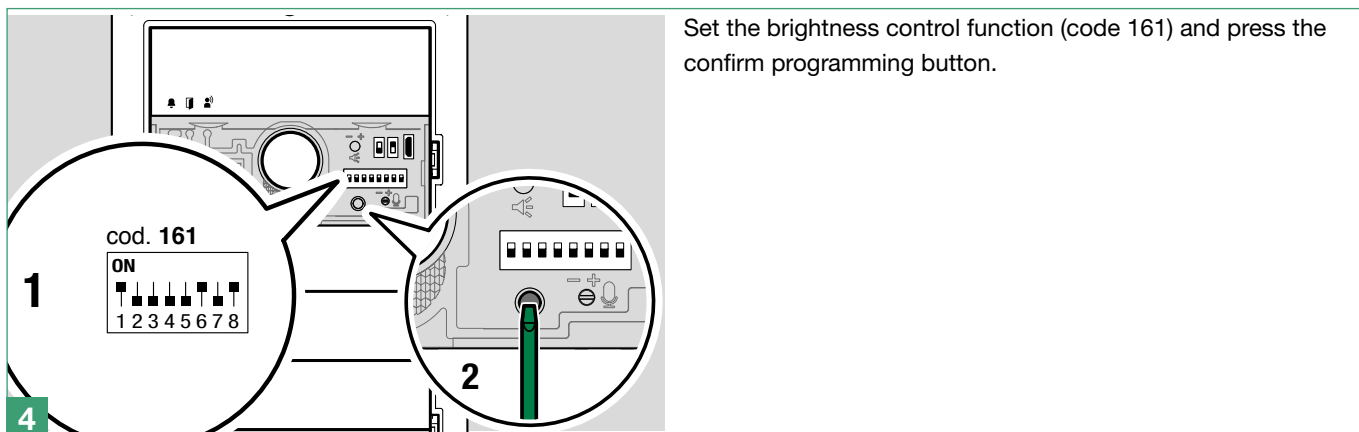
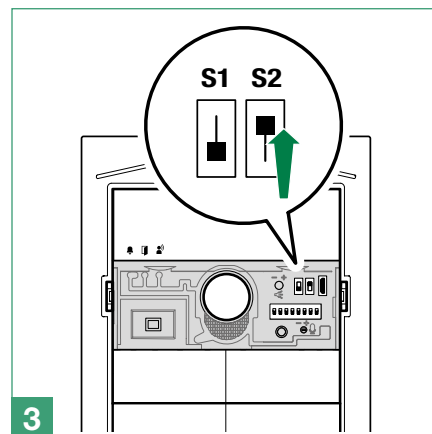
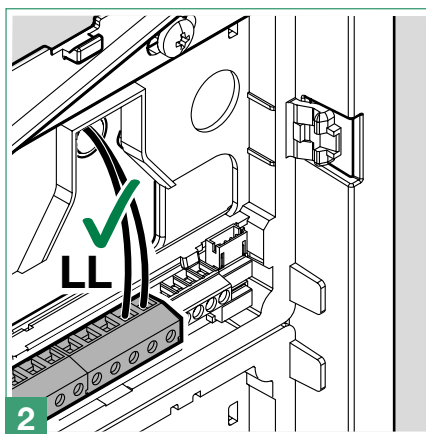
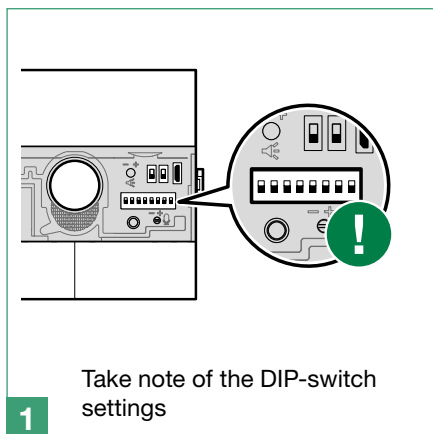

**!** When programming is complete, make sure the button configuration is correct (single/dual), see [“Configure button type \(single/dual\)”](#)

# Light-me function

Thanks to this function, button backlighting is only enabled on the user's request, by pressing the LIGHT-ME button on the audio/video module; this saves energy and reduces light pollution.

Backlighting management for this button depends on the twilight sensor setting. It is in AUTO mode by default: the LEDs light up at night and switch off during the day. It can be set to ON (LEDs always on) or OFF (LEDs always off).

## Light-me function behaviour on the basis of the LED backlighting mode

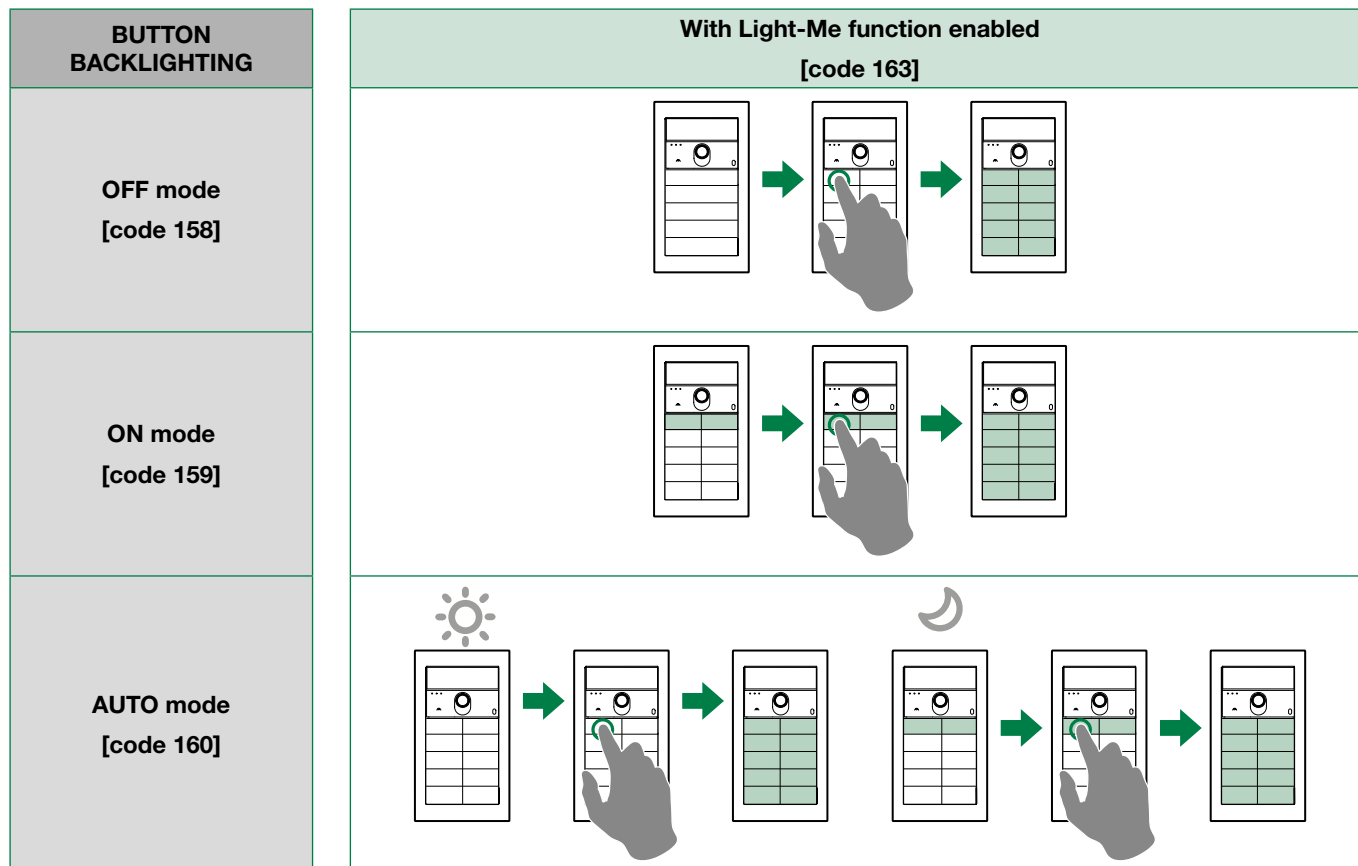

# Replacing the audio module with programming restore backup



If the audio or audio/video module is replaced, the following instructions must be observed. The procedure should be completed within one hour of removal of the old module.

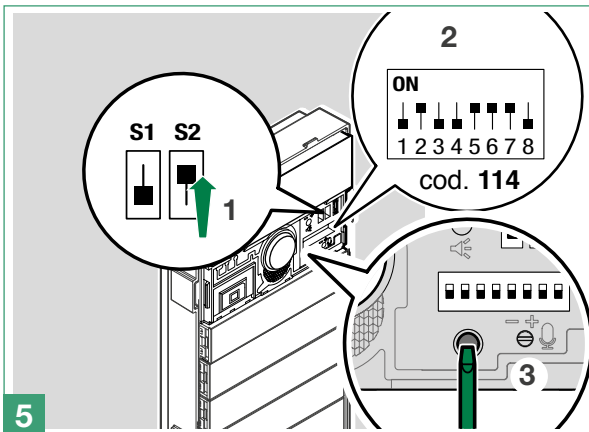
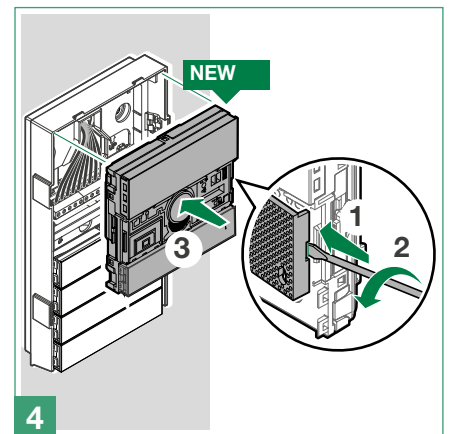
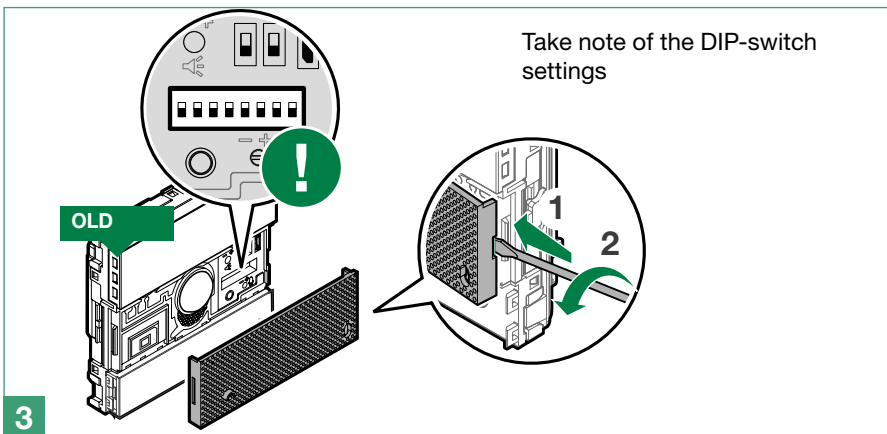
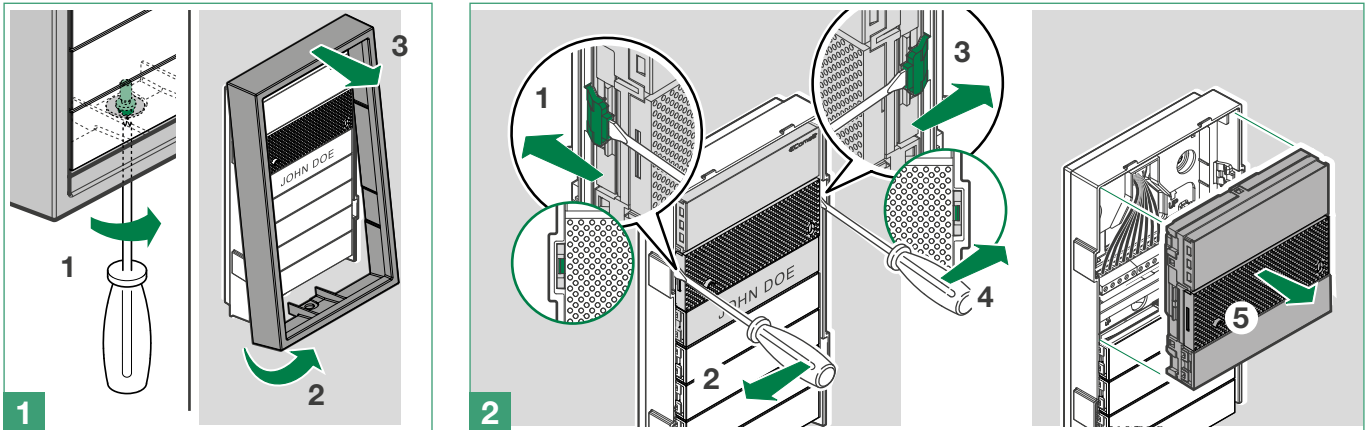

1. Enter programming mode by moving **S2** DIP-switch upwards
  - » the red "system busy" LED flashes for the duration of the procedure
2. Set special programming **114** to import all the programming settings
3. Press the confirm programming button
  - » the green "lock-release" LED will start flashing
  - » at the end of the backup (approx. 30 sec.):
    - » the green "lock-release" LED switches off
    - » the green "audio enabled" LED comes on for a few seconds.

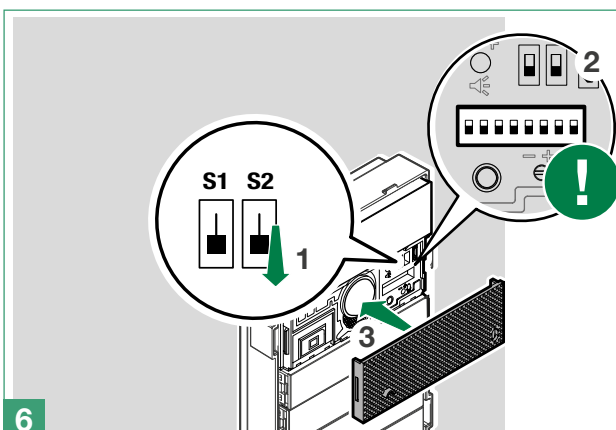

1. Exit programming mode by moving the **S2** DIP-switch downwards
  - » the red "system busy" LED switches off
2. Reset the configuration of the DIP-switches
3. Reattach the front panel



# Configuring via PC

All device configurations can be performed via PC and ViP Manager configuration software, available to download free of charge from [pro.comelitgroup.com](http://pro.comelitgroup.com).

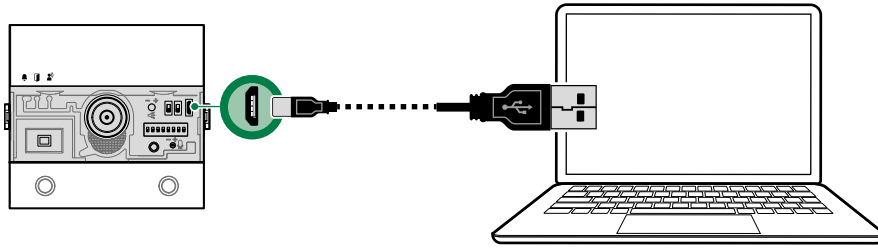
✓ You will need a USB micro-USB cable.



## Errors and indications

	INDICATION	SOLUTION
<b>RED LED  LIT STEADILY + DISSUASION TONE</b>	Line short-circuit	Check connections
	Dual power supply present	Remove jumper J4 on the audio module
	Button modules with the same ID	Check the module IDs
	Programming selector positioning error	Check the position of selectors S1 and S2 (they cannot both be set to ON)
<b>RED LED  FLASHING</b>	Device in programming	

## System performance and layouts

For further information regarding system performance and to view installation layouts, click on the system type:

- [Simplebus2 audio](#)

# Addressing table

Code	Dip switch ON														
1	1	31	1,2,3,4,5	61	1,3,4,5,6	91	1,2,4,5,7	121	1,4,5,6,7	151	1,2,3,5,8	181	1,3,5,6,8	211	1,2,5,7,8
2	2	32	6	62	2,3,4,5,6	92	3,4,5,7	122	2,4,5,6,7	152	4,5,8	182	2,3,5,6,8	212	3,5,7,8
3	1.2	33	1.6	63	1,2,3,4,5,6	93	1,3,4,5,7	123	1,2,4,5,6,7	153	1,4,5,8	183	1,2,3,5,6,8	213	1,3,5,7,8
4	3	34	2.6	64	7	94	2,3,4,5,7	124	3,4,5,6,7	154	2,4,5,8	184	4,5,6,8	214	2,3,5,7,8
5	1.3	35	1,2,6	65	1.7	95	1,2,3,4,5,7	125	1,3,4,5,6,7	155	1,2,4,5,8	185	1,4,5,6,8	215	1,2,3,5,7,8
6	2.3	36	3.6	66	2.7	96	6.7	126	2,3,4,5,6,7	156	3,4,5,8	186	2,4,5,6,8	216	4,5,7,8
7	1,2,3	37	1,3,6	67	1,2,7	97	1,6,7	127	1,2,3,4,5,6,7	157	1,3,4,5,8	187	1,2,4,5,6,8	217	1,4,5,7,8
8	4	38	2,3,6	68	3.7	98	2,6,7	128	8	158	2,3,4,5,8	188	3,4,5,6,8	218	2,4,5,7,8
9	1.4	39	1,2,3,6	69	1,3,7	99	1,2,6,7	129	1.8	159	1,2,3,4,5,8	189	1,3,4,5,6,8	219	1,2,4,5,7,8
10	2.4	40	4.6	70	2,3,7	100	3,6,7	130	2.8	160	6.8	190	2,3,4,5,6,8	220	3,4,5,7,8
11	1,2,4	41	1,4,6	71	1,2,3,7	101	1,3,6,7	131	1,2,8	161	1,6,8	191	1,2,3,4,5,6,8	221	1,3,4,5,7,8
12	3.4	42	2,4,6	72	4.7	102	2,3,6,7	132	3.8	162	2,6,8	192	7.8	222	2,3,4,5,7,8
13	1,3,4	43	1,2,4,6	73	1,4,7	103	1,2,3,6,7	133	1,3,8	163	1,2,6,8	193	1,7,8	223	1,2,3,4,5,7,8
14	2,3,4	44	3,4,6	74	2,4,7	104	4,6,7	134	2,3,8	164	3,6,8	194	2,7,8	224	6,7,8
15	1,2,3,4	45	1,3,4,6	75	1,2,4,7	105	1,4,6,7	135	1,2,3,8	165	1,3,6,8	195	1,2,7,8	225	1,6,7,8
16	5	46	2,3,4,6	76	3,4,7	106	2,4,6,7	136	4.8	166	2,3,6,8	196	3,7,8	226	2,6,7,8
17	1.5	47	1,2,3,4,6	77	1,3,4,7	107	1,2,4,6,7	137	1,4,8	167	1,2,3,6,8	197	1,3,7,8	227	1,2,6,7,8
18	2.5	48	5.6	78	2,3,4,7	108	3,4,6,7	138	2,4,8	168	4,6,8	198	2,3,7,8	228	3,6,7,8
19	1,2,5	49	1,5,6	79	1,2,3,4,7	109	1,3,4,6,7	139	1,2,4,8	169	1,4,6,8	199	1,2,3,7,8	229	1,3,6,7,8
20	3.5	50	2,5,6	80	5.7	110	2,3,4,6,7	140	3,4,8	170	2,4,6,8	200	4,7,8	230	2,3,6,7,8
21	1,3,5	51	1,2,5,6	81	1,5,7	111	1,2,3,4,6,7	141	1,3,4,8	171	1,2,4,6,8	201	1,4,7,8	231	1,2,3,6,7,8
22	2,3,5	52	3,5,6	82	2,5,7	112	5.6,7	142	2,3,4,8	172	3,4,6,8	202	2,4,7,8	232	4,6,7,8
23	1,2,3,5	53	1,3,5,6	83	1,2,5,7	113	1,5,6,7	143	1,2,3,4,8	173	1,3,4,6,8	203	1,2,4,7,8	233	1,4,6,7,8
24	4.5	54	2,3,5,6	84	3,5,7	114	2,5,6,7	144	5.8	174	2,3,4,6,8	204	3,4,7,8	234	2,4,6,7,8
25	1,4,5	55	1,2,3,5,6	85	1,3,5,7	115	1,2,5,6,7	145	1,5,8	175	1,2,3,4,6,8	205	1,3,4,7,8	235	1,2,4,6,7,8
26	2,4,5	56	4,5,6	86	2,3,5,7	116	3,5,6,7	146	2,5,8	176	5,6,8	206	2,3,4,7,8	236	3,4,6,7,8
27	1,2,4,5	57	1,4,5,6	87	1,2,3,5,7	117	1,3,5,6,7	147	1,2,5,8	177	1,5,6,8	207	1,2,3,4,7,8	237	1,3,4,6,7,8
28	3,4,5	58	2,4,5,6	88	4,5,7	118	2,3,5,6,7	148	3,5,8	178	2,5,6,8	208	5,7,8	238	2,3,4,6,7,8
29	1,3,4,5	59	1,2,4,5,6	89	1,4,5,7	119	1,2,3,5,6,7	149	1,3,5,8	179	1,2,5,6,8	209	1,5,7,8	239	1,2,3,4,6,7,8
30	2,3,4,5	60	3,4,5,6	90	2,4,5,7	120	4,5,6,7	150	2,3,5,8	180	3,5,6,8	210	2,5,7,8	*240	5,6,7,8

\* NOTE: Code 240 is reserved for the porter switchboard

CERTIFIED MANAGEMENT SYSTEMS



[www.comelitgroup.com](http://www.comelitgroup.com)

Via Don Arrigoni, 5 - 24020 Rovetta (BG) - Italy

 **Comelit**<sup>®</sup>  
Passion. Technology. Design.