

# FERMAX



MANUAL DE INSTALADOR INSTALLER'S MANUAL MANUEL D'INSTALLATION  
INSTALLATIONSHANDBUCH MANUAL DO INSTALADOR MANUAL DE INSTAL  
ADADOR MANUAL DE INSTALADOR INSTALLER'S MANUA  
LATION INSTALLATIONSHANDBUCH MANUAL DO INSTALA  
STALADOR INSTALLER'S MANUAL MANUEL D'INSTALLATION  
SHANDBUCH MANUAL DO INSTALADOR MANUAL DE INSTAL  
MANUAL MANUEL D'INSTALLATION INSTALLATIONSHANDBUC  
H MANUAL DO INSTALADOR MANUAL DE INSTALADOR INSTALLER'S MANUA  
LATION INSTALLATIONSHANDBUCH MANUAL DO INSTALA  
STALADOR INSTALLER'S MANUAL MANUEL D'INSTALLATION

**PLACA VDS**  
**VDS OUTDOOR PANEL**  
**PLATINE VDS**  
**VDS TÜRSTATION**  
**PLACA VDS**

MANUAL DE INSTALADOR  
INSTALLER'S MANUAL  
MANUEL D'INSTALLATION  
INSTALLATIONSHANDBUCH  
MANUAL DO INSTALADOR



ESPAÑOL  
ENGLISH  
FRANÇAIS  
DEUTSCH  
PORTUGUÊS

# FERMAX



MANUAL DE INSTALADOR INSTALLER'S MANUAL MANUEL D'INSTALLATION  
INSTALLATIONSHANDBUCH MANUAL DO INSTALADOR MANUAL DE INSTAL  
ADADOR MANUAL DE INSTALADOR INSTALLER'S MANUA  
LATION INSTALLATIONSHANDBUCH MANUAL DO INSTALA  
STALADOR INSTALLER'S MANUAL MANUEL D'INSTALLATION  
SHANDBUCH MANUAL DO INSTALADOR MANUAL DE INSTAL  
MANUAL MANUEL D'INSTALLATION INSTALLATIONSHANDBUC  
H MANUAL DO INSTALADOR MANUAL DE INSTALADOR INSTALLER'S MANUA  
LATION INSTALLATIONSHANDBUCH MANUAL DO INSTALA  
STALADOR INSTALLER'S MANUAL MANUEL D'INSTALLATION

**PLACA VDS**  
**VDS OUTDOOR PANEL**  
**PLATINE VDS**  
**VDS TÜRSTATION**  
**PLACA VDS**

MANUAL DE INSTALADOR  
INSTALLER'S MANUAL  
MANUEL D'INSTALLATION  
INSTALLATIONSHANDBUCH  
MANUAL DO INSTALADOR



ESPAÑOL  
ENGLISH  
FRANÇAIS  
DEUTSCH  
PORTUGUÊS

**E ENHORABUENA POR DISPONER DE UN PRODUCTO DE CALIDAD!**

Fermax electrónica desarrolla y fabrica equipos de prestigio que cumplen los más altos estándares de diseño y tecnología. Esperamos disfrute de sus funcionalidades.

**EN CONGRATULATIONS ON PURCHASING THIS QUALITY PRODUCT!**

Fermax Electronics develops and manufactures reputable equipment which fulfils the highest design and technology standards. We hope you enjoy its range of functions.

**F FÉLICITATIONS ! VOUS VENEZ D'ACQUÉRIR UN VÉRITABLE PRODUIT DE QUALITÉ!**

Fermax Electrónica développe et fabrique des équipements de prestige qui répondent aux normes de design et technologie les plus développées. Nous espérons que vous profiterez pleinement de toutes ses fonctions.

**D WIR GRATULIEREN IHNEN ZUM KAUF DIESES QUALITÄTSPRODUKTS!**

Fermax Electrónica entwickelt und fabriziert hochwertige Anlagen, die den höchsten Technologie- und Designstandards entsprechen. Überzeugende Funktionalität für Ihr Eigenheim!

**P PARABÉNS POR DISPOR DE UM PRODUTO DE QUALIDADE!**

Fermax electrónica desenvolve e fabrica equipamentos de prestígio que cumprem com os mais altos padrões de desenho e tecnologia. Esperamos que desfrute das suas funcionalidades.

Cod. 97616 V10\_10

Pag 2

**E ENHORABUENA POR DISPONER DE UN PRODUCTO DE CALIDAD!**

Fermax electrónica desarrolla y fabrica equipos de prestigio que cumplen los más altos estándares de diseño y tecnología. Esperamos disfrute de sus funcionalidades.

**EN CONGRATULATIONS ON PURCHASING THIS QUALITY PRODUCT!**

Fermax Electronics develops and manufactures reputable equipment which fulfils the highest design and technology standards. We hope you enjoy its range of functions.

**F FÉLICITATIONS ! VOUS VENEZ D'ACQUÉRIR UN VÉRITABLE PRODUIT DE QUALITÉ!**

Fermax Electrónica développe et fabrique des équipements de prestige qui répondent aux normes de design et technologie les plus développées. Nous espérons que vous profiterez pleinement de toutes ses fonctions.

**D WIR GRATULIEREN IHNEN ZUM KAUF DIESES QUALITÄTSPRODUKTS!**

Fermax Electrónica entwickelt und fabriziert hochwertige Anlagen, die den höchsten Technologie- und Designstandards entsprechen. Überzeugende Funktionalität für Ihr Eigenheim!

**P PARABÉNS POR DISPOR DE UM PRODUTO DE QUALIDADE!**

Fermax electrónica desenvolve e fabrica equipamentos de prestígio que cumprem com os mais altos padrões de desenho e tecnologia. Esperamos que desfrute das suas funcionalidades.

Cod. 97616 V10\_10

Pag 2

## INDICE - INDEX - SOMMAIRE - INHALT - INDICE

<b>E</b> AMPLIFIADOR ADS/VDS .....	4
Instalación del amplificador .....	4
Conectores / Ajustes / Reset a valores de fábrica .....	6
Precableado .....	15
Características Técnicas .....	16
Cableado .....	17
<b>EN</b> ADS/VDS AMPLIFIER .....	4
Amplifier installation .....	4
Connectors / adjustment / Reset a valores de fábrica .....	6
Internal wiring .....	15
Technical Features .....	16
Wiring .....	17
<b>F</b> AMPLIFICATEUR ADS/VDS .....	4
Installation du amplificateur .....	4
Connecteurs / Réglages / Reset a valores de fábrica .....	6
Précâblage .....	15
Caractéristiques techniques .....	16
Câblage .....	17
<b>D</b> ADS/VDS-VERSTÄRKER .....	4
Installation des Netzgeräts .....	4
Anschlüsse / Einstellungen / Nullstellung auf werksseitige Parameter .....	6
Vorverkabelung .....	15
Technische Eigenschaften .....	16
Verkabelung .....	17
<b>P</b> AMPLIFICADOR ADS/VDS .....	4
Instalação do amplificador .....	4
Conectores / Ajustes / Reset para valores de fábrica .....	6
Pré-cablagem .....	15
Características Técnicas .....	16
Cablagem .....	17

## INDICE - INDEX - SOMMAIRE - INHALT - INDICE

<b>E</b> AMPLIFIADOR ADS/VDS .....	4
Instalación del amplificador .....	4
Conectores / Ajustes / Reset a valores de fábrica .....	6
Precableado .....	15
Características Técnicas .....	16
Cableado .....	17
<b>EN</b> ADS/VDS AMPLIFIER .....	4
Amplifier installation .....	4
Connectors / adjustment / Reset a valores de fábrica .....	6
Internal wiring .....	15
Technical Features .....	16
Wiring .....	17
<b>F</b> AMPLIFICATEUR ADS/VDS .....	4
Installation du amplificateur .....	4
Connecteurs / Réglages / Reset a valores de fábrica .....	6
Précâblage .....	15
Caractéristiques techniques .....	16
Câblage .....	17
<b>D</b> ADS/VDS-VERSTÄRKER .....	4
Installation des Netzgeräts .....	4
Anschlüsse / Einstellungen / Nullstellung auf werksseitige Parameter .....	6
Vorverkabelung .....	15
Technische Eigenschaften .....	16
Verkabelung .....	17
<b>P</b> AMPLIFICADOR ADS/VDS .....	4
Instalação do amplificador .....	4
Conectores / Ajustes / Reset para valores de fábrica .....	6
Pré-cablagem .....	15
Características Técnicas .....	16
Cablagem .....	17

**VDS Panels**

**FERMAX**

- E** AMPLIFICADOR ADS/VDS
- F** AMPLIFICATEUR ADS/VDS
- P** AMPLIFICADOR ADS/VDS

- EN** ADS/VDS AMPLIFIER
- D** ADS/VDS VERSTÄRKER

**AUDIO**

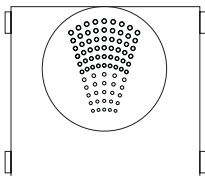

**VIDEO**

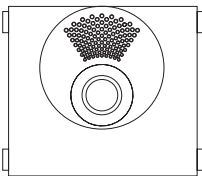

- E** INSTALACIÓN PLACA
- EN** PANEL INSTALLATION
- F** INSTALLATION PLATINE
- D** INSTALLATION TÛRTATION
- P** INSTALAÇÃO DO PLACA

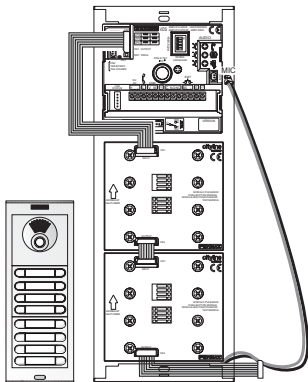

**VDS Panels**

**FERMAX**

- E** AMPLIFICADOR ADS/VDS
- F** AMPLIFICATEUR ADS/VDS
- P** AMPLIFICADOR ADS/VDS

- EN** ADS/VDS AMPLIFIER
- D** ADS/VDS VERSTÄRKER

**AUDIO**

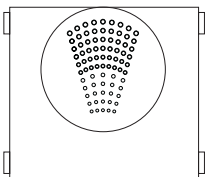

**VIDEO**

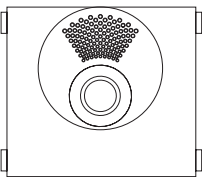

- E** INSTALACIÓN PLACA
- EN** PANEL INSTALLATION
- F** INSTALLATION PLATINE
- D** INSTALLATION TÛRTATION
- P** INSTALAÇÃO DO PLACA

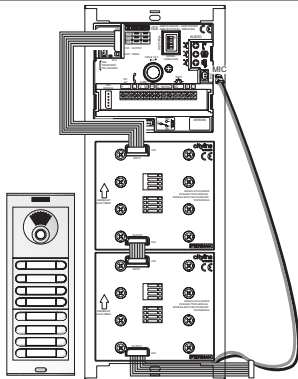



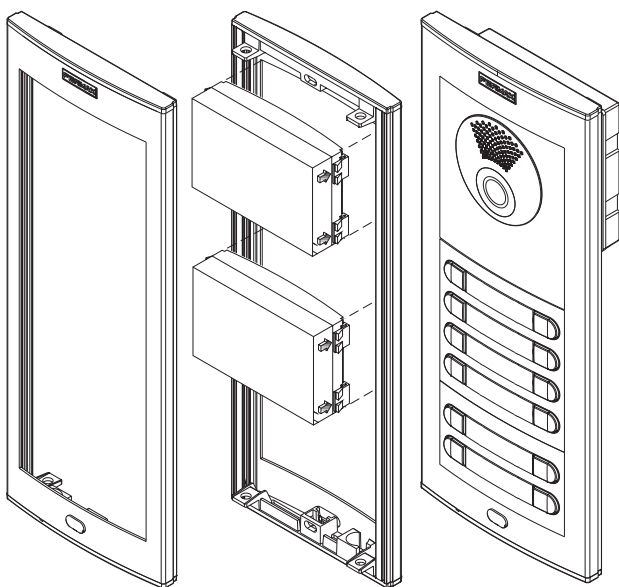
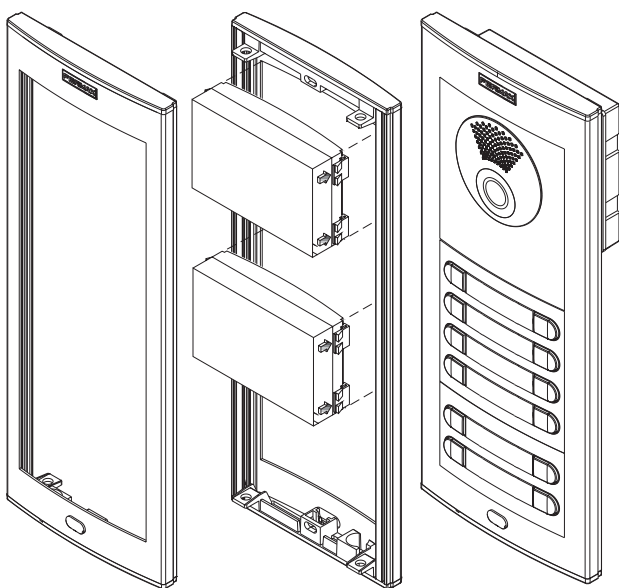

**E** CONECTORES/AJUSTES  
**F** CONNECTEURS/RÉGLAGES  
**P** CONECTORES/AJUSTES

**EN** CONNECTORS/ADJUSTMENT  
**D** ANSCHLÜSSE/EINSTELLUNGEN

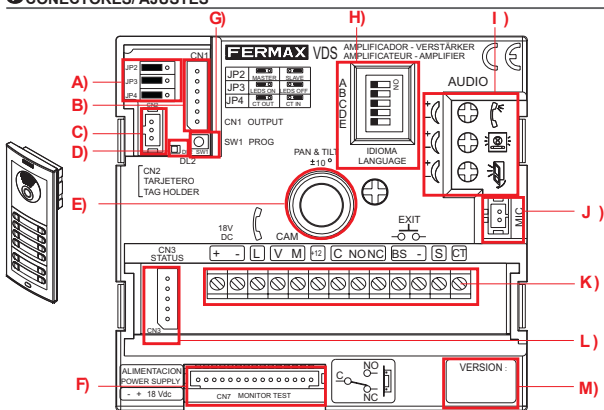

**A)**

JP2	<input checked="" type="checkbox"/> <input type="checkbox"/> (*)	<input type="checkbox"/> <input checked="" type="checkbox"/>
<b>E</b> Selección Placa Principal / Placa Secundaria	Placa Principal	Placa Secundaria
<b>EN</b> Main Panel/Secondary Panel Selection	Main Panel	Secondary Panel
<b>F</b> Sélection de la platine principale / platine secondaire	Platine principale	Platine secondaire
<b>D</b> Auswahl Haupttürstation / Nebentürstation	Haupttürstation	Nebentürstation
<b>P</b> Seleção de Placa Principal / Placa Secundária	Placa Principal	Placa Secundária

(\*) Configuración por defecto: Placa Principal - Default Configuration: Main Panel - Configuration par défaut: platine principale - Standardkonfiguration: Haupttürstation - Configuração por defeito: Placa Principal

JP3	<input checked="" type="checkbox"/> <input type="checkbox"/>	<input type="checkbox"/> <input checked="" type="checkbox"/>
<b>E</b> Leds cámara	encendidos cuando la cámara está activada	apagados siempre
<b>EN</b> Camera LEDs	ON when the camera is active	always off
<b>F</b> DEL de la cámara	ON quand la caméra est activée	toujours éteintes
<b>D</b> Leuchtdioden der Kamera	ON wenn die Kamera aktiv ist	immer ausgeschaltet
<b>P</b> Leds de câmara	ON quando a câmara está activada.	sempre apagados

**E** CONECTORES/AJUSTES  
**F** CONNECTEURS/RÉGLAGES  
**P** CONECTORES/AJUSTES

**EN** CONNECTORS/ADJUSTMENT  
**D** ANSCHLÜSSE/EINSTELLUNGEN

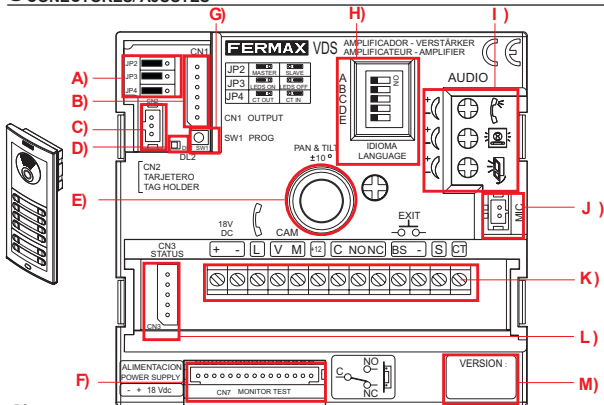

**A)**

JP2	<input checked="" type="checkbox"/> <input type="checkbox"/> (*)	<input type="checkbox"/> <input checked="" type="checkbox"/>
<b>E</b> Selección Placa Principal / Placa Secundaria	Placa Principal	Placa Secundaria
<b>EN</b> Main Panel/Secondary Panel Selection	Main Panel	Secondary Panel
<b>F</b> Sélection de la platine principale / platine secondaire	Platine principale	Platine secondaire
<b>D</b> Auswahl Haupttürstation / Nebentürstation	Haupttürstation	Nebentürstation
<b>P</b> Seleção de Placa Principal / Placa Secundária	Placa Principal	Placa Secundária

(\*) Configuración por defecto: Placa Principal - Default Configuration: Main Panel - Configuration par défaut: platine principale - Standardkonfiguration: Haupttürstation - Configuração por defeito: Placa Principal

JP3	<input checked="" type="checkbox"/> <input type="checkbox"/>	<input type="checkbox"/> <input checked="" type="checkbox"/>
<b>E</b> Leds cámara	encendidos cuando la cámara está activada	apagados siempre
<b>EN</b> Camera LEDs	ON when the camera is active	always off
<b>F</b> DEL de la cámara	ON quand la caméra est activée	toujours éteintes
<b>D</b> Leuchtdioden der Kamera	ON wenn die Kamera aktiv ist	immer ausgeschaltet
<b>P</b> Leds de câmara	ON quando a câmara está activada.	sempre apagados

JP4		
CT: Activación cámara/salida auxiliar	CT: salida 11 Vdc	CT: entrada Conectar 12 Vdc para activar permanentemente cámara+ leds
CT: Camera activation/auxiliary output	CT: 11 Vdc output	CT: input Connect 12 Vdc to permanently activate camera + LEDs
CT : Activation caméra / sortie auxiliaire	CT : sortie 11 Vcc	CT : entrée Connecter 12 Vcc pour activer en permanence caméra + leds
CT: Kameraaktivierung/ Nebenausgang	CT: 11 VDC Ausgang	CT: Eingang 12 VDC NG anschließen um Kamera und LEDs permanent zu aktivieren
CT: Activação da câmara/salida auxiliar	CT: saída de 11 VDC	CT: entrada Ligar 12 VDC para activar permanentemente a câmara+ LEDs

**B)**

CN1	<ul style="list-style-type: none"> <li><b>E</b> Conexión pulsadores modulares, teclado, display.</li> <li><b>EN</b> Connection modular buttons, keypad, display.</li> <li><b>F</b> Connexion boutons-poussoirs modulaires, clavier, affichage.</li> <li><b>D</b> Anschluss Tastenmodule, Tastatur, Display.</li> <li><b>P</b> Ligaçao do botões modulares, teclado, display.</li> </ul>
-----	---

**C)**

CN2	<b>L+ / L-</b>	<b>CP</b>
<b>E</b> Conexión iluminación tarjeteros y pulsadores	Luz tarjetero pulsador	Común de pulsadores
<b>EN</b> Connection card holder and button lighting	Cardholder Backlight	Common Button Wire
<b>F</b> Connexion éclairage boutons-poussoirs et porte-étiquettes	Lumière porte-étiquettes bouton-poussoir	Connecteur commun de boutons-poussoirs
<b>D</b> Anschluss Tasten- und Infomodul-Beleuchtung	Beleuchtung Taste Infomodul	Gemeinsamer Draht der Klingeltasten
<b>P</b> Ligaçao de iluminação dos porta-cartões e botões	Luz do porta-cartões do botão	Comum de botões

**D)**

DL2	<ul style="list-style-type: none"> <li><b>E</b> Led Diagnóstico Si existe un cortocircuito entre + y L, al llamar desde placa emite una serie de destellos cortos</li> <li><b>EN</b> Diagnostic Led If there is a short circuit between + and L, when a call is made from the panel, it emits a series of short flashes</li> <li><b>F</b> Diagnostic Del S'il existe un court-circuit entre + e L lors d'un appel de la platine, elle émet une série de brefs clignotements</li> <li><b>D</b> Diagnose-LED Falls ein Kurzschluss zwischen + und L bei der Durchführung eines Anrufs, blinkt diese mehrmals kurz auf</li> <li><b>P</b> Led diagnóstico Se existir um curto-circuito entre + e L, ao realizar uma chamada a partir da placa emite luz intermitente rápida</li> </ul>
-----	--

**E)**

- E** Enfoque la telecámara
- EN** Focus the camera
- F** Réglez la caméra vidéo
- D** Richten Sie die Kamera aus
- P** Foque a telecámara.

Pan & Tilt ( $\pm 10^\circ$ )

Pag 7

JP4		
CT: Activación cámara/salida auxiliar	CT: salida 11 Vdc	CT: entrada Conectar 12 Vdc para activar permanentemente cámara+ leds
CT: Camera activation/auxiliary output	CT: 11 Vdc output	CT: input Connect 12 Vdc to permanently activate camera + LEDs
CT : Activation caméra / sortie auxiliaire	CT : sortie 11 Vcc	CT : entrée Connecter 12 Vcc pour activer en permanence caméra + leds
CT: Kameraaktivierung/ Nebenausgang	CT: 11 VDC Ausgang	CT: Eingang 12 VDC NG anschließen um Kamera und LEDs permanent zu aktivieren
CT: Activação da câmara/salida auxiliar	CT: saída de 11 VDC	CT: entrada Ligar 12 VDC para activar permanentemente a câmara+ LEDs

**B)**

CN1	<ul style="list-style-type: none"> <li><b>E</b> Conexión Módulo de extensión de llamadas, pulsadores modulares, teclado, display o hasta 3 pulsadores (placa kit)</li> <li><b>EN</b> Connection call extension module, modular buttons, keypad, display or up to 3 buttons (panel kit)</li> <li><b>F</b> Connexion Module d'extension d'appel, boutons-poussoirs modulaires, clavier, affichage ou jusqu'à 3 boutons-poussoirs (platine kit)</li> <li><b>D</b> Anschluss Ruferweiterungsmodul, Tastenmodule, Tastatur, Display oder bis zu 3 Tasten (Türstation-Set)</li> <li><b>P</b> Ligaçao do Módulo de extensão de chamadas, botões modulares, teclado, display ou até 3 botões (placa de kit)</li> </ul>
-----	--

**C)**

CN2	<b>L+ / L-</b>	<b>CP</b>
<b>E</b> Conexión iluminación tarjeteros y pulsadores	Luz tarjetero pulsador	Común de pulsadores
<b>EN</b> Connection card holder and button lighting	Cardholder Backlight	Common Button Wire
<b>F</b> Connexion éclairage boutons-poussoirs et porte-étiquettes	Lumière porte-étiquettes bouton-poussoir	Connecteur commun de boutons-poussoirs
<b>D</b> Anschluss Tasten- und Infomodul-Beleuchtung	Beleuchtung Taste Infomodul	Gemeinsamer Draht der Klingeltasten
<b>P</b> Ligaçao de iluminação dos porta-cartões e botões	Luz do porta-cartões do botão	Comum de botões

**D)**

DL2	<ul style="list-style-type: none"> <li><b>E</b> Led Diagnóstico Si existe un cortocircuito entre + y L, al llamar desde placa emite una serie de destellos cortos</li> <li><b>EN</b> Diagnostic Led If there is a short circuit between + and L, when a call is made from the panel, it emits a series of short flashes</li> <li><b>F</b> Diagnostic Del S'il existe un court-circuit entre + e L lors d'un appel de la platine, elle émet une série de brefs clignotements</li> <li><b>D</b> Diagnose-LED Falls ein Kurzschluss zwischen + und L bei der Durchführung eines Anrufs, blinkt diese mehrmals kurz auf</li> <li><b>P</b> Led diagnóstico Se existir um curto-circuito entre + e L, ao realizar uma chamada a partir da placa emite luz intermitente rápida</li> </ul>
-----	--

**E)**

- E** Enfoque la telecámara
- EN** Focus the camera
- F** Réglez la caméra vidéo
- D** Richten Sie die Kamera aus
- P** Foque a telecámara.

Pan & Tilt ( $\pm 10^\circ$ )

Pag 7

F)

CN7

<b>E</b> Video Test monitor	Conector de test y programación de monitores
<b>EN</b> Video test monitor	Test and monitor programming connector
<b>F</b> Écran de Test Vidéo	Connecteur de test et programmation d'écrans
<b>D</b> Video Testmonitor	Testanschluss und Monitorprogrammierung
<b>P</b> Video Test monitor	Conector de teste e programação de monitores

G)

SW1

<b>E</b> Mapeado: botón para entrar en modo programación de pulsadores. Ver manual "Mapeado"
<b>EN</b> Mapping: button to enter button programming mode. See manual 'Mapping'
<b>F</b> Mappage : bouton pour entrer en mode programmation de boutons-poussoirs. Voir manuel « Mappage »
<b>D</b> Mapping: Programmieraste der Klingeltasten Siehe Handbuch "Mapping"
<b>P</b> Mapeamento: botão para aceder ao modo de programação de botões. Ver o manual "Mapeamento"

H)



- E** Selección del idioma del mensaje de «puerta abierta».
- EN** Select language for «open door» message.
- F** Sélection de la langue du message « porte ouverte ».
- D** Sprachwahl der Meldung «Tür offen».
- P** Seleçção da língua da mensagem de «porta aberta».

Ver CODIFICACIÓN al final de este manual. See CODIFICATION at the end of this manual. Voir CODIFICATION à la fin de ce manuel. Siehe KODIERUNG am Ende dieses Handbuchs. Ver CODIFICAÇÃO no final deste manual.

I)

- E** Ajuste audio
- EN** Adjust the audio
- F** Réglez le volume
- D** Audioeinstellung
- P** Ajuste o áudio

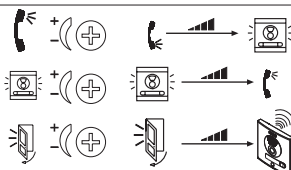

- E** "puerta abierta"
- EN** "open door"
- F** « porte ouverte »
- D** "Tür offen"
- P** "porta aberta"

J)

MIC

<b>E</b> Conexión micrófono (micrófono ubicado en el perfil inferior de la placa)
<b>EN</b> Microphone connection (microphone located in the lower panel profile)
<b>F</b> Connexion microphone (microphone placé sur le profil inférieur de la platine)
<b>D</b> Mikrofonanschluss (Mikrofon befindet sich am unteren Profil der Türstation)
<b>P</b> Ligaçã do microfone (microfone localizado no perfil inferior da placa)

F)

CN7

<b>E</b> Video Test monitor	Conector de test y programación de monitores
<b>EN</b> Video test monitor	Test and monitor programming connector
<b>F</b> Écran de Test Vidéo	Connecteur de test et programmation d'écrans
<b>D</b> Video Testmonitor	Testanschluss und Monitorprogrammierung
<b>P</b> Video Test monitor	Conector de teste e programação de monitores

G)

SW1

<b>E</b> Mapeado: botón para entrar en modo programación de pulsadores. Ver manual "Mapeado"
<b>EN</b> Mapping: button to enter button programming mode. See manual 'Mapping'
<b>F</b> Mappage : bouton pour entrer en mode programmation de boutons-poussoirs. Voir manuel « Mappage »
<b>D</b> Mapping: Programmieraste der Klingeltasten Siehe Handbuch "Mapping"
<b>P</b> Mapeamento: botão para aceder ao modo de programação de botões. Ver o manual "Mapeamento"

H)



- E** Selección del idioma del mensaje de «puerta abierta».
- EN** Select language for «open door» message.
- F** Sélection de la langue du message « porte ouverte ».
- D** Sprachwahl der Meldung «Tür offen».
- P** Seleçção da língua da mensagem de «porta aberta».

Ver CODIFICACIÓN al final de este manual. See CODIFICATION at the end of this manual. Voir CODIFICATION à la fin de ce manuel. Siehe KODIERUNG am Ende dieses Handbuchs. Ver CODIFICAÇÃO no final deste manual.

I)

- E** Ajuste audio
- EN** Adjust the audio
- F** Réglez le volume
- D** Audioeinstellung
- P** Ajuste o áudio

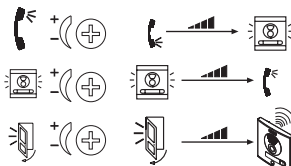

- E** "puerta abierta"
- EN** "open door"
- F** « porte ouverte »
- D** "Tür offen"
- P** "porta aberta"

J)

MIC

<b>E</b> Conexión micrófono (micrófono ubicado en el perfil inferior de la placa)
<b>EN</b> Microphone connection (microphone located in the lower panel profile)
<b>F</b> Connexion microphone (microphone placé sur le profil inférieur de la platine)
<b>D</b> Mikrofonanschluss (Mikrofon befindet sich am unteren Profil der Türstation)
<b>P</b> Ligaçã do microfone (microfone localizado no perfil inferior da placa)

K)

**E Conectores Placa:**

- Bornas de video, (coaxial).  
**V:** vivo  
**M:** malla  
**Ct:** activación telecamara (11 Vdc)
- Bornas de Conexión del sistema:  
**+, -:** alimentación (18 Vdc).  
**L:** bus de datos.  
**+12:** salida 12 Vdc (0,4 A. max).  
**C, NO, NC:** contactos relé  
(conexión abrepuertas)  
**BS, -:** pulsador zaguán.  
**S:** activación del cambiador

**EN Panel Connectors:**

- Video terminals (coaxial):  
**V:** live  
**M:** shield  
**Ct:** camera activation (11 Vdc)
- System connection terminals:  
**+, -:** power supply (18 Vdc).  
**+12:** 12 Vdc output.  
**L:** data bus.  
**C, NO, NC:** relay contacts (door-opener connection)  
**BS, -:** entrance hall button.  
**S:** activation of the exchanger

**F Connecteurs platine:**

- Bornes vidéo (câble coaxial).  
**V:** vif  
**M:** maille  
**Ct:** activation caméra (11 Vdc)
- Bornes de raccordement du système.  
**+, -:** alimentation (18 Vcc).  
**L:** bus de données.  
**+12:** 12 Vcc  
**C, NO (no), NC (nf):** contacts relais (connexion gâche électrique)  
**BS, -:** bouton-poussoir vestibule.  
**S:** activation de l'échangeur.

**D Anschlüsse Türstation:**

- Video-Klemmen (Koaxial)  
**V:** Kern  
**M:** Schirm  
**Ct:** Aktivierung der Kamera (11 VDC)
- Anschlussklemmen des Systems:  
**+, -:** Stromversorgung (18 VDC)  
**L:** Daten-Bus  
**+12:** 12 V Gleichstrom  
**C, NO, NC:** Relais-Kontakte (Verbindung Türöffner)  
**BS, -:** Drucktaste Flur  
**S:** Aktivierung des Umschalters.

Pag 9

K)

**E Conectores Placa:**

- Bornas de video, (coaxial).  
**V:** vivo  
**M:** malla  
**Ct:** activación telecamara (11 Vdc)
- Bornas de Conexión del sistema:  
**+, -:** alimentación (18 Vdc).  
**L:** bus de datos.  
**+12:** salida 12 Vdc (0,4 A. max).  
**C, NO, NC:** contactos relé  
(conexión abrepuertas)  
**BS, -:** pulsador zaguán.  
**S:** activación del cambiador

**EN Panel Connectors:**

- Video terminals (coaxial):  
**V:** live  
**M:** shield  
**Ct:** camera activation (11 Vdc)
- System connection terminals:  
**+, -:** power supply (18 Vdc).  
**+12:** 12 Vdc output.  
**L:** data bus.  
**C, NO, NC:** relay contacts (door-opener connection)  
**BS, -:** entrance hall button.  
**S:** activation of the exchanger

**F Connecteurs platine:**

- Bornes vidéo (câble coaxial).  
**V:** vif  
**M:** maille  
**Ct:** activation caméra (11 Vdc)
- Bornes de raccordement du système.  
**+, -:** alimentation (18 Vcc).  
**L:** bus de données.  
**+12:** 12 Vcc  
**C, NO (no), NC (nf):** contacts relais (connexion gâche électrique)  
**BS, -:** bouton-poussoir vestibule.  
**S:** activation de l'échangeur.

**D Anschlüsse Türstation:**

- Video-Klemmen (Koaxial)  
**V:** Kern  
**M:** Schirm  
**Ct:** Aktivierung der Kamera (11 VDC)
- Anschlussklemmen des Systems:  
**+, -:** Stromversorgung (18 VDC)  
**L:** Daten-Bus  
**+12:** 12 V Gleichstrom  
**C, NO, NC:** Relais-Kontakte (Verbindung Türöffner)  
**BS, -:** Drucktaste Flur  
**S:** Aktivierung des Umschalters.

Pag 9

**P Conectores de Placa:**

- Terminais de vídeo (coaxial).  
**V:** vivo  
**M:** malha  
**Ct:** activação telecâmara (11 Vdc)
- Terminais de ligação do sistema:  
**+, -:** alimentação (18 Vdc).  
**L:** bus de dados.  
**+12:** 12 Vdc  
**C, NA, NC:** contactos de relé  
 (ligação do trinco)  
**BS, -:** botão para abrir a porta do vestíbulo.  
**S:** activação do comutador

**L)**

- E CN3:** Conexión leds de estado. De gran utilidad para personas discapacitadas, permite conectar leds que informan del estado de la comunicación.  
 L2, L3, L4: entregan un negativo cuando se realiza la acción correspondiente, activando el led conectado entre "Lx" y "+":
- EN CN3:** Connection Status Leds Very useful for disabled people, allowing leds to be connected which provide information on communication status.  
 L2, L3, L4: generates a negative signal when the corresponding action is taken, activating the led connected between "Lx" and "+":
- F CN3 :** connexion DEL d'état. Très utile pour les personnes handicapées, il permet de raccorder des DEL indiquant l'état de la communication.  
 L2, L3, L4 : transmettent un négatif lorsque l'action correspondante est effectuée, en activant la DEL raccordée entre « Lx » et « + ».
- D CN3:** Anschluss LED-Statusanzeige Von großem Nutzen für behinderte Personen; ermöglicht das Anschließen von LEDs, die über den Zustand der Verbindung informieren.  
 L2, L3, L4: übermitteln einen Negativstrom, wenn der entsprechende Vorgang ausgelöst wird, worauf die angeschlossene LED zwischen "Lx" und "+" aktiviert wird:

**P Conectores de Placa:**

- Terminais de vídeo (coaxial).  
**V:** vivo  
**M:** malha  
**Ct:** activação telecâmara (11 Vdc)
- Terminais de ligação do sistema:  
**+, -:** alimentação (18 Vdc).  
**L:** bus de dados.  
**+12:** 12 Vdc  
**C, NA, NC:** contactos de relé  
 (ligação do trinco)  
**BS, -:** botão para abrir a porta do vestíbulo.  
**S:** activação do comutador

**L)**

- E CN3:** Conexión leds de estado. De gran utilidad para personas discapacitadas, permite conectar leds que informan del estado de la comunicación.  
 L2, L3, L4: entregan un negativo cuando se realiza la acción correspondiente, activando el led conectado entre "Lx" y "+":
- EN CN3:** Connection Status Leds Very useful for disabled people, allowing leds to be connected which provide information on communication status.  
 L2, L3, L4: generates a negative signal when the corresponding action is taken, activating the led connected between "Lx" and "+":
- F CN3 :** connexion DEL d'état. Très utile pour les personnes handicapées, il permet de raccorder des DEL indiquant l'état de la communication.  
 L2, L3, L4 : transmettent un négatif lorsque l'action correspondante est effectuée, en activant la DEL raccordée entre « Lx » et « + ».
- D CN3:** Anschluss LED-Statusanzeige Von großem Nutzen für behinderte Personen; ermöglicht das Anschließen von LEDs, die über den Zustand der Verbindung informieren.  
 L2, L3, L4: übermitteln einen Negativstrom, wenn der entsprechende Vorgang ausgelöst wird, worauf die angeschlossene LED zwischen "Lx" und "+" aktiviert wird:

**Ⓟ CN3:** Ligação dos LEDS de estado. De grande utilidade para pessoas deficientes, permite deficientes que informam do estado da comunicação.

L2, L3, L4: entregam um negativo quando se realiza a acção correspondente, activando o led ligado entre «Lx» y «+»:

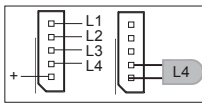

L2	L3	L4
Led de llamada	Led de comunicaci3n	Led apertura de puerta
Call Led	Communication Led	Lock Release Led
DEL d'appel	DEL de communication	DEL ouverture des portes
LED Anruf	LED Sprechverbindung	LED T3r3ffnung
LED de chamada	LED de comunicac3o	LED abertura de porta
Led di chiamata	Led di comunicazione	Led di apertura porta

M)

- ⓔ Versi3n del amplificador
- ⓓ Amplifier version
- ⓕ Version de l'amplificateur
- Ⓛ Lautsprecherversion
- Ⓟ Vers3o do amplificador

**Ⓟ CN3:** Ligação dos LEDS de estado. De grande utilidade para pessoas deficientes, permite deficientes que informam do estado da comunicaç3o.

L2, L3, L4: entregam um negativo quando se realiza a acç3o correspondente, activando o led ligado entre «Lx» y «+»:

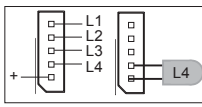

L2	L3	L4
Led de llamada	Led de comunicaci3n	Led apertura de puerta
Call Led	Communication Led	Lock Release Led
DEL d'appel	DEL de communication	DEL ouverture des portes
LED Anruf	LED Sprechverbindung	LED T3r3ffnung
LED de chamada	LED de comunicac3o	LED abertura de porta
Led di chiamata	Led di comunicazione	Led di apertura porta

M)

- ⓔ Versi3n del amplificador
- ⓓ Amplifier version
- ⓕ Version de l'amplificateur
- Ⓛ Lautsprecherversion
- Ⓟ Vers3o do amplificador

**Ⓜ RESTAURAR A VALORES DE FÁBRICA: Reset**

El amplificador VDS dispone de la función de «Reset» que permite restaurar los parámetros programados (tiempo apertura de puerta y zaguán, códigos de acceso, mapeado) a valores de fábrica.

**RESET Mapeado**

- 1º. Resetear el amplificador: quitar alimentación.
- 2º. Con el botón SW1 pulsado, dar alimentación y mantener pulsado el botón SW1 hasta escuchar un sonido de confirmación de reset.

**RESET desde placas de teclado**

Los pasos a realizar para restaurar los valores de fábrica son los siguientes:

- 1º. Resetear el amplificador: quitar alimentación.
- 2º. Dar alimentación, y en los primeros 60 segundos teclear el código **A708B9**. Tras esta pulsación sonará un pitido largo, confirmado la restauración de los valores de fábrica.

**Ⓜ RESTORE DEFAULT VALUES: RESET**

The VDS amplifier has a 'Reset' function which can be used to restore programmed default parameters (door and hall lock-release time, access cods, mapping).

**Mapping RESET**

- 1.- Reset amplifier: disconnect power supply
- 2.- Press the SW1 button, connect power supply and keep SW1 button pressed until you hear the reset confirmation sound.

**RESET from keypad panels**

To restore the default values, follow the steps below:

- 1.- Reset amplifier: disconnect power supply
- 2.- Connect power supply and within the first 60 seconds, enter the code **A708B9**. After entering the code, a prolonged beep will sound to confirm the restoration of default values.

**Ⓜ RESTAURAR A VALORES DE FÁBRICA: Reset**

El amplificador VDS dispone de la función de «Reset» que permite restaurar los parámetros programados (tiempo apertura de puerta y zaguán, códigos de acceso, mapeado) a valores de fábrica.

**RESET Mapeado**

- 1º. Resetear el amplificador: quitar alimentación.
- 2º. Con el botón SW1 pulsado, dar alimentación y mantener pulsado el botón SW1 hasta escuchar un sonido de confirmación de reset.

**RESET desde placas de teclado**

Los pasos a realizar para restaurar los valores de fábrica son los siguientes:

- 1º. Resetear el amplificador: quitar alimentación.
- 2º. Dar alimentación, y en los primeros 60 segundos teclear el código **A708B9**. Tras esta pulsación sonará un pitido largo, confirmado la restauración de los valores de fábrica.

**Ⓜ RESTORE DEFAULT VALUES: RESET**

The VDS amplifier has a 'Reset' function which can be used to restore programmed default parameters (door and hall lock-release time, access cods, mapping).

**Mapping RESET**

- 1.- Reset amplifier: disconnect power supply
- 2.- Press the SW1 button, connect power supply and keep SW1 button pressed until you hear the reset confirmation sound.

**RESET from keypad panels**

To restore the default values, follow the steps below:

- 1.- Reset amplifier: disconnect power supply
- 2.- Connect power supply and within the first 60 seconds, enter the code **A708B9**. After entering the code, a prolonged beep will sound to confirm the restoration of default values.



**① RÉCUPÉRATION AUX VALEURS PAR DÉFAUT : REMISE À ZÉRO**

L'amplificateur VDS dispose de la fonction « Remise à zéro » qui permet de rétablir les paramètres programmés (durée d'ouverture des portes et hall, codes d'accès, mappage) sur les valeurs par défaut.

**RESET Mappage**

- 1°- Remettre à zéro l'amplificateur : Couper l'alimentation.
- 2°- En maintenant le bouton SW1 enfoncé, alimenter le dispositif jusqu'à ce qu'un avertissement sonore de confirmation de la remise à zéro soit émis.

**REMISE À ZÉRO à partir des platines à clavier**

Les étapes à effectuer pour récupérer les valeurs par défaut sont les suivantes :

- 1°- Remettre à zéro l'amplificateur : Couper l'alimentation.
- 2°- Au cours des 60 premières secondes, composer le code **A708B9**. A la suite de cette saisie, un long bip sera émis ; il confirmera la récupération des valeurs par défaut.

**② WIEDERHERSTELLUNG DER WERKSSEITIGEN PARAMETER: NULLSTELLUNG**

Der VDS-Verstärker verfügt über eine Reset-Funktion, die es ermöglicht die werksseitig programmierten Parameter wieder herzustellen (Türöffnungszeit und Treppenhausbeleuchtung, Zutrittskodes, Mapping).

**Mapping NULLSTELLUNG**

1. Nullstellung des Verstärkers: Stromversorgung unterbrechen.
2. SW1-Taste gedrückt halten, Stromzufuhr wiederherstellen ohne die SW1-Taste los zulassen bis ein Piepton die Nullstellung bestätigt.

**NULLSTELLUNG über Türstationen mit Tastatur**

Schritte, zur Wiederherstellung der werksseitig einprogrammierten Parameter:

1. Nullstellung des Verstärkers: Stromversorgung unterbrechen.
2. Nullstellung des Verstärkers: Stromversorgung wiederherstellen und innerhalb von 60 Sekunden den Code **A708B9** eingeben. Nach der Kodeeingabe ertönt ein langer Piepton zur Bestätigung der Wiederherstellung der werksseitig einprogrammierten Werte.

Pag 13

**① RÉCUPÉRATION AUX VALEURS PAR DÉFAUT : REMISE À ZÉRO**

L'amplificateur VDS dispose de la fonction « Remise à zéro » qui permet de rétablir les paramètres programmés (durée d'ouverture des portes et hall, codes d'accès, mappage) sur les valeurs par défaut.

**RESET Mappage**

- 1°- Remettre à zéro l'amplificateur : Couper l'alimentation.
- 2°- En maintenant le bouton SW1 enfoncé, alimenter le dispositif jusqu'à ce qu'un avertissement sonore de confirmation de la remise à zéro soit émis.

**REMISE À ZÉRO à partir des platines à clavier**

Les étapes à effectuer pour récupérer les valeurs par défaut sont les suivantes :

- 1°- Remettre à zéro l'amplificateur : Couper l'alimentation.
- 2°- Au cours des 60 premières secondes, composer le code **A708B9**. A la suite de cette saisie, un long bip sera émis ; il confirmera la récupération des valeurs par défaut.

**② WIEDERHERSTELLUNG DER WERKSSEITIGEN PARAMETER: NULLSTELLUNG**

Der VDS-Verstärker verfügt über eine Reset-Funktion, die es ermöglicht die werksseitig programmierten Parameter wieder herzustellen (Türöffnungszeit und Treppenhausbeleuchtung, Zutrittskodes, Mapping).

**Mapping NULLSTELLUNG**

1. Nullstellung des Verstärkers: Stromversorgung unterbrechen.
2. SW1-Taste gedrückt halten, Stromzufuhr wiederherstellen ohne die SW1-Taste los zulassen bis ein Piepton die Nullstellung bestätigt.

**NULLSTELLUNG über Türstationen mit Tastatur**

Schritte, zur Wiederherstellung der werksseitig einprogrammierten Parameter:

1. Nullstellung des Verstärkers: Stromversorgung unterbrechen.
2. Nullstellung des Verstärkers: Stromversorgung wiederherstellen und innerhalb von 60 Sekunden den Code **A708B9** eingeben. Nach der Kodeeingabe ertönt ein langer Piepton zur Bestätigung der Wiederherstellung der werksseitig einprogrammierten Werte.

Pag 13

**Ⓟ RESTAURAR PARA VALORES DE FÁBRICA: RESET**

O amplificador VDS dispõe da função de «Reset», que permite restaurar os parâmetros programados (tempo de abertura da puerta e vestibulo, códigos de acesso, mapeamento) para os valores de fábrica.

**RESET Mapeamento**

1º- Restaurar o amplificador: cortar a alimentação.

2º- Com o botão SW1 pressionado, ligar a alimentação e manter o botão SW1 pressionado até se ouvir um som de confirmação de reset

**RESET a partir placas com teclado**

Os passos a realizar para restaurar os valores de fábrica são os seguintes:

1º- Restaurar o amplificador: cortar a alimentação.

2º- Fornecer alimentação e, nos primeiros 60 segundos, digitar o código **A708B9**. Após esta operação, ouve-se um silvo longo, confirmando a restauração dos valores de fábrica.

**Ⓟ RESTAURAR PARA VALORES DE FÁBRICA: RESET**

O amplificador VDS dispõe da função de «Reset», que permite restaurar os parâmetros programados (tempo de abertura da puerta e vestibulo, códigos de acesso, mapeamento) para os valores de fábrica.

**RESET Mapeamento**

1º- Restaurar o amplificador: cortar a alimentação.

2º- Com o botão SW1 pressionado, ligar a alimentação e manter o botão SW1 pressionado até se ouvir um som de confirmação de reset

**RESET a partir placas com teclado**

Os passos a realizar para restaurar os valores de fábrica são os seguintes:

1º- Restaurar o amplificador: cortar a alimentação.

2º- Fornecer alimentação e, nos primeiros 60 segundos, digitar o código **A708B9**. Após esta operação, ouve-se um silvo longo, confirmando a restauração dos valores de fábrica.

- E** PRECABLEADO   
 **EN** INTERNAL WIRING   
 **F** PRECÂBLAGE   
 **D** VERKABELUNG  
**P** PRE-CABLAGEM

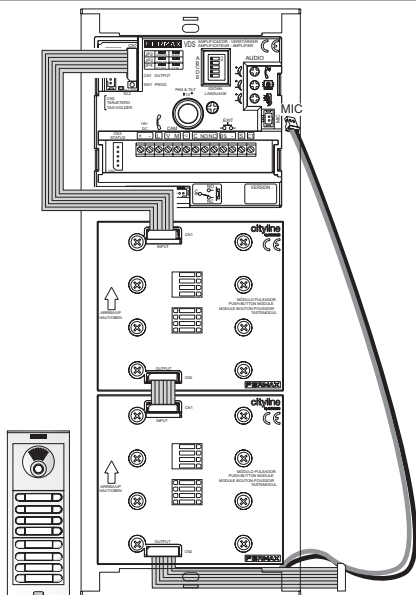

- E** Los Pulsadores de la Placas Modulares, no requieren módulo de extensión de llamadas.  
**EN** The modular panel buttons do not require call extension modules.  
**F** Les Boutons-poussoirs des Platines Modulaires n'ont pas besoin de module d'extension d'appels.  
**D** Die Tasten der modularen Türstationen benötigen kein Ruferweiterungsmodul.  
**P** Os Botões das Placas Modulares não requerem módulo de extensão de chamadas.

- E** PRECABLEADO   
 **EN** INTERNAL WIRING   
 **F** PRECÂBLAGE   
 **D** VERKABELUNG  
**P** PRE-CABLAGEM

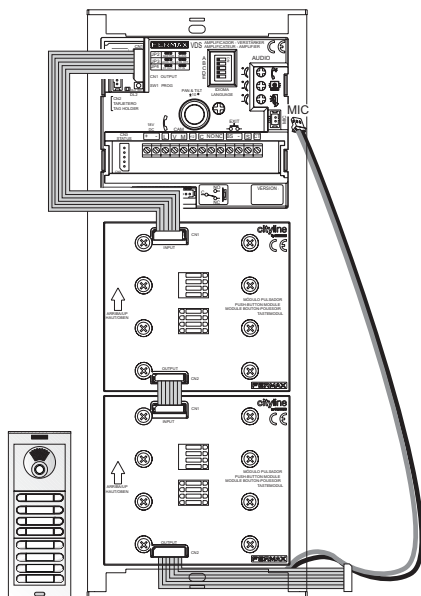

- E** Los Pulsadores de la Placas Modulares, no requieren módulo de extensión de llamadas.  
**EN** The modular panel buttons do not require call extension modules.  
**F** Les Boutons-poussoirs des Platines Modulaires n'ont pas besoin de module d'extension d'appels.  
**D** Die Tasten der modularen Türstationen benötigen kein Ruferweiterungsmodul.  
**P** Os Botões das Placas Modulares não requerem módulo de extensão de chamadas.

- E** CARACTERÍSTICAS TÉCNICAS      **EN** TECHNICAL FEATURES  
**F** CARACTERISTIQUES TECHNIQUES      **D** TECHNISCHE EIGENSCHAFTEN  
**P** CARACTERÍSTICAS TÉCNICAS

	Alimentación - <i>Power Supply</i> - Alimentation <i>Stromversorgung</i> - Alimentação	18 Vdc
	Consumo - Consumption - Consommation <i>Stromverbrauch</i> - Consumo	
	en reposo - <i>in standby</i> - au repos - <i>Im Bereitschaftsmodus</i> - em repouso	57 mA
	audio activo - audio active - avec audio - Audioverbindung - áudio activo	210 mA
	cámara - camera - caméra - Kamera - câmara	180 mA
<b>IP43 / IK07</b>	iluminación - lighting - éclairage - Beleuchtung - iluminação	35 mA
Potencia audio sentido vivienda-calle - <i>Audio power from the apartment to the panel</i> Puissance de l'audio sens poste-platine - <i>Audio-Leistung in Richtung Türstation</i> Potência áudio sentido rua		1 W
Potencia audio sentido calle-vivienda - <i>Audio power from the panel to the apartment</i> Puissance de l'audio sens platine-poste - <i>Audio-Leistung in Richtung Telefon</i> Potência áudio sentido telefone		0,15 W
Temperatura de funcionamiento - <i>Operating Temperature</i> Température de fonctionnement - <i>Betriebstemperatur</i> Temperatura de funcionamento		[-10 , +60 °C] [14, 140°F]
Volumen regulable en ambos sentidos - <i>Adjustable volume both ways</i> Volume réglable dans les deux sens - <i>Regulierbare Lautstärke in beiden Richtungen</i> Volume regulável em ambos os sentidos		

- E** CARACTERÍSTICAS TÉCNICAS      **EN** TECHNICAL FEATURES  
**F** CARACTERISTIQUES TECHNIQUES      **D** TECHNISCHE EIGENSCHAFTEN  
**P** CARACTERÍSTICAS TÉCNICAS

	Alimentación - <i>Power Supply</i> - Alimentation <i>Stromversorgung</i> - Alimentação	18 Vdc
	Consumo - Consumption - Consommation <i>Stromverbrauch</i> - Consumo	
	en reposo - <i>in standby</i> - au repos - <i>Im Bereitschaftsmodus</i> - em repouso	57 mA
	audio activo - audio active - avec audio - Audioverbindung - áudio activo	210 mA
	cámara - camera - caméra - Kamera - câmara	180 mA
<b>IP43 / IK07</b>	iluminación - lighting - éclairage - Beleuchtung - iluminação	35 mA
Potencia audio sentido vivienda-calle - <i>Audio power from the apartment to the panel</i> Puissance de l'audio sens poste-platine - <i>Audio-Leistung in Richtung Türstation</i> Potência áudio sentido rua		1 W
Potencia audio sentido calle-vivienda - <i>Audio power from the panel to the apartment</i> Puissance de l'audio sens platine-poste - <i>Audio-Leistung in Richtung Telefon</i> Potência áudio sentido telefone		0,15 W
Temperatura de funcionamiento - <i>Operating Temperature</i> Température de fonctionnement - <i>Betriebstemperatur</i> Temperatura de funcionamento		[-10 , +60 °C] [14, 140°F]
Volumen regulable en ambos sentidos - <i>Adjustable volume both ways</i> Volume réglable dans les deux sens - <i>Regulierbare Lautstärke in beiden Richtungen</i> Volume regulável em ambos os sentidos		

<b><i>Esquemas de cableado</i></b>	<b>E</b>
<b><i>Wiring diagrams</i></b>	<b>EN</b>
<b><i>Schémas de câblage</i></b>	<b>F</b>
<b><i>Verkabelungsschema</i></b>	<b>D</b>
<b><i>Esquemas do cableado</i></b>	<b>P</b>

<b><i>Esquemas de cableado</i></b>	<b>E</b>
<b><i>Wiring diagrams</i></b>	<b>EN</b>
<b><i>Schémas de câblage</i></b>	<b>F</b>
<b><i>Verkabelungsschema</i></b>	<b>D</b>
<b><i>Esquemas do cableado</i></b>	<b>P</b>

AUDIO

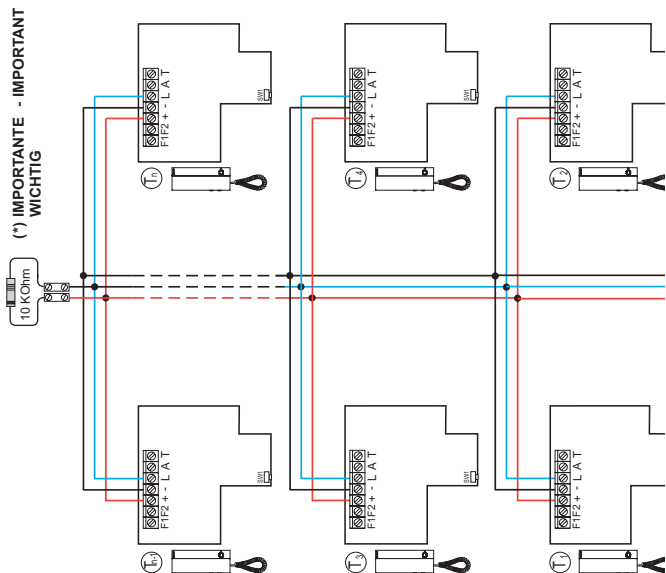

AUDIO

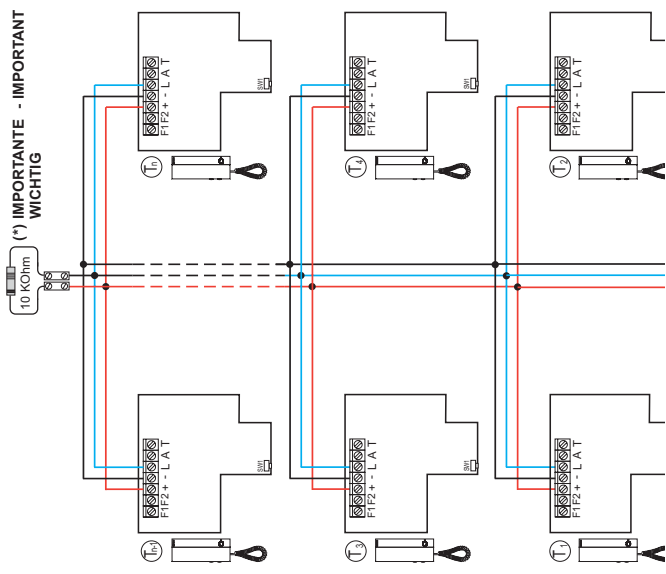



VIDEO (con coaxial / with coaxial / avec coaxial /

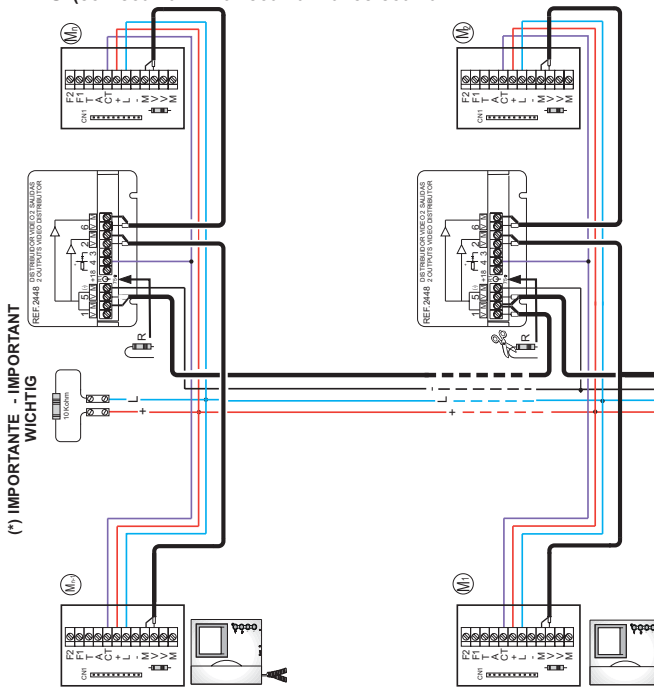

VIDEO (con coaxial / with coaxial / avec coaxial /

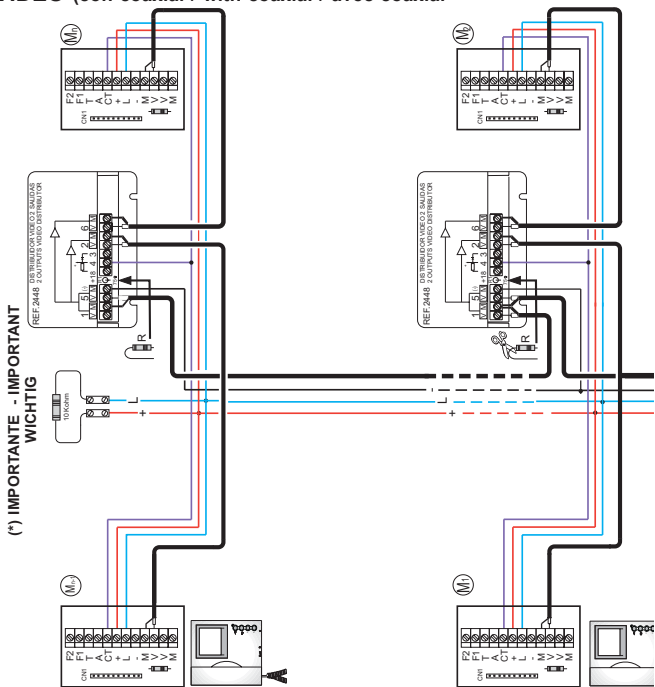



mit Koaxial / com coaxial)

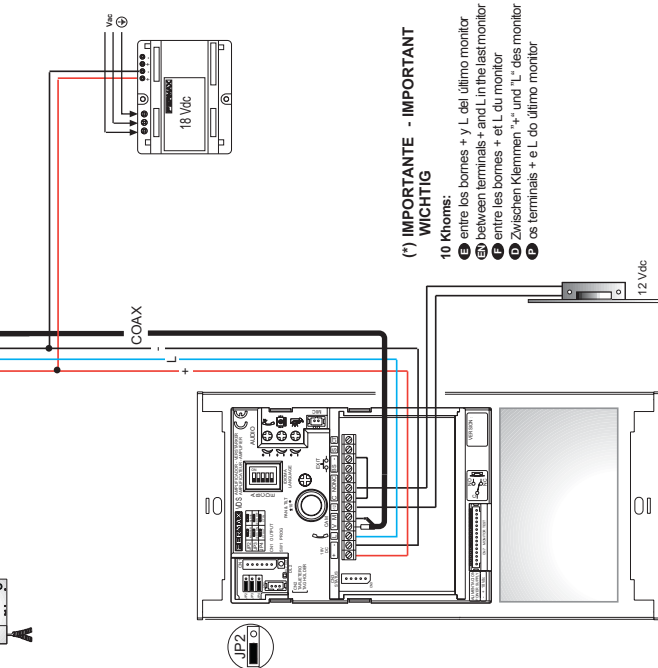

(\*) **IMPORTANTE - IMPORTANT**  
**WICHTIG**

10 Khoms:

- E** entre los bornes + y L del último monitor
- EN** between terminals + and L in the last monitor
- F** entre les bornes + et L du monitor
- D** Zwischen Klemmen "+ und "L" des monitor
- P** os terminals + e L do último monitor

mit Koaxial / com coaxial)

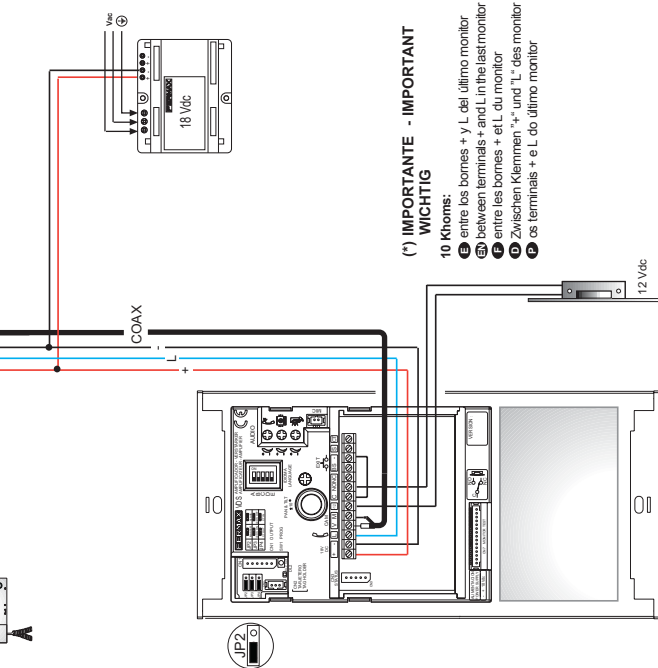

(\*) **IMPORTANTE - IMPORTANT**  
**WICHTIG**

10 Khoms:

- E** entre los bornes + y L del último monitor
- EN** between terminals + and L in the last monitor
- F** entre les bornes + et L du monitor
- D** Zwischen Klemmen "+ und "L" des monitor
- P** os terminals + e L do último monitor

VIDEO (5 hilos o UTP CAT5 / 5 wires or UTP CAT5 /

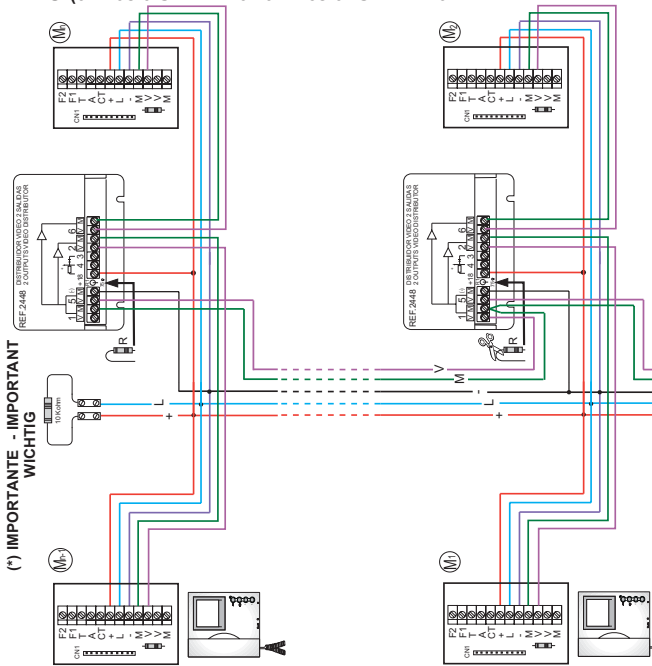

VIDEO (5 hilos o UTP CAT5 / 5 wires or UTP CAT5 /

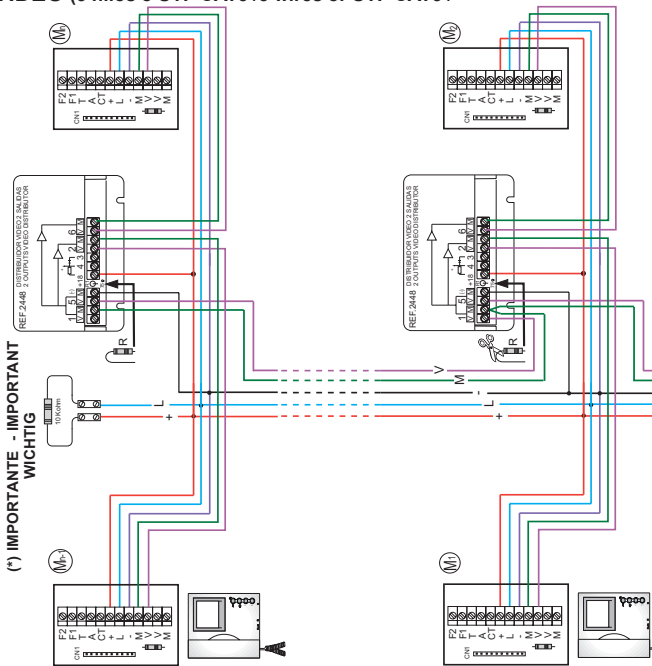

5 fils ou UTP CAT5 / 5 Drahnte oder UTP CAT5 / 5 fios ou UTP CAT5)

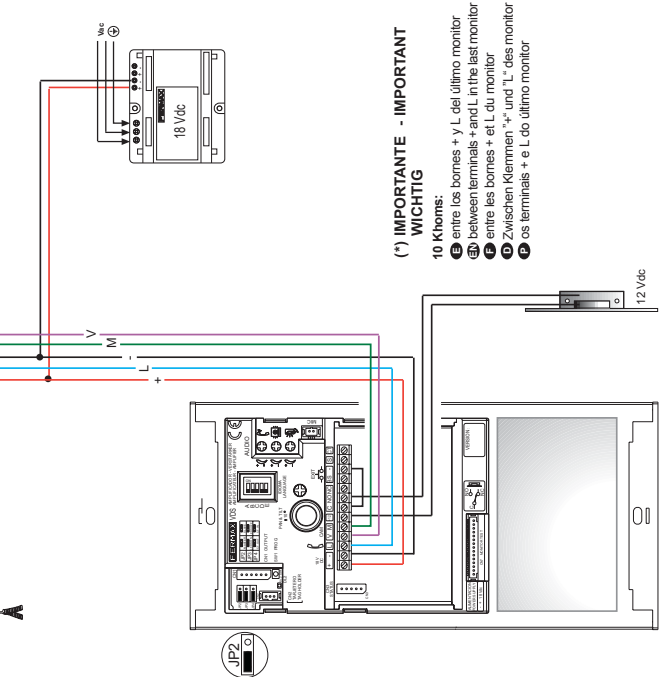

(\*) IMPORTANTE - IMPORTANT  
WICHTIG

10 Khoms:

- E** entre los bornes + y L. del ltimo monitor
- F** between terminals + and L. in the last monitor
- F** entre les bornes + et L. du monitor
- D** Zwischen Klemmen "+", "L" des monitor
- P** os terminals + e L. do ltimo monitor

5 fils ou UTP CAT5 / 5 Drahnte oder UTP CAT5 / 5 fios ou UTP CAT5)

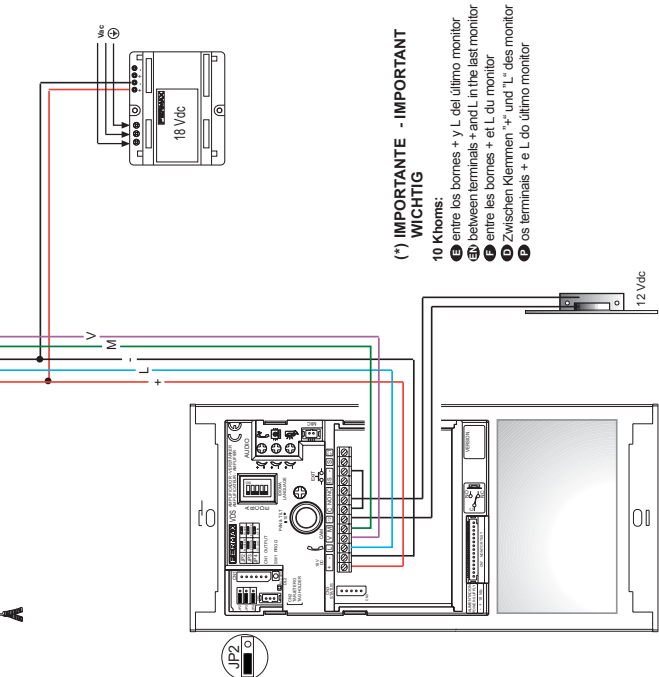

(\*) IMPORTANTE - IMPORTANT  
WICHTIG

10 Khoms:

- E** entre los bornes + y L. del ltimo monitor
- F** between terminals + and L. in the last monitor
- F** entre les bornes + et L. du monitor
- D** Zwischen Klemmen "+", "L" des monitor
- P** os terminals + e L. do ltimo monitor

- E** CONEXIÓN ABREPUERTAS
- F** RACCORDEMENT GÂCHE
- P** LIGAÇÃO DO TRINCO

- EN** DOOR LOCK-RELEASE CONNECTION
- EO** ANSCHLUSS TÜRÖFFNER

**12 Vac**

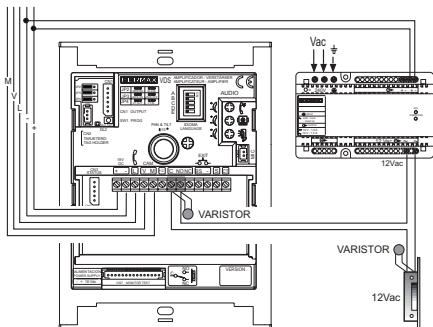

**12 Vdc**

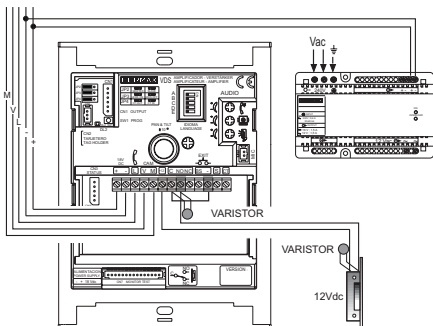

- E** CONEXIÓN ABREPUERTAS
- F** RACCORDEMENT GÂCHE
- P** LIGAÇÃO DO TRINCO

- EN** DOOR LOCK-RELEASE CONNECTION
- EO** ANSCHLUSS TÜRÖFFNER

**12 Vac**

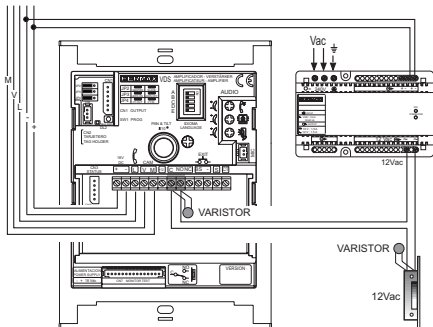

**12 Vdc**

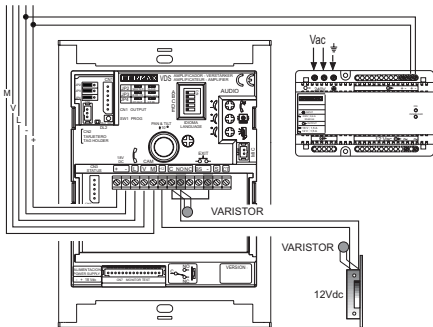

- Ⓔ TABLAS SECCIONES DISTANCIAS      Ⓔ TABLES SECTIONS DISTANCES
- Ⓟ TABELAS DE SECÇÕES E DISTÂNCIAS      Ⓟ TABLEAUX SECTIONS DISTANCES
- Ⓣ TABELLE MIT DEN QUERSCHNITTEN UND DISTANZEN

- Ⓔ *Instalaciones: AUDIO*
- Ⓔ *Systems: AUDIO*
- Ⓟ *Installations : AUDIO*
- Ⓣ *Anlagen: AUDIO*
- Ⓟ *Instalações: ÁUDIO*

metros / metres	pies / feet	mm <sup>2</sup>
1 - 50	3 - 150	1 mm <sup>2</sup>
50 - 100	150 - 300	1,5 mm <sup>2</sup>
100 - 200	300 - 600	2,5 mm <sup>2</sup>

- Ⓔ *Instalaciones: VIDEO con COAXIAL*
- Ⓔ *Systems: VIDEO with COAXIAL*
- Ⓟ *Installations : VIDÉO avec COAXIAL*
- Ⓣ *Anlagen: VIDEO mit KOAXIAL*
- Ⓟ *Instalações: VÍDEO com COAXIAL*

metros / metres	pies / feet	mm <sup>2</sup>	AWG	Impedance
1 - 50	3 - 150	1 mm <sup>2</sup>	17	75 Ohm
50 - 100	150 - 300	1,5 mm <sup>2</sup>	15	75 Ohm
100 - 200	300 - 600	2,5 mm <sup>2</sup>	13	75 Ohm

- Ⓔ *Instalaciones: 5 hilos o UTP CAT5*
- Ⓔ *Systems: 5 wires or UTP CAT5*
- Ⓟ *Installations : 5 fils ou UPT CAT5*
- Ⓣ *Anlagen: 5 Drähte oder UTP CAT5*
- Ⓟ *Instalações: 5 fios ou UTP CAT5*

metros / metres	pies / feet	mm <sup>2</sup>	AWG	UTP CAT5
1 - 50	3 - 150	1 mm <sup>2</sup>	17	UTP CAT5
50 - 100	150 - 300	1,5 mm <sup>2</sup>	15	
100 - 200	300 - 600	2,5 mm <sup>2</sup>	13	

- Ⓔ TABLAS SECCIONES DISTANCIAS      Ⓔ TABLES SECTIONS DISTANCES
- Ⓟ TABELAS DE SECÇÕES E DISTÂNCIAS      Ⓟ TABLEAUX SECTIONS DISTANCES
- Ⓣ TABELLE MIT DEN QUERSCHNITTEN UND DISTANZEN

- Ⓔ *Instalaciones: AUDIO*
- Ⓔ *Systems: AUDIO*
- Ⓟ *Installations : AUDIO*
- Ⓣ *Anlagen: AUDIO*
- Ⓟ *Instalações: ÁUDIO*

metros / metres	pies / feet	mm <sup>2</sup>
1 - 50	3 - 150	1 mm <sup>2</sup>
50 - 100	150 - 300	1,5 mm <sup>2</sup>
100 - 200	300 - 600	2,5 mm <sup>2</sup>

- Ⓔ *Instalaciones: VIDEO con COAXIAL*
- Ⓔ *Systems: VIDEO with COAXIAL*
- Ⓟ *Installations : VIDÉO avec COAXIAL*
- Ⓣ *Anlagen: VIDEO mit KOAXIAL*
- Ⓟ *Instalações: VÍDEO com COAXIAL*

































metros / metres	pies / feet	mm <sup>2</sup>	AWG	Impedance
1 - 50	3 - 150	1 mm <sup>2</sup>	17	75 Ohm
50 - 100	150 - 300	1,5 mm <sup>2</sup>	15	75 Ohm
100 - 200	300 - 600	2,5 mm <sup>2</sup>	13	75 Ohm

- Ⓔ *Instalaciones: 5 hilos o UTP CAT5*
- Ⓔ *Systems: 5 wires or UTP CAT5*
- Ⓟ *Installations : 5 fils ou UPT CAT5*
- Ⓣ *Anlagen: 5 Drähte oder UTP CAT5*
- Ⓟ *Instalações: 5 fios ou UTP CAT5*

metros / metres	pies / feet	mm <sup>2</sup>	AWG	UTP CAT5
1 - 50	3 - 150	1 mm <sup>2</sup>	17	UTP CAT5
50 - 100	150 - 300	1,5 mm <sup>2</sup>	15	
100 - 200	300 - 600	2,5 mm <sup>2</sup>	13	

































**SINTETIZADOR DE VOZ  
VOICE SYNTHESIZER  
SYNTHETISEUR VOCAL  
SPRACHSYNTHESIZER**

 **CODIFICACIÓN IDIOMAS (Ver tabla)**  
**LANGUAGE CODING (see table)**  
**CODIFICATION LANGUES (voir tableau)**  
**SPRACHKODIERUNG (siehe Tabelle)**

 0	 1	 2	 3	 4	 5	 6	 7
 8	 9	 10	 11	 12	 13	 14	 15
 16	 17	 18	 19	 20	 21	 22	 23
 24	 25	 26	 27	 28	 29	 30	 31

**SINTETIZADOR DE VOZ  
VOICE SYNTHESIZER  
SYNTHETISEUR VOCAL  
SPRACHSYNTHESIZER**

 **CODIFICACIÓN IDIOMAS (Ver tabla)**  
**LANGUAGE CODING (see table)**  
**CODIFICATION LANGUES (voir tableau)**  
**SPRACHKODIERUNG (siehe Tabelle)**

 0	 1	 2	 3	 4	 5	 6	 7
 8	 9	 10	 11	 12	 13	 14	 15
 16	 17	 18	 19	 20	 21	 22	 23
 24	 25	 26	 27	 28	 29	 30	 31

CODE	ESPAÑOL	ENGLISH
0	castellano	Spanish
1	inglés	English
2	francés	French
3	holandés/flamenco	Dutch/Flemish
4	alemán	German
5	atalán	Catalan
6	valenciano	Valencian
7	balear	Balearic
8	portugués	Portuguese
9	euskera	Basque
10	gallego	Galician
11	griego	Greek
12	polaco	Polish
13	checo	Czech
14	eslovaco	Slovak
15	turco	Turkish

CODE	ESPAÑOL	ENGLISH
0	castellano	Spanish
1	inglés	English
2	francés	French
3	holandés/flamenco	Dutch/Flemish
4	alemán	German
5	atalán	Catalan
6	valenciano	Valencian
7	balear	Balearic
8	portugués	Portuguese
9	euskera	Basque
10	gallego	Galician
11	griego	Greek
12	polaco	Polish
13	checo	Czech
14	eslovaco	Slovak
15	turco	Turkish

CODE	ESPAÑOL	ENGLISH
16	chino	Chinese
17	persa/farsi	Persian/Farsi
18	árabe	Arabic
19	noruego	Norwegian
20	finés	Finnish
21	sueco	Swedish
22	danés	Danish
23	islandés	Icelandic
24	ruso	Russian
25	italiano	Italian
26	hindi	Hindi
27	húngaro	Hungarian
28	hebreo	Hebrew
29		
30	Campana	Bell
31	DESACTIVADO	DEACTIVATED

CODE	ESPAÑOL	ENGLISH
16	chino	Chinese
17	persa/farsi	Persian/Farsi
18	árabe	Arabic
19	noruego	Norwegian
20	finés	Finnish
21	sueco	Swedish
22	danés	Danish
23	islandés	Icelandic
24	ruso	Russian
25	italiano	Italian
26	hindi	Hindi
27	húngaro	Hungarian
28	hebreo	Hebrew
29		
30	Campana	Bell
31	DESACTIVADO	DEACTIVATED









**FERMAX**

**FERMAX**