

As a direct result of the overwhelming success of the 4000 Series, Videx have remodelled and improved the popular 800 Series and introduced, as its replacement the Videx 8000 Series.

The Videx 8000 range of modular push button panels allows the installer or end user to customise the appearance of the out door station in an easy and cost effective way dictated by the requirements of the installation.

The 8000 modules are assembled into supporting frames (which can be flush or surface mounting) and are available to house from 1 to 9 modules. Full electrical and mechanical compatibility has been retained, most of the 8000 Series modules have the same terminal configuration as the 800 Series and all modules in the 8000 range will fit the 800 series supporting frames.

The re-designed 8000 Series incorporates mechanical improvements for improved weather resistance and up-dating of the electronics for more reliable operation in harsher environmental conditions.

The remodelled 8000 Series front supports, rain-shields and surface mounting units are available in a range of finishes.



# 8000 series Modular System





Art.8881/A +  
Art.8837/A



Art.8881/BL +  
Art.8837/S

### 8000 SERIES FINISHES

Module finishes:

**A:** Aluminium

**S:** Stainless Steel

When ordering modules, suffix the product code with /A for aluminium or /S for stainless steel.

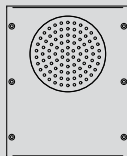

Art. 8835-0  
Art. 8837-0  
Art. 8837M-0  
Art. 8203-0

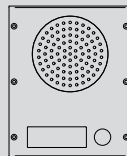

Art. 8835-1  
Art. 8837-1  
Art. 8837M-1  
Art. 8203M-1



Art. 8835-2  
Art. 8837-2  
Art. 8837M-2  
Art. 8203M-2

#### Art. "SPEAKER UNIT" FRONT PANEL MODULES FOR 1+1 INTERCOM SYSTEMS

**8835-0** 0 Call push buttons.

**8835-1** 1 Call push buttons.

**8835-2** 2 Call push buttons.

#### Art. "SPEAKER UNIT" FRONT PANEL MODULES FOR 4+1 INTERCOM SYSTEMS

**8837-0** 0 Call push buttons.

**8837-1** 1 Call push buttons.

**8837-2** 2 Call push buttons.

#### Art. "SPEAKER UNIT" FRONT PANEL MODULES FOR 3+1 INTERCOM SYSTEMS WITH ELECTRONIC CALL TONE

**8837M-0** 0 Call push buttons.

**8837M-1** 1 Call push buttons.

**8837M-2** 2 Call push buttons.

#### Art. 8000 SERIES "SPEAKER UNIT" FOR VX 2200 DIGITAL SYSTEM

**8203-0** 0 Call push buttons.

**8203-1** 1 Call push buttons.

**8203-2** 2 Call push buttons.

# 8000 series

## Modular System

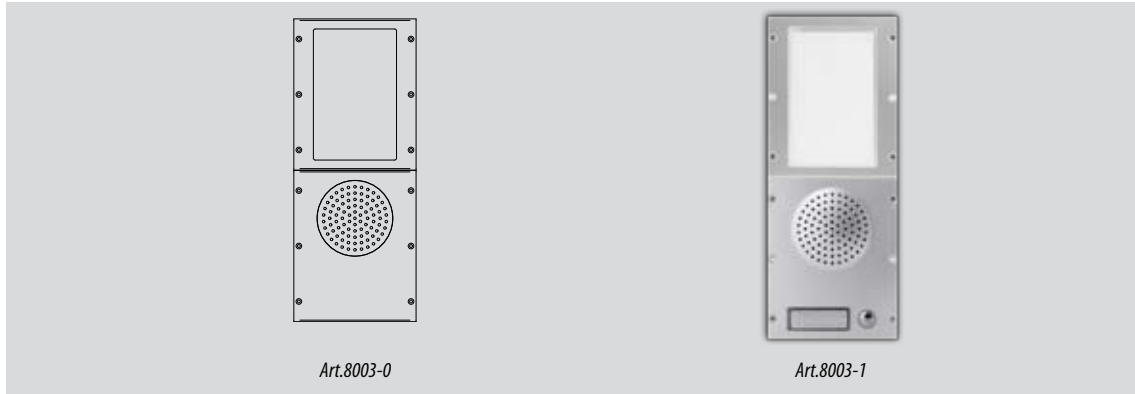

**Art. 8000 SERIES "SPEAKER UNIT" FOR VX 2000 DIGITAL SYSTEM**

**8003-0** 0 Call push buttons.

**8003-1** 1 Call push buttons.

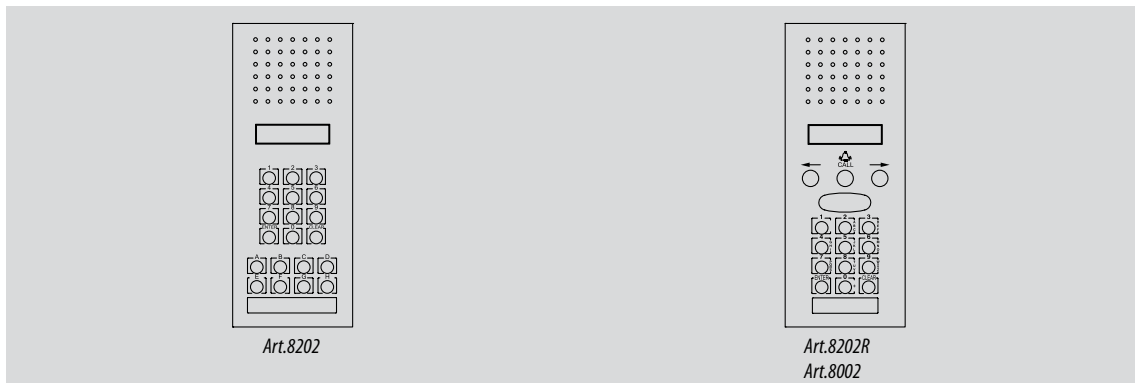

**Art. 8000 SERIES DIGITAL PANELS FOR VX 2000 DIGITAL SYSTEM**

**8002** Digital call panel with built in speaker unit, 2 x 16 character LCD display, keypad illumination, 12 button digital keypad with "Enter" and "Clear" buttons and 3 buttons for repertory name search.

**Art. 8000 SERIES DIGITAL PANELS FOR VX 2200 DIGITAL SYSTEM**

**8202** Digital call panel with built in speaker unit, 2 x 16 character LCD display, keypad illumination, 18 button digital keypad of which 10 are numeric and 8 alpha buttons (A..H) with "Enter" and "Clear" buttons.

**8202R** Digital call panel with built in speaker unit, 2 x 16 character LCD display, keypad illumination, 12 button digital keypad with "Enter" and "Clear" buttons and 3 buttons for repertory name search.

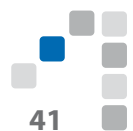

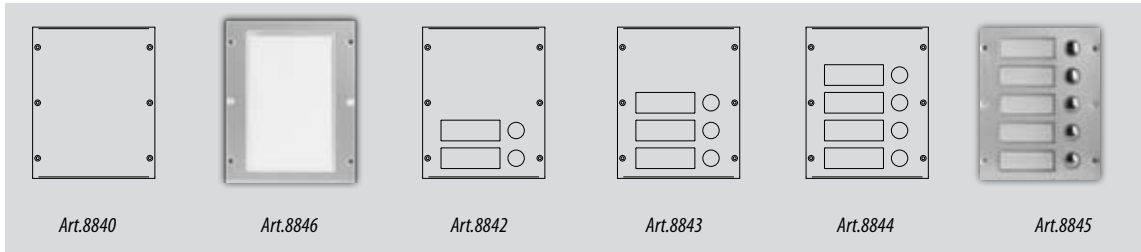

**Art. BLANK, INFORMATION AND BUTTON EXPANSION MODULES**

- 8840** Blanking module.
- 8846** Information module.
- 8842** 2 Call push buttons
- 8843** 3 Call push buttons.
- 8844** 4 Call push buttons.
- 8845** 5 Call push buttons.



**CAMERA MODULES**

Camera modules from 8000 series have a built in adjustable (13 degree in any direction) CCD autofocus camera with illumination LEDs, include the anti-mist system (requires an additional 13Vac/dc power source) and may be set up to work with coaxial or balanced video signal according to the system requirements. Required power supply 12/24Vdc.

**Art. CAMERA MODULES**

- 8830** Black and white camera module comprised of infrared illumination LEDs
- 8830C** Colour camera module comprised of white light illumination LEDs

# 8000 series

## Modular System



### ACCESS CONTROL MODULES

Videx produce a wide range of digital codelocks for "access control" systems among which there is a modular version of the 8800 and 8900. The codelocks use the latest microprocessor based PCB, which (when combined behind its tough stainless steel keypad) gives trouble free controlled access. The unit is easy to install and extremely robust at a low cost. It can be used as a stand alone keypad or combined with other 8000 series audio and video modules.



### Art. CODELOCKS MODULES

**8800** Codelock module, 2 codes/2 relay outputs.

**8900** Codelock module, 100 codes/2 relay outputs.

### Art. "READER" MODULES FOR CODED KEYS

**8849** Videx proximity coded-key readers are available in a "8000 Series" module. The device includes the reader circuit (with a reading range between 20 and 50mm depending on the key type used). A tri state LED and Buzzer is an intricate feature to indicate if a key has been accepted or denied. Connection between the "VproX" reader and the Control Unit requires a minimum of 5 wires over a maximum distance of 200mts. This unit combines a polycarbonate reader window with a stainless steel or aluminium frame.





### FRONT SUPPORTS, RAINSHIELDS, SURFACE MOUNTING UNITS

The "8000 Series" modules are available in both flush and surface mounting units. The flush mounting units combine with rain shields to cover any cutouts in the wall. Surface mounting units, flush mounting units and rain shields are available in the following finishes.

**A** Aluminium.

**BL** Black

When ordering, suffix the product code with /A for aluminium or /BL for black.

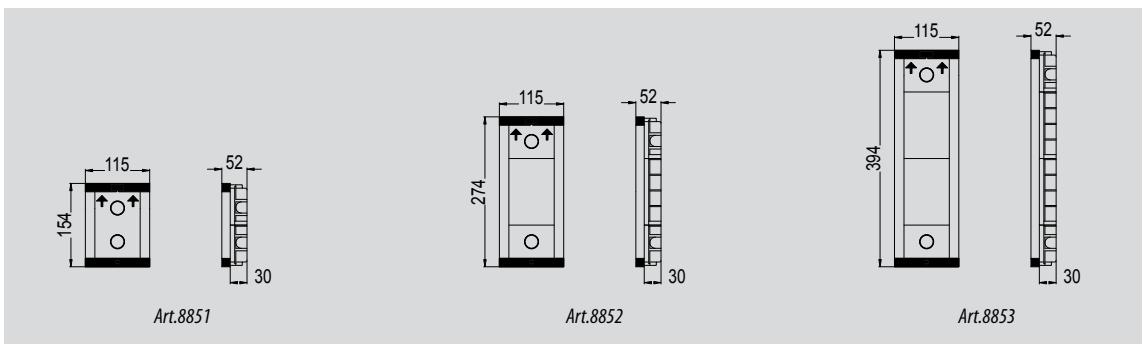

### FRONT SUPPORT

For flush mounted modules complete with stainless steel hinge and back box. width 115 mm., recessed depth 30 mm.

Art.	MODULES	FRONT FRAME(mm)	BACK BOX (mm)
8851	1	115x154x22	109x144x30
8852	2	115x274x22	109x265x30
8853	3	115x394x22	109x385x30



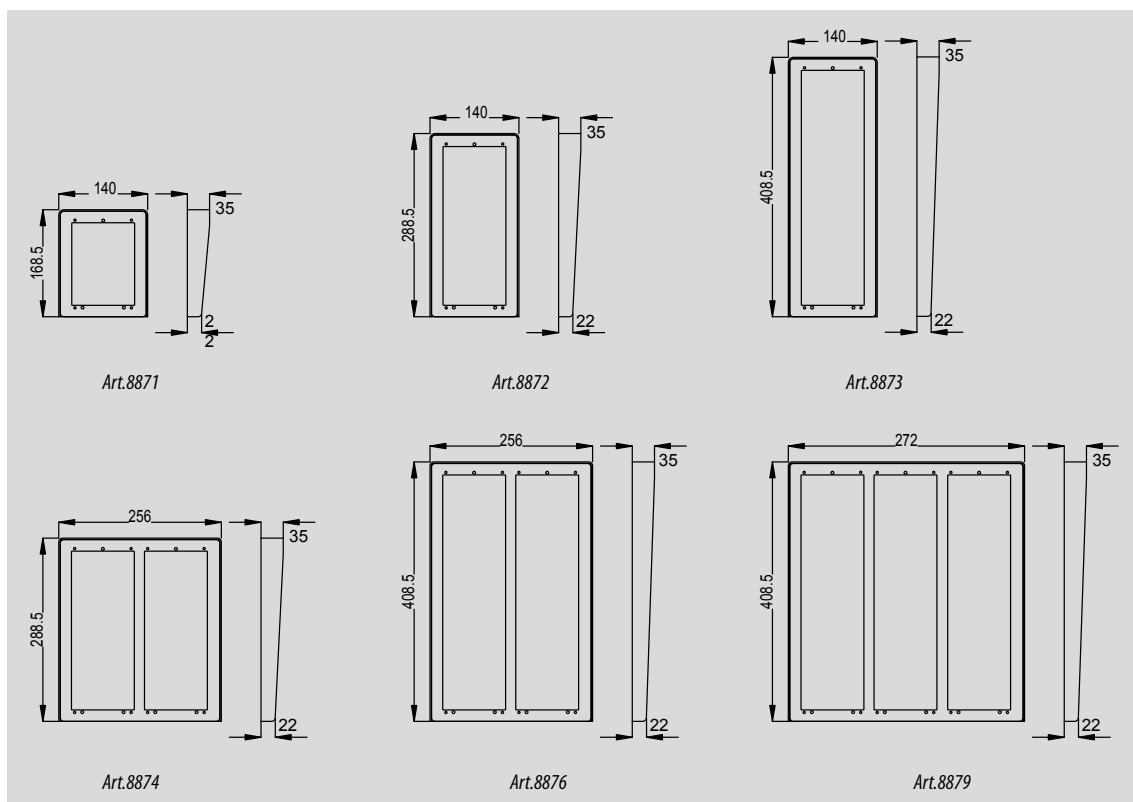

### RAINSHIELD

Complete with frame to be mounted between the front frame and the flush back boxes.  
To protect against rain and to cover cut outs in the wall. Projection: 35 mm. Max.

Art.	MODULES	COLUMNS	DIMENSIONS (mm)
8871	1	1	140x168,5x35
8872	2	1	140x288,5x35
8873	3	1	140x408,5x35
8874	4	2	256x288,5x35
8876	6	2	256x408,5x35
8879	9	3	372x408,5x35



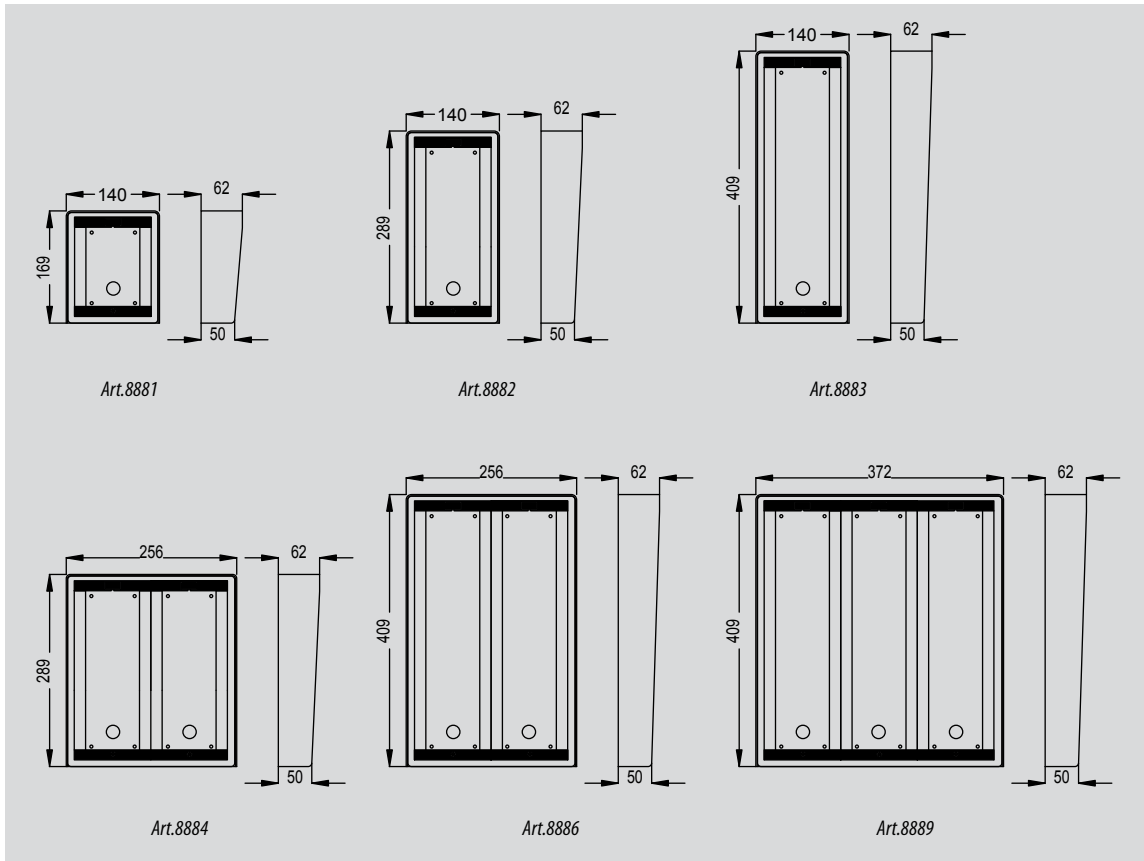

### SURFACE MOUNTING UNIT

Complete with hinge and front frame support for modules.  
Projection: 62 mm Max.

Art.	MODULES	COLUMNS	DIMENSIONS (mm)
<b>8881</b>	1	1	140x169x62
<b>8882</b>	2	1	140x289x62
<b>8883</b>	3	1	140x409x62
<b>8884</b>	4	2	256x289x62
<b>8886</b>	6	2	256x409x62
<b>8889</b>	9	3	372x409x62



Art.8882/A