

Installation Manual

for
6038V & 8VK (8000 series) Wireless Intercom System

Installation

- 1) Before installing fully, test the range of the system. Wire the unit as per wiring diagram, place the equipment in the desired location and test operation.
- 2) Ensure that the gate transmitter / receiver unit is installed to facilitate line of sight with the property or reception area. To achieve best results, mount the unit as high as possible from the ground. Should you need to extend range, you can mount it on a small pole to elevate it a few meters from the ground.

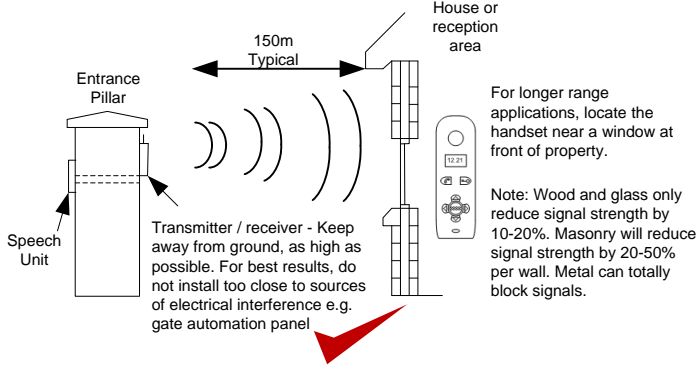

- 3) It is recommended to charge the handset for 7-8 hours before use.
- 4) Power up the handset after inserting the batteries.
- 5) Wire the door station and transmitter / receiver according to the diagram below..

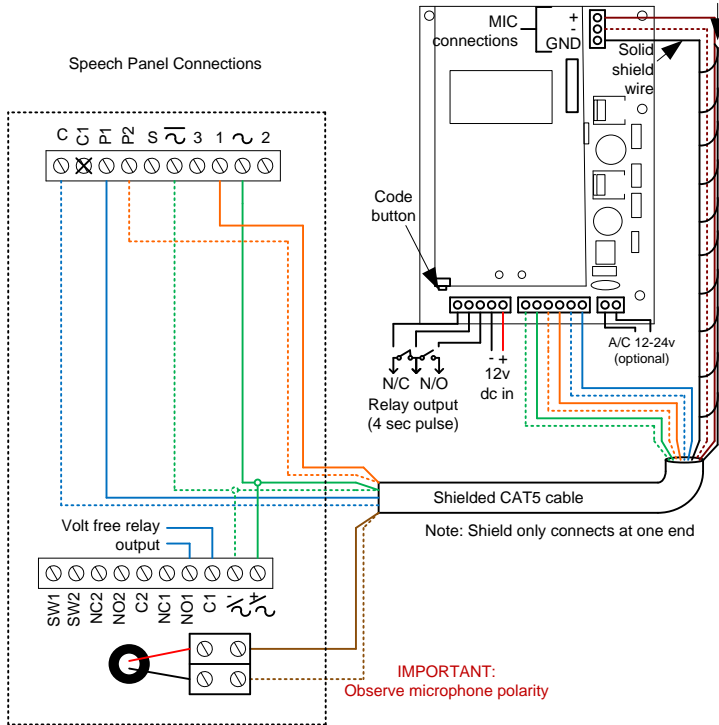
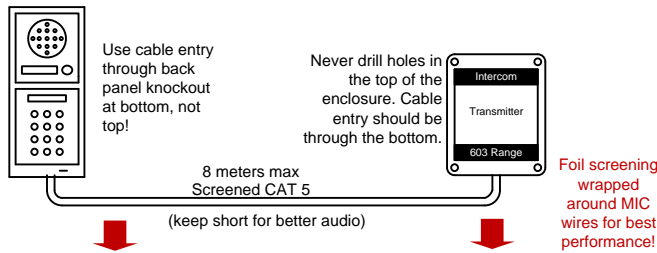

Testing

- 1) Check all connections are correct before switching on the power.
- 2) Press the call button on the speech panel.
- 3) The handset should ring.
- 4) Press the button to answer the call and check two way speech.
- 5) Press to check the door / gate release function works.

Handset & Operation

ADJUST VOLUME

Press Δ or ∇ to adjust volume level, and press MENU to select and save.

CHANGE RING TONE

Press \triangleleft and the unit will ring under the currently select tone. Press ∇ and Δ to cycle through available ring tones. Press MENU to select and save.

CHANGE LANGUAGE

Press \triangleright and the unit will display the currently selected language.

1=English. Press ∇ and Δ to cycle. Press MENU to select and save.

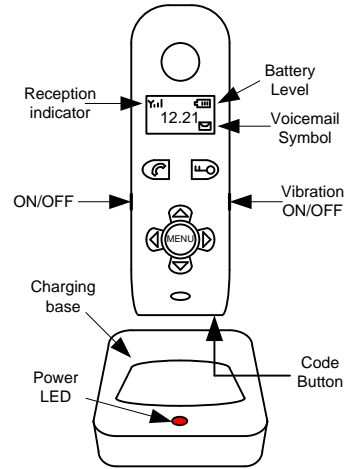

VOICEMAIL

When the door station is pressed, and not answered within 40 seconds, the visitor can leave a message. Once complete, the handset will display the symbol. Up to 16 messages can be saved.

To listen to voicemail, press MENU to play. If there are more than 1 message, press Δ and ∇ to select the message required and press MENU to play.

- \triangleleft = Pause / Exit
- \triangleright = Continue
- = Delete, long press = delete all.

SET TIME ON DISPLAY

Press MENU for 2 seconds. The hour digits will begin flashing. Press Δ or ∇ to adjust. Press MENU to cycle from hour setting to minutes and repeat. Press MENU a third time to exit and save changes.

Coding another handset to the System

To add an extra handset to the system, follow the sequence below..

- 1) Press and HOLD the code button on the door station for 3 seconds, until the LED's on the bottom of the board start to flash.
- 2) Press and hold the Code button on the new handset ignoring the first short tone, until you hear a confirmation tone ("Di-Do-Do"). This may take up to 10 seconds.
- 3) Once the door station lights stop flashing, then you can test the system by pressing the call button on the door station. The new handset should ring. If not, repeat the process from the top.

Note: For earlier models, the existing master handset lights will flash after step 1. You will need to press the MENU button on the existing handset first, before proceeding to step 2 above.

Keypad Programming (only for VK model)

