



SFERA, speaker module with 4 call pushbuttons

342350

Description

Speaker module for 2 WIRE system.

The following devices can be connected to the speaker module:

- Colour camera module to realize the video systems item 342550
- Black and white camera module to realize video systems item 342510
- Nameplate module item 342200
- Pushbutton module item 342480
- Numeric digital call module item 342610
- Alphanumeric digital call module item 342600

All the described modules are connected to the speaker module by means of the appropriate multi-cables. The speaker module allows to make systems of up to 50 handsets and the opening of an electric door lock directly connected between clamps S+ S- (18 V 4 A impulsive, 250 mA holding current). The door lock can be locally supplied by a transformer or using the actuators 346230 or item 346260.

Related items

- 332321 (speaker module front cover, 2 pushbuttons - Allmetal)
- 332341 (speaker module front cover, 4 call pushbuttons - Allmetal)
- 332322 (speaker module front cover, 2 pushbuttons - White)
- 332342 (speaker module front cover, 4 call pushbuttons - White)
- 332323 (speaker module front cover, 2 pushbuttons - Alugray)
- 332343 (speaker module front cover, 4 call pushbuttons - Alugray)

Technical data

- Power supply from SCS BUS: 18 – 27 Vdc
- Stand by absorption: 25 mA
- Max. operating absorption: 75 mA
- Operating temperature: (-25)-(+70)°C

Dimensional data

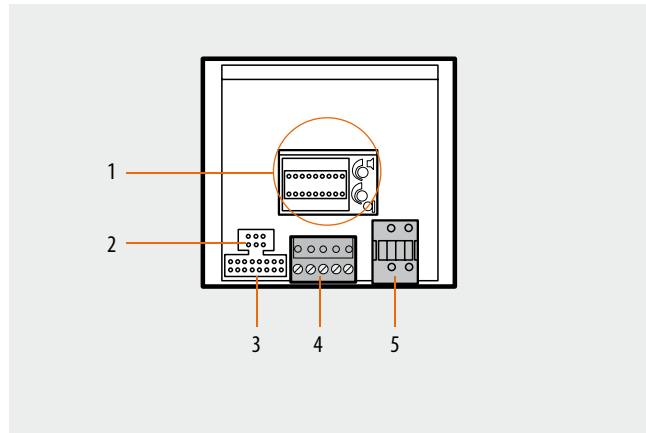
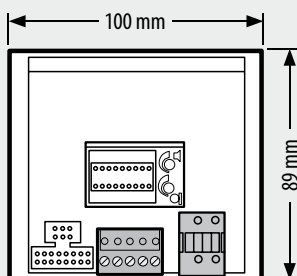

Legend

- 1 - Socket for configurators and potentiometers to adjust the microphone and loudspeaker volume, jumper for adaptation to the type of door lock and the alphanumeric call module.
- 2 - Connection socket for the camera connector.
- 3 - Socket for the connection of the nameplate module, the pushbutton module or the digital call module.
- 4 - Removable connector for the connection of the BUS, the electrical door lock, and the entrance hall door lock release pushbutton.
- 5 - Removable connector for the connection of the additional power supply.

Configuration

The device must be physically configured as follows:

P - entrance panel number

The configurator in socket P of the speaker module assigns to this a recognition number inside the system.

The numbering of the entrance panels must always start from P=0.

The entrance panel configured with P=0 must be a common (or main) entrance panel.

N - call number

Assigns the correspondence between the entrance panel pushbuttons and the audio handsets or video handsets. In the common entrance panels made with pushbutton modules, 1 must be inserted in N of the speaker module. The number of the first riser handset must be inserted in the local entrance panels in N. When the entrance panel is made with speaker module and digital call module (item 342630 or item 342610) no configurator must be inserted in N.

T – Door lock control time delay

configurator number

| | | | | | | | |
|--------------------|--------|--------|--------|--------------|--------|--------|---------|
| 0= No configurator | 1 | 2 | 3 | 4* | 5 | 6 | 7 |
| 4 sec. | 1 sec. | 2 sec. | 3 sec. | as pushbutt. | 6 sec. | 8 sec. | 10 sec. |

* **Operation as pushbutton for 10 sec. max**, after which standby mode is activated. To extend operation time over 10 seconds, use actuator item 346200 configured with **MOD=5**.

S - type of call signal

The configuration of S determines the call tone of SPRINT handsets. One can thus differentiate the calls from different entrance panels.

Table for SPRINT handset call signal

| Configurator | 0 | 1 | 2 | 3 |
|--------------|--------|--------|--------|----------|
| Type of bell | 2-tone | 2-tone | 2-tone | One-tone |
| | 1200Hz | 1200Hz | 1200Hz | 1200Hz |
| | 600Hz | 0 Hz | 2400Hz | |

For the SWING, PIVOT, POLYX and AXOLUTE handsets, the **S configurator** associates the entrance panel to the bell programmed in the same apartment. It is possible to chose between 16 different bells.

In one-family systems, **S=9 configures the general call** and the handsets ring, the same as with the S=0.

JUMPERS (JMP1) and (JMP2) - Critical door lock power supply:

Remove the JMP1 and JMP2 jumpers to connect to the speaker module a door lock with independent power supply.

JUMPER (JMP3) - EP local power supply

Remove the JMP3 jumpers when the speaker module is powered by an additional power supply.

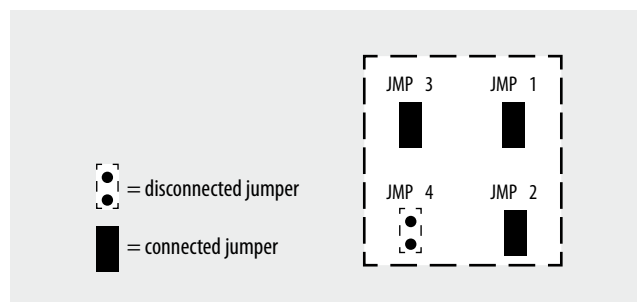

Installation and connection

Supplied as standard with the speaker module is a closing accessory with connector. The accessory must be fitted in the last pushbutton module of the pushbutton panel, after connecting the modules to each other using the multicables with connectors. It must not be used if the pushbutton panel only consists of a 1 or 2 pushbutton speaker module, in addition to a camera module that may be installed.

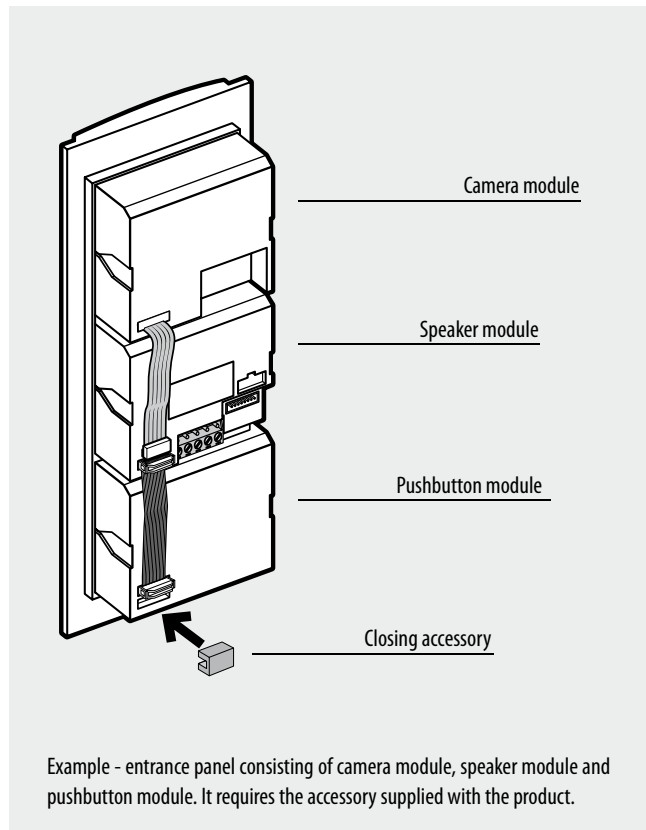
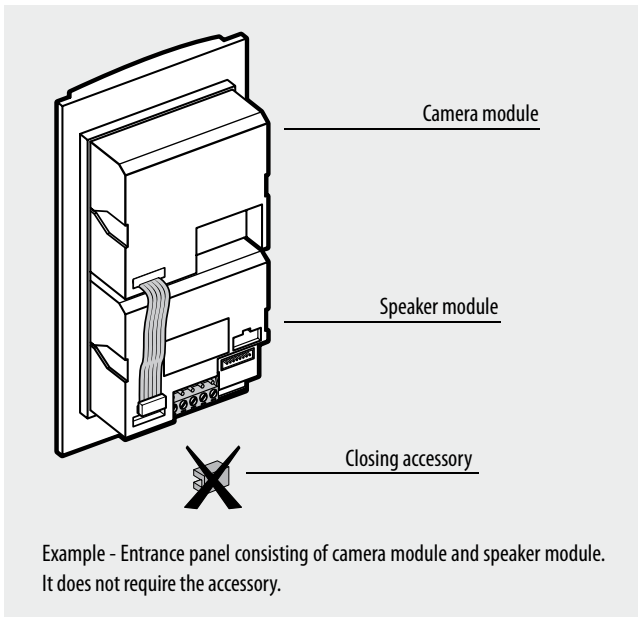

- In order to connect several key modules vertically on different columns, item 346092 must be used, fitting the closing accessory in the last module.

