

IT

EN

FR

NL

DE

ES

PT

MANUALE TECHNICAL MANUEL TECHNISCHE TECHNISCHES MANUAL MANUAL
TECNICO MANUAL TECHNIQUE HANDLEIDING HANDBUCH TÉCNICO TÉCNICO

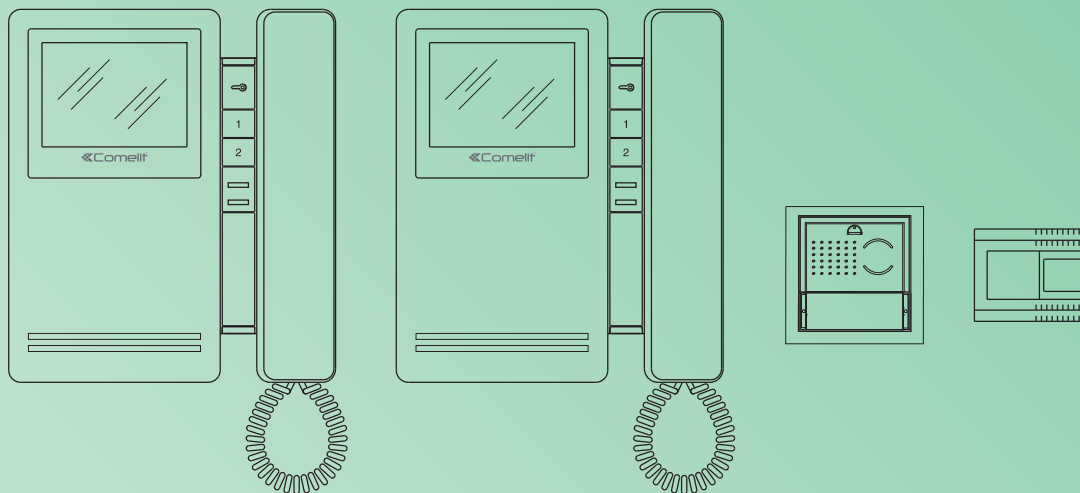

Manuale tecnico Magis Kit bifamiliare Art. 8172IMC

Technical manual for two-family Magis Kit Art. 8172IMC

Manuel technique Magis Kit deux usagers Art. 8172IMC

Technische handleiding Magis Kit tweegezinswoning Art. 8172IMC

**Technisches Handbuch Magis Kit Türsprechanlage
für Zweifamilienhaus Art. 8172IMC**

Manual técnico Magis Kit bifamiliar Art. 8172IMC

Manual técnico Magis Kit bifamiliar Art. 8172IMC

www.comelitgroup.com



 **Comelit**[®]
Passion and Innovation



Avvertenze

- Effettuare l'installazione seguendo scrupolosamente le istruzioni fornite dal costruttore ed in conformità alle norme vigenti.
- Tutti gli apparecchi devono essere destinati esclusivamente all'uso per cui sono stati concepiti. **Comelit Group S.p.A.** declina ogni responsabilità per un utilizzo improprio degli apparecchi, per modifiche effettuate da altri a qualunque titolo e scopo, per l'uso di accessori e materiali non originali.
- Tutti i prodotti sono conformi alle prescrizioni delle direttive 2006/95/CE (che sostituisce la direttiva 73/23/CEE e successivi emendamenti) e ciò è attestato dalla presenza della marcatura **CE** sugli stessi.
- Evitare di porre i fili di montante in prossimità di cavi di alimentazione (230/400V).
- Non inserire oggetti né versare liquidi all'interno del dispositivo.
- Gli interventi di installazione, montaggio e assistenza agli apparecchi elettrici devono essere eseguiti esclusivamente da elettricisti specializzati.
- Togliere l'alimentazione prima di effettuare qualsiasi manutenzione.
- Connettere il telaio porta moduli a terra (vedi Fig.)
- Non tenere premuto il gancio fonica con la cornetta sollevata.
- La telecamera non deve essere installata di fronte a grandi sorgenti luminose, oppure in luoghi dove il soggetto ripreso rimanga molto in controluce. Per risolvere il problema precedentemente descritto, si consiglia di modificare l'altezza di installazione della telecamera, solitamente 160 - 165 cm, ad un'altezza di 180 cm e di orientare l'obiettivo verso il basso in modo da migliorare la qualità delle riprese.
- Le telecamere con sensore CCD a colori, presentano in condizioni di scarsa luminosità, una sensibilità inferiore rispetto alle telecamere in bianco e nero. Si consiglia pertanto, in ambienti poco illuminati di prevedere una fonte di illuminazione aggiuntiva.

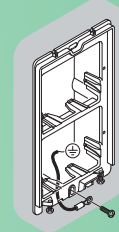

Generalità	3
Posto esterno	3
Art. 4879KC	3
Art. 1207	3
Installazione posto esterno	3
Inserimento cartellini portanome	4
Posti interni	5
Montaggio posto interno Magis	5
Sgancio del monitor	5
Art. 6402E	6
Descrizione monitor	6
Art. 2608	7
Installazione citofono Art. 2608	7
Indicazioni generali di installazione e funzionamento	8
Tabella distanze di funzionamento	8
Funzionamento	8
Descrizione impostazioni e funzionamento pulsanti	9
Impostazione monitor Art. 6402E e citofono Art. 2608	9
TAB. A Indirizzi di montante	9
Descrizione funzione Pulsanti	9
Monitor supplementari principali o secondari	10
Utilizzo kit in impianti con porta principale	10
Programmazione pulsanti Art. 4680KC	11
Configurazioni pulsanti di default	11
Avvertenze generali programmazione pulsanti	11
Programmazioni pulsanti per attuatore generico o indirizzato	12
Programmazioni per chiamata intercomunicante	12
Programmazione/cancellazione indirizzo intercomunicante (solo per intercomunicante selettivo)	12
TAB. B Indirizzi intercomunicante selettivo	12
Programmazioni pulsanti per chiamata intercomunicante	13
Programmazioni pulsanti per altre funzioni	13
TAB. C Indirizzi di montante	14
Reset programmazione	14
Programmazione range/suonerie	15
Programmazione ingresso IN1 per segnalazione led/allarme/apriporta/attuatore	16
Programmazione diretta chiamata intercomunicante	17
Variazione suonerie monitor	17
Programmazioni speciali Art. 4680KC	18
Schemi di collegamento	
MSK/018IC Schema base per kit bifamiliari Art. 8172IMC con collegamento in cascata	121
MSK/013IBC Schema base per kit bifamiliari Art. 8172IMC con collegamento in derivazione	122
MSK/014IBC Schema per kit bifamiliari Art. 8172IMC ampliati con un secondo Art. 4879KC. Collegamento in derivazione	124
MSK/014IAC Schema per kit bifamiliari Art. 8172IMC ampliati con un secondo Art. 4879KC. Collegamento in cascata	124
MSK/018I/AC Schema per kit bifamiliare con alimentatore aggiuntivo Art. 1595	125
MSK/019IC Utilizzo modulo telecamera scorpolata Art. 1259C.....	126
PXK/EC Collegamento relé attuatore Art. 1256	127
MSK/EN/109IC Schema per connessione a porta principale da 2 a 9 Magis Kit tramite Art. 4834/9	128
MSK/EN/110IC Schema per connessione a porta principale di 30 Magis Kit (massimo). Collegamento Magis in cascata con Art. 1424.....	130
SB2/AAR Collegamento amplificatore video Art. 4833C.....	132
MSK/HCA Aggiunta di un monitor principale in parallelo. Collegamento in cascata	132
MSK/IC Aggiunta di un monitor principale in parallelo. Collegamento in derivazione	133
MSK/A20S Collegamento in cascata del terzo monitor principale con alimentazione locale.....	133
MSK/A23S Collegamento in derivazione di 2 monitor principali e di 2 monitor secondari con lo stesso codice utente	134
MSK/A21S Collegamento in cascata di 2 monitor principali e di 1 monitor secondario con lo stesso codice utente	134

MSK/AAE Collegamento citofoni aggiuntivi in derivazione dal monitor.....	135
MSK/AAD Collegamento citofoni aggiuntivi in cascata dal monitor	135
MSK/FC Aggiunta di un citofono in parallelo in derivazione dal montante.....	136
SB/X3 Utilizzo per usi vari del pulsante P1 (Art. 2608)	136
SB2V/AAK Connessione di dispositivi di ripetizione di chiamata (Art. 1229 o Art. 1122/A).....	137
Variante collegamento chiamata fuori porta.....	137
Utilizzo ingresso IN1 come contatto per segnalazione LED/ALLARME/APRIORTA/ATTUATORE. Attivazione in chiusura verso CFP2.....	138
Utilizzo ingresso IN1 come contatto per segnalazione LED/ALLARME/APRIORTA/ATTUATORE. Attivazione in presenza di tensione rispetto a IN2.	138
SB2/AAM2 Utilizzo per usi vari del pulsante P1	139
PXX/RTNP Utilizzo relé posto esterno su apriporta o comando attuatore.....	139
PXX/SNP Variante con serratura di sicurezza e alimentazione aggiuntiva	140
Utilizzo della rete RC per filtro serratura sui contatti del relé	140
PXX/DO Variante utilizzo segnalazione porta aperta.	141

Generalità

I Kit video citofonici bifamiliare Art. 8172IMC sono utilizzabili in edifici civili o terziari dove è richiesto un'efficace controllo di accesso a fronte di semplici operazioni di installazione.

Infatti bastano 2 conduttori tra il posto esterno e il/i monitor interni per attivare il sistema (chiamata, fonica, video, autoaccensione), più 2 fili per alimentare il posto esterno e l'elettroserratura e 2 fili per alimentare il posto interno videocitofonico.

È disponibile inoltre una vasta gamma di accessori per risolvere facilmente ogni esigenza di impianto; infatti oltre a interessanti accessori di tipo standard è possibile ampliare l'impianto aggiungendo videocitofoni e/o citofoni e/o posti esterni. In questo modo si può raggiungere un massimo 2 posti esterni con 8 posti interni tra Citofoni e Videocitofoni (4 per Pulsante di chiamata) per la configurazione bifamiliare.

Tramite opportune impostazioni è possibile effettuare comunicazioni intercomunicanti monofamiliari (cioè tra utenti con il medesimo codice utente) utilizzando sia videocitofoni che citofoni.

Più Kit possono essere connessi a una porta principale Simplebus e/o a un centralino Art. 1998A.

Posto esterno

Art. 4879KC

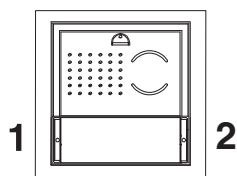

Art. 4879KC

Caratteristiche tecniche

Connessione al monitor con 2 fili per audio, video, apriporta e chiamata più 2 fili per alimentazione da Art. 1207.

Telecamera orientabile ad alta sensibilità con sensore CCD 1/3".

Cartellini portanome con illuminazione a led selezionabile tra blu, bianca e spenta.

Regolazione volume altoparlante.

Dimensione scatola da incasso: 118x118x45 mm.

I pulsanti dell'Art. 4879KC è impostato di fabbrica per effettuare la chiamata agli indirizzi 1 (pulsante sinistro) e 2 (pulsante destro).

Dimensione posto esterno: 112x89,5x40 mm.

Descrizione morsettiera

LL connessione monitor (video, chiamata, fonica, apriporta).

V+ V- alimentazione posto esterno.

RTE ingresso apriporta locale temporizzato.

DO ingresso segnalazione porta aperta.

PR morsetto di programmazione.

GND morsetto negativo da utilizzare in fase di programmazione.

NO NC COM contatti del relé da 10A.

SE connessione elettroserratura.

Art. 1207

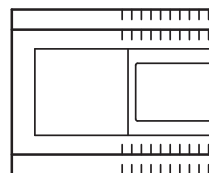

Caratteristiche tecniche

Il trasformatore prevede 2 uscite: una per alimentare il posto esterno e l'elettroserratura, l'altra per alimentare il monitor.

Dimensioni: 105x85x85 mm (6 moduli DIN).

Protetto da cortocircuiti e sovraccarichi.

Descrizione morsettiera

L $\frac{1}{2}$ N ingresso tensione di rete 110-240 VAC.

+22V 0V uscita DC di alimentazione del monitor.

+33V 0V uscita DC per posto esterno e elettroserratura.

Installazione posto esterno

► Lasciare in posizione la protezione di impianto

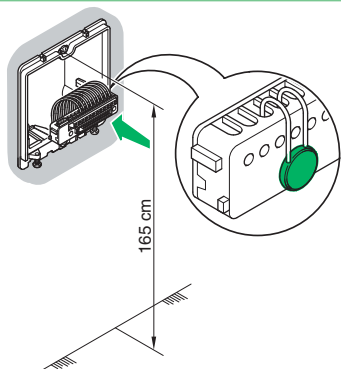

1

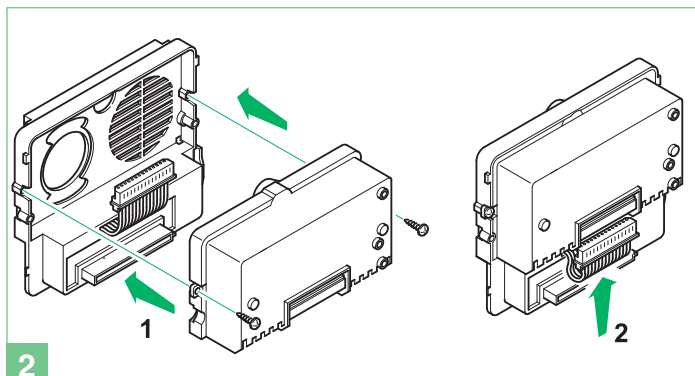

2

► Selezione illuminazione led cartellini portanome

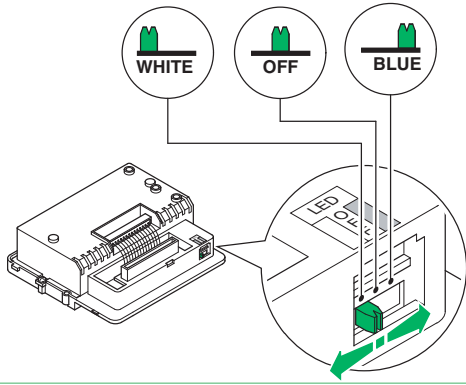

3

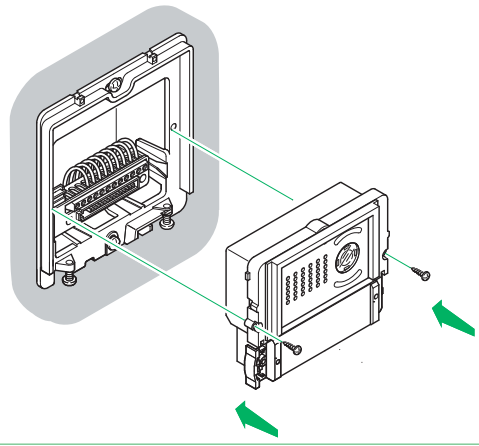

4

Posizione alternativa del microfono

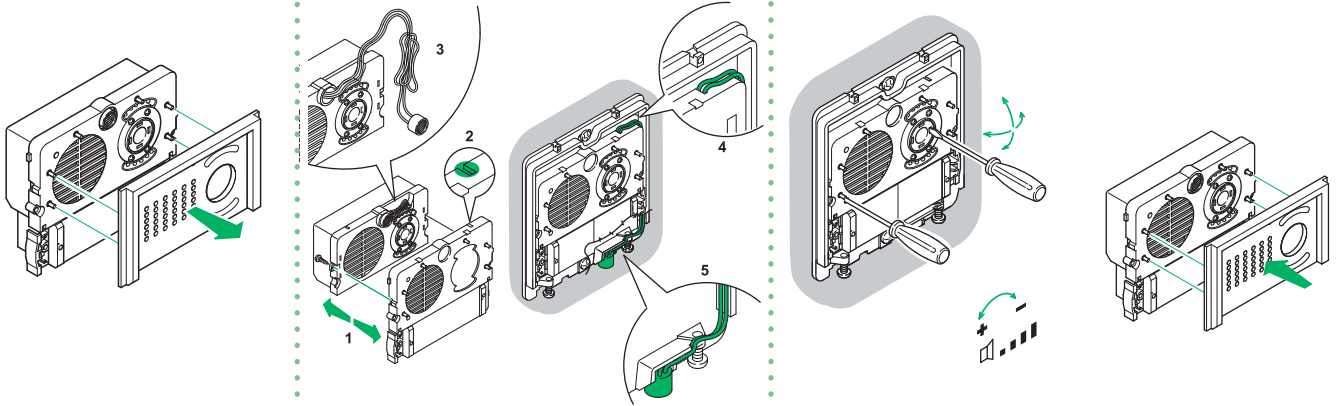

4A

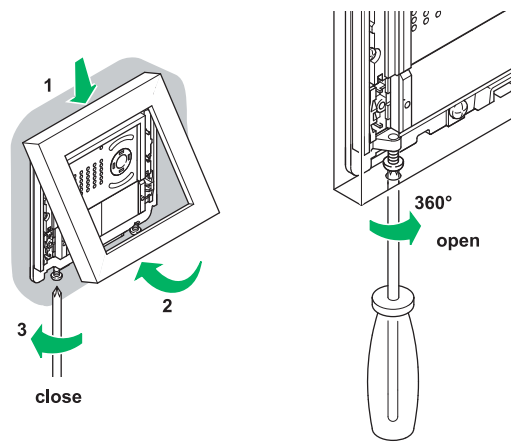

5

Inserimento cartellini portanome

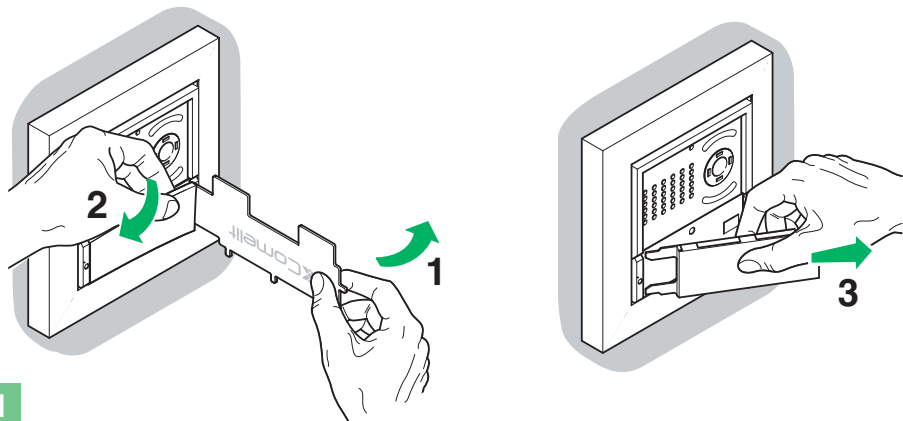

1

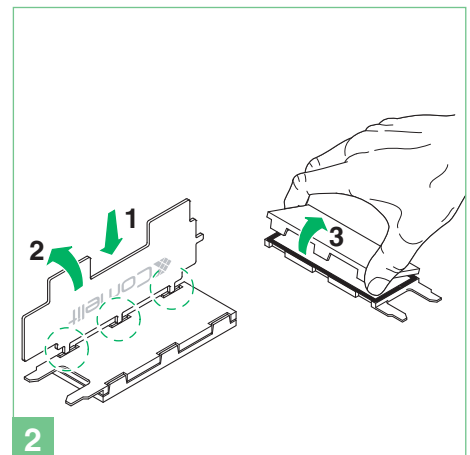

2

► Centrare il cartellino per evitare infiltrazioni

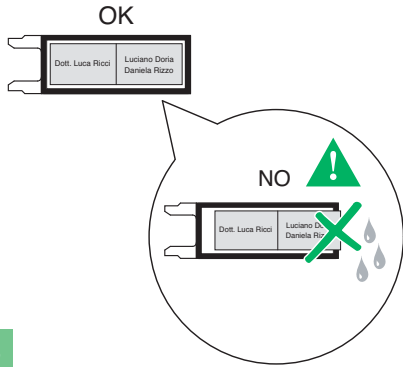

3

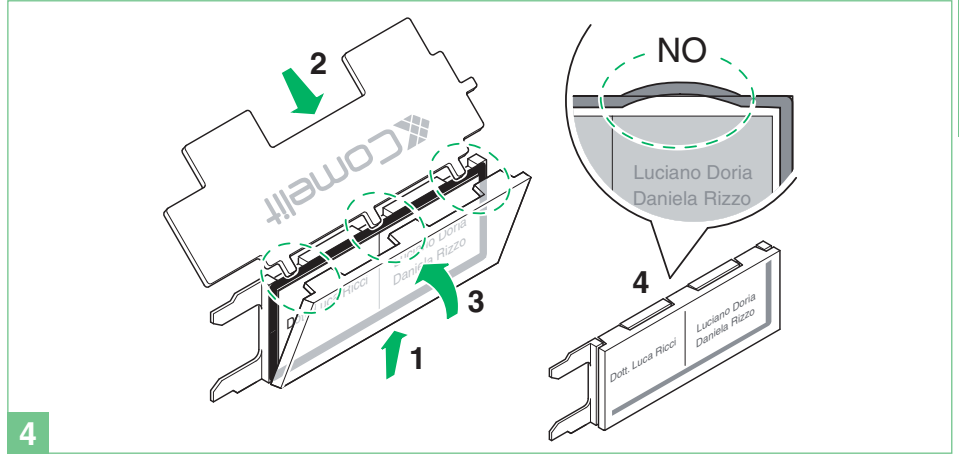

4

Posti interni

Montaggio posto interno Magis

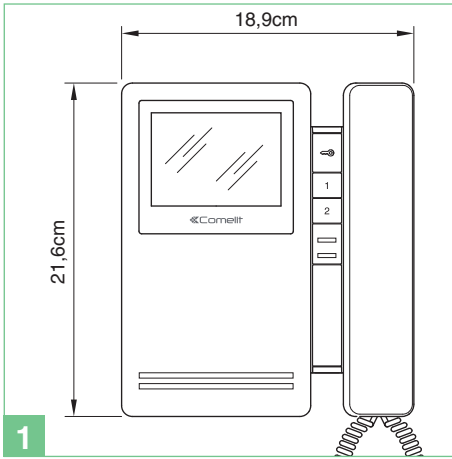

1

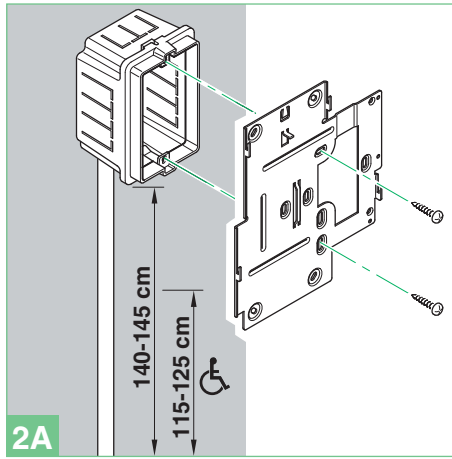

2A

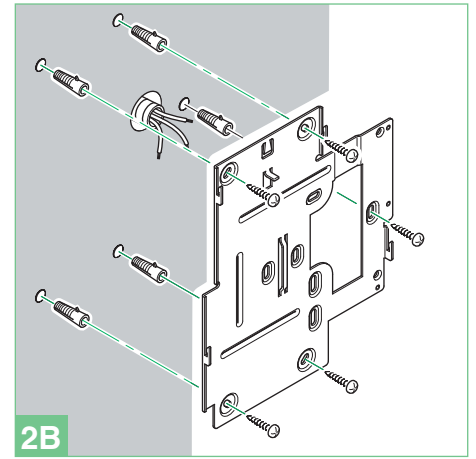

2B

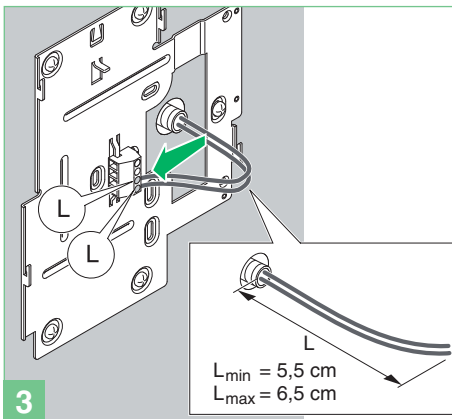

3

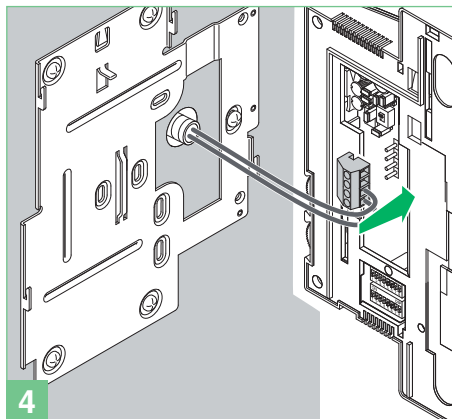

4

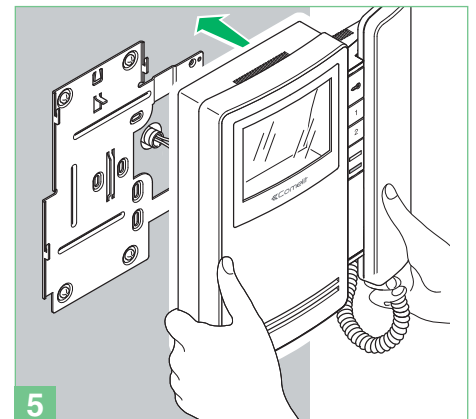

5

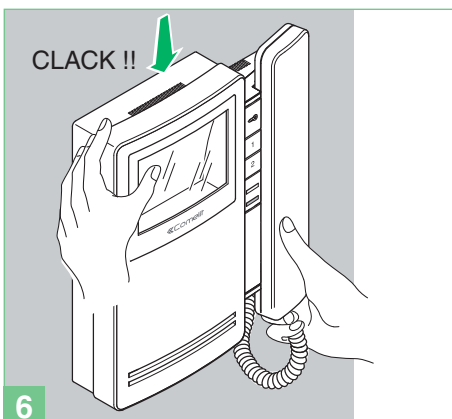

6

Sgancio del monitor

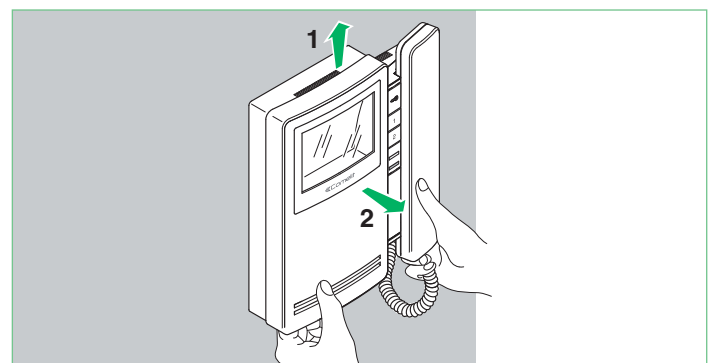

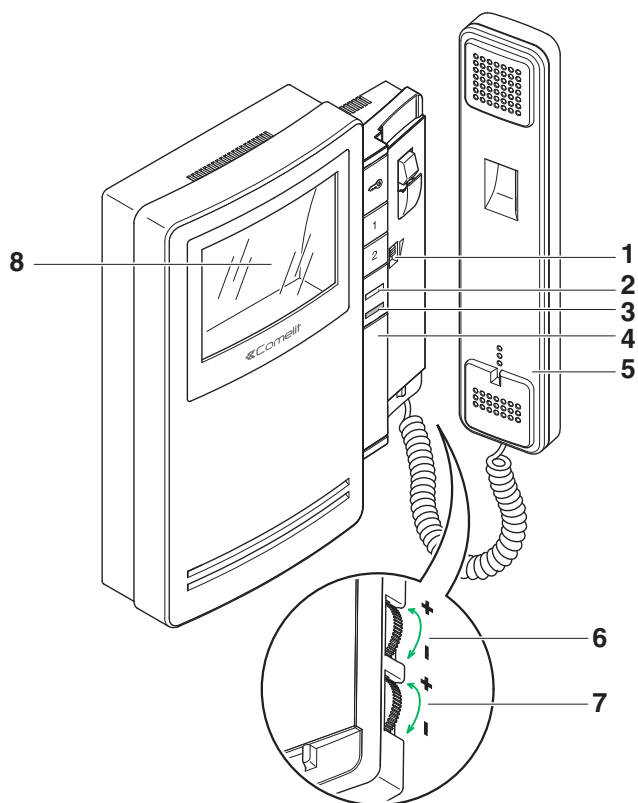

Descrizione monitor:

- 1 Regolazione volume chiamata / selettore funzione Privacy (per servizio Privacy si intende l'esclusione della chiamata dal posto esterno e da citofoni o videocitofoni intercomunicanti; l'attivazione della funzione privacy è evidenziata dalla comparsa di un indicatore rosso a lato del selettore).
- 2 Led di segnalazione impianto occupato/funzione dottore attiva/porta aperta.
- 3 Indicatore rosso - privacy attivata.
- 4 Spazio alloggiamento pulsanti supplementari con accessorio Art. 6433, Art. 6434.
- 5 Cornetta Monitor (sollevare la cornetta per iniziare la comunicazione).
- 6 Manopola regolazione intensità colore.
- ▶ Per aumentare il valore ruotare in senso antiorario.
- 7 Manopola regolazione luminosità.
- ▶ Per aumentare il valore ruotare in senso antiorario.
- 8 Schermo a colori 3,5".

Descrizione pulsanti:

- ☞ Pulsante apriporta.
- 1 Tasto 1 attuatore generico (programmabile).
- 2 Tasto 2 autoaccensione (programmabile).

Descrizione monitor

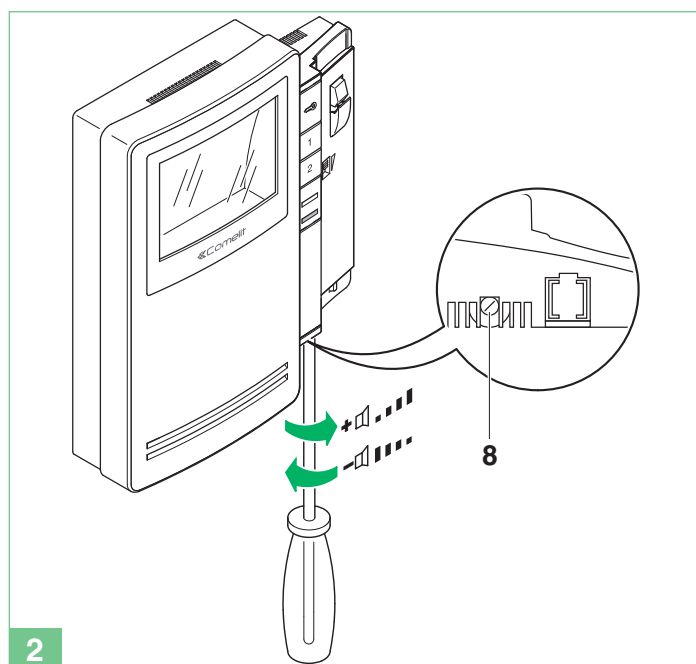
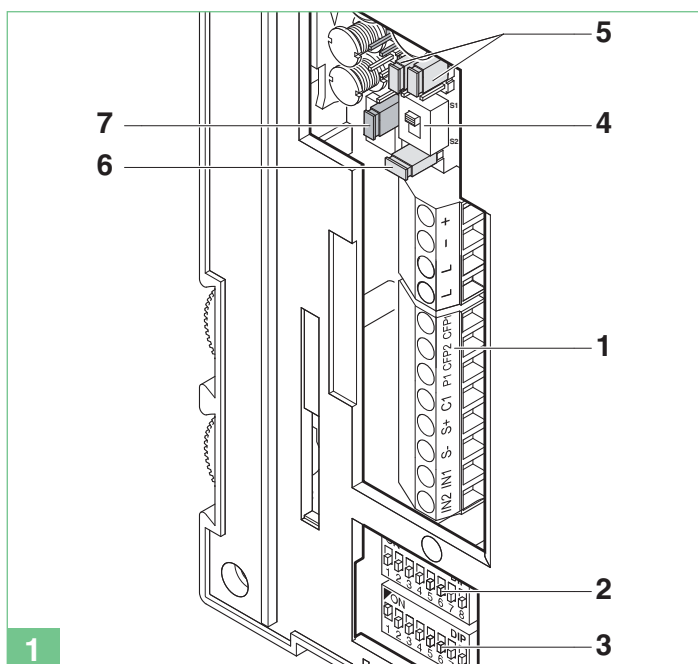

- 1 Morsettiera per connessione impianto:
 + - Morsetti per alimentazione.
 L L Morsetti di connessione linea Bus.
 CFP1 CFP2 Ingresso chiamata da piano.
 P1 C1 Morsetti Pulsante 1 per servizi vari.
Per avere un contatto C.NO. (24V-100mA max) spostare in posizione B i jumper CV3 e CV4.
 S+ S- Morsetti per dispositivo ripetizione di chiamata.
 IN1 IN2 Ingresso LED (programmabile).
- 2 S1 Micro-interruttori per programmazione codice utente.
- 3 S2 Micro-interruttori per programmazione pulsanti e funzioni (identificato da angolo rosso):
 DIP 1-2-3-4 per programmazione funzioni pulsanti.
 DIP 5-6 accesso programmazioni.

- DIP 7 per gestione tensione di alimentazione (vedere schemi e varianti da pag. 121) default = OFF.
- DIP 8:
 ON staffa secondaria.
 OFF staffa principale (default).
- 4 SW3 Selettore per modalità Simplebus 1 (S1- default) o Simplebus 2 (S2).
- 5 CV3 CV4 Jumper per liberare il pulsante 1 (contatto C.NO. 24V-100mA max).
 A pulsante 1 attuatore generico (default) o programmabile.
 B pulsante 1 per usi vari.
- 6 CV5 Jumper chiusura video.
- 7 CV6 Selettore per utilizzo ingresso IN 1 (vedi pag. 138).
- 8 Regolazione volume altoparlante (solo per settaggio fonica intercomunicante).

Art. 2608

Non è utilizzabile per sfruttare la funzione intercomunicante.
Il citofono va montato sempre utilizzando l'Art. 1214/2C come mostrato nello schema di collegamento MSK/FC a pag. 136.

- 1 Indicatore funzione Privacy.
- 2 Selettore suoneria/servizio Privacy a 3 posizioni:
Posizione alto: Suoneria volume massimo.
Posizione centrale: Suoneria volume medio.
Posizione basso: Attivazione funzione Privacy.
(Per servizio Privacy si intende l'esclusione della chiamata dal posto esterno e centralino; l'attivazione della funzione Privacy è evidenziata dalla comparsa di un indicatore rosso in alto a destra).
- 3 Trimmer regolazione volume microfono.
- 4 Micro-interruttori per impostazione codice utente.
- 5 Morsetti connessione impianto:
L L Connessione alla linea bus.
CFP CFP Ingresso chiamata da piano.
P1 C1 Morsetti Pulsante P1 per servizi vari (contatto C. NO. 24V-100mA max) (rimuovere CV1 e CV2, vedi variante SB/X3 pag. 136).
S+ S- Morsetti per dispositivo ripetizione di chiamata.
- 6 CV1 CV2 Jumper da rimuovere per avere contatto pulito C.NO. sul pulsante P1.
- 7A/7B JP1 Jumper per selezionare la funzione Chiamata centralino (posizione C)/Attuatore generico (posizione A) del pulsante P1.

Descrizione pulsanti:

- ⏏ Pulsante Apriporta.
- P1 Pulsante P1 chiamata centralino/attuatore generico/pulsante per servizi vari presente in morsetteria (P1 C1).

Pulire con un panno inumidito con acqua. Evitare Alcool e altri prodotti aggressivi.

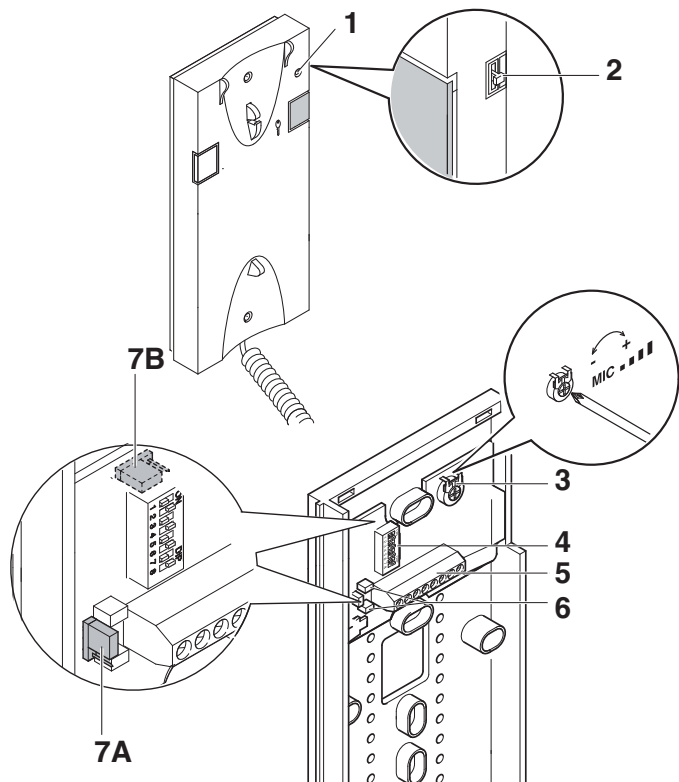

Installazione citofono Art. 2608

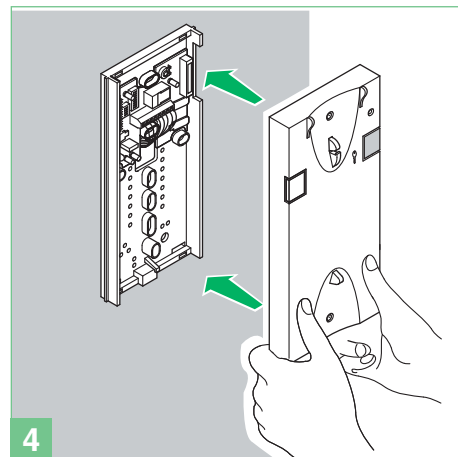
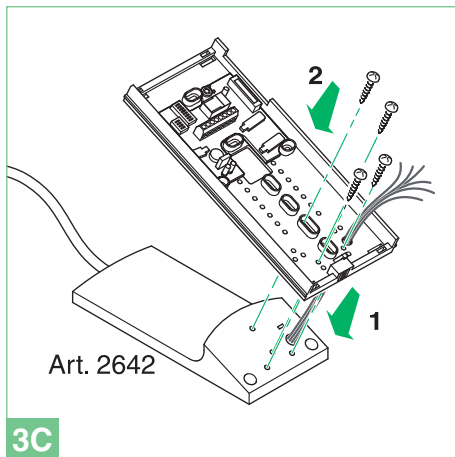
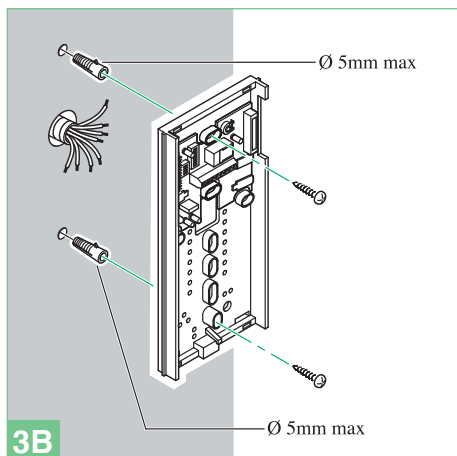
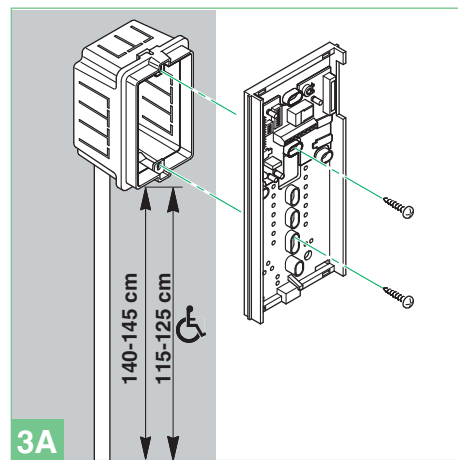
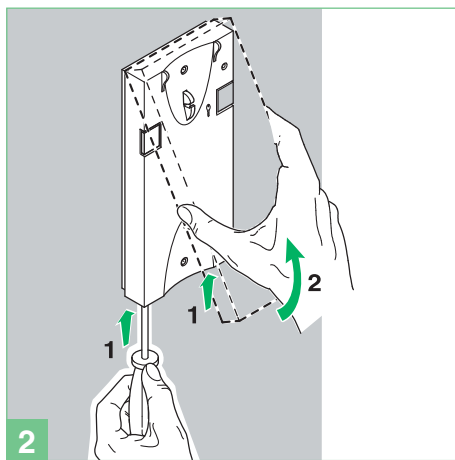
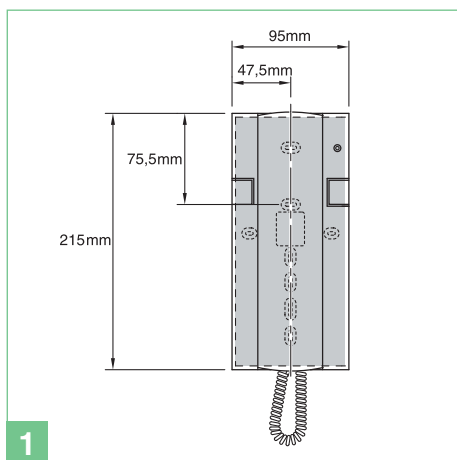

Indicazioni generali di installazione e funzionamento

La distanza massima totale tra il posto esterno e il monitor più lontano è 400 m (con amplificatore Art. 4833C).

La somma totale del numero di posti interni con stesso codice utente e del numero di dispositivi di ripetizione chiamata collegati ai suddetti posti interni non può superare il numero di 4.

Connettere un solo dispositivo di ripetizione chiamata per ogni posto interno.

La distanza MAX del collegamento tra posto interno e dispositivo di ripetizione chiamata è di 20m; utilizzare cavo schermato per il collegamento e non far passare i cavi in prossimità di carichi induttivi pesanti o cavi di alimentazione (230V / 400V).

Tabella distanze di funzionamento

		A/G MAX	B/E MAX	C MAX	D MAX	F MAX	Art. 1216
Comelit Art. 4577 1 mm ² (Ø 1,2 mm AWG 17)		50 m (165 feet)	50 m (165 feet)	200 m (655 feet)	100 m (330 feet)	150 m (495 feet)	
Comelit Art. 4576-4578	0,5 mm ² (Ø 0,8 mm AWG 20) bus		25 m (85 feet)	200 m (655 feet)	100 m (330 feet)	150 m (495 feet)	
	1,5 mm ² (Ø 1,4 mm AWG 15) power	75 m (245 feet)	100 m (330 feet)				
UTP5 cat. 5 0,2 mm ² (Ø 0,5 mm AWG 24)				190 m (625feet)	60 m (195 feet)	150 m (495 feet)	
0,28 mm ² (Ø 0,6 mm AWG 23)		5 m (15 feet)		190 m (625 feet)	60 m (195 feet)	150 m (495 feet)	
0,5 mm ² (Ø 0,8 mm AWG 20)		25 m (85 feet)	25 m (85 feet)	190 m (625 feet)	60 m (195 feet)	150 m (495 feet)	
1 mm ² (Ø 1,2 mm AWG 17)		50 m (165 feet)	50 m (165 feet)	190 m (625 feet)	60 m (195 feet)	150 m (495 feet)	
1 mm ² (Ø 1,2 mm AWG 17)		50 m (165 feet)	50 m (165 feet)	120 m (395 feet)	40 m (130 feet)	100 m (330 feet)	
1,5 mm ² (Ø 1,4 mm AWG 15)		75 m (245 feet)	100 m (330 feet)	190 m (625 feet)	60 m (195 feet)	150 m (495 feet)	
2,5 mm ² (Ø 1,8 mm AWG 13)		100 m (330 feet)	150 m (495 feet)	190 m (625 feet)	60 m (195 feet)	150 m (495 feet)	

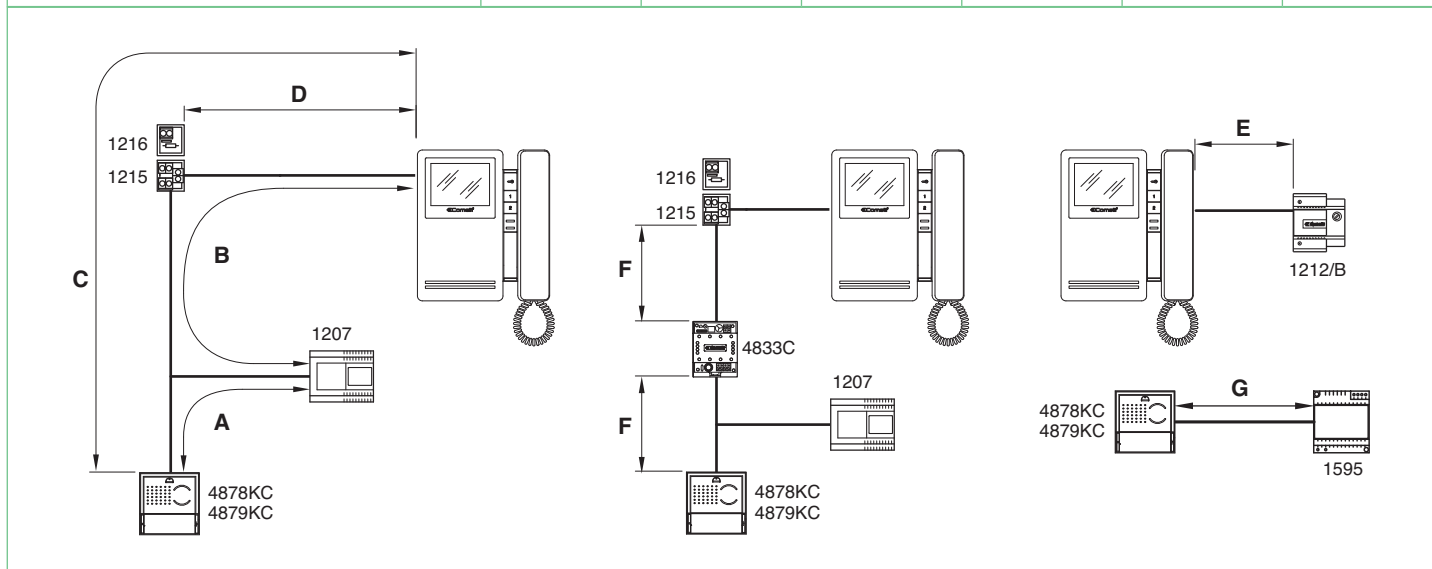

Funzionamento



In caso di cortocircuito persistente sulla linea bus il posto esterno emette un tono di segnalazione intermittente.

Il visitatore quando preme il tasto di chiamata accende l'illuminazione del soggetto, aziona la suoneria interna di chiamata (se la funzione privacy non è abilitata) e fa apparire l'immagine sul/sui monitor principale/i per circa 60".

La durata massima della conversazione tra posto esterno e posto interno è di 90".

Al posto esterno si ha un tono di avvenuta chiamata; se in impianti con 2 o più ingressi all'atto della chiamata, il posto esterno emette un tono di occupato invece che la replica della suoneria, significa che un'altra comunicazione è già in atto verso un altro posto esterno.

Per la programmazione di indirizzi utente diversi da quelli impostati di fabbrica (1 e 2) vedi pag. 9.

Per le funzionalità intercomunicanti del Sistema Magis Kit vedi pag.12.

Descrizione impostazioni e funzionamento pulsanti

Impostazione monitor Art. 6402E e citofono Art. 2608

Posizione dei microinterruttori del monitor Art.6402E

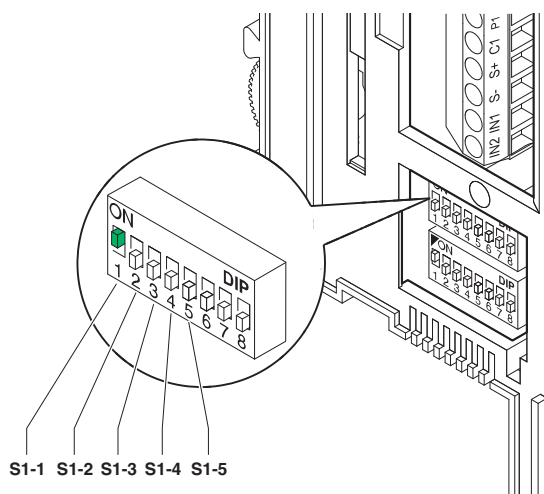

► Sui citofoni Art. 2608, Art. 2610 e Art. 2628 posizionare i dip **S1-6, S1-7, S1-8** su **OFF**

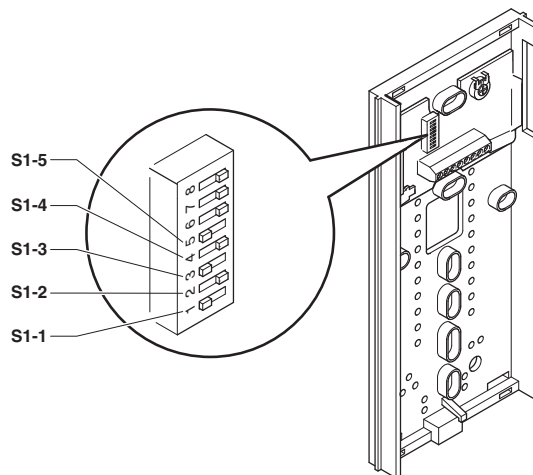

I valori di **S1-1, S1-2, S1-3, S1-4** e **S1-5** definiscono l'indirizzo di chiamata del monitor e dei citofoni come riportato nella seguente tabella.

TAB. A Indirizzi di montante

Codice	S1	Codice	S1	Codice	S1	Codice	S1
1		9		17		25	
2		10		18		26	
3		11		19		27	
4		12		20		28	
5		13		21		29	
6		14		22		30	
7		15		23			
8		16		24			

Descrizione funzione Pulsanti

La chiamata intercomunicante bifamiliare (tra citofoni e/o videocitofoni) è possibile solo se i 2 utenti sono impostati su codici di chiamata contigui (contrassegnati dalla stessa lettera AA..CC..OO nella tabella di programmazione dei micro interruttori riportata a pag. 9).

☞ **Apriporta:** La pressione del Pulsante Apriporta attiva la serratura connessa al posto esterno.

Attuatore: La pressione del Pulsante 1 impostato nella modalità Attuatore permette l'attivazione dell'Art. 1256 che può essere utilizzato ad esempio per attivare l'apertura di cancelli, porte basculanti o per l'attivazione del modulo telecamere cicliche Art. 1259/C.

Pulsante Libero: L'indicazione Pulsante libero indica la possibilità di utilizzare il Pulsante 1 come contatto C.NO. in morsettiera mediante opportune impostazioni come illustrato nella variante SB2/AAM2 pag.139.

Autoaccensione / Richiesta Video:

L'autoaccensione può essere disabilitata.

L'autoaccensione è possibile solo con impianto a riposo.

L'autoaccensione è consigliata solo per impianti con 1 o 2 ingressi.

La pressione del Pulsante 2 permette di visualizzare sullo schermo del Monitor l'immagine trasmessa dal posto esterno anche se non è stata effettuata nessuna chiamata.

In impianti dotati di due posti esterni, è possibile visualizzare alternativamente l'immagine da un posto esterno o dall'altro (funzione "bascula") con successive pressioni del Pulsante. L'autoaccensione è possibile solo ad impianto libero.

Su monitor secondari (**S2** DIP8 ON) il pulsante 2 ha anche la funzione di richiesta video, permette di accendere un monitor in seguito a una chiamata da posto esterno.

Abilitazione:

► premere il pulsante dedicato all'autoaccensione del monitor per un tempo superiore a 4 sec.

» suoneria di conferma.

Disabilitazione:

► premere il pulsante dedicato all'autoaccensione per un tempo superiore a 4 sec.

» 4 toni di conferma.

Accensione:

► premere e rilasciare immediatamente il pulsante dedicato (pulsante 2 - se mantenute le impostazioni di fabbrica).

Chiamata a centralino

La pressione del pulsante impostato in questa modalità permette di inviare una chiamata al centralino di portineria.

Chiamata intercomunicante monofamiliare

Questa funzione permette di inviare una chiamata agli altri apparecchi (videocitofoni e/o citofoni) impostati sullo stesso indirizzo di chiamata.

► Il ricevente della chiamata alzando la cornetta entra in comunicazione con il chiamante. Riagganciando la cornetta la comunicazione viene terminata. Una chiamata intercomunicante non è prioritaria rispetto ad una conversazione/chiamata con il posto esterno.

In questo caso, durante un tentativo di chiamata intercomunicante, il LED di segnalazione lampeggerà per alcuni secondi per segnalare che il sistema è occupato.

Chiamata da posto esterno

Una chiamata da posto esterno è sempre prioritaria rispetto a una comunicazione intercomunicante (l'attivazione della comunicazione con il posto esterno interrompe la conversazione intercomunicante precedentemente in corso). In questo caso gli utenti che si trovano già in

conversazione sentiranno in cornetta un tono simile a quello di chiamata se quest'ultima è indirizzata a loro o un triplice tono di segnalazione in caso contrario.

► Per rispondere alla chiamata da posto esterno è sufficiente sollevare la cornetta da qualunque apparecchio libero o riagganciare e sollevare la cornetta da un apparecchio impegnato nella comunicazione intercomunicante.

Dottore

Questa funzione permette l'azionamento automatico dell'apriporta su chiamata da posto esterno all'indirizzo del posto interno su cui la funzione è stata attivata.

Abilitazione/disabilitazione:

► tenere premuto per 2 sec. il pulsante impostato per tale funzione
» a funzione attivata il led di segnalazione rimane acceso.

Monitor supplementari principali o secondari

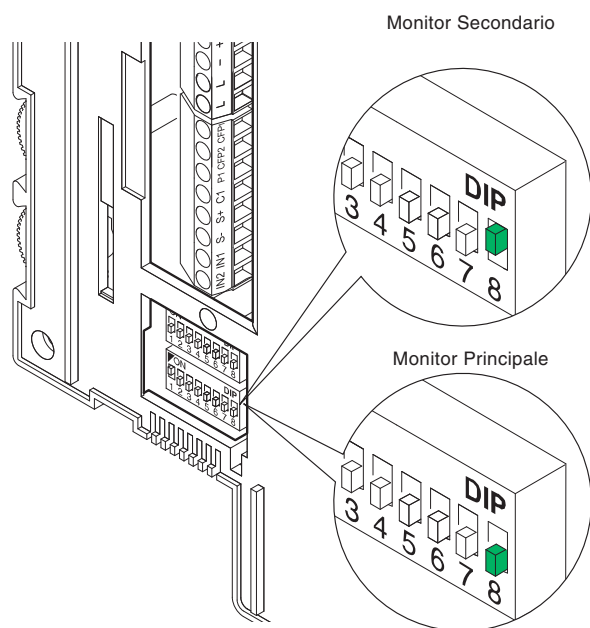

L'impostazione del DIP 8 di S2 definisce se la staffa in oggetto verrà gestita come principale (P) o secondaria (S).

Il posto esterno può gestire fino a un massimo di 4 videocitofoni o citofoni per pulsante di chiamata.

Nella configurazione classica del Magis Kit si possono avere al massimo 2 videocitofoni principali e 2 videocitofoni secondari per pulsante di chiamata tutti alimentati dallo stesso **Art. 1207**.

È possibile gestire fino a 3 videocitofoni principali all'interno della stessa unità familiare (cioè impostati sul medesimo codice utente). In questa particolare configurazione, i videocitofoni principali aggiuntivi dovranno essere alimentati dall'apposito **Art. 1212/B** (vedi variante MSK/HCA, MSK/IC pag. 132, 133).

Quando dal posto esterno si effettua una chiamata, il monitor che si accende è il videocitofono principale.

Gli eventuali monitor secondari della medesima unità familiare resteranno spenti.

Rispondendo alla chiamata del posto esterno da un videocitofono secondario, l'immagine viene automaticamente visualizzata sul monitor.

A questo punto il monitor del videocitofono principale si spegne e l'immagine compare sul monitor del videocitofono su cui viene premuto il pulsante 2 - autoaccensione/richiesta video.

Per visualizzare l'immagine senza attivare la fonica con il posto esterno, premere il pulsante 2 - autoaccensione/richiesta video.

Utilizzo kit in impianti con porta principale

Negli schemi MSK/EN/109IC, MSK/EN/110IC a pag. 128-131 viene mostrata una possibile configurazione di impianto che offre la possibilità di gestire fino a un massimo di 30 Magis Kit da parte di un Art. 4680C - Art. 4680KC* posto per esempio all'ingresso di un complesso residenziale. Utilizzando questi schemi di impianto è possibile chiamare uno dei Magis Kit dall'ingresso principale dotato di Art. 4680C - Art. 4680KC*. In questa configurazione è necessario programmare i pulsanti dell'Art. 4680KC a bordo dell'Art. 4879KC come descritto nella seguente procedura

ed i posti interni con il codice corrispondente, vedi tabella A pag. 9. Per maggiori informazioni sull'integrazione dei Magis Kit in impianti Simplebus e per la programmazione della porta principale (Art. 4680C - Art. 4680KC*) fare riferimento al catalogo Simplebus Color (n. 140), al manuale tecnico cod. 2G40000472.

*Limitazioni utilizzo Art. 4680KC

Il 4680KC gestisce le chiamate provenienti dai moduli pulsanti o digitali **SOLO** se comprese tra l'indirizzo 1 e l'indirizzo 10.

Programmazione pulsanti Art. 4680KC

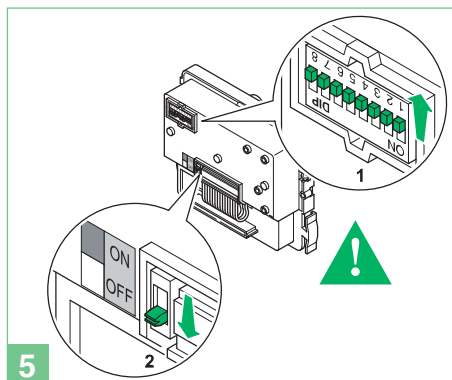
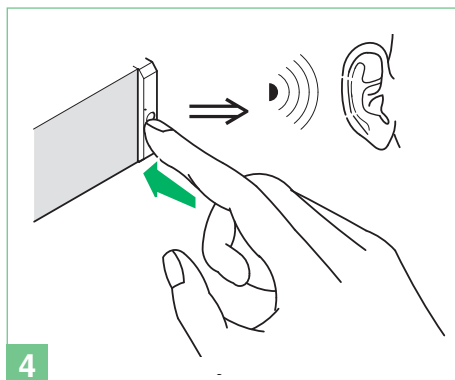
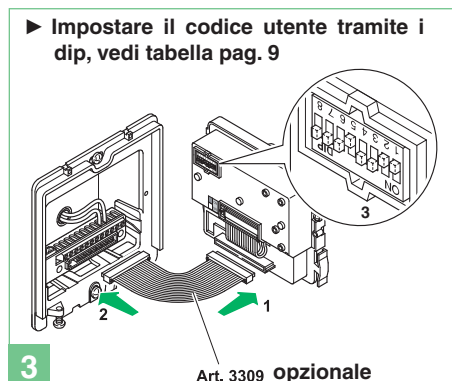
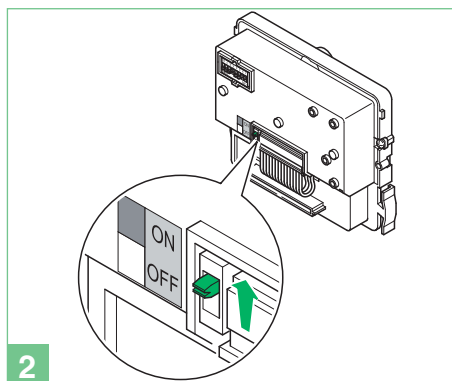
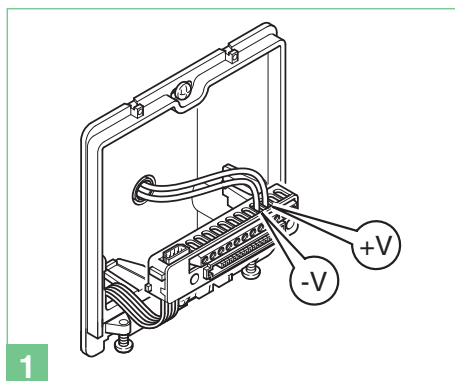

Configurazioni pulsanti di default

DIP S2								con Art. 6433, 6434			
DIP 1	DIP 2	DIP 3	DIP 4	P1	P2			P3	P4	P5	P6
0	0	0	0	CCS	AI			ACT	D	PAN	K
1	0	0	0	ACT	AI			INT	INTb	D	CCS
0	1	0	0	INT	AI			INTb	ACT	CCS	CCP
1	1	0	0	ACT	CCS			CCP	PAN	K	D
0	0	1	0	ACT	ACT	ACT		ACT	ACT	ACT	ACT
1	0	1	0	INT	ACT			CCS	CCP	INTb	PAN
0	1	1	0	AI	D			K	CCS	CCP	INTb
1	1	1	0	INTb	INT			AI	INT	PAN	D
0	0	0	1	CCS	PAN			D	AI	INT	INTb
1	0	0	1	K	CCS			PAN	CCP	AI	INT
0	1	0	1	CCP	K			PAN	ACT	INT	AI
1	1	0	1	PAN	CCP			CCS	K	ACT	D
0	0	1	1	D	INTb			INT	ACT	AI	CCS
1	0	1	1	INT	INT			INT	INT	INT	INT
0	1	1	1	NULL	NULL	NULL	NULL	NULL	NULL	NULL	NULL
1	1	1	1						PROG		

Legenda

	Apriporta	CCS	Chiamata a centralino	INTb	Intercomunicante bifamiliare - solo per KIT
	Fonica	K	Chiamata citofono guardiano	NULL	Nessuna funzione
ACT	Attuatore	D	Dottore	PROG	Funzioni programmate, vedi pag. 11-12-13-14. In questa impostazione dei dip i pulsanti gestiscono le funzioni programmate; i pulsanti NON programmati gestiscono le funzioni riferite alla riga 0000
AI	Autoaccensione	PAN	Panico		
CCP	Chiamata a centralino principale	INT	Intercomunicante programmabile generale o selettivo - di serie chiamata monofamiliare per KIT e Simplebus Top		

! Avvertenze generali programmazione pulsanti

Nel caso le configurazioni di default (vedi tabella pag. 11) non rispecchiano le necessità è possibile programmare diversamente i pulsanti secondo le procedure descritte di seguito.

Al termine posizionare i DIP 1-2-3-4 di S2 in combinazione 1111 (settaggio PROG nelle tabelle di configurazione pag. 11, 12, 13, 14). In questa

impostazione dei dip i pulsanti gestiscono le funzioni programmate; i pulsanti NON programmati gestiscono le funzioni riferite alla riga 0000 (vedi tabella pag. 11). Ripristinare su S1 l'impostazione del codice utente, vedi tabella A pag. 9.

Programmazioni pulsanti per attuatore generico o indirizzato

DIP S2								con Art. 6433, 6434				DIP S1
DIP 1	DIP 2	DIP 3	DIP 4	P1	P2			P3	P4	P5	P6	INDIRIZZO ON 1 2 3 4 5 6 7 8
0	0	0	0					ACT				
1	0	0	0	ACT								
0	1	0	0						ACT			
1	1	0	0	ACT								
0	0	1	0	ACT	ACT	ACT		ACT	ACT	ACT	ACT	
1	0	1	0		ACT							
0	1	1	0									
1	1	1	0									
0	0	0	1									
1	0	0	1									
0	1	0	1						ACT			
1	1	0	1							ACT		
0	0	1	1									
1	0	1	1						ACT			
0	1	1	1									
1	1	1	1									

Esempio:
 su monitor con codice utente 5 programmazione P1= attuatore generico, P2= attuatore indirizzato a codice 125.
 1. Posizionare DIP 5-6 di S2 in combinazione 01.
 » il led (verde) lampeggia
 2. Consultare la tabella pag. 12 e scegliere una combinazione in cui compare la funzione attuatore (ACT) per i pulsanti che si intendono programmare.
ES: per P1= attuatore generico impostare DIP 1-2-3-4 di S2 in combinazione 1000 o 1100 o 0010 (P1=ACT), impostare DIP di S1 in combinazione 11111111, passare al punto 3.
ES: per P2= attuatore indirizzato a codice 125 impostare DIP 1-2-3-4 di S2 in combinazione 0010 o 1010 (P2=ACT), impostare S1 con indirizzo 125. secondo **tabella C** pag. 14, passare al punto 3.

3. Premere e rilasciare il pulsante a cui si vuole associare la funzione.
 » il led (verde) si accende.
 » tono di conferma in cornetta.
 4. Per uscire dalla programmazione posizionare i DIP 5-6 di S2 in combinazione 00.
 » il led (verde) si spegne.
5. Al termine della programmazione posizionare i DIP 1-2-3-4 di S2 in combinazione 1111. Ripristinare su S1 l'impostazione del codice utente, vedi tabella C pag. 14.

Programmazioni per chiamata intercomunicante

Intercomunicante generale e selettivo **NON** sono compatibili sullo stesso montante.

Programmazione/cancellazione indirizzo intercomunicante (solo per intercomunicante selettivo)

S1	2)						S2	3)
	DIP 1	DIP 2	DIP 3	DIP 4	DIP 5	DIP 6		
Programmazione; impostare codice, TAB. B pag. 12	0	0	0	1	1	1	 ON 1 2 3 4 5 6 7 8 	
Cancellazione	1	1	1	1	1	1	 ON 1 2 3 4 5 6 7 8 	

Prendere nota dell'impostazione di S2, S1 e ripristinarla al termine della programmazione.

TAB. B Indirizzi intercomunicante selettivo

Codice / Code	Dip switch ON	S1	Codice / Code	Dip switch ON	S1	Codice / Code	Dip switch ON	S1
1	1		4	4		7	7	
2	2		5	5		8	8	
3	3		6	6				

È necessario impostare l'indirizzo intercomunicante a tutti i posti interni del montante.
 È possibile associare lo stesso indirizzo intercomunicante a un max di 3 posti interni.
 Per la chiamata di gruppo selezionare contemporaneamente i codici intercomunicanti desiderati (max 3).

Programmazioni pulsanti per chiamata intercomunicante

DIP S2				con Art. 6433, 6434				DIP S1					
DIP 1	DIP 2	DIP 3	DIP 4	P1	P2			P3	P4	P5	P6	INDIRIZZO 	
0	0	0	0										
1	0	0	0					INT	INTb				
0	1	0	0	INT				INTb					
1	1	0	0										
0	0	1	0										
1	0	1	0	INT						INTb			
0	1	1	0								INTb		
1	1	1	0	INTb	INT				INT				
0	0	0	1							INT	INTb		
1	0	0	1								INT		INT
0	1	0	1							INT			
1	1	0	1										
0	0	1	1		INTb			INT					
1	0	1	1	INT	INT			INT	INT	INT	INT		
0	1	1	1										
1	1	1	1										
PROG													

Esempio 1 - Intercomunicante selettivo

su monitor con codice utente 1 e indirizzo intercomunicante 1 programmazione P3= intercomunicante selettivo a indirizzo 2, P4= intercomunicante selettivo a indirizzo 3.

Esempio 2 - Intercomunicante KIT

(intercomunicante tra 2 indirizzi contigui nel range da 1 a 30 di cui il primo dispari):

su monitor con codice utente 1 programmazione P3= chiamata generale interna, P4= intercomunicante bifamiliare a indirizzo 2.

1. Posizionare DIP 5-6 di S2 in combinazione 01.

» *il led (verde) lampeggia.*

2. Consultare la tabella pag. 13 e scegliere una combinazione in cui compare la funzione intercomunicante (INT o INTb) per i pulsanti che si intendono programmare.

ES1: per P3= intercomunicante selettivo impostare DIP 1-2-3-4 di S2 in combinazione 1000 o 0011 o 1011 (P3=INT), impostare S1 con indirizzo 2 secondo **tabella B** pag. 12, passare al punto 3.

ES1: per P4= intercomunicante selettivo impostare DIP 1-2-3-4 di S2 in combinazione 1110 o 1011 (P4=INT), impostare S1 con indirizzo 3 secondo **tabella B** pag. 12, passare al punto 3.

ES2: per P3= chiamata generale interna e P4= intercomunicante bifamiliare impostare DIP 1-2- 3-4 di S2 in combinazione 1000 (P3=INT, P4=INTb), impostare S1 con codice utente 1 secondo **tabella A** pag. 9, passare al punto 3.

3. Premere e rilasciare il pulsante a cui si vuole associare la funzione.

» *il led (verde) si accende.*

» *tono di conferma in cornetta.*

4. Per uscire dalla programmazione posizionare i DIP 5-6 di S2 in combinazione 00.

» *il led (verde) si spegne.*

5. Al termine della programmazione posizionare i DIP 1-2-3-4 di S2 in combinazione 1111. Ripristinare su S1 l'impostazione del codice utente, vedi **tabella A** pag. 9.

Programmazioni pulsanti per altre funzioni

DIP S2				con Art. 6433, 6434				DIP S1					
DIP 1	DIP 2	DIP 3	DIP 4	P1	P2			P3	P4	P5	P6	PROG	
0	0	0	0	CCS	AI				D	PAN	K		
1	0	0	0		AI					D	CCS		
0	1	0	0		AI					CCS	CCP		
1	1	0	0		CCS			CCP	PAN	K	D		
0	0	1	0										
1	0	1	0					CCS	CCP		PAN		
0	1	1	0	AI	D			K	CCS	CCP			
1	1	1	0					AI		PAN	D		
0	0	0	1	CCS	PAN			D	AI				
1	0	0	1	K	CCS			PAN	CCP	AI			
0	1	0	1	CCP	K			PAN			AI		
1	1	0	1	PAN	CCP			CCS	K		D		
0	0	1	1	D						AI	CCS		
1	0	1	1										
0	1	1	1	NULL	NULL	NULL	NULL	NULL	NULL	NULL	NULL		NULL
PROG													

Legenda

	Apriporta	CCS	Chiamata a centralino	NULL	Nessuna funzione
	Fonica	K	Chiamata citofono guardiano	PROG	Funzioni programmate
AI	Autoaccensione	D	Dottore		
CCP	Chiamata a centralino principale	PAN	Panico		

Esempio:

su monitor con codice utente 5 programmazione P5= autoaccensione, P6= chiamata a centralino.

1. Posizionare DIP 5-6 di S2 in combinazione 01.

» *il led (verde) lampeggia.*

2. Consultare la tabella pag. 13 e scegliere una combinazione in cui compaiono le funzioni desiderate/necessarie per i pulsanti che si intendono programmare.

ES: per P5= autoaccensione P6= chiamata a centralino impostare DIP 1-2-3-4 di S2 in combinazione 0011 (P5=AI, P6=CCS).

3. Premere e rilasciare il pulsante a cui si vuole associare la funzione.

» *il led (verde) si accende.*

» *tono di conferma in cornetta.*

4. Per uscire dalla programmazione posizionare i DIP 5-6 di S2 in combinazione 00.

» *il led (verde) si spegne.*

5. Al termine della programmazione posizionare i DIP 1-2-3-4 di S2 in combinazione 1111.

TAB. C Indirizzi di montante

Code	Dip switch ON	Code	Dip switch ON	Code	Dip switch ON	Code	Dip switch ON	Code	Dip switch ON	Code	Dip switch ON	Code	Dip switch ON	Code	Dip switch ON
1	1	31	1,2,3,4,5	61	1,3,4,5,6	91	1,2,4,5,7	121	1,4,5,6,7	151	1,2,3,5,8	181	1,3,5,6,8	211	1,2,5,7,8
2	2	32	6	62	2,3,4,5,6	92	3,4,5,7	122	2,4,5,6,7	152	4,5,8	182	2,3,5,6,8	212	3,5,7,8
3	1,2	33	1,6	63	1,2,3,4,5,6	93	1,3,4,5,7	123	1,2,4,5,6,7	153	1,4,5,8	183	1,2,3,5,6,8	213	1,3,5,7,8
4	3	34	2,6	64	7	94	2,3,4,5,7	124	3,4,5,6,7	154	2,4,5,8	184	4,5,6,8	214	2,3,5,7,8
5	1,3	35	1,2,6	65	1,7	95	1,2,3,4,5,7	125	1,3,4,5,6,7	155	1,2,4,5,8	185	1,4,5,6,8	215	1,2,3,5,7,8
6	2,3	36	3,6	66	2,7	96	6,7	126	2,3,4,5,6,7	156	3,4,5,8	186	2,4,5,6,8	216	4,5,7,8
7	1,2,3	37	1,3,6	67	1,2,7	97	1,6,7	127	1,2,3,4,5,6,7	157	1,3,4,5,8	187	1,2,4,5,6,8	217	1,4,5,7,8
8	4	38	2,3,6	68	3,7	98	2,6,7	128	8	158	2,3,4,5,8	188	3,4,5,6,8	218	2,4,5,7,8
9	1,4	39	1,2,3,6	69	1,3,7	99	1,2,6,7	129	1,8	159	1,2,3,4,5,8	189	1,3,4,5,6,8	219	1,2,4,5,7,8
10	2,4	40	4,6	70	2,3,7	100	3,6,7	130	2,8	160	6,8	190	2,3,4,5,6,8	220	3,4,5,7,8
11	1,2,4	41	1,4,6	71	1,2,3,7	101	1,3,6,7	131	1,2,8	161	1,6,8	191	1,2,3,4,5,6,8	221	1,3,4,5,7,8
12	3,4	42	2,4,6	72	4,7	102	2,3,6,7	132	3,8	162	2,6,8	192	7,8	222	2,3,4,5,7,8
13	1,3,4	43	1,2,4,6	73	1,4,7	103	1,2,3,6,7	133	1,3,8	163	1,2,6,8	193	1,7,8	223	1,2,3,4,5,7,8
14	2,3,4	44	3,4,6	74	2,4,7	104	4,6,7	134	2,3,8	164	3,6,8	194	2,7,8	224	6,7,8
15	1,2,3,4	45	1,3,4,6	75	1,2,4,7	105	1,4,6,7	135	1,2,3,8	165	1,3,6,8	195	1,2,7,8	225	1,6,7,8
16	5	46	2,3,4,6	76	3,4,7	106	2,4,6,7	136	4,8	166	2,3,6,8	196	3,7,8	226	2,6,7,8
17	1,5	47	1,2,3,4,6	77	1,3,4,7	107	1,2,4,6,7	137	1,4,8	167	1,2,3,6,8	197	1,3,7,8	227	1,2,6,7,8
18	2,5	48	5,6	78	2,3,4,7	108	3,4,6,7	138	2,4,8	168	4,6,8	198	2,3,7,8	228	3,6,7,8
19	1,2,5	49	1,5,6	79	1,2,3,4,7	109	1,3,4,6,7	139	1,2,4,8	169	1,4,6,8	199	1,2,3,7,8	229	1,3,6,7,8
20	3,5	50	2,5,6	80	5,7	110	2,3,4,6,7	140	3,4,8	170	2,4,6,8	200	4,7,8	230	2,3,6,7,8
21	1,3,5	51	1,2,5,6	81	1,5,7	111	1,2,3,4,6,7	141	1,3,4,8	171	1,2,4,6,8	201	1,4,7,8	231	1,2,3,6,7,8
22	2,3,5	52	3,5,6	82	2,5,7	112	5,6,7	142	2,3,4,8	172	3,4,6,8	202	2,4,7,8	232	4,6,7,8
23	1,2,3,5	53	1,3,5,6	83	1,2,5,7	113	1,5,6,7	143	1,2,3,4,8	173	1,3,4,6,8	203	1,2,4,7,8	233	1,4,6,7,8
24	4,5	54	2,3,5,6	84	3,5,7	114	2,5,6,7	144	5,8	174	2,3,4,6,8	204	3,4,7,8	234	2,4,6,7,8
25	1,4,5	55	1,2,3,5,6	85	1,3,5,7	115	1,2,5,6,7	145	1,5,8	175	1,2,3,4,6,8	205	1,3,4,7,8	235	1,2,4,6,7,8
26	2,4,5	56	4,5,6	86	2,3,5,7	116	3,5,6,7	146	2,5,8	176	5,6,8	206	2,3,4,7,8	236	3,4,6,7,8
27	1,2,4,5	57	1,4,5,6	87	1,2,3,5,7	117	1,3,5,6,7	147	1,2,5,8	177	1,5,6,8	207	1,2,3,4,7,8	237	1,3,4,6,7,8
28	3,4,5	58	2,4,5,6	88	4,5,7	118	2,3,5,6,7	148	3,5,8	178	2,5,6,8	208	5,7,8	238	2,3,4,6,7,8
29	1,3,4,5	59	1,2,4,5,6	89	1,4,5,7	119	1,2,3,5,6,7	149	1,3,5,8	179	1,2,5,6,8	209	1,5,7,8	239	1,2,3,4,6,7,8
30	2,3,4,5	60	3,4,5,6	90	2,4,5,7	120	4,5,6,7	150	2,3,5,8	180	3,5,6,8	210	2,5,7,8	*240	5,6,7,8

*NOTA: il codice 240 è riservato per il centralino di portineria

Reset programmazione

1)	2)						3)		4)	
S1	DIP 1	DIP 2	DIP 3	DIP 4	DIP 5	DIP 6	S2	S1/S2/LED1		
	1	1	1	1	1	1				
Configurazioni di fabbrica: <ul style="list-style-type: none"> • Funzioni pulsanti in funzione della combinazione DIP 1-2-3-4 di S2; • Indirizzo intercomunicante assente; • Funzione range e indirizzi min e max assenti; • Reset suonerie; • Ingresso IN 1 ⇒ LED (default). 										

Eeguire le operazioni da 1 a 4

Programmazione range/suonerie

		! 2)							3)		4)
! 1)		DIP 1	DIP 2	DIP 3	DIP 4	DIP 5	DIP 6	S2		S1/S2/LED1	
Indirizzo minimo range	impostare codice, TAB. C pag. 14	0	0	0	0	1	0				
Indirizzo massimo range											
Ablitazione range											
Disabilitazione range											
Selezione suoneria polifonica		0	1	0	1	1	0				
Selezione suoneria toni (default)		0	1	0	1	1	0				

! Prendere nota dell'impostazione di S2, S1 e ripristinarla al termine della programmazione

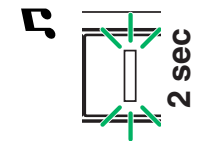

Eseguire le operazioni da 1 a 4														
		1)				2)				3)		4)		
Programmazione ingresso IN1 per segnalazione led/allarme/apriporta/attuatore		S1		DIP 1	DIP 2	DIP 3	DIP 4	DIP 5	DIP 6	S2		S1/S2/LED1		
Ingresso IN 1 ⇒ LED (default), vedi pag. 138														
Ingresso IN 1 ⇒ ALLARME, vedi pag. 138				0	0	0	1	1	0					
Ingresso IN 1 ⇒ APPRIORTA, vedi pag. 138														
Ingresso IN 1 ⇒ ATTUATORE INDIRIZZATO, vedi pag. 138	impostare codice, TAB. C pag. 14			0	0	1	0	1	0					
Ingresso IN 1 ⇒ ATTUATORE GENERICO, vedi pag. 138														

Prendere nota dell'impostazione di S2, S1 e ripristinarla al termine della programmazione

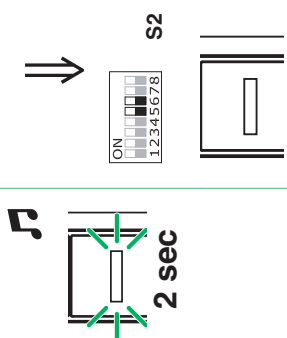

Programmazione diretta chiamata intercomunicante

Consente la programmazione delle chiamate intercomunicanti direttamente dai posti interni.

✓ Necessita di 2 operatori.

Fase 1: ingresso in programmazione

Operatore 1 e Operatore 2 eseguono le seguenti operazioni su 2 posti interni:

1. Impostare dip 1-2-3-4 di S2 in combinazione 1111.
2. Sollevare la cornetta.
3. Premere il tasto 1 e 2 per 3 sec.
»Il posto interno emette 1 tono.
»Il led verde lampeggia.
»Il posto interno entra in fonica.
»A questo punto i 2 operatori sono in comunicazione tra di loro.

Fase 2: programmazione chiamata intercomunicante

Operatore 1:

- ▶ Preme il pulsante che vuole programmare per chiamare l'operatore 2 (es. 2).
»Il posto interno dell'operatore 1 emette un tono di conferma.

Operatore 2:

- ▶ Preme il pulsante che vuole programmare per chiamare l'operatore 1 (es. 1).
»Il posto interno dell'operatore 2 emette un tono di conferma.

Operatore 1/Operatore 2:

- ▶ Agganciare la cornetta.
»Il posto interno emette 1 tono.
»La programmazione dei 2 posti interni è così ultimata.
Per programmare un ulteriore posto interno passare alla FASE 3.



Fase 3: programmazione di altri posti interni

Operatore 1/Operatore 2:

1. Raggiunta la nuova postazione esegue la fase 1 per entrare in comunicazione.
2. Ripetere la fase 2.

N.B. Nel caso in cui si riceve una chiamata durante la programmazione è necessario rispondere alla chiamata e successivamente riprendere la fase di programmazione.

Variazione suonerie monitor

1. Tenere premuto il pulsante  fino a che non verrà emesso un suono di conferma (l'operazione è possibile solo con l'impianto in situazione di riposo; in caso contrario il led di segnalazione lampeggerà per avvisare l'utente).
2. Premere e rilasciare il pulsante  :
1 volta (viene emesso un tono di conferma) per modificare la suoneria di chiamata da posto esterno.
2 volte (vengono emessi 2 toni di conferma) per modificare la suoneria di chiamata da centralino.
3 volte (vengono emessi 3 toni di conferma) per modificare la suoneria di chiamata intercomunicante da posto interno.
4 volte (vengono emessi 4 toni di conferma) per modificare la suoneria della chiamata da piano.
Ulteriori pressioni del pulsante  ripetono la sequenza appena descritta.
3. Premere e rilasciare il pulsante 1 per scorrere in sequenza le varie suonerie disponibili.
4. Premere il pulsante 2 per confermare la scelta dell'ultima suoneria ascoltata e per uscire (in qualunque momento) dalla modalità di variazione suoneria monitor. All'uscita dalla modalità di variazione suoneria monitor verrà emesso un suono di conferma.

Programmazioni speciali Art. 4680KC

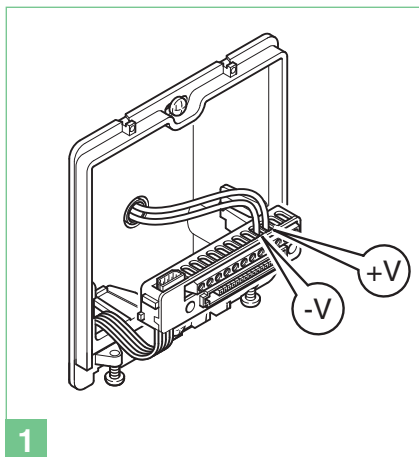

1

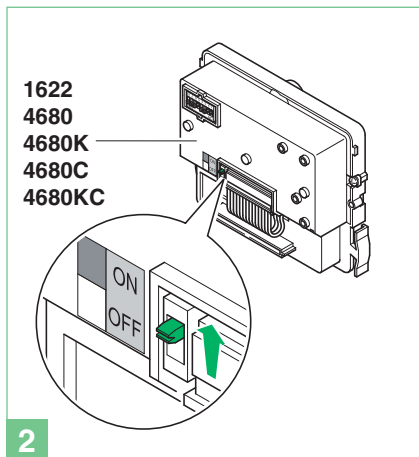

2

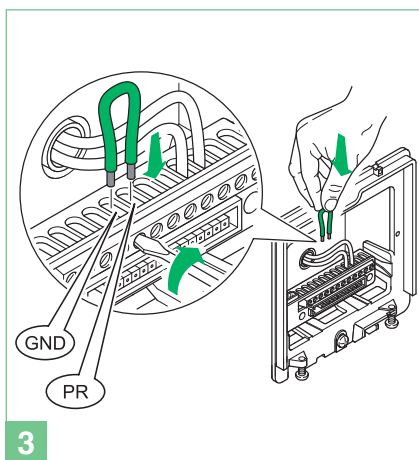

3

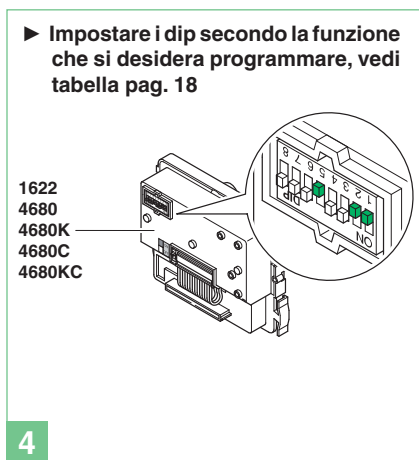

4

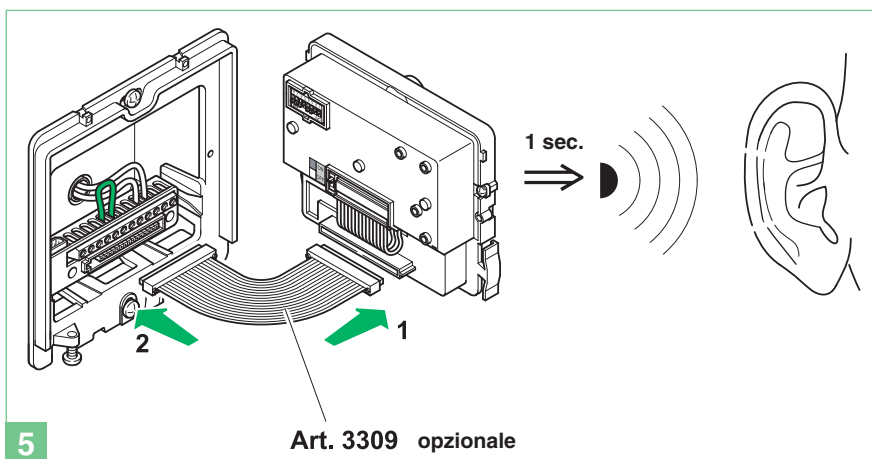

5

Art. 3309 opzionale

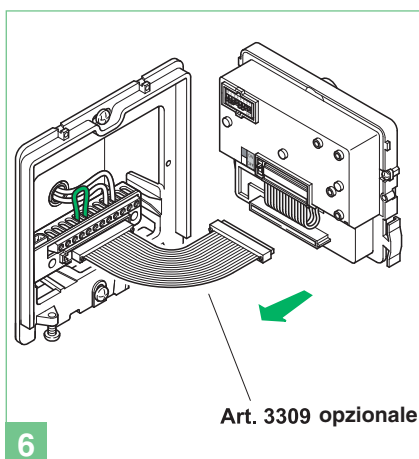

6

Art. 3309 opzionale

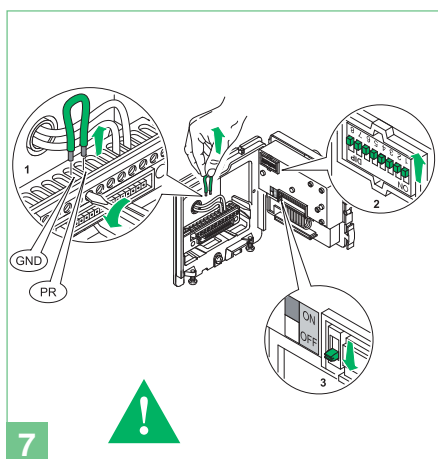

7

Codice	Dip switch ON	
Resistenza di antiappannamento		
213	1,3,5,7,8	OFF (default)
212	3,5,7,8	ON

Messaggi audio-visivi		
210	2,5,7,8	solo messaggi visivi
211	1,2,5,7,8	Svedese
214	2,3,5,7,8	OFF (default)
215	1,2,3,5,7,8	Italiano
216	4,5,7,8	Francese
217	1,4,5,7,8	Spagnolo
218	2,4,5,7,8	Olandese
219	1,2,4,5,7,8	Greco
220	3,4,5,7,8	Inglese
221	1,3,4,5,7,8	Tedesco
222	2,3,4,5,7,8	Portoghese

Serratura		
223	1,2,3,4,5,7,8	Comando serratura su SE in AC (default)
224	6,7,8	Comando serratura su SE in AC potenziata
225	1,6,7,8	Comando serratura su SE in DC

245	1,3,5,6,7,8	Tempo serratura: 2 sec + tono disattivo (default)
246	2,3,5,6,7,8	Tempo serratura: 4 sec
247	1,2,3,5,6,7,8	Tempo serratura: 8 sec

248	4,5,6,7,8	Tono conferma serratura: attivo
251	1,2,4,5,6,7,8	Relè C.NC.NO in parallelo a SE (default)

252	3,4,5,6,7,8	Apriporta sempre attivo (default)
253	1,3,4,5,6,7,8	Apriporta attivo solo per utente chiamato

Gestione comando attuatore		
N.B. sull'impianto non deve essere presente l'Art. 1256 in modalità attuatore generico.		
229	1,3,6,7,8	Attivazione relè C.NC.NO su comando attuatore: 2 sec
230	2,3,6,7,8	Attivazione relè C.NC.NO su comando attuatore: 4 sec
231	1,2,3,6,7,8	Attivazione relè C.NC.NO su comando attuatore: 8 sec

228	3,6,7,8	Comando attuatore su linea seriale S: disattivo (default)
227	1,2,6,7,8	Comando attuatore su linea seriale S: attivo

Funzioni impianto		
232	4,6,7,8	Tempo di attesa risposta: 60 sec (default)
233	1,4,6,7,8	Tempo di attesa risposta: 120 sec
234	2,4,6,7,8	Tempo di attesa risposta: 30 sec

235	1,2,4,6,7,8	Tempo di conversazione: 90 sec (default)
236	3,4,6,7,8	Tempo di conversazione: 180 sec

237	1,3,4,6,7,8	Autoaccensione: attiva (default)
238	2,3,4,6,7,8	Autoaccensione: disattiva

239	1,2,3,4,6,7,8	Tono conferma su chiamata utente: attivo (default)
240	5,6,7,8	Tono conferma su chiamata utente: disattivo

243	1,2,5,6,7,8	Tempo di attesa reset: 10 sec (default)
244	3,5,6,7,8	Tempo di attesa reset: 1 sec
208	5,7,8	Reset dopo apriporta in fonica: attivo (default)
209	1,5,7,8	Reset dopo apriporta in fonica: disattivo
249	1,4,5,6,7,8	Invio chiamata: singola (default)
250	2,4,5,6,7,8	Invio chiamata: tripla

254	2,3,4,5,6,7,8	Ripristino default
-----	---------------	---------------------------

Warning:

- Install the equipment by carefully following the instructions given by the manufacturer and in compliance with the standards in force.
- All the equipment must only be used for the purpose it was designed for. **Comelit Group S.p.A.** declines any responsibility for improper use of the apparatus, for modifications made by third parties for any reason or purpose, and for the use of accessories and materials which are not originals.
- All the products comply with the requirements of Directive 2006/95/EC (which replaced Directive 73/23/EEC and subsequent amendments), as certified by the **CE** mark they carry.
- Do not route the riser wires in proximity to power supply cables (230/400V).
- Do not insert objects or pour liquids into the device.
- Installation, mounting and assistance procedures for electrical devices must only be performed by specialised electricians.
- Cut off the power supply before carrying out any maintenance work.
- Connect the module-holder frame to earth (see Fig.).
- Do not press and hold the audio hook while the handset is lifted.
- The camera must not be installed opposite bright light sources, or in places where the filmed subject is against the light. To resolve this problem, we recommend modifying the installation height of the camera, which is usually 160 - 165 cm, to a height of 180 cm and pointing the lens downward so as to improve filming quality.
- Cameras with colour CCD sensor have poorer sensitivity in low light conditions than black/white cameras. We therefore recommend, in dimly lit environments, that an additional light source is installed.

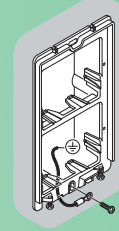

General information	20
External unit	20
Art. 4879KC	20
Art. 1207	20
Installing the external unit	20
Inserting nameplates	21
Internal units	22
Mounting the Magis internal unit	22
Removing the monitor	22
Art. 6402E	23
Description of monitor	23
Art. 2608	24
Installing door-entry phone Art. 2608	24
General installation and operating instructions	25
Operating distances table	25
Operation	25
Description of button functions and settings	26
Settings for monitor Art. 6402E and Style door-entry phone	26
TAB. A Riser addresses	26
Description of functions	26
Additional main or secondary monitors	27
Using the kit in systems with a main entrance	27
Programming buttons on Art. 4680KC	28
Default button settings	28
General button programming warnings	28
Programming buttons for generic or coded actuator	29
Programming for intercom call	29
Programming/deleting intercom address (selective intercom only)	29
TAB. B Selective intercom addresses	29
Programming buttons for intercom call	30
Programming buttons for other functions	30
TAB.C Riser addresses	31
Programming reset	31
Programming range/ringtones	32
Programming input IN1 for LED/alarm/lock-release/actuator indication	33
Direct programming of intercom call	34
Monitor ringtone selection	34
Special programming - Art. 4680KC	35
Wiring diagrams	
MSK/018IC Basic diagram for two-family kits Art. 8172IMC with cascade connection. Switching on/voltage check with system in standby.....	121
MSK/013IBC Basic diagram for two-family kits Art. 8172IMC with branch connection	122
MSK/014IBC Diagram for two-family kits Art. 8172IMC extended with a second Art. 4879KC. Branch connection.....	123
MSK/014IAC Diagram for two-family kits Art. 8172IMC extended with a second Art. 4879KC. Cascade connection.....	124
MSK/018I/AC Diagram for two-family kit with additional power supply unit Art. 1595	125
MSK/019IC Use of remote camera module Art. 1259C	126
PXK/EC Connecting actuator relay Art. 1256.....	127
MSK/EN/109IC Diagram for connecting 2 to 9 Magis Kits to main entrance panel using Art. 4834/9.....	128
MSK/EN/110IC Diagram for connecting 30 Magis Kits (maximum) to the main entrance panel. Cascade connection of Magis using Art. 1424.	130
SB2/AAR Connection of video amplifier Art. 4833C.....	132
MSK/HCA Addition of a main monitor in parallel. Cascade connection	132
MSK/IC Addition of a main monitor in parallel. Branch connection	133
MSK/A20S Cascade connection of third main monitor with local power supply	133
MSK/A23S Branch connection of 2 main monitors and 2 secondary monitors with the same user code.....	134
MSK/A21S Cascade connection of 2 main monitors and 1 secondary monitor with the same user code.....	134

MSK/AAE Connection of additional door-entry phones with branch connection from monitor 135
 MSK/AAD Connection of additional door-entry phones with cascade connection from monitor..... 135
 MSK/FC Addition of a parallel door-entry phone, with branch connection from riser..... 136
 SB/X3 Use for various purposes of button P1 (Art. 2608) 136
 SB2V/AAK Connection of call repetition devices (Art. 1229 or Art. 1122/A) 137
 Floor door call connection variant 137
 Using IN1 input for LED/ALARM/LOCK-RELEASE/ACTUATOR indication. Activation on closure towards CFP2..... 138
 Using IN1 input for LED/ALARM/LOCK-RELEASE/ACTUATOR indication. Activation in the presence of voltage in relation to IN2 138
 SB2/AAM2 Use for various purposes of button P1 139
 PXX/RTNP Using the external unit relay on lock-release or actuator control (see special programming, page 35: actuator control management) 139
 PXX/SNP Variant with security door lock and additional power supply..... 140
 Using the RC network for door lock filter on relay contacts..... 140
 PXX/DO Door open indication use variant. 141

General information

The Two-Family door entry monitor kits Art. 8172IMC can be used in residential or service sector buildings where effective access control and simple installation procedures are required.

In fact, it only requires 2 wires between the external unit and the internal monitor/s to activate the system (calls, audio, video self-ignition), plus 2 wires to power the external unit and the electric lock and 2 wires to power the door entry monitor internal unit.

A wide range of accessories is also available to deal with the needs of any type of system; in fact, in addition to interesting standard type accessories, the system can also be extended by adding door entry monitors and/or door-entry phones and/or external units. This makes it possible to reach a maximum of 2 external units with 8 internal units including door-entry phones and door entry monitors for two-family configuration.

By means of appropriate settings single-family intercom communications (i.e. between users with the same user code) are possible using both door entry monitors and door-entry phones.

Several kits can be connected to a Simplebus main entrance panel and/or a switchboard Art. 1998A.

Loudspeaker volume control.

Flush-mounted box dimensions: 118x118x45 mm.

The buttons on Art. 4879KC are factory set to call addresses 1 (left-hand button) and 2 (right-hand button).

External unit dimensions: 112x89.5x40 mm.

Description of terminal block

LL monitor connection (video, call, audio, lock-release).

V+ V- external unit power supply.

RTE request to exit input.

DO door open indication input.

PR programming terminal.

GND negative terminal to be used in programming stage.

NO NC COM 10 A relay contacts.

SE electric lock connection.

External unit

Art. 4879KC

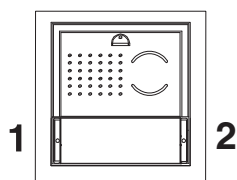

Art. 4879KC

Art. 1207

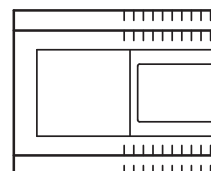

Technical characteristics

The transformer provides 2 outputs: one to power the external unit and the electric lock and the other to power the monitor.

Dimensions: 105x85x85 mm (6 DIN modules).

Protected from short-circuits and overloads.

Technical characteristics

Connection to monitor with 2 wires for audio, video, lock-release and call plus 2 wires for power supply from Art. 1207.

High sensitivity, adjustable camera with 1/3" CCD sensor.

Nameplates with LED lighting (options: blue, white or off).

Description of terminal block

L $\frac{1}{2}$ N mains voltage input 110-240 VAC

+22V 0V monitor power supply DC output

+33V 0V DC output for external unit and electric lock

Installing the external unit

► Leave the system protection device in position

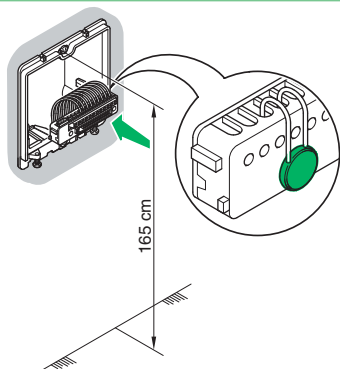

1

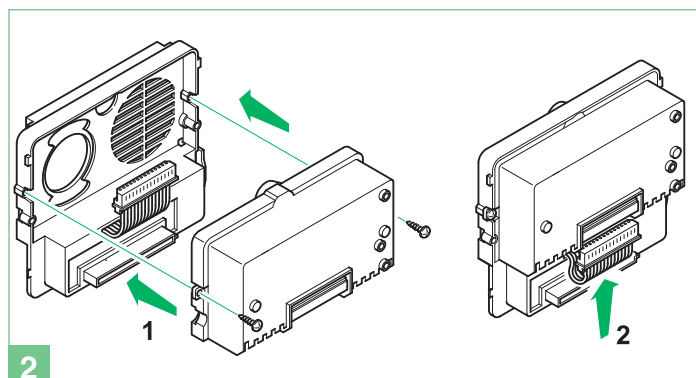

2

► Nameplate LED lighting selection

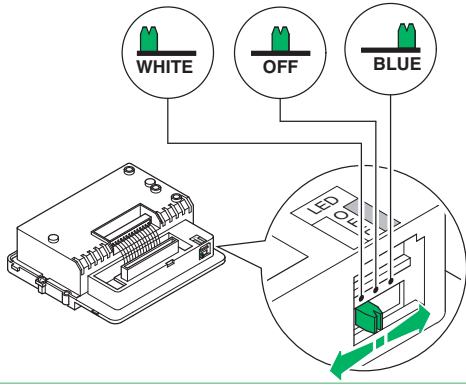

3

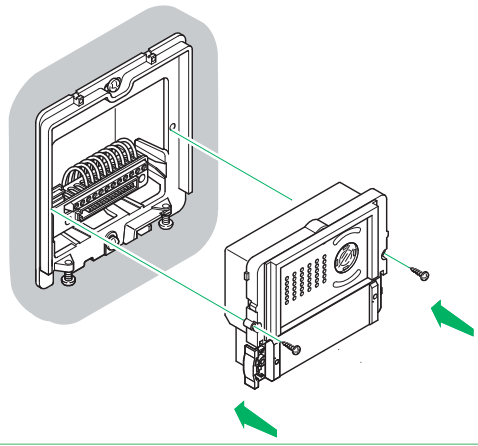

4

Alternative microphone position

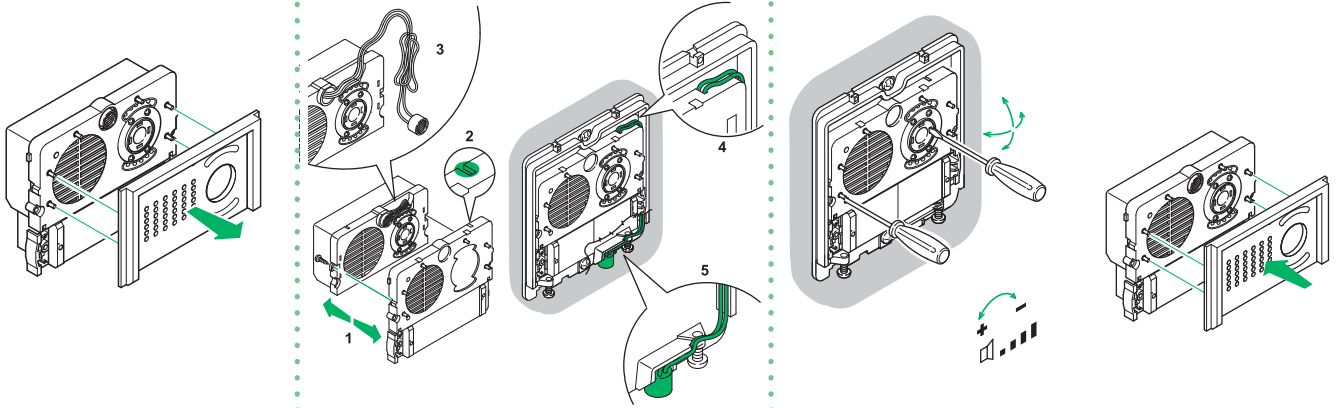

4A

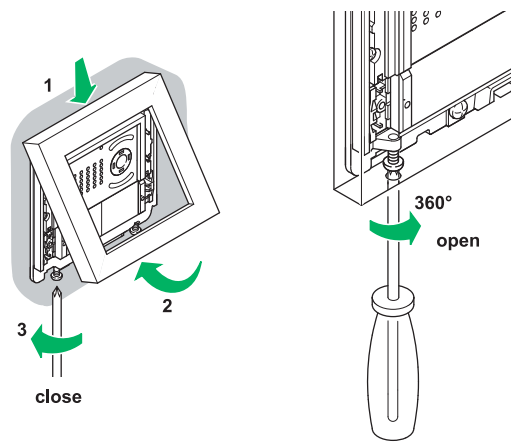

5

Inserting nameplates

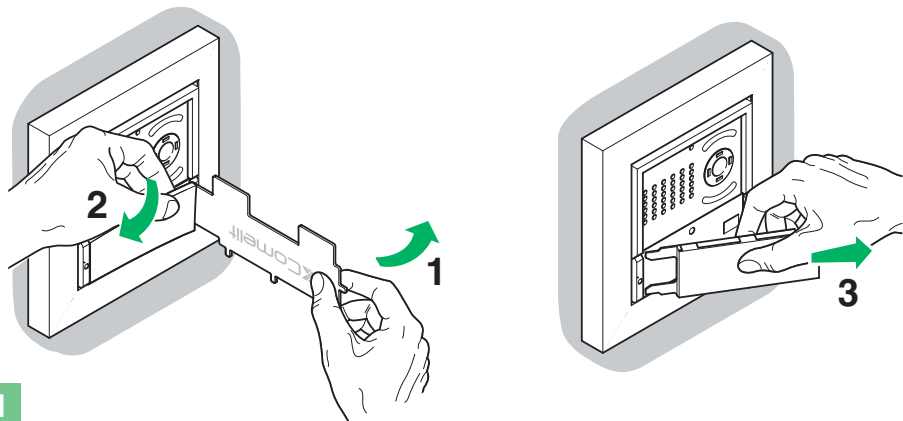

1

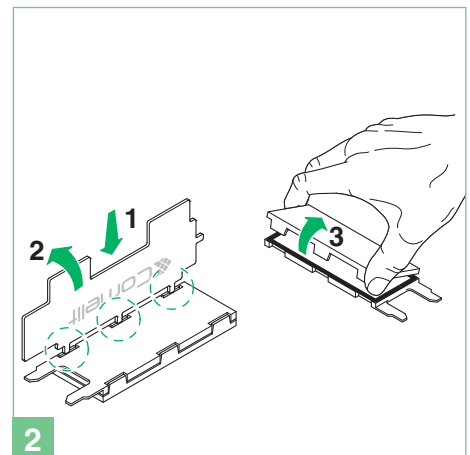

2

► Centre the label to prevent infiltration

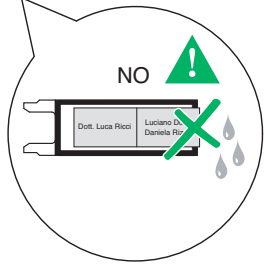

3

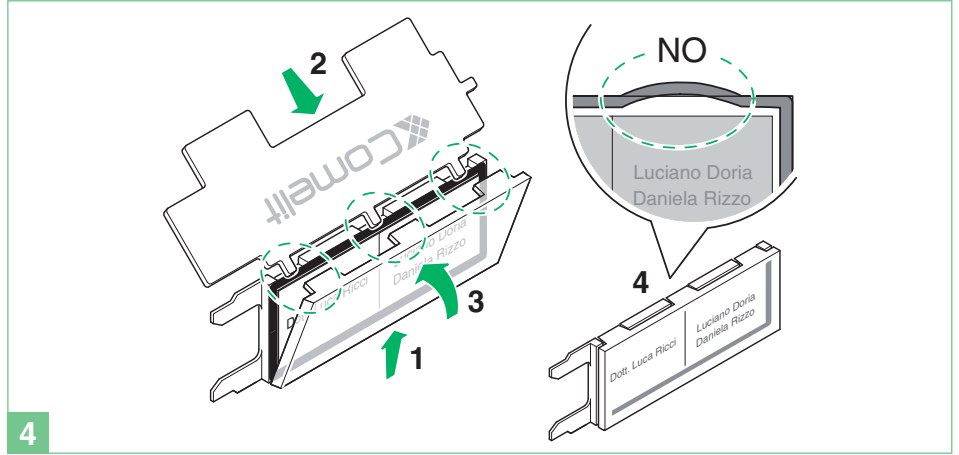

4

Internal units

Mounting the Magis internal unit

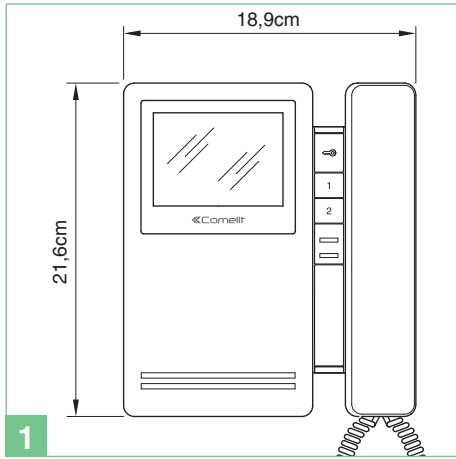

1

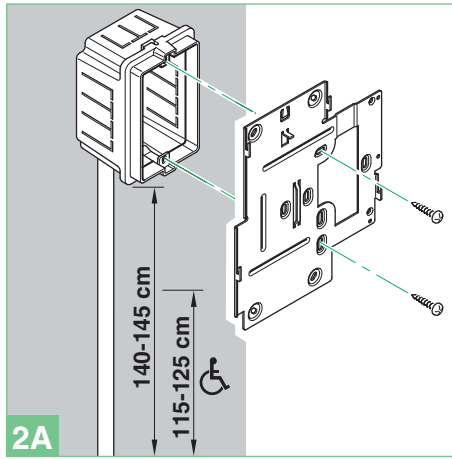

2A

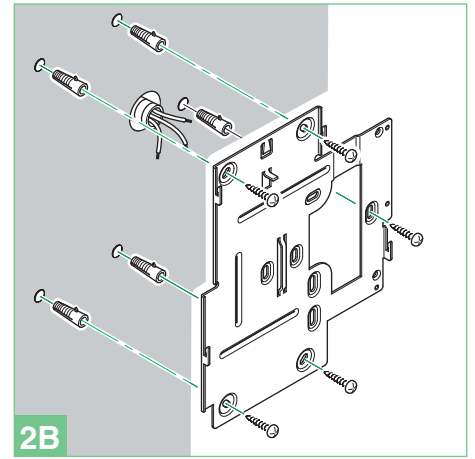

2B

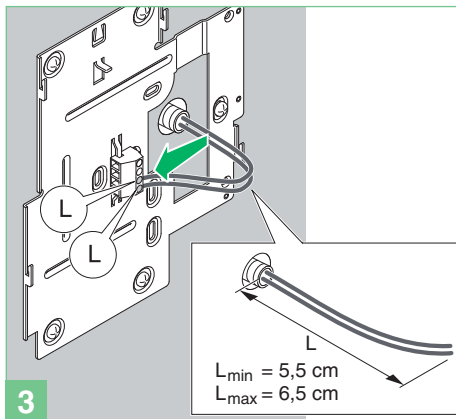

3

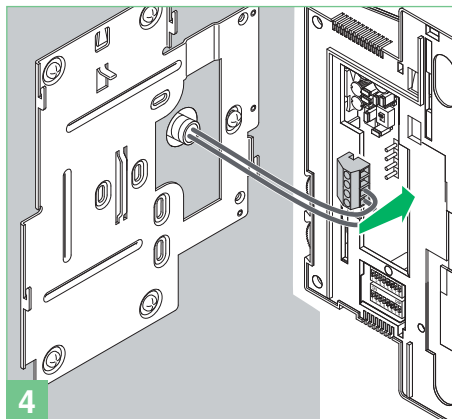

4

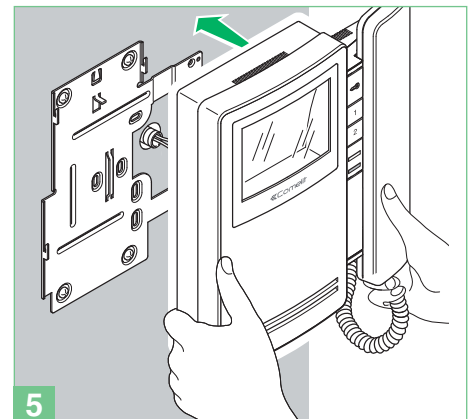

5

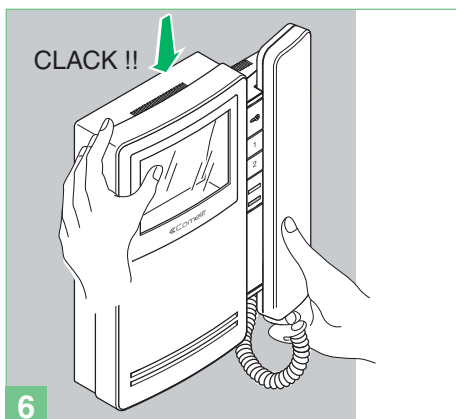

6

Removing the monitor

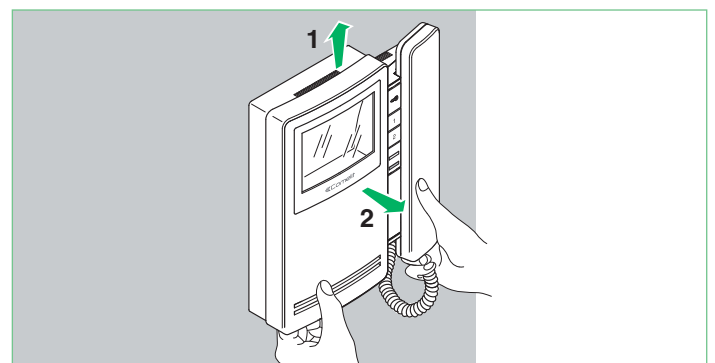

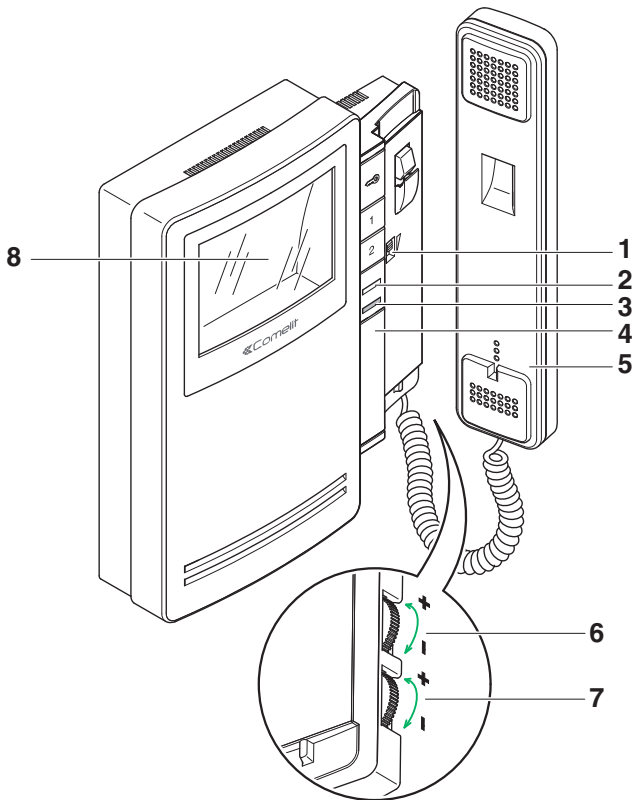

Monitor description:

- 1 Call volume adjustment / Privacy function selector (Privacy service means exclusion of the call from the external unit and from intercommunicating interphones or video doorphones; activation of the Privacy function is shown by a red indicator appearing on the left-hand side of the selector).
- 2 Indicator LED for system busy/Doctor function enabled/door open
- 3 Red indicator - Privacy enabled.
- 4 Space for additional button installation with accessory Art. 6333, Art. 6434.
- 5 Monitor handset (lift handset to start communication).
- 6 Colour intensity adjustment knob.
▶ To increase the value, turn anticlockwise.
- 7 Brightness control knob.
▶ To increase the value, turn anticlockwise.
- 8 3,5" colour screen.

Description of buttons:

- Ⓜ Door-opening pushbutton.
- 1 Key 1 general actuator (programmable).
- 2 Self-ignition key 2 (programmable).

Description of monitor

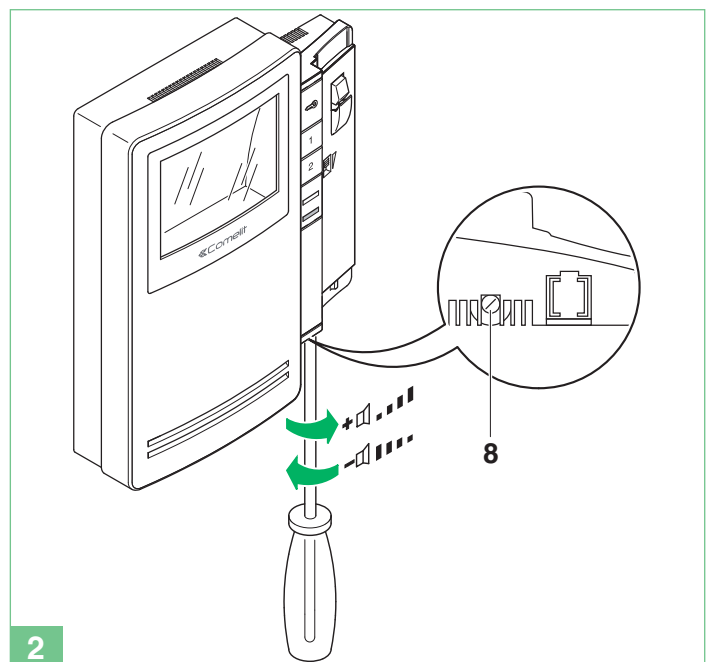
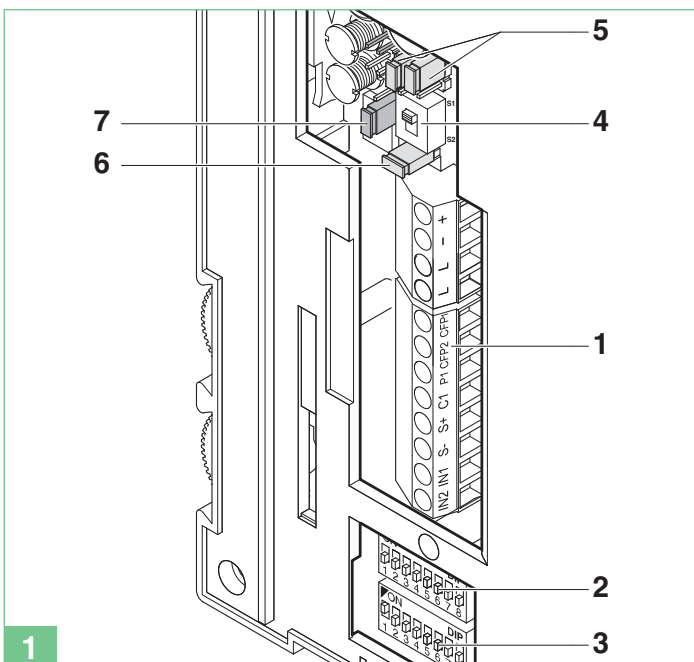

- 1 Terminal block for system connection:
+ - Power supply terminals.
L L Bus line connection terminals.
CFP1 CFP2 Floor door call input.
P1 C1 Button 1 terminals for various services.
To have a C.NO. contact (24 V-100 mA max.), move jumpers CV3 and CV4. to position B.
S+ S- Terminals for call repetition device.
IN1 IN2 LED input (programmable).
- 2 S1 User code programming microswitches.
- 3 S2 Microswitches for programming buttons and functions (marked with a red corner):
DIP 1-2-3-4 for button function programming.
DIP 5-6 access to programming.

- DIP 7 for power supply voltage management (see diagrams and variants on page 121), default = OFF .
- DIP 8:
ON secondary bracket.
OFF main bracket (default).
- 4 SW3 Selector for Simplebus 1 (S1- default) or Simplebus 2 (S2) modes.
- 5 CV3 CV4 Jumper for freeing button 1 (C.NO. contact 24 V-100 mA max.).
A button 1 general actuator (default) or programmable.
B button 1 for various uses.
- 6 CV5 Jumper for video closure.
- 7 CV6 selector for using input IN 1 (see page 138).
- 8 Loudspeaker volume adjustment (for setting intercom audio only).

Art. 2608

Cannot be used for the intercom function.
The door-entry phone should always be mounted using Art. 1214/2C as illustrated in connection diagram MSK/FC a pag. 136.

- 1 Privacy function indicator.
- 2 3-position ringtone/Privacy service selector:
High position: Maximum ringtone volume.
Middle position: Medium ringtone volume.
Low position: Privacy function activation.
Privacy service means exclusion of the call ringtone from the external unit and switchboard; activation of the Privacy function is signalled by a red indicator appearing at the top right-hand side).
- 3 Trimmer for adjusting the microphone volume.
- 4 User code programming microswitches.
- 5 System connection terminals:
L L Bus line connection.
CFP CFP Floor door call input.
P1 C1 Button P1 terminals for various purposes (contact C. NO 24 V - 100 mA max.) (remove CV1 and CV2, see variant SB/X3 pag. 136).
S+ S- Terminals for call repetition device.
- 6 CV1 CV2 Jumpers to be removed in order to have potential-free C. NO contact on button P1.
- 7A/7B JP1 Jumpers for selecting the switchboard call (position C) / generic actuator (position A) function of button P1.

Description of buttons:

- Key button.
- P1 Button P1 for switchboard call / generic actuator / button for various purposes present on terminal block (P1 C1).

Clean using a damp cloth. Do not use alcohol or other aggressive products.

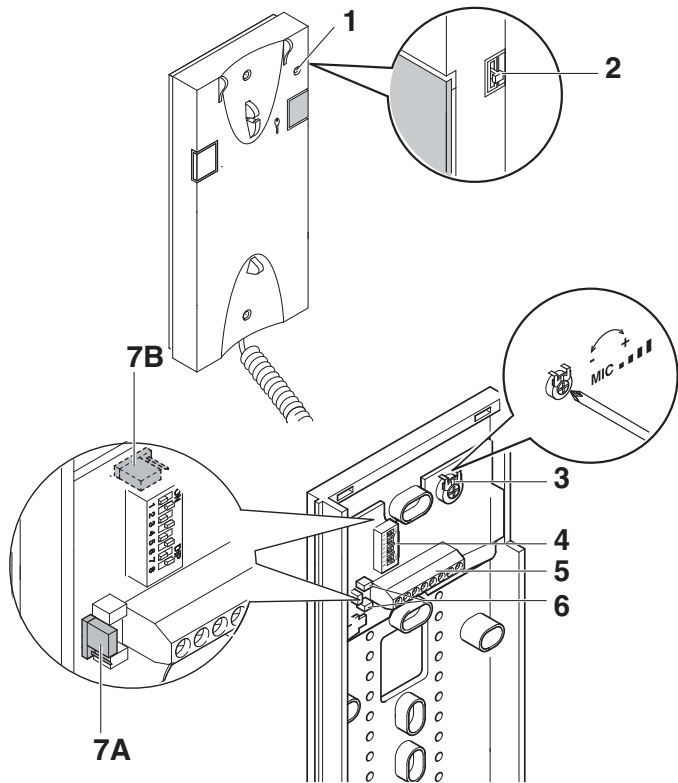



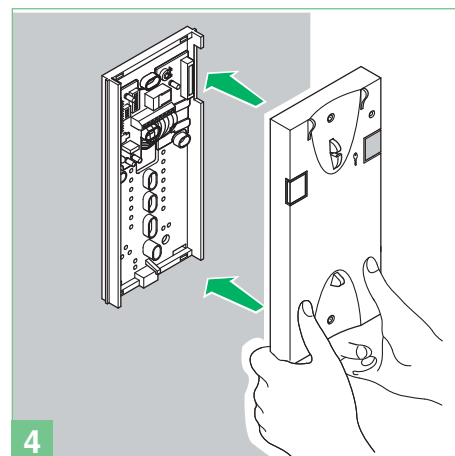
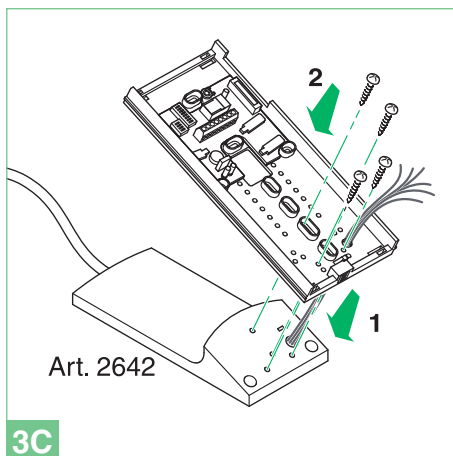
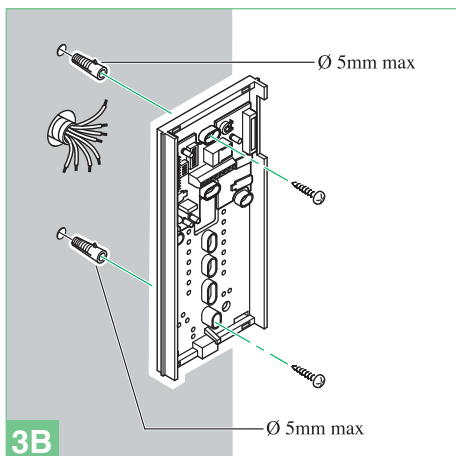
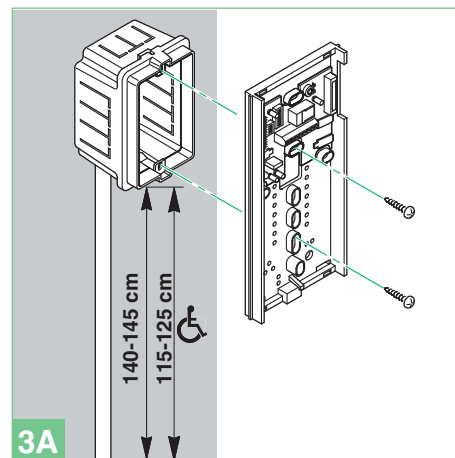
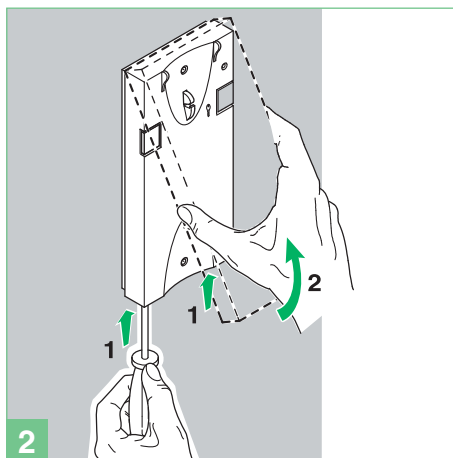
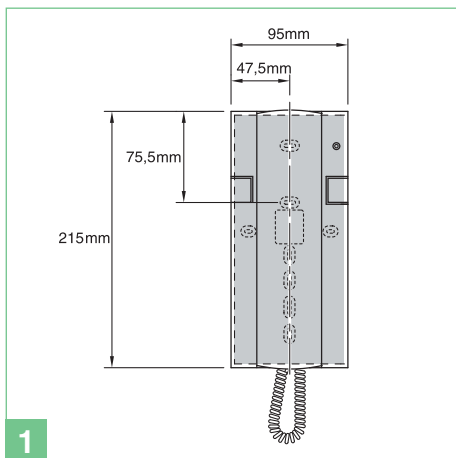















Installing door-entry phone Art. 2608



General installation and operating instructions

The maximum total distance between the external unit and the furthest monitor is 400 m (with amplifier Art. 4833C).
 The total number of internal units with the same user code added to the number of call repetition devices connected to these internal units cannot exceed 4.
 Connect only one call repetition device for each internal unit.
 The MAX. cable length between the internal unit and call repetition device is 20 m. A shielded cable should be used for the connection and should not run close to heavy inductive loads or power supply cables (230 V / 400 V).

Operating distances table

		A/G MAX	B/E MAX	C MAX	D MAX	F MAX	Art. 1216
Comelit Art. 4577 1 mm ² (Ø 1,2 mm AWG 17) 		50 m (165 feet)	50 m (165 feet)	200 m (655 feet)	100 m (330 feet)	150 m (495 feet)	
Comelit Art. 4576-4578	0,5 mm ² (Ø 0,8 mm AWG 20) bus 		25 m (85 feet)	200 m (655 feet)	100 m (330 feet)	150 m (495 feet)	
	1,5 mm ² (Ø 1,4 mm AWG 15) power 	75 m (245 feet)	100 m (330 feet)				
UTP5 cat. 5 0,2 mm ² (Ø 0,5 mm AWG 24) 				190 m (625feet)	60 m (195 feet)	150 m (495 feet)	
0,28 mm ² (Ø 0,6 mm AWG 23) 		5 m (15 feet)		190 m (625 feet)	60 m (195 feet)	150 m (495 feet)	
0,5 mm ² (Ø 0,8 mm AWG 20) 		25 m (85 feet)	25 m (85 feet)	190 m (625 feet)	60 m (195 feet)	150 m (495 feet)	
1 mm ² (Ø 1,2 mm AWG 17) 		50 m (165 feet)	50 m (165 feet)	190 m (625 feet)	60 m (195 feet)	150 m (495 feet)	
1 mm ² (Ø 1,2 mm AWG 17) 		50 m (165 feet)	50 m (165 feet)	120 m (395 feet)	40 m (130 feet)	100 m (330 feet)	
1,5 mm ² (Ø 1,4 mm AWG 15) 		75 m (245 feet)	100 m (330 feet)	190 m (625 feet)	60 m (195 feet)	150 m (495 feet)	
2,5 mm ² (Ø 1,8 mm AWG 13) 		100 m (330 feet)	150 m (495 feet)	190 m (625 feet)	60 m (195 feet)	150 m (495 feet)	

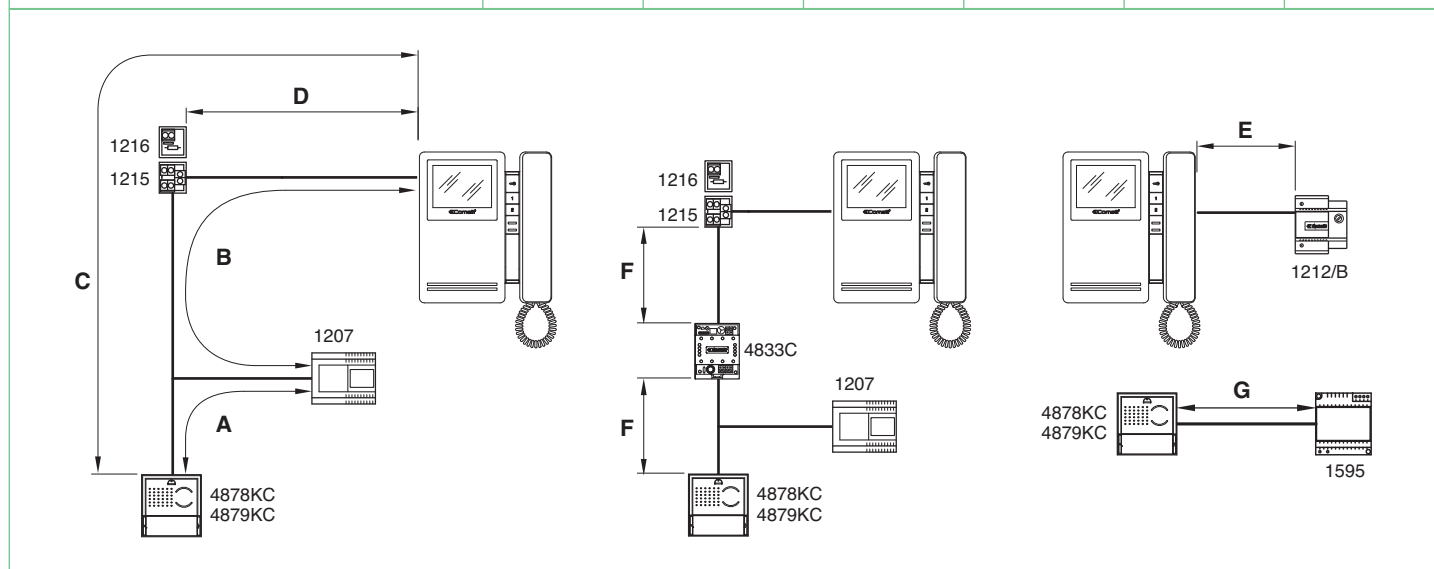

Operation



In case of a persistent short-circuit on the bus line, the external unit emits an intermittent signalling tone.

When the visitor presses the call button, caller illumination and the internal call ringtone (if the Privacy function is not enabled) are activated and image is displayed on the main monitor/s for approx. 60 seconds.

The maximum duration of the conversation between the external and internal units is 90 seconds.

A call confirmation tone sounds at the external unit; in systems with 2 or more entrances, if the external unit gives a busy tone instead of replicating the ringtone, this means that another communication is already in progress with another external unit.

For programming user addresses different from the factory settings (1 and 2), see page 26.

For the intercom functions of the Magis Kit System, see page 29.

Description of button functions and settings

Settings for monitor Art. 6402E and Style door-entry phone

Position of the microswitches for monitor Art. 6402E

► For door-entry phones Art. 2608, Art. 2610 and Art. 2628, set dip switches **S1-6, S1-7, S1-8** to **OFF**

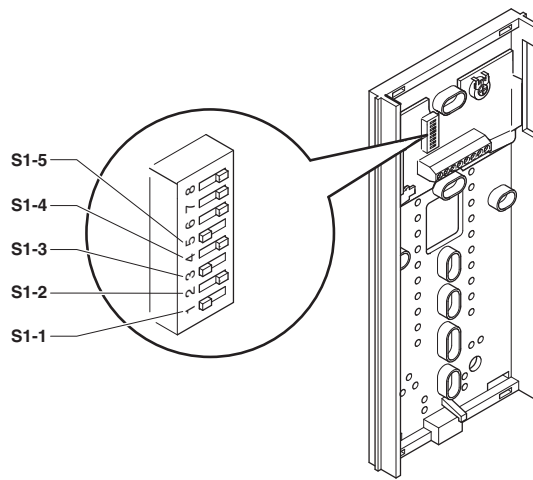
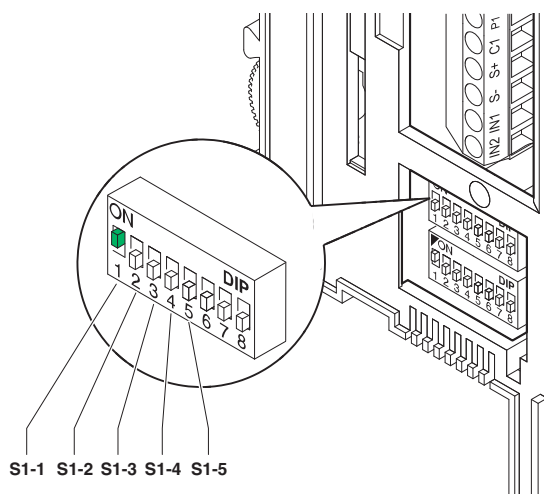

The values of **S1-1, S1-2, S1-3, S1-4** and **S1-5** define the **call address** of the monitor and door-entry phones as shown in the table below.

TAB. A Riser addresses

Code	S1	Code	S1	Code	S1	Code	S1
1		9		17		25	
2		10		18		26	
3		11		19		27	
4		12		20		28	
5		13		21		29	
6		14		22		30	
7		15		23			
8		16		24			

Description of functions

For two-family intercom calls (between door-entry phones and/or door entry monitors), set the 2 users to contiguous call addresses (marked with the same letter AA..CC..OO in the microswitch programming table on page 26).

🔑 **Door opener:** Pressing the Door opener Pushbutton triggers the lock connected to the external unit.

Actuator: Pressing Pushbutton 1 set to Actuator mode allows activation of Art. 1256, which can be used, for example, to open gates, swinging doors or to activate the cyclic camera module Art. 1259/C.

Free Pushbutton: The indication Free Pushbutton means that it is possible to use Pushbutton 1 as a C.NO. contact in the terminal board using suitable settings, as illustrated in variant SB2/AAM2 pag. 139.

Self-ignition / Video request

- Self-ignition can be disabled.
- Self-ignition is possible only when the system is in standby.
- Self-ignition is recommended only for systems with 1 or 2 entrances.

Press button 2 in this mode to display the image transmitted by the

external unit on the monitor, even if no call has been made. In systems with 2 external units, it is possible to view the image from one external unit or the other alternately ("toggle" function) by pressing button 2. On secondary monitors (**S2 DIP8 ON**), button 2 also has the video request function and can be used to switch on a monitor on receipt of a call from the external unit.

- Enabling:
- press the monitor self-ignition button and hold for longer than 4 seconds. » confirmation ringtone.
- Disabling:
- press the self-ignition button and hold for longer than 4 seconds. » 4 confirmation tones.
- Ignition:
- press and immediately release the specific button (button 2 - if the factory settings have been retained).

Switchboard call

Press the button set in this mode to transmit a call to the porter switchboard.

Single-family intercom call

This function can be used to transmit a call to the other units (door entry monitors and/or door-entry phones) set to the same call address.

► By lifting the handset, the receiver of the call starts communicating with the caller. Communication is ended by hanging up the handset. An intercom call does not have priority over a conversation/call with the external unit. In this case, during an intercom call attempt, the LED indicator will flash for a few seconds to signal that the system is busy.

Call from the external unit

In any case, a call from the external unit always takes priority over intercom communication. In this case, users who are already speaking will hear a tone similar to the ringtone in the handset if the call is for them, otherwise a triple signal tone will sound.

► To answer the call from the external unit, simply lift the handset of any free unit or hang up and lift the handset of a unit engaged in the intercom call.

Doctor

This function enables automatic activation of the lock-release when a call is made from an external unit to the address of the internal unit for which the function was enabled.

Enabling/Disabling:

- press the button set for this function and hold for 2 seconds.
- » when the function is enabled, the LED indicator stays on.

Additional main or secondary monitors

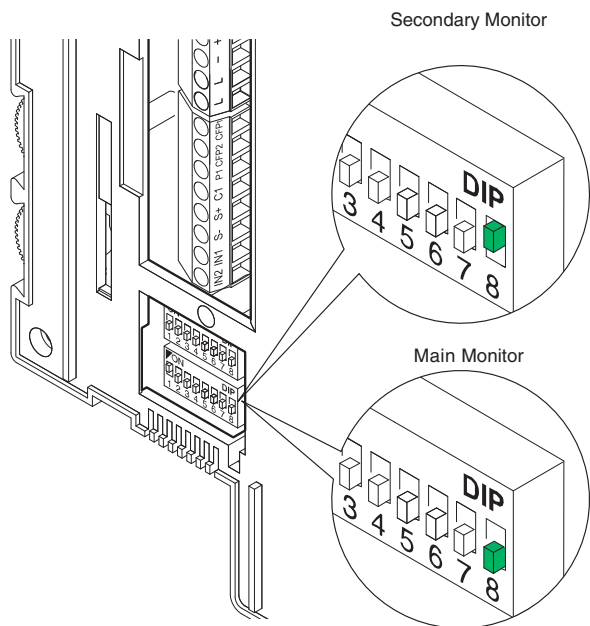

The setting of S2 DIP 8 defines whether the bracket in question will be managed as main (M) or secondary (S).

The external unit can manage up to a maximum of 4 door entry monitors or door-entry phones for each call button.

In the classic Magis Kit configuration, it is therefore possible to have at most 2 secondary door entry monitors and 2 main door entry monitors for each call button, all powered by the same Art. 1207.

It is possible to manage up to 3 main door entry monitors within the same family unit (i.e. set to the same user code). In this particular configuration, the additional main door entry monitors must each be powered by the special Art. 1212/B (see variant MSK/HCA and MSK/IC, page 132, 133). When a call is made from the external unit, the monitor switched on will be the main door entry monitor.

Any other secondary monitors in the same family unit will remain off.

When responding to a call from the external unit using a secondary door entry monitor, the image is automatically displayed on the monitor.

At this point, the main door entry monitor switches off and the image appears on the door entry monitor on which the 2 Self-ignition / Video request button was pressed.

To display the image without activating audio communication with the external unit, press the 2 button - Self-ignition / Video request.

Using the kit in systems with a main entrance

The diagrams MSK/EN/109IC and MSK/EN/110IC on page 128 and 131 show a possible system configuration for managing up to a max. of 30 Magis Kits with one Art. 4680C - Art. 4680KC* placed, for example, at the entrance of a residential complex.

Using these system diagrams, it is possible to call one of the Magis Kits from the main entrance equipped with Art. 4680C - Art. 4680KC*.

In this configuration it is necessary to program the buttons of Art. 4680KC on Art.4879KC (as illustrated in the procedure below); the internal units should also be programmed with the corresponding code (see table on page 26).

For further information on the integration of Magis Kits into Simplebus systems and the programming of the main entrance (Art. 4680C - Art. 4680KC*), refer to the catalogue (no. 140) and the technical manual cod. 2G40000472.

*** Operating restrictions for Art. 4680KC**

Art. 4680KC manages calls originating from **ONLY** digital or button modules if they fall between address 1 and address 10.

Programming buttons on Art. 4680KC

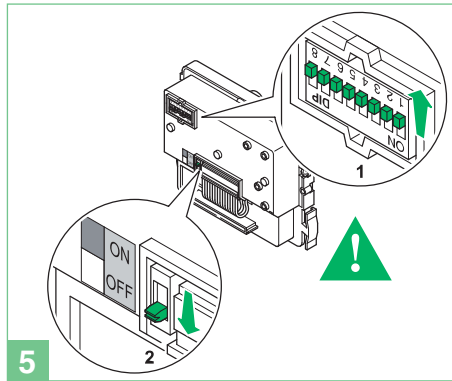
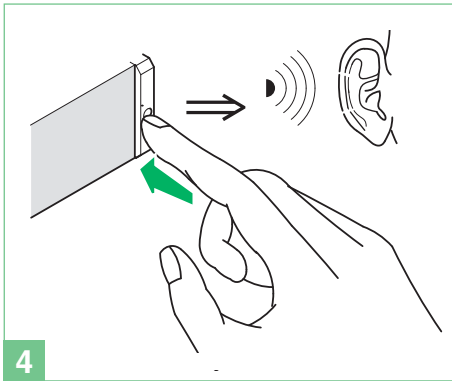
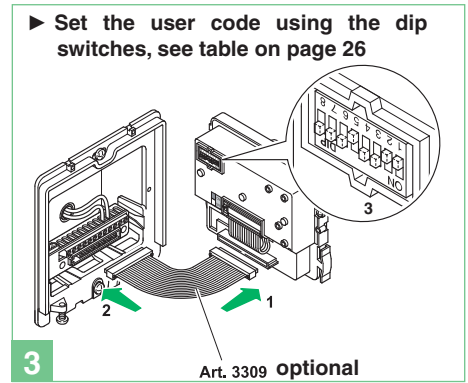
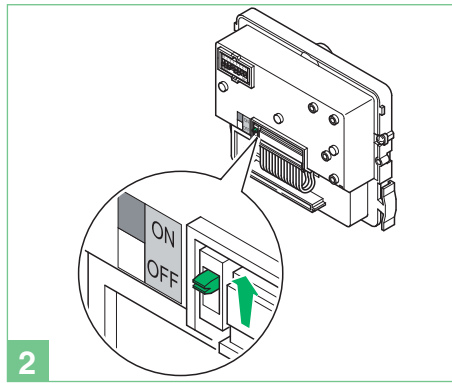
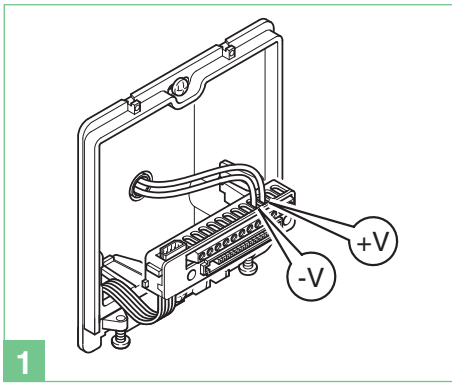

Default button settings

DIP S2								with Art. 6433, 6434			
DIP 1	DIP 2	DIP 3	DIP 4	P1	P2			P3	P4	P5	P6
0	0	0	0	CCS	AI	🔑	☎️	ACT	D	PAN	K
1	0	0	0	ACT	AI			INT	INTb	D	CCS
0	1	0	0	INT	AI	🔑	☎️	INTb	ACT	CCS	CCP
1	1	0	0	ACT	CCS			ACT	PAN	K	D
0	0	1	0	ACT	ACT	🔑	☎️	ACT	ACT	ACT	ACT
1	0	1	0	INT	ACT			CCS	CCP	INTb	PAN
0	1	1	0	AI	D	🔑	☎️	K	CCS	CCP	INTb
1	1	1	0	INTb	INT			AI	INT	PAN	D
0	0	0	1	CCS	PAN	🔑	☎️	D	AI	INT	INTb
1	0	0	1	K	CCS			PAN	CCP	AI	INT
0	1	0	1	CCP	K	🔑	☎️	PAN	ACT	INT	AI
1	1	0	1	PAN	CCP			CCS	K	ACT	D
0	0	1	1	D	INTb	🔑	☎️	INT	ACT	AI	CCS
1	0	1	1	INT	INT			INT	INT	INT	INT
0	1	1	1	NULL	NULL	NULL	NULL	NULL	NULL	NULL	NULL
1	1	1	1						PROG		

Legend

🔑	Lock- release	CCS	Switchboard call	INTb	Two-family intercom - for KIT only
☎️	Speech	K	Guardian door-entry phone call	NULL	No function
ACT	Actuator	D	Doctor	PROG	Programmed functions, see pages 28-29-30-31 In this Dip switch setting, the buttons control the programmed functions; the NON-programmed buttons control functions referred to on line 0000
AI	Self-ignition	PAN	Panic		
CCP	Main switchboard call	INT	Programmable intercom, general or selective - standard single-family calling for KIT and Simplebus Top		

! General button programming warnings

If the default settings (see table on page 28) do not reflect requirements, the buttons can be programmed differently by carrying out the steps below. At the end, set S2 DIP switches 1-2-3-4 to the combination 1111 (PROG setting in the configuration tables on pages 28, 29, 30, 31). In this dip switch setting, the buttons control the programmed functions;

the NON-programmed buttons control functions referred to on line 0000 (see table on page 28). Restore the user code setting on S1, see table A on page 26.

Programming buttons for generic or coded actuator

DIP S2								with Art. 6433, 6434				DIP S1	
DIP 1	DIP 2	DIP 3	DIP 4	P1	P2			P3	P4	P5	P6	ADDRESS 12345678	
0	0	0	0					ACT					
1	0	0	0	ACT									
0	1	0	0						ACT				
1	1	0	0	ACT									
0	0	1	0	ACT	ACT	ACT		ACT	ACT	ACT	ACT		
1	0	1	0		ACT								
0	1	1	0										
1	1	1	0										
0	0	0	1										
1	0	0	1										
0	1	0	1						ACT				
1	1	0	1							ACT			
0	0	1	1						ACT				
1	0	1	1										
0	1	1	1										
1	1	1	1										
PROG													

Example:

on a monitor with user code 5, P1 programming = generic actuator, P2 = coded actuator (code 125).

1. Set S2 DIP switch 5-6 to the combination 01.

» the LED (green) flashes.

2. Refer to the table on page 29 and select a combination in which the actuator function (ACT) is listed for the buttons you wish to program.

E.g.: for P1= generic actuator, set S2 DIP switches 1-2-3-4 to the combination 1000 or 1100 or 0010 (P1=ACT), set S1 DIP switches to the combination 11111111, go to point 3.

E.g.: for P2= coded actuator (code 125), set S2 DIP switches 1-2-3-4 to the combination 0010 or 1010 (P2=ACT), set S1 with address 125 in accordance with table C on page 31, go to point 3.

3. Press and release the button to be associated with the function.

» the LED (green) lights up.

» confirmation tone in handset.

4. To exit programming mode, set S2 DIP switches 5-6 to the combination 00.

» the LED (green) switches off.

5. When programming is complete, set S2 DIP switches 1-2-3-4 to the combination 1111. Restore the user code setting on S1, see table C on page 31.

Programming for intercom call



General and selective intercoms **CANNOT** be used together on the same riser.

Programming/deleting intercom address (selective intercom only)

S1	2)						S2	3)
	DIP 1	DIP 2	DIP 3	DIP 4	DIP 5	DIP 6		
<p>1)</p> <p>Programming: set code, TAB. B on page 29</p>	0	0	0	1	1	1	 	
<p>DIP ON</p>	1	1	1	1	1	1	 	



Take note of the S2, S1 setting and restore it when programming is complete.

TAB. B Selective intercom addresses

Code	Dip switch ON	S1	Code	Dip switch ON	S1	Code	Dip switch ON	S1
1	1		4	4		7	7	
2	2		5	5		8	8	
3	3		6	6				

You must set the intercom address on all the riser's internal units.
 You can assign the same intercom address to a maximum of 3 internal units.
 For group calls, select the desired intercom codes simultaneously (max. 3).

Programming buttons for intercom call													
DIP S2				with Art. 6433, 6434								DIP S1	
DIP 1	DIP 2	DIP 3	DIP 4	P1	P2			P3	P4	P5	P6	ADDRESS 1 2 3 4 5 6 7 8	
0	0	0	0										
1	0	0	0					INT	INTb				
0	1	0	0	INT				INTb					
1	1	0	0										
0	0	1	0							INTb			
1	0	1	0	INT							INTb		
0	1	1	0						INT				
1	1	1	0	INTb	INT								
0	0	0	1							INT	INTb		
1	0	0	1							INT	INT		
0	1	0	1							INT			
1	1	0	1					INT					
1	0	1	1	INT	INT			INT	INT	INT	INT		
0	1	1	1										
1	1	1	1										
PROG													

Example 1 - Selective intercom

on a monitor with user code 1 and intercom address 1, P3 programming = selective intercom with address 2, P4 = selective intercom with address 3.

Example 2 - KIT intercom

(intercom between 2 contiguous addresses in the range from 1 to 30, with the first being an odd number):

on a monitor with user code 1, P3 programming = general internal call, P4 = two-family intercom with address 2.

- Set S2 DIP switch 5-6 to the combination 01.
» the LED (green) flashes.
- Refer to the table on page 30 and select a combination in which the intercom function (INT or INTb) is listed for the buttons you wish to program.

E.g. 1: for P3= single-family intercom, set S2 DIP switches 1-2-3-4 to the combination 1000 or 0011 or 1011 (P3=INT), set S1 with address 2 in accordance with **table B** on page 29, go to point 3.

E.g. 1: for P4= selective intercom, set S2 DIP switches 1-2-3-4 to the

combination 1110 or 1011 (P4=INT), set S1 with address 3 in accordance with **table B** on page 29, go to point 3.

E.g. 2: for P3= general internal call and P4= two-family intercom, set S2 DIP switches 1-2-3-4 to the combination 1000 (P3=INT, P4=INTb), set S1 with user code 1 in accordance with **table A** on page 26, go to point 3.

- Press and release the button to be associated with the function.
» the LED (green) lights up.
» confirmation tone in handset.
- To exit programming mode, set S2 DIP switches 5-6 to the combination 00.
» the LED (green) switches off.
- When programming is complete, set S2 DIP switches 1-2-3-4 to the combination 1111. Restore the user code setting on S1, see table A on page 26.**

Programming buttons for other functions												
DIP S2				with Art. 6433, 6434								
DIP 1	DIP 2	DIP 3	DIP 4	P1	P2			P3	P4	P5	P6	
0	0	0	0	CCS	AI				D	PAN	K	
1	0	0	0		AI					D	CCS	
0	1	0	0		AI					CCS	CCP	
1	1	0	0		CCS			CCP	PAN	K	D	
0	0	1	0									
1	0	1	0									
0	1	1	0	AI	D			CCS	CCP		PAN	
1	1	1	0					K	CCS	CCP	D	
0	0	0	1	CCS	PAN			AI				
1	0	0	1	K	CCS			PAN	CCP	AI		
0	1	0	1	CCP	K			PAN			AI	
1	1	0	1	PAN	CCP			CCS	K		D	
0	0	1	1	D						AI	CCS	
1	0	1	1									
0	1	1	1	NULL	NULL	NULL	NULL	NULL	NULL	NULL	NULL	NULL
PROG												

Legend

	Lock- release	CCS	Switchboard call	NULL	No function
	Speech	K	Guardian door-entry phone call	PROG	Programmed functions
AI	Self-ignition	D	Doctor		
CCP	Main switchboard call	PAN	Panic		

Example:

on a monitor with user code 5, P5 programming = self-ignition, P6 = switchboard call.

- Set S2 DIP switch 5-6 to the combination 01.
» the LED (green) flashes.
- Refer to the table on page 30 and select a combination in which the desired/necessary functions are listed for the buttons you wish to program.

E.g.: for P5= self-ignition, P6= switchboard call, set S2 DIP switches 1-2-3-4 to the combination 0011 (P5=AI, P6=CCS).

- Press and release the button to be associated with the function.
» the LED (green) lights up.
» confirmation tone in handset.
- To exit programming mode, set S2 DIP switches 5-6 to the combination 00.
» the LED (green) switches off.
- When programming is complete, set S2 DIP switches 1-2-3-4 to the combination 1111.**



TAB.C Riser addresses

Code	Dip switch ON	Code	Dip switch ON	Code	Dip switch ON	Code	Dip switch ON	Code	Dip switch ON	Code	Dip switch ON	Code	Dip switch ON	Code	Dip switch ON
1	1	31	1,2,3,4,5	61	1,3,4,5,6	91	1,2,4,5,7	121	1,4,5,6,7	151	1,2,3,5,8	181	1,3,5,6,8	211	1,2,5,7,8
2	2	32	6	62	2,3,4,5,6	92	3,4,5,7	122	2,4,5,6,7	152	4,5,8	182	2,3,5,6,8	212	3,5,7,8
3	1,2	33	1,6	63	1,2,3,4,5,6	93	1,3,4,5,7	123	1,2,4,5,6,7	153	1,4,5,8	183	1,2,3,5,6,8	213	1,3,5,7,8
4	3	34	2,6	64	7	94	2,3,4,5,7	124	3,4,5,6,7	154	2,4,5,8	184	4,5,6,8	214	2,3,5,7,8
5	1,3	35	1,2,6	65	1,7	95	1,2,3,4,5,7	125	1,3,4,5,6,7	155	1,2,4,5,8	185	1,4,5,6,8	215	1,2,3,5,7,8
6	2,3	36	3,6	66	2,7	96	6,7	126	2,3,4,5,6,7	156	3,4,5,8	186	2,4,5,6,8	216	4,5,7,8
7	1,2,3	37	1,3,6	67	1,2,7	97	1,6,7	127	1,2,3,4,5,6,7	157	1,3,4,5,8	187	1,2,4,5,6,8	217	1,4,5,7,8
8	4	38	2,3,6	68	3,7	98	2,6,7	128	8	158	2,3,4,5,8	188	3,4,5,6,8	218	2,4,5,7,8
9	1,4	39	1,2,3,6	69	1,3,7	99	1,2,6,7	129	1,8	159	1,2,3,4,5,8	189	1,3,4,5,6,8	219	1,2,4,5,7,8
10	2,4	40	4,6	70	2,3,7	100	3,6,7	130	2,8	160	6,8	190	2,3,4,5,6,8	220	3,4,5,7,8
11	1,2,4	41	1,4,6	71	1,2,3,7	101	1,3,6,7	131	1,2,8	161	1,6,8	191	1,2,3,4,5,6,8	221	1,3,4,5,7,8
12	3,4	42	2,4,6	72	4,7	102	2,3,6,7	132	3,8	162	2,6,8	192	7,8	222	2,3,4,5,7,8
13	1,3,4	43	1,2,4,6	73	1,4,7	103	1,2,3,6,7	133	1,3,8	163	1,2,6,8	193	1,7,8	223	1,2,3,4,5,7,8
14	2,3,4	44	3,4,6	74	2,4,7	104	4,6,7	134	2,3,8	164	3,6,8	194	2,7,8	224	6,7,8
15	1,2,3,4	45	1,3,4,6	75	1,2,4,7	105	1,4,6,7	135	1,2,3,8	165	1,3,6,8	195	1,2,7,8	225	1,6,7,8
16	5	46	2,3,4,6	76	3,4,7	106	2,4,6,7	136	4,8	166	2,3,6,8	196	3,7,8	226	2,6,7,8
17	1,5	47	1,2,3,4,6	77	1,3,4,7	107	1,2,4,6,7	137	1,4,8	167	1,2,3,6,8	197	1,3,7,8	227	1,2,6,7,8
18	2,5	48	5,6	78	2,3,4,7	108	3,4,6,7	138	2,4,8	168	4,6,8	198	2,3,7,8	228	3,6,7,8
19	1,2,5	49	1,5,6	79	1,2,3,4,7	109	1,3,4,6,7	139	1,2,4,8	169	1,4,6,8	199	1,2,3,7,8	229	1,3,6,7,8
20	3,5	50	2,5,6	80	5,7	110	2,3,4,6,7	140	3,4,8	170	2,4,6,8	200	4,7,8	230	2,3,6,7,8
21	1,3,5	51	1,2,5,6	81	1,5,7	111	1,2,3,4,6,7	141	1,3,4,8	171	1,2,4,6,8	201	1,4,7,8	231	1,2,3,6,7,8
22	2,3,5	52	3,5,6	82	2,5,7	112	5,6,7	142	2,3,4,8	172	3,4,6,8	202	2,4,7,8	232	4,6,7,8
23	1,2,3,5	53	1,3,5,6	83	1,2,5,7	113	1,5,6,7	143	1,2,3,4,8	173	1,3,4,6,8	203	1,2,4,7,8	233	1,4,6,7,8
24	4,5	54	2,3,5,6	84	3,5,7	114	2,5,6,7	144	5,8	174	2,3,4,6,8	204	3,4,7,8	234	2,4,6,7,8
25	1,4,5	55	1,2,3,5,6	85	1,3,5,7	115	1,2,5,6,7	145	1,5,8	175	1,2,3,4,6,8	205	1,3,4,7,8	235	1,2,4,6,7,8
26	2,4,5	56	4,5,6	86	2,3,5,7	116	3,5,6,7	146	2,5,8	176	5,6,8	206	2,3,4,7,8	236	3,4,6,7,8
27	1,2,4,5	57	1,4,5,6	87	1,2,3,5,7	117	1,3,5,6,7	147	1,2,5,8	177	1,5,6,8	207	1,2,3,4,7,8	237	1,3,4,6,7,8
28	3,4,5	58	2,4,5,6	88	4,5,7	118	2,3,5,6,7	148	3,5,8	178	2,5,6,8	208	5,7,8	238	2,3,4,6,7,8
29	1,3,4,5	59	1,2,4,5,6	89	1,4,5,7	119	1,2,3,5,6,7	149	1,3,5,8	179	1,2,5,6,8	209	1,5,7,8	239	1,2,3,4,6,7,8
30	2,3,4,5	60	3,4,5,6	90	2,4,5,7	120	4,5,6,7	150	2,3,5,8	180	3,5,6,8	210	2,5,7,8	*240	5,6,7,8

*NOTE: code 240 is reserved for the porter switchboard

Programming reset

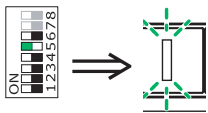
! 1)	! 2)						3)	4)
S1	DIP 1	DIP 2	DIP 3	DIP 4	DIP 5	DIP 6	S2	S1/S2/LED1
<p>DIP ON</p>	1	1	1	1	1	1		<p>5 sec</p> <p>2 sec</p>
<p>Factory settings:</p> <ul style="list-style-type: none"> • Button functions for the S2 DIP switch 1-2-3-4 combination; • Intercom address absent; • Range function and min./max. addresses absent; • Ringtone reset; • IN 1 input ⇒ LED (default). 								

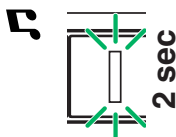
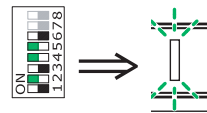
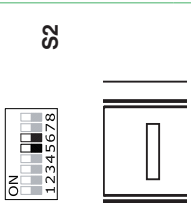
Carry out steps 1 to 4		2) !						3)		4)	
1) !		DIP 1	DIP 2	DIP 3	DIP 4	DIP 5	DIP 6	S2	S1/S2/LED1		
Programming range/ringtones	S1										
Range minimum address	set code, TAB. C on page 31	0	0	0	0	1	0				
Range maximum address											
Enable range											
Disable range											
Select polyphonic ringtone											
Select tone sound (default)		0	1	0	1	1	0				

Carry out steps 1 to 4																				
		1)				2)		3)		4)										
Programming input IN1 for LED/alarm/lock-release/actuator indication		S1		DIP		S2				S1/S2/LED1										
				DIP 1		DIP 2		DIP 3		DIP 4		DIP 5		DIP 6						
IN 1 input ⇒ LED (default), see page 138				0	0	0	1	1	0											
Input IN 1 ⇒ ALARM, see page 138				0	0	0	1	1	0											
Input IN 1 ⇒ LOCK-RELEASE, see page 138				0	0	1	0	1	0											
Input IN 1 ⇒ CODED ACTUATOR, see page 138	set code, TAB. C on page 31			0	0	1	0	1	0											
Input IN 1 ⇒ GENERIC ACTUATOR, see page 138																				

Direct programming of intercom call

Allows direct programming of intercom call via the internal units.
 ✓ Requires 2 operators.

Step 1: enter programming mode

Operator 1 and Operator 2 carry out the following procedures on 2 internal units:

1. Set S2 DIP switches 1-2 -3-4 to the combination 1111.
2. Lift the handset.

3. Press and hold buttons 1 and 2 for 3 sec.

» *The internal unit emits 1 tone.*

» *The green LED flashes.*

» *The internal unit enters audio mode.*

» *At this point the 2 operators will be communicating with each other.*

Step 2: intercom call programming

Operator 1:

▶ Press the button you want to program to call operator 2 (e.g. 2).

» *The internal unit manned by operator 1 emits a confirmation tone.*

Operator 2:

▶ Press the button you want to program to call operator 1 (e.g. 1).

» *The internal unit manned by operator 2 emits a confirmation tone.*

Operator 1/Operator 2:

▶ Hang up the handset.

» *The internal unit emits 1 tone.*

» *Programming of the 2 internal units is now complete.*

To program another internal unit, move on to STEP 3.

Step 3: programming other internal units

Operator 1/Operator 2:

1. Once the new station has been reached, carry out step 1 to begin communication.

2. Repeat step 2.

NOTE If a call is received during programming, it must be answered and the programming procedure resumed afterwards.

Monitor ringtone selection

1. Press and hold button  until a confirmation tone is emitted (this procedure is only possible with the system in standby; otherwise the LED indicator will flash to warn the user).

2. Press and release button  :

once (1 confirmation tone is emitted) to change the ringtone for calls from the external unit.

twice (2 confirmation tones are emitted) to change the ringtone for calls from the switchboard.

3 times (3 confirmation tones are emitted) to change the ringtone for intercom calls made from the internal unit.

4 times: (4 confirmation tones are emitted) to change the floor door call ringtone.

Any further pressing of button  repeats the sequence described above.

3. Press and release button 1 to scroll through the various available ringtones in sequence.

4. Press button 2 to confirm selection of the last ringtone heard and to exit (at any time) the monitor ringtone change mode. On exiting the monitor ringtone selection mode a confirmation tone will be emitted.

Special programming - Art. 4680KC

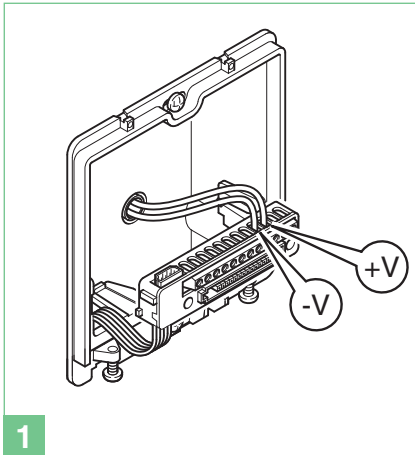

1

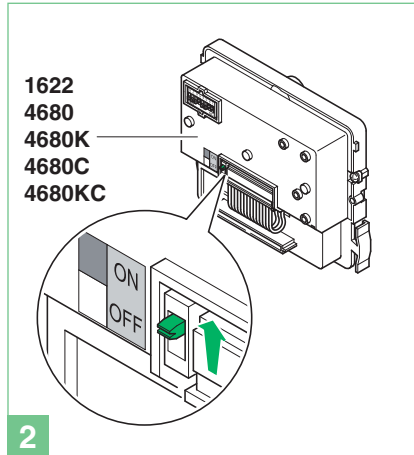

1622
4680
4680K
4680C
4680KC

2

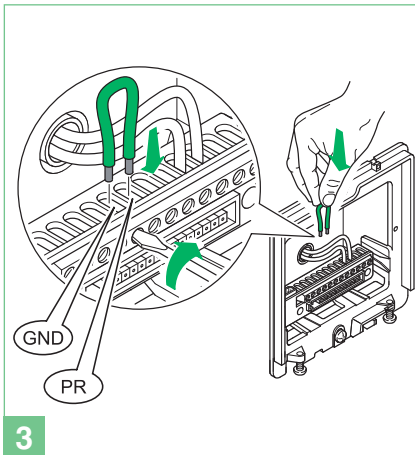

3

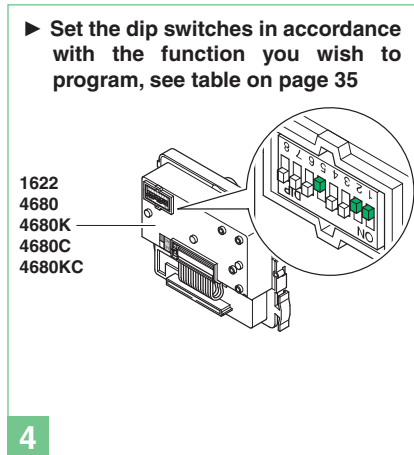

► Set the dip switches in accordance with the function you wish to program, see table on page 35

1622
4680
4680K
4680C
4680KC

4

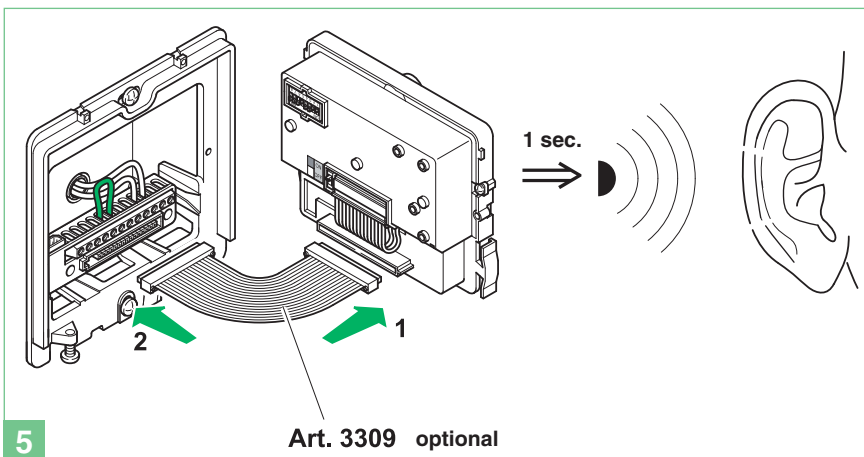

5

Art. 3309 optional

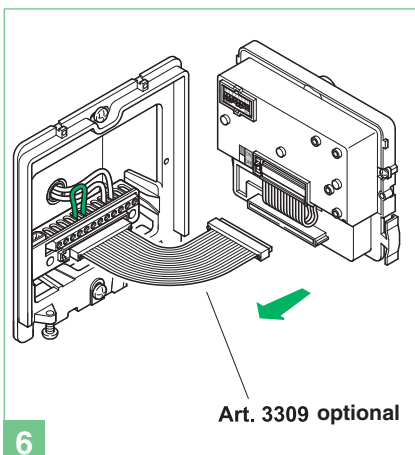

6

Art. 3309 optional

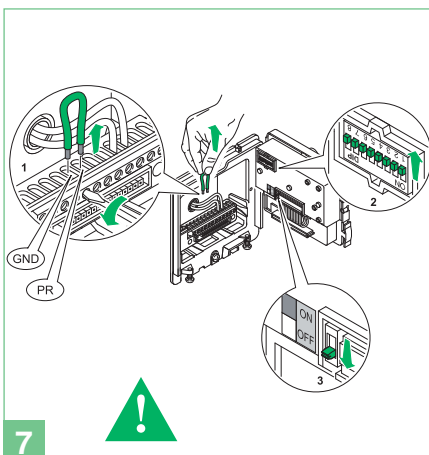

7

Code	Dip switch ON	
De-misting heating element		
213	1,3,5,7,8	OFF (default)
212	3,5,7,8	ON

Audio-visual messages		
210	2,5,7,8	visual messages only
211	1,2,5,7,8	Swedish
214	2,3,5,7,8	OFF (default)
215	1,2,3,5,7,8	Italian
216	4,5,7,8	French
217	1,4,5,7,8	Spanish
218	2,4,5,7,8	Dutch
219	1,2,4,5,7,8	Greek
220	3,4,5,7,8	English
221	1,3,4,5,7,8	German
222	2,3,4,5,7,8	Portuguese

Door lock		
223	1,2,3,4,5,7,8	Door lock command on SE in AC (default)
224	6,7,8	Door lock command on SE in enhanced AC
225	1,6,7,8	Door lock command on SE in DC

245	1,3,5,6,7,8	Door lock time: 2 sec. + disabling tone (default)
246	2,3,5,6,7,8	Door lock time: 4 sec.
247	1,2,3,5,6,7,8	Door lock time: 8 sec.

248	4,5,6,7,8	Door lock confirmation tone: enabled
251	1,2,4,5,6,7,8	C.NC.NO relay in parallel with SE (default)

252	3,4,5,6,7,8	Lock-release always enabled (default)
253	1,3,4,5,6,7,8	Lock-release only enabled for user called

Actuator control management		
NOTE the system should not include Art. 1256 in generic actuator mode.		
229	1,3,6,7,8	Enabling C.NC.NO relay on actuator control: 2 sec.
230	2,3,6,7,8	Enabling C.NC.NO relay on actuator control: 4 sec.
231	1,2,3,6,7,8	Enabling C.NC.NO relay on actuator control: 8 sec.

228	3,6,7,8	Actuator function on S serial line = disabled (default)
227	1,2,6,7,8	Actuator function on S serial line = enabled

System functions		
232	4,6,7,8	Awaiting response time: 60 sec. (default)
233	1,4,6,7,8	Awaiting response time: 120 sec.
234	2,4,6,7,8	Awaiting response time: 30 sec.

235	1,2,4,6,7,8	Talk time: 90 sec. (default)
236	3,4,6,7,8	Talk time: 180 sec.

237	1,3,4,6,7,8	Self-ignition: enabled (default)
238	2,3,4,6,7,8	Self-ignition: disabled

239	1,2,3,4,6,7,8	Confirmation tone on user call = enabled (default)
240	5,6,7,8	Confirmation tone on user call = disabled

243	1,2,5,6,7,8	Reset wait time: 10 sec. (default)
244	3,5,6,7,8	Reset wait time: 1 sec.

208	5,7,8	Reset after lock-release in audio: enabled (default)
209	1,5,7,8	Reset after lock-release in audio: disabled
249	1,4,5,6,7,8	Call transmission: single (default)
250	2,4,5,6,7,8	Call transmission: triple

254	2,3,4,5,6,7,8	Restore default
-----	---------------	------------------------

NE

Avertissements

- Effectuer l'installation en suivant scrupuleusement les instructions fournies par le constructeur et conformément aux normes en vigueur.
- Tous les appareils doivent être strictement destinés à l'emploi pour lequel ils ont été conçus. La société **Comelit Group S.p.A.** décline toute responsabilité en cas de mauvais usage des appareils, pour des modifications effectuées par d'autres personnes pour n'importe quelle raison et pour l'utilisation d'accessoires et matériaux non d'origine.
- Tous les produits sont conformes aux prescriptions de la directive 2006/95/CE (qui remplace la directive 73/23/CEE et amendements successifs), avec marquage **CE**.
- Éviter de placer les fils de montant à proximité des câbles d'alimentation (230/400V).
- Ne jamais introduire d'objets, ni verser de liquides, à l'intérieur du dispositif.
- Les interventions d'installation, de montage et d'assistance aux appareils électriques doivent être effectuées exclusivement par des électriciens spécialisés.
- Couper l'alimentation avant d'effectuer toute opération d'entretien.
- Relier le cadre porte-modules à la terre (voir Fig.).
- Ne pas maintenir le crochet phonie enfoncé lorsque le combiné est décroché.
- La caméra ne doit pas être installée face à de fortes sources de lumière ni dans des lieux où la personne filmée est fortement à contre-jour. Pour résoudre le problème précédemment décrit, il est conseillé de modifier la hauteur d'installation de la caméra, normalement à 160 - 165 cm, en la plaçant à une hauteur de 180 cm et d'orienter l'objectif vers le bas de manière à améliorer la qualité des prises de vue.
- Les caméras avec capteur CCD couleurs présentent, dans des conditions de mauvaise luminosité, une sensibilité inférieure par rapport aux caméras en noir et blanc. Par conséquent, dans les milieux faiblement éclairés, il est conseillé de prévoir une source d'éclairage supplémentaire.

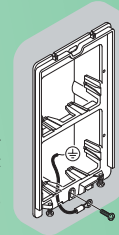

Généralités	37
Poste extérieur	37
Art. 4879KC	37
Art. 1207	37
Installation poste extérieur	37
Installation étiquettes porte-noms	38
Postes Intérieurs	39
Montage poste intérieur Magis	39
Retrait du moniteur	39
Art. 6402E	40
Description moniteur	40
Art. 2608	41
Installation combiné parlophonique Art. 2608	41
Indications générales d'installation et fonctionnement	42
Tableau distances de fonctionnement	42
Fonctionnement	42
Description programmations et fonctions boutons	43
Réglage du moniteur Réf. 6402E et du combiné parlophonique Style	43
TAB. A Adresse de montant	43
Description fonctions	43
Moniteurs supplémentaires principaux ou secondaires	44
Utilisation du kit sur les installations avec porte principale	44
Programmation Art. 4680KC	45
Configuration des boutons par défaut	45
Recommandations générales pour la programmation des boutons	45
Programmation des boutons pour actionneur générique ou particulier	46
Programmation pour appel intercommunicant	46
Programmation/effacement adresse intercommunicant (uniquement pour l'appel intercommunicant sélecteur)	46
TAB. B Adresses intercommunicant sélecteur	46
Programmation des boutons pour appel intercommunicant	47
Programmation des boutons pour d'autres fonctions	47
TAB. C Adresse de montant	48
Reset de programmation	48
Programmation range/sonneries	49
Programmation de l'entrée IN1 pour signal led/alarme/ouvre-porte/actionneur	50
Programmation directe appel intercommunicant	51
Variation sonnerie moniteur	51
Programmations spéciales Art.4680KC	52
Schémas de connexion	
MSK/018IC Schéma base pour kit deux usagers Art. 8172IMC avec connexion en cascade. Mise en service/vérification tensions d'installation au repos.....	121
MSK/013IBC Schéma base pour kit deux usagers Art. 8172IMC avec connexion en dérivation.....	122
MSK/014IBC Schéma pour kit deux usagers Art. 8172IMC complétés avec un second Art. 4879KC. Connexion en dérivation.....	123
MSK/014IAC Schéma pour kit deux usagers Art. 8172IMC complétés avec un second Art. 4879KC. Connexion en cascade.....	124
MSK/018I/AC Schéma pour kit deux usager avec alimentateur complémentaire Art. 1595	125
MSK/019IC Emploi module caméra déportée Art. 1259C.....	126
PXK/EC Branchement relais actionneur Art.1256.....	127
MSK/EN/109IC Schéma pour connexion à porte principale de 2 à 9 Magis kit avec Art. 4834/9	128
MSK/EN/110IC Schéma pour connexion à porte principale de 30 Magis Kit (maximum). Branchement Magis en cascade avec Art. 1424.....	130
SB2/AAR Connexion amplificateur vidéo Art. 4833C.....	132
MSK/HCA Adjonction d'un moniteur principal en parallèle. Connexion en cascade	132
MSK/IC Adjonction d'un moniteur principal en parallèle. Connexion en dérivation	133
MSK/A20S Connexion en cascade du troisième moniteur principal avec alimentation locale.....	133
MSK/A23S Connexion en dérivation de 2 moniteurs principaux et de 2 moniteurs secondaires avec le même code usager.....	134

MSK/A21S Connexion en cascade de 2 moniteurs principaux et de 1 moniteur secondaire avec le même code usager 134
 MSK/AAE Connexion combinés parlophoniques supplémentaires en dérivation du moniteur 135
 MSK/AAD Connexion combinés parlophoniques supplémentaires en cascade du moniteur 135
 MSK/FC Adjonction d'un combiné parlophonique en parallèle en dérivation du montant..... 136
 SB2/X3 Utilisation pour usages divers du bouton P1 (Art. 2608)..... 136
 SB2V/AAK Connexion de dispositifs de répétition d'appel (Art. 1229 ou Art. 1122/A)..... 137
 Variante connexion appel palier 137
 Utilisation de l'entrée IN1 comme contact pour signal LED/ALARME/OUVRE-PORTE/ACTIONNEUR. Activation en fermeture vers CFP2..... 138
 Utilisation de l'entrée IN1 comme contact pour signal LED/ALARME/OUVRE-PORTE/ACTIONNEUR. Activation en présence de tension par rapport à IN2.. 138
 SB2/AAM2 Utilisation pour usages divers du bouton P1 139
 PXX/RTNP Utilisation relais poste extérieur sur ouvre-porte ou commande actionneur (voir programmations spéciales, page 52 : gestion commande actionneur) 139
 PXX/SNP Variante avec gâche de sécurité et alimentation supplémentaire..... 140
 Utilisation du réseau RC pour filtre gâche sur les contacts du relais 140
 PXX/DO Variante utilisation signalisation porte ouverte..... 141

Généralités

Les kits parlophoniques et visiophoniques deux usagers Art. 8172IMC peuvent être utilisés dans des bâtiments privés ou tertiaires dans lesquels un contrôle efficace des accès est demandé face à de simples opérations d'installation.

En effet, 2 conducteurs suffisent entre le poste extérieur et le/s moniteur/s intérieur/s pour activer le système (appel, phonie, vidéo, auto-allumage) plus 2 fils pour alimenter le poste extérieur et la gâche électrique et 2 fils pour alimenter le poste intérieur visiophonique.

En outre, une vaste gamme d'accessoires est disponible pour résoudre facilement chaque exigence d'installation ; en effet, outre des accessoires intéressants de type standard, il est possible d'agrandir l'installation en ajoutant des portiers vidéo et/ou des interphones et/ou des postes extérieurs. Il est ainsi possible d'ajouter au maximum 2 postes extérieurs avec 8 postes intérieurs entre combinés parlophoniques et moniteurs visiophoniques pour la version deux usagers.

Avec une configuration spécifique, on peut effectuer des communications intercommunicantes un usager (c'est-à-dire entre les usagers possédant le même code) en utilisant tant les moniteurs visiophoniques que les combinés parlophoniques.

Plusieurs kits peuvent être reliés à un port principal Simplebus et/ou à un standard Art. 1998A.

Poste extérieur

Art. 4879KC

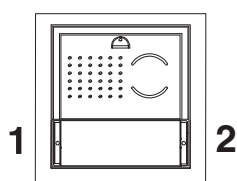

Art. 4879KC

Caractéristiques techniques

Connexion au moniteur avec 2 fils pour audio, vidéo, ouvre-porte et appel plus 2 fils pour alimentation par Art. 1207.

Caméra orientable à haute sensibilité avec capteur CCD 1/3".
 Étiquettes porte-noms avec éclairage à led au choix : bleue, blanche et éteinte.
 Réglage volume haut-parleur.
 Dimensions boîtier à encastrer : 118x118x45 mm.
 Les boutons de l'article réf. 4879KC ont été réglés en usine pour effectuer l'appel aux adresses 1 (bouton de gauche) et 2 (bouton à droite).
 Dimensions poste extérieur : 112x89.5x40 mm.

Description bornier

- LL** connexion moniteur (vidéo, appel, phonie, ouvre-porte).
- V+ V-** alimentation poste extérieur.
- RTE** entrées ouvre-porte local temporisé.
- DO** entrée signalisation porte ouverte.
- PR** borne de programmation.
- GND** borne négative à utiliser en phase de programmation.
- NO NF COM** contacts du relais de 10A.
- SE** connexion gâche électrique.

Art. 1207

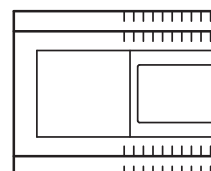

Caractéristiques techniques

Le transformateur prévoit 2 sorties : une pour alimenter le poste extérieur et la gâche électrique, et une pour alimenter le moniteur.
 Dimensions : 105x85x85 mm (6 modules DIN).
 Protégé contre les courts-circuits et les surcharges.

Description bornier

- L $\frac{N}{}$** entrée tension de ligne 110-240 VAC.
- +22V 0V** sortie CC d'alimentation du moniteur.
- +33V 0V** sortie CC pour poste extérieur et gâche électrique.

Installation poste extérieur

► Laisser en position la protection d'installation.

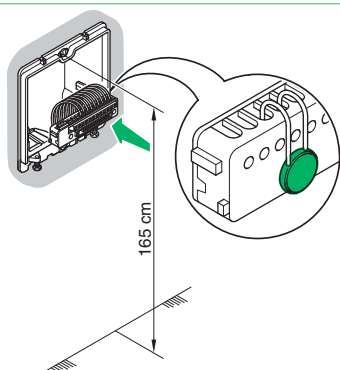

1

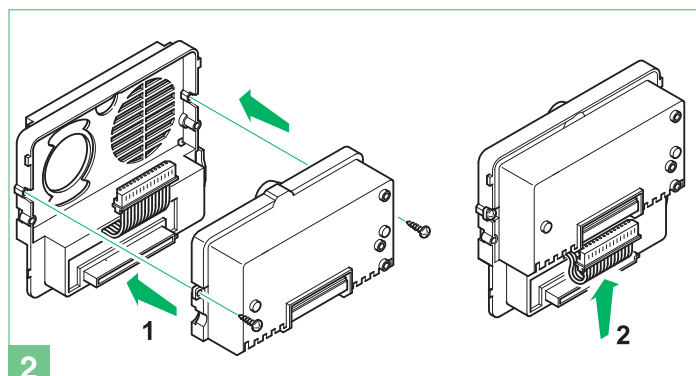

2

► Sélection éclairage leds étiquettes porte-nom

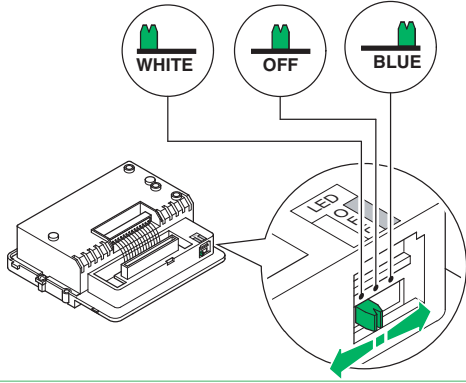

3

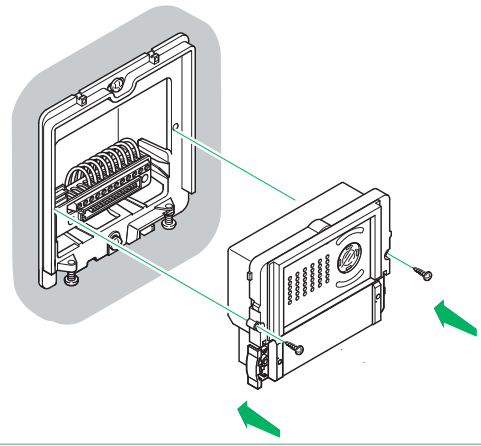

4

Position alternative du micro

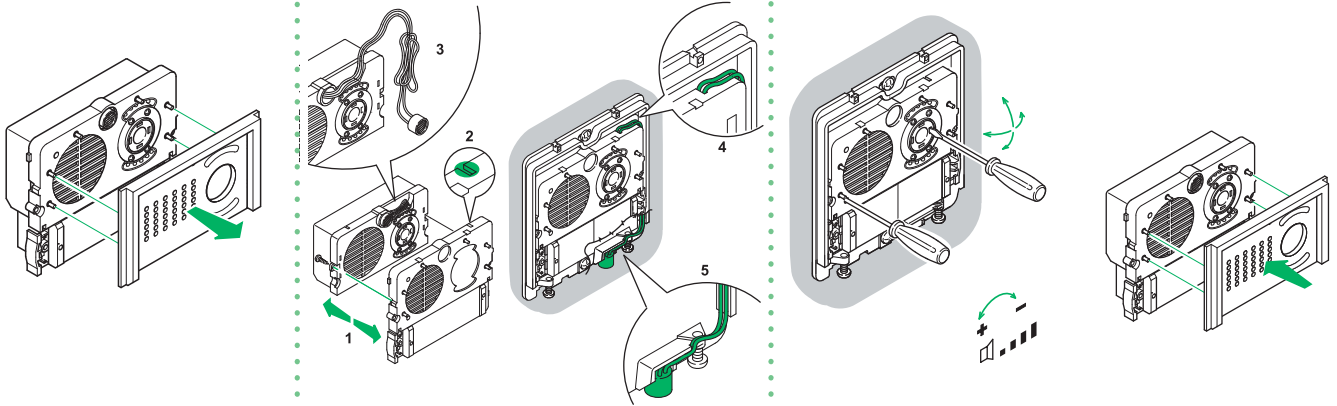

4A

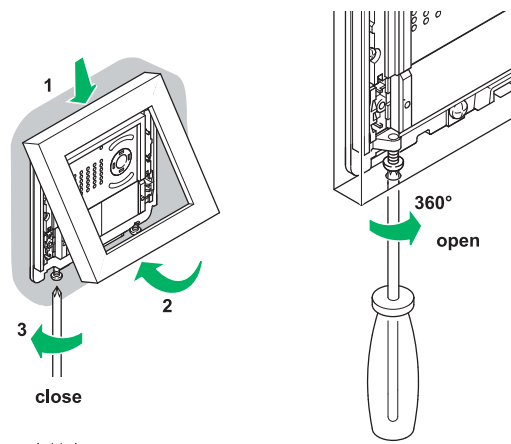

5

Installation étiquettes porte-noms

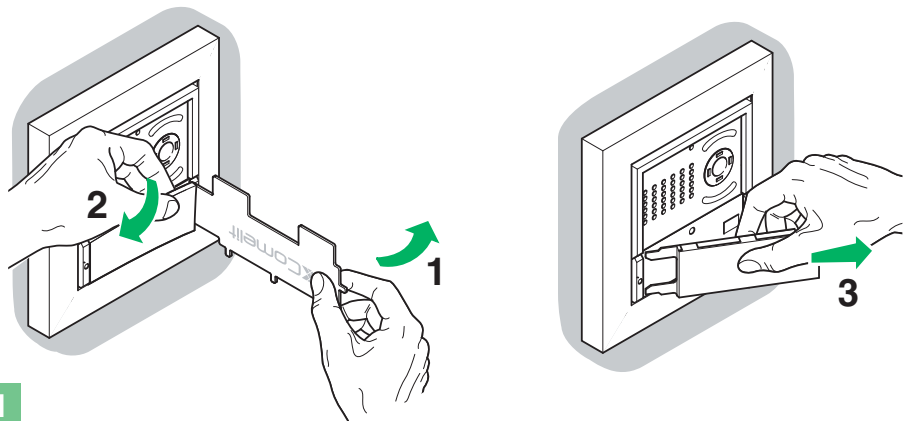

1

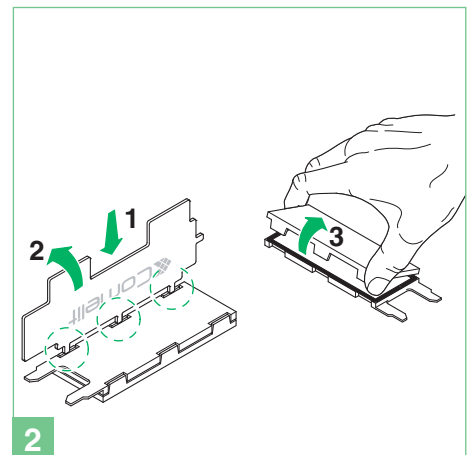

2

► Centrer l'étiquette pour éviter les infiltrations



3

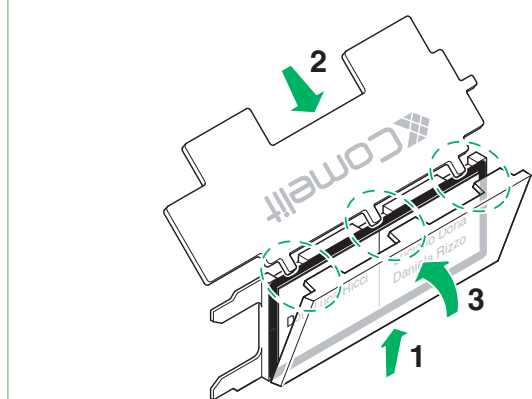

4

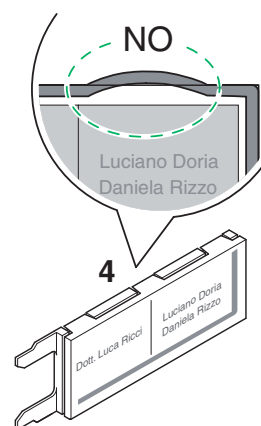

FR

Postes Intérieurs

Montage poste intérieur Magis

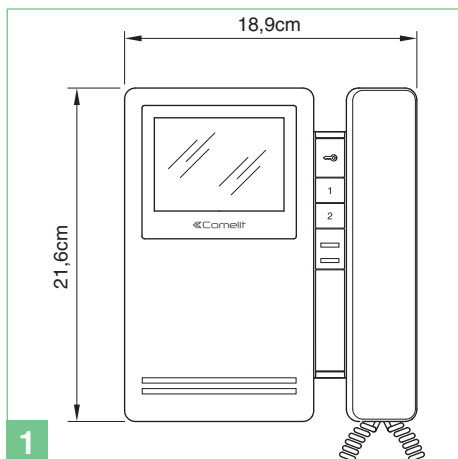

1

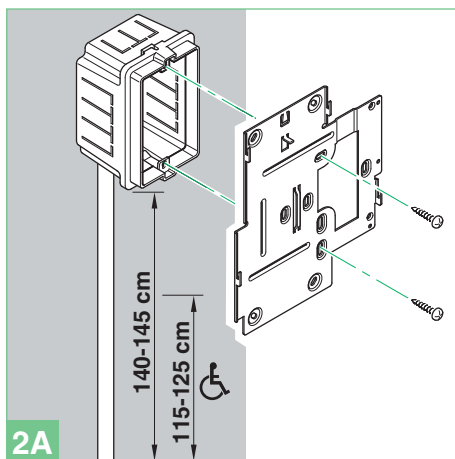

2A

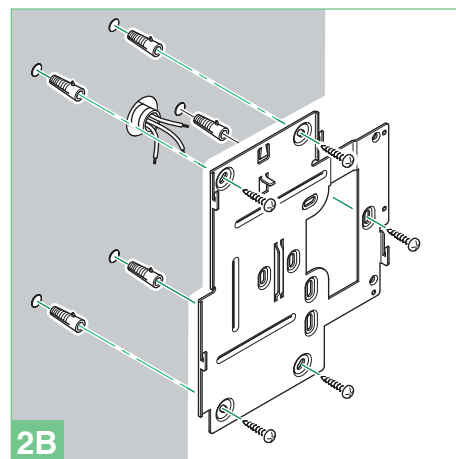

2B

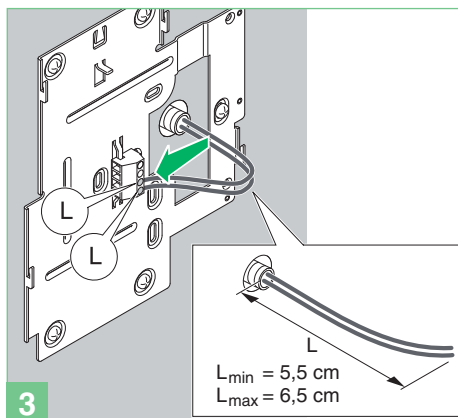

3

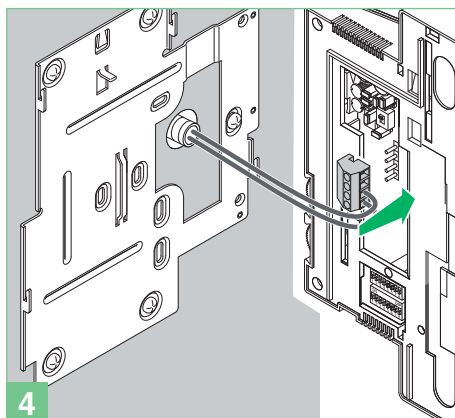

4

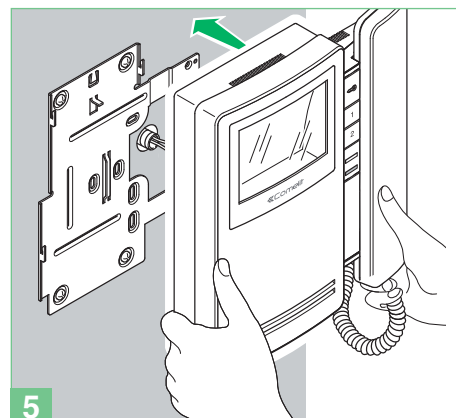

5

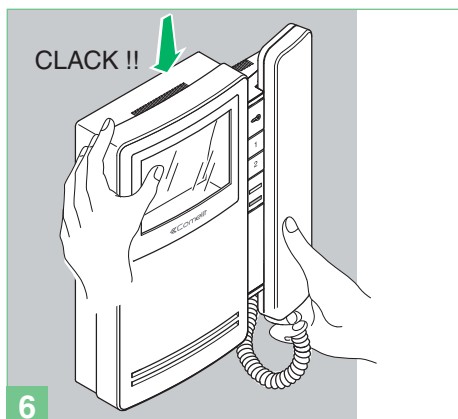

6

Retrait du moniteur

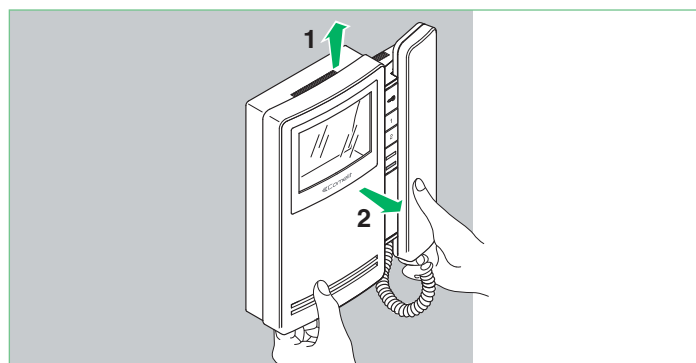

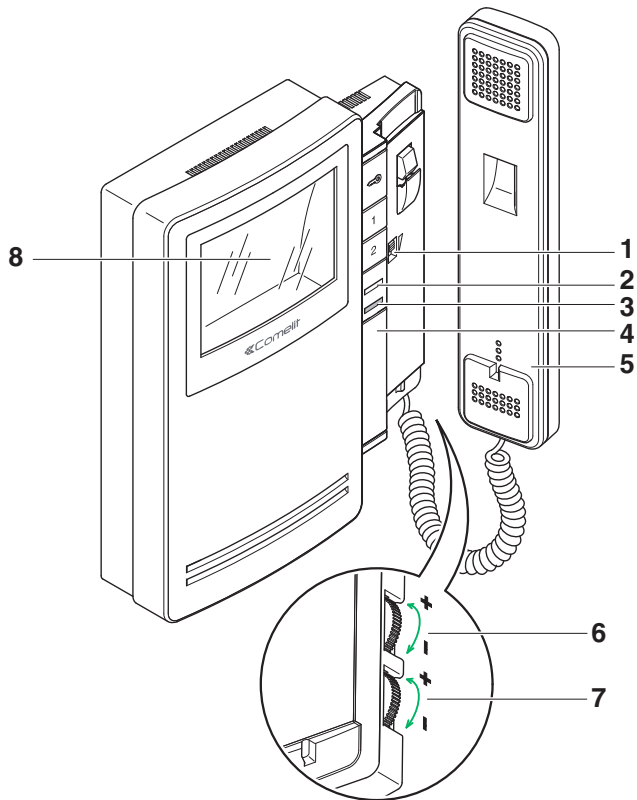

Description moniteur :

- 1 Réglage volume appel / sélecteur fonction Privé (par service Privé, on entend l'exclusion de l'appel depuis la plaque de rue et des combinés parlophoniques ou visiophones intercommunicants ; l'activation du service Privé est indiquée par l'apparition d'un indicateur rouge à côté du sélecteur).
- 2 Led de signalisation installation occupée/fonction docteur ON/porte ouverte.
- 3 Témoïn rouge - privacy validée.
- 4 Espace logement boutons supplémentaires avec accessoire Art. 6333, Art. 6434.
- 5 Combiné Moniteur (soulever le combiné pour commencer la communication).
- 6 Bouton de réglage de l'intensité de la couleur.
 - ▶ Pour augmenter la valeur, tourner dans le sens inverse des aiguilles d'une montre.
- 7 Bouton de réglage de la luminosité.
 - ▶ Pour augmenter la valeur, tourner dans le sens inverse des aiguilles d'une montre.
- 8 Écran 3,5" couleurs.

Description boutons :

- ☞ Bouton ouvre-porte,
- 1 Touche 1 actionneur générique (programmable).
- 2 Touche 2 auto-allumage (programmable).

Description moniteur

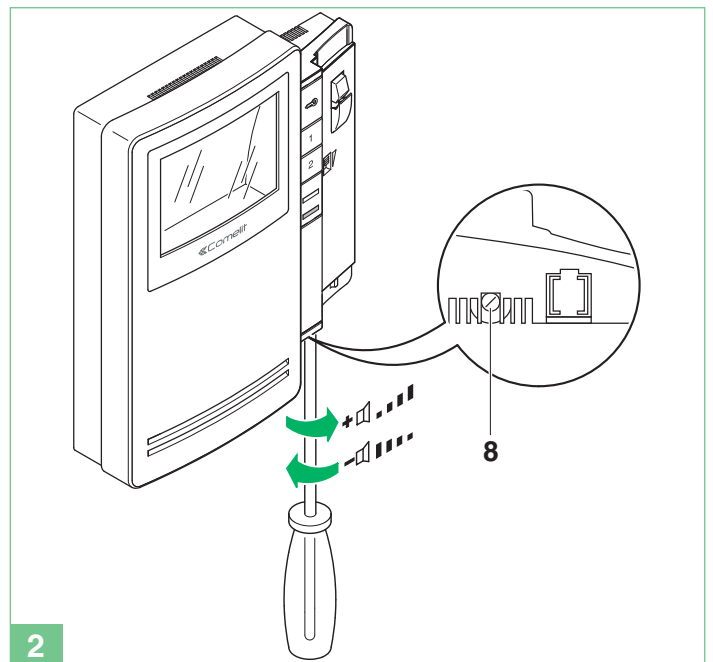
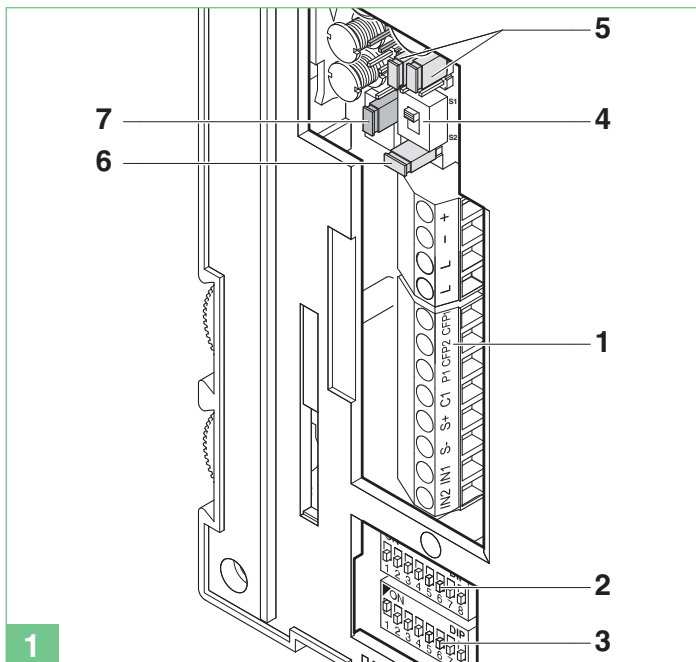

- 1 Bornier pour la connexion de l'installation :
 - + - Bornes pour alimentation.
 - L L Bornes de connexion ligne Bus.
 - CFP1 CFP2 Entrée de l'appel palier.
 - P1 C1 Bornes bouton 1 pour services divers.
 - Pour avoir un contact C.NO. (24V-100mA maxi), déplacer les cavaliers CV3 et CV4 sur la position B.**
 - S+ S- Bornes pour le dispositif de répétition de l'appel.
 - IN1 IN2 Entrée LED (programmable).
- 2 S1 Microswitches pour la programmation du code utilisateur.
- 3 S2 DIP switches de programmation des boutons et fonctions (identifié par un coin rouge) :
 - DIP 1-2-3-4 de programmation des fonctions des boutons.
 - DIP 5-6 accès à la programmation.

- DIP 7 de gestion de la tension d'alimentation (voir schémas et variantes page 121) défaut = **OFF**.
- DIP 8:
 - ON étrier secondaire.
 - OFF étrier principal (défaut).
- 4 SW3 Sélecteur pour modalité Simplebus 1 (S1-défaut) ou Simplebus 2 (S2).
- 5 CV3 CV4 Cavalier pour libérer le bouton 1 (contact C.NO. 24V-100mA maxi).
 - A bouton 1 actionneur générique (par défaut) ou programmable.
 - B bouton 1 pour usages divers.
- 6 CV5 Cavalier débranchement.
- 7 CV6 sélecteur pour l'utilisation de l'entrée IN 1 (voir page 138).
- 8 Réglage du volume du haut-parleur (uniquement pour le réglage de la phonie d'intercommunication).

Art. 2608

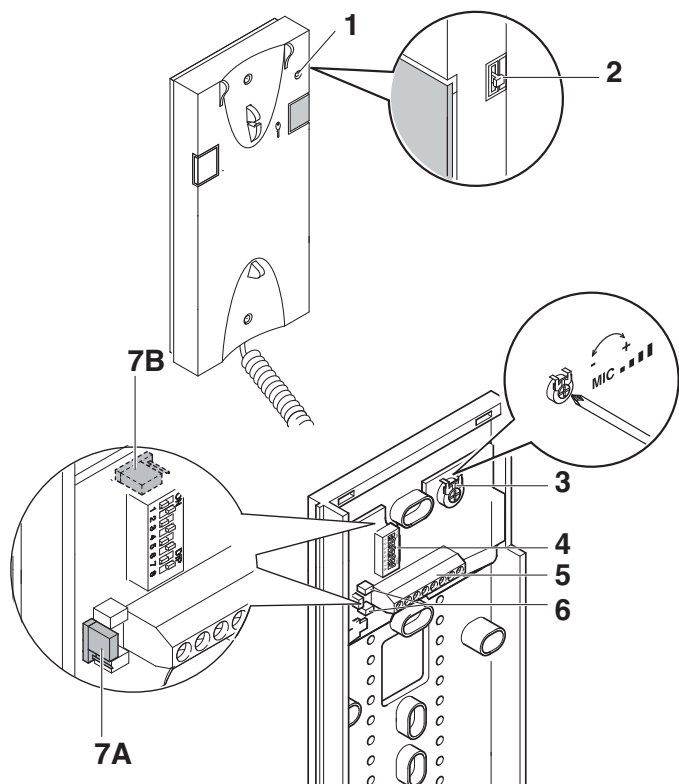

Non utilisable pour la fonction intercommunicante.

Le combiné parlophonique doit toujours être monté en utilisant l'Art. 1214/2C comme indiqué par le schéma de branchement MSK/FC page 136.

1 Voyant fonction Privacy.

2 Sélecteur sonnerie / service Privacy à 3 positions :

Position haute : Sonnerie volume maximum.

Position centrale : Sonnerie volume moyen.

Position basse : Activation fonction Privacy.

(Le Service Privé exclut l'appel du poste extérieur ou du standard de conciergerie ; l'activation de la fonction Privé est indiquée par l'apparition d'un voyant rouge en haut à droite).

3 Potentiomètre de réglage du volume du microphone.

4 Micro-interrupteurs pour programmation code usager.

5 Bornes pour le raccordement de l'installation :

L L Connexion à la ligne bus.

CFP CFP Entrée de l'appel palier.

P1 C1 Bornes bouton P1 pour services divers (contact C.NO, 24V-100mA max) (retirer CV1 et CV2, voir variante SB/X3 page 136).

S+ S- Bornes pour le dispositif de répétition de l'appel.

6 CV1 CV2 Cavalier à retirer pour avoir un contact libre C.NO. sur le bouton P1.

7A/7B JP1 cavalier pour sélectionner la fonction appel standard (position C)/Actionneur générique (position A) du bouton P1.

Description boutons :

☞ Bouton ouvre-porte.

P1 Bouton P1 appel standard/actionneur générique/bouton pour usages divers présent en bornier (P1 C1).

Nettoyer avec un chiffon humidifié avec de l'eau. Éviter d'utiliser de l'alcool ou d'autres produits agressifs.

FR

Installation combiné parlophonique Art. 2608

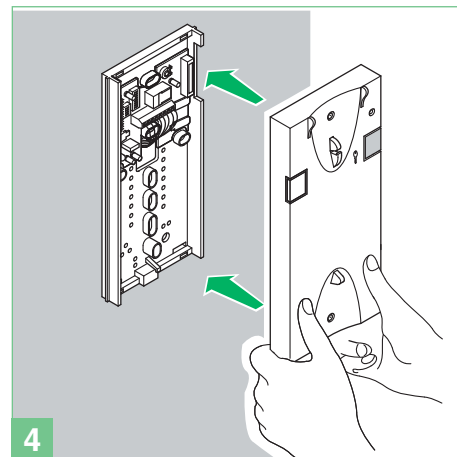
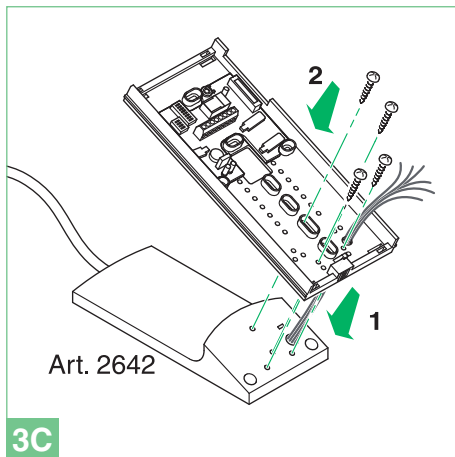
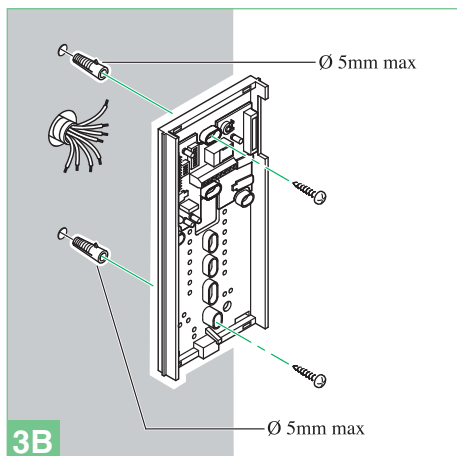
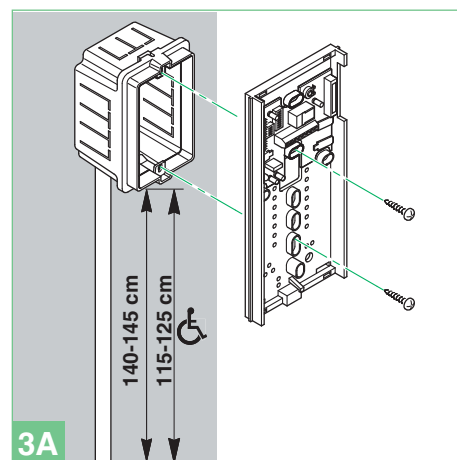
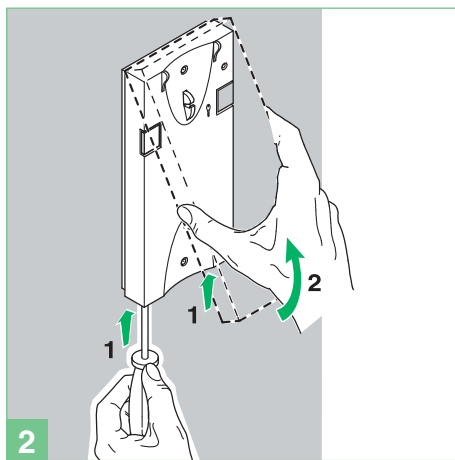
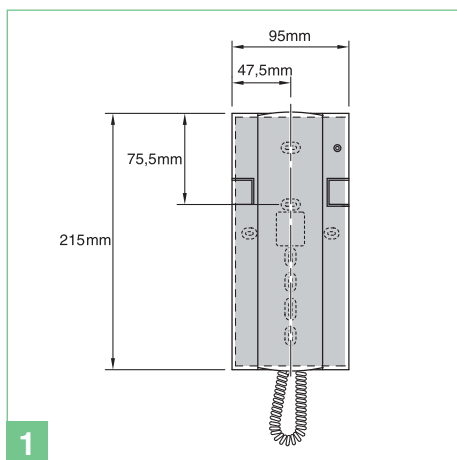

Indications générales d'installation et fonctionnement

La distance maximum totale entre le poste extérieur et le moniteur le plus éloigné est de 400 m (avec amplificateur Réf. 4833C).

La somme du nombre de postes intérieurs ayant le même code usager et du nombre de dispositifs de répétition d'appel branchés à ces postes intérieurs ne peut pas être supérieure à 4.

Brancher un seul dispositif de répétition d'appel pour chaque poste intérieur.

La distance MAX de la connexion entre le poste intérieur et le dispositif de répétition d'appel est de 20m ; pour la connexion, utiliser un câble blindé et ne pas faire passer les câbles à proximité de charges inductives lourdes ou de câbles d'alimentation (230V / 400V).

Tableau distances de fonctionnement

		A/G MAX	B/E MAX	C MAX	D MAX	F MAX	Art. 1216
Comelit Art. 4577	1 mm ² (Ø 1,2 mm AWG 17) 	50 m (165 feet)	50 m (165 feet)	200 m (655 feet)	100 m (330 feet)	150 m (495 feet)	
Comelit Art. 4576-4578	0,5 mm ² (Ø 0,8 mm AWG 20) bus 		25 m (85 feet)	200 m (655 feet)	100 m (330 feet)	150 m (495 feet)	
	1,5 mm ² (Ø 1,4 mm AWG 15) power 	75 m (245 feet)	100 m (330 feet)				
UTP5 cat. 5	0,2 mm ² (Ø 0,6 mm AWG 24) 			190 m (625feet)	60 m (195 feet)	150 m (495 feet)	
	0,28 mm ² (Ø 0,6 mm AWG 23) 	5 m (15 feet)		190 m (625 feet)	60 m (195 feet)	150 m (495 feet)	
	0,5 mm ² (Ø 0,8 mm AWG 20) 	25 m (85 feet)	25 m (85 feet)	190 m (625 feet)	60 m (195 feet)	150 m (495 feet)	
	1 mm ² (Ø 1,2 mm AWG 17) 	50 m (165 feet)	50 m (165 feet)	190 m (625 feet)	60 m (195 feet)	150 m (495 feet)	
	1 mm ² (Ø 1,2 mm AWG 17) 	50 m (165 feet)	50 m (165 feet)	120 m (395 feet)	40 m (130 feet)	100 m (330 feet)	
	1,5 mm ² (Ø 1,4 mm AWG 15) 	75 m (245 feet)	100 m (330 feet)	190 m (625 feet)	60 m (195 feet)	150 m (495 feet)	
	2,5 mm ² (Ø 1,8 mm AWG 13) 	100 m (330 feet)	150 m (495 feet)	190 m (625 feet)	60 m (195 feet)	150 m (495 feet)	

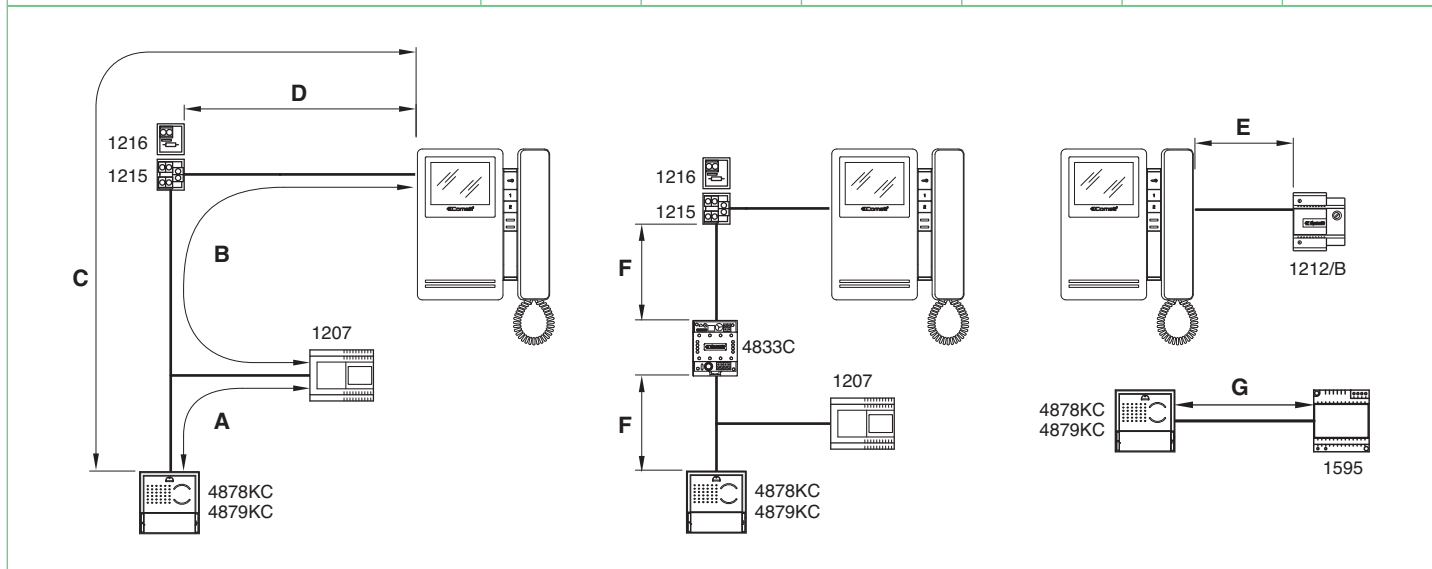

Fonctionnement



En cas de court-circuit persistant sur la ligne bus, le poste extérieur émet un signal sonore intermittent d'avertissement.

Lorsque le visiteur appuie sur le bouton d'appel, les leds blanches s'allument pour éclairer la personne, la sonnerie interne d'appel s'enclenche (si la fonction privé n'est pas validée) et l'image s'affiche au moniteur principal ou aux moniteurs principaux, pendant environ 60".

La durée maximum de la conversation entre poste extérieur et poste intérieur est de 90".

Sur le poste extérieur on a une tonalité d'appel ; lorsque, dans les installations à 2 entrées ou plus, au moment de l'appel le poste extérieur émet une tonalité d'occupé au lieu de la sonnerie, cela signifie qu'une autre conversation est en cours vers un autre poste extérieur.

Pour la programmation d'adresses usagers différentes de celles programmées d'origine (1 et 2), voir page 43.

Pour les fonctions d'intercommunication du système Magis KIT, voir la page 46.

Description programmations et fonctions boutons

Réglage du moniteur Réf. 6402E et du combiné parlophonique Style

Position des dip-switches du moniteur Réf. 6402E

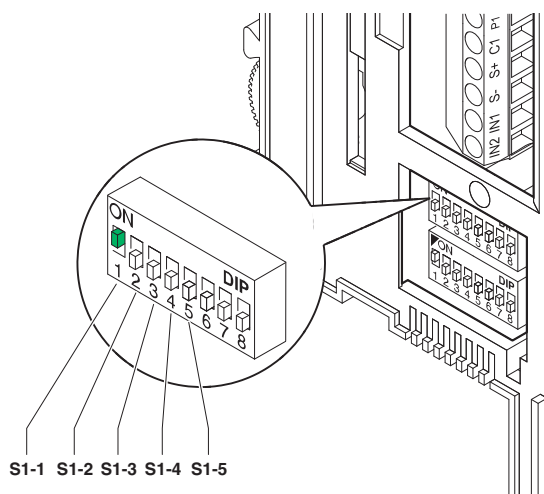

► Sur les combinés parlophoniques Art. 2608, Art. 2610 et Art. 2628 placer les dips **S1-6, S1-7, S1-8** sur **OFF**.

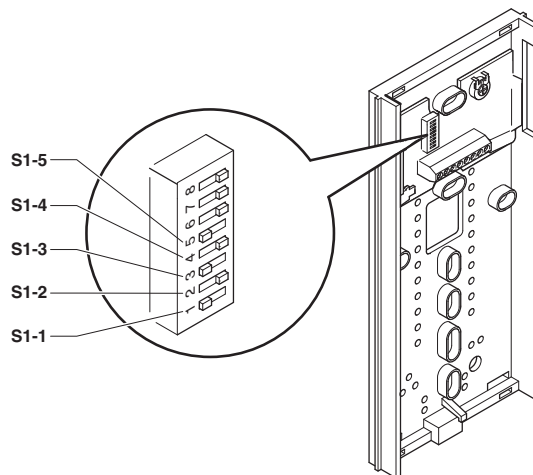

Les valeurs de **S1-1, S1-2, S1-3, S1-4** et **S1-5** définissent l'**adresse d'appel** du moniteur et des combinés parlophoniques, comme indiqué dans le tableau ci-après.

TAB. A Adresse de montant

Code	S1	Code	S1	Code	S1	Code	S1
1		9		17		25	
2		10		18		26	
3		11		19		27	
4		12		20		28	
5		13		21		29	
6		14		22		30	
7		15		23			
8		16		24			

Description fonctions

L'appel intercommunicant deux usagers (entre les combinés parlophoniques et/ou les moniteurs visiophoniques) n'est possible que si les deux usagers sont réglés sur des codes d'appel contigus (marqués par la même lettre AA..CC..OO dans le tableau de programmation des DIP switches illustré page 43).

🔑 **Ouvre-porte** : La pression du bouton Ouvre-porte active la serrure reliée à la plaque de rue.

Actionneur : La pression du Bouton 1 programmé dans la modalité Actionneur permet d'activer l'Art. 1256 qui peut être utilisé par exemple pour activer l'ouverture de portails, portes basculantes ou pour l'activation du module caméras cycliques Art. 1259C.

Bouton Libre : L'indication Bouton libre indique la possibilité d'utiliser le bouton comme contact C.NO en bornier au moyen de programmations opportunes comme illustré dans la variante SB2/AAM2 pag. 139.

Autoallumage/demande vidéo

L'auto-allumage peut être invalidé.

L'auto-allumage n'est possible que lorsque l'installation est en veille.

Conseillé uniquement pour les installations avec 1 ou 2 entrées.

La pression du bouton 2 dans cette modalité permet de visualiser sur l'écran du moniteur l'image transmise depuis le poste extérieur même si aucun appel n'a été effectué.

Dans les installations équipées de 2 postes externes, il est possible de visualiser alternativement l'image depuis un poste extérieur ou depuis l'autre (fonction "basculer") en appuyant plusieurs fois sur le bouton 2.

Sur moniteurs secondaires (DIP 8 de S2 sur ON) le bouton 2 a également la fonction de demande vidéo, qui permet d'allumer un moniteur suite à un appel de poste extérieur.

Activation :

- appuyer le bouton dédié à l'auto-allumage du moniteur pendant un temps dépassant 4 sec.
- » sonnerie de confirmation.

Désactivation :

- appuyer le bouton dédié à l'auto-allumage du moniteur pendant un temps dépassant 4 sec.
- » 4 tonalités de confirmation.

Allumage :

- appuyer sur le bouton 2 et le relâcher immédiatement (si les programmations faites à l'usine ont été maintenues).

Appel au standard

Appuyer sur le bouton réglé sur cette modalité pour envoyer un appel au standard de conciergerie de l'installation.

Appel intercommunicant un usager

Cette fonction permet d'envoyer un appel aux autres appareils (moniteurs visiophoniques et/ou combinés parlophoniques) programmés sur la même adresse d'appel.

- En saisissant le combiné, le destinataire de l'appel engage la communication avec l'appelant. La communication prend fin lorsque le combiné est raccroché.

Un appel intercommunicant n'est pas prioritaire sur une conversation/un appel avec le poste extérieur.

Dans ce cas, lors d'une tentative d'appel intercommunicant, la led clignote pendant quelques secondes pour indiquer que le système est occupé.

Appel depuis le poste extérieur

Un appel provenant d'un poste extérieur est toujours prioritaire sur une communication intercommunicante (l'activation de la communication avec le poste extérieur interrompt la conversation intercom en cours).

Dans ce cas, les utilisateurs déjà en communication entendent dans le combiné un signal sonore similaire à un signal d'appel si ce dernier leur est destiné, ou un triple signal sonore dans le cas contraire.

- Pour prendre l'appel provenant du poste extérieur, il suffit de saisir le combiné d'une unité disponible ou de raccrocher, puis de saisir le combiné d'une unité occupée par une communication intercommunicante.

Docteur

Cette fonction permet d'actionner automatiquement l'ouvre-porte sur appel extérieur à l'adresse du poste intérieur sur lequel la fonction a été activée.

Validation / Invalidation :

- appuyer pendant 2 sec.le bouton spécifique de cette fonction.
- » Lorsque la fonction est active, la led de signalisation reste allumée.

FR

Moniteurs supplémentaires principaux ou secondaires

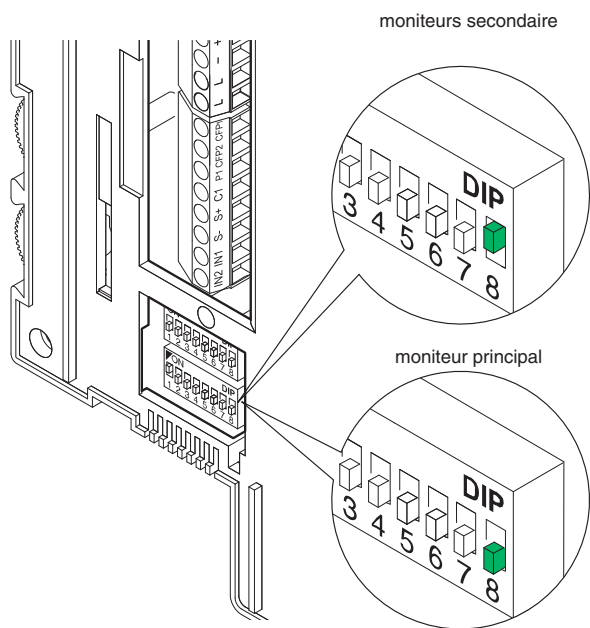

La programmation du DIP 8 de S2 définit si la bride en objet sera gérée comme principale (P) ou comme secondaire (S).

Le poste extérieur peut gérer jusqu'à un maximum de 4 visiophones ou parlophones par bouton d'appel.

Dans la configuration classique de Magis KIT, on peut donc avoir au maximum 2 visiophones principaux et 2 visiophones secondaire par bouton d'appel, tous alimentés par le même **Art.1207**.

On a la possibilité de gérer jusqu'à 3 visiophones principaux au sein de la même unité familiale (c'est-à-dire programmés sur le même code usager). Dans cette configuration particulière, les visiophones principaux supplémentaires devront être alimentés chacun par l'**Art. 1212/B** (voir variante MSK/HCA, MSK/IC page. 132, 133).

Lorsque l'on effectue un appel depuis le poste extérieur, le moniteur que le système allumera sera celui du visiophone principal.

Les autres moniteurs secondaires de la même unité familiale resteront éteints.

En répondant à l'appel du poste extérieur depuis un moniteur visiophonique secondaire, l'image est automatiquement visualisée sur le moniteur.

À ce stade, le moniteur visiophonique principal s'éteint et l'image s'affiche au moniteur visiophonique sur lequel on a appuyé sur le bouton 2 - auto-allumage/demande vidéo.

Pour visualiser l'image sans activer la phonie avec le poste extérieur, appuyer sur le bouton 2 - auto-allumage/demande vidéo.

Utilisation du kit sur les installations avec porte principale

Les schémas MSK/EN/109IC, MSK/EN/110IC pages 128, 131 montrent une configuration possible d'installation qui offre la possibilité de gérer jusqu'à un maximum de 30 Magis Kit de la part d'un Art. 4680C - Art. 4680KC* situé, par exemple, à l'entrée d'un complexe résidentiel.

L'utilisation de ces schémas d'installation permet d'appeler un des Magis kit de la plaque de rue principale, intégrant l'Art. 4680C - Art. 4680KC* .

Dans cette configuration, il est nécessaire de programmer les boutons de l'Art. 4680KC embarqué sur l'Art. 4879KC comme décrit dans la procédure suivante et les postes intérieurs avec le code correspondant, voir table page 43.

Pour plus de détails sur l'intégration des Magis Kit dans des installations Simplebus et pour la programmation de la porte principale (Art. 4680C - Art. 4680KC*), se référer au catalogue (Catalogue n°140) et au manuel technique z

* Limitations utilisation Art. 4680KC

L'Art. 4680KC gère les appels provenant des modules à boutons ou numériques, **UNIQUEMENT** s'ils sont compris entre l'adresse 1 et l'adresse 10.

Programmation Art. 4680KC

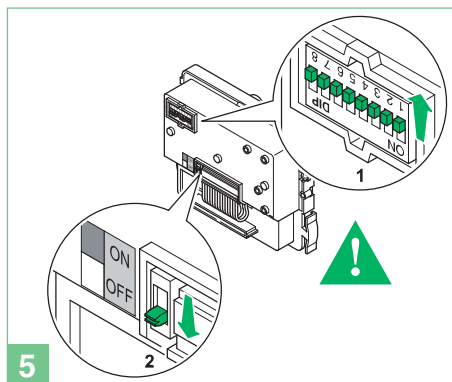
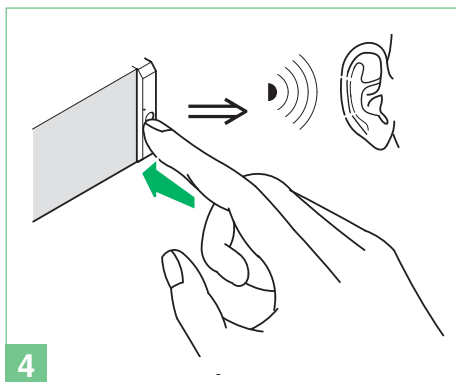
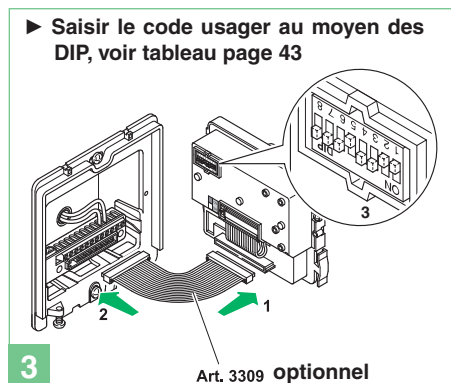
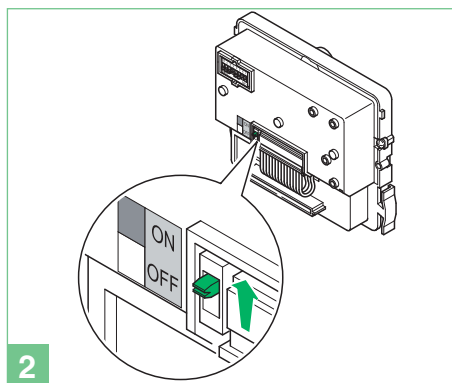
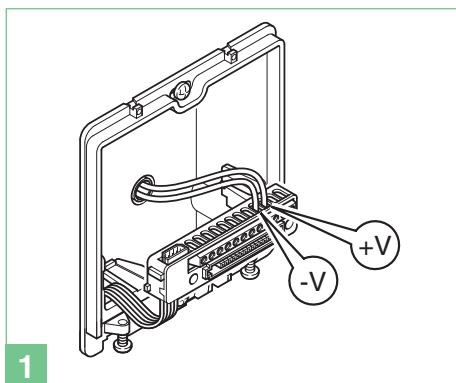

FR

Configuration des boutons par défaut

DIP S2				avec Art. 6433, 6434							
DIP 1	DIP 2	DIP 3	DIP 4	P1	P2			P3	P4	P5	P6
0	0	0	0	CCS	AI			ACT	D	PAN	K
1	0	0	0	ACT	AI			INT	INTb	D	CCS
0	1	0	0	INT	AI			INTb	ACT	CCS	CCP
1	1	0	0	ACT	CCS			CCP	PAN	K	D
0	0	1	0	ACT	ACT	ACT		ACT	ACT	ACT	ACT
1	0	1	0	INT	ACT			CCS	CCP	INTb	PAN
0	1	1	0	AI	D			K	CCS	CCP	INTb
1	1	1	0	INTb	INT			AI	INT	PAN	D
0	0	0	1	CCS	PAN			D	AI	INT	INTb
1	0	0	1	K	CCS			PAN	CCP	AI	INT
0	1	0	1	CCP	K			PAN	ACT	INT	AI
1	1	0	1	PAN	CCP			CCS	K	ACT	D
0	0	1	1	D	INTb			INT	ACT	AI	CCS
1	0	1	1	INT	INT			INT	INT	INT	INT
0	1	1	1	NULL	NULL	NULL	NULL	NULL	NULL	NULL	NULL
1	1	1	1						PROG		

Légende

	Ouvre-porte	CCS	Appel standard	INTb	intercommunicant deux usagers - uniquement pour KIT
	Phonie	K	Appel combiné parlophonique gardien	NULL	Aucune fonction
ACT	Actionneur	D	Docteur	PROG	Fonctions programmées, voir pages 45-46-47-48. Dans cette modalité des dip switches les boutons gèrent les fonctions programmées ; les boutons NON programmés commandent les fonctions signalées à la ligne 0000
AI	Auto-allumage	PAN	Panique		
CCP	Appel standard principal	INT	Intercommunicant programmable, général ou sélecteur - de série appel un usager pour KIT et Simplebus Top		



Recommandations générales pour la programmation des boutons

Au cas où les configurations par défaut (voir tableau page 45) ne répondraient pas à vos besoins, vous pouvez modifier la programmation des boutons en suivant les procédures décrites ci-après.

Une fois la procédure terminée, placer les DIP 1-2-3-4 de S2 en combinaison 1111 (réglage PROG dans les tableaux de configuration page 45-46-47-48). Lorsque les dip sont ainsi configurés, les boutons

gouvernent les fonctions programmées ; les boutons NON programmés commandent les fonctions signalées à la ligne 0000 (voir tableau page 45). Rétablir sur S1 la configuration du code usager, voir tableau A page 43.

Programmation des boutons pour actionneur générique ou particulier

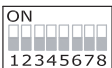
DIP S2								avec Art. 6433, 6434				DIP S1
DIP 1	DIP 2	DIP 3	DIP 4	P1	P2	☞	☎	P3	P4	P5	P6	ADRESSE 
0	0	0	0					ACT				
1	0	0	0	ACT		☞						
0	1	0	0			☞			ACT			
1	1	0	0	ACT								
0	0	1	0	ACT	ACT	ACT		ACT	ACT	ACT	ACT	
1	0	1	0		ACT							
0	1	1	0				☎					
1	1	1	0									
0	0	0	1									
1	0	0	1			☞						
0	1	0	1						ACT			
1	1	0	1							ACT		
0	0	1	1						ACT			
1	0	1	1									
0	1	1	1									
1	1	1	1									

Exemple :

sur moniteur avec code usager 5 programmation P1= actionneur générique, P2= actionneur particulier avec code 125.

1. Placer DIP 5-6 de S2 en combinaison 01.

» la Led (verte) clignote.

2. Consulter le tableau page 46 et choisir une combinaison qui affiche la fonction actionneur (ACT) pour les boutons qui doivent être programmés.

ex : pour P1= actionneur générique, programmer DIP 1-2-3-4 de S2 en combinaison 1000 ou 1100 ou 0010 (P1=ACT), programmer DIP de S1 en combinaison 11111111, passer au point 3.

ex : pour P2= actionneur particulier avec code 125, programmer DIP 1-2-3-4 de S2 en combinaison 0010 ou 1010 (P2=ACT), programmer S1 avec adresse 125 conformément au **tableau C** page 48, passer au point 3.

3. Appuyer sur le bouton puis le relâcher pour associer la fonction.

» la Led (verte) s'allume.

» tonalité de confirmation dans le combiné.

4. Pour quitter la programmation, mettre les DIP 5-6 de S2 en combinaison 00

» la Led (verte) s'éteint.



5. Au terme de la programmation, mettre les DIP 1-2-3-4 de S2 en combinaison 1111. Rétablir sur S1 la configuration du code usager, voir **tableau C** page 48.

Programmation pour appel intercommunicant



Appel intercommunicant général et sélecteur **NE SONT PAS** compatibles sur le même montant.

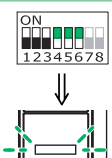
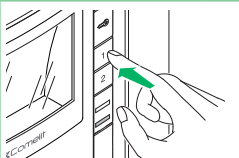
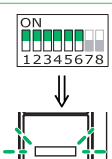







Programmation/effacement adresse intercommunicant (uniquement pour l'appel intercommunicant sélecteur)

	! 2)						3)	
S1	DIP 1	DIP 2	DIP 3	DIP 4	DIP 5	DIP 6	S2	
Programmation; programmer code, TAB. B page 46	0	0	0	1	1	1		
Effacement	1	1	1	1	1	1		



Prendre note de la configuration de **S2, S1** et la rétablir à la fin de la programmation.

TAB. B Adresses intercommunicant sélecteur

Code	Dip switch ON	S1	Code	Dip switch ON	S1	Code	Dip switch ON	S1
1	1		4	4		7	7	
2	2		5	5		8	8	
3	3		6	6				

Il est nécessaire de programmer l'adresse intercommunicante sur tous les postes intérieurs de la colonne montante.

Il est possible d'associer la même adresse intercommunicante à 3 postes intérieurs maximum.

Pour un appel de groupe sélectionner simultanément les codes intercommunicants voulus(max 3).

Programmation des boutons pour appel intercommunicant

DIP S2								avec Art. 6433, 6434				DIP S1	
DIP 1	DIP 2	DIP 3	DIP 4	P1	P2			P3	P4	P5	P6	ADRESSE 	
0	0	0	0										
1	0	0	0					INT	INTb				
0	1	0	0	INT				INTb					
1	1	0	0										
0	0	1	0										
1	0	1	0	INT						INTb			
0	1	1	0								INTb		
1	1	1	0	INTb	INT				INT				
0	0	0	1							INT	INTb		
1	0	0	1								INT		INT
0	1	0	1							INT			
1	1	0	1										
0	0	1	1		INTb			INT					
1	0	1	1	INT	INT			INT	INT	INT	INT		
0	1	1	1										
1	1	1	1										
PROG													

Exemple 1 - Intercommunicant sélecteur

sur moniteur avec code usager 1 et adresse intercommunicant 1
programmation P3= intercommunicant sélecteur avec adresse 2, P4= intercommunicant sélecteur avec adresse 3.

Exemple 2 - KIT intercommunicant

(intercommunicant entre 2 adresses contiguës dans la plage de 1 à 30 dont la première est impaire) :

sur moniteur avec code usager 1 programmation P3= appel général interne, P4= intercommunicant 2 usagers avec adresse 2.

1. Placer DIP 5-6 de S2 en combinaison 01.

» la Led (verte) clignote.

2. Consulter le tableau page 47 et choisir une combinaison qui affiche la fonction appel intercommunicant (INT ou INTb) pour les boutons qui doivent être programmés.

ex 1 : pour P3= intercommunicant sélecteur, programmer DIP 1-2-3-4 de S2 en combinaison 1000 ou 0011 ou 1011 (P3=INT), programmer S1 avec adresse 2 conformément au **tableau B** page 46, passer au point 3.

ex 1 : pour P4= intercommunicant sélecteur, programmer DIP 1-2-3-4 de S2 en combinaison 1110 ou 1011 (P4=INT), programmer S1 avec adresse 3 conformément au **tableau B** page 46, passer au point 3.

ex 2 : pour P3= appel général interne et P4=intercommunicant 2 usagers, programmer DIP 1-2-3-4 de S2 en combinaison 1000 (P3=INT, P4=INTb), programmer S1 avec code usager 1 conformément au **tableau A** page 43, passer au point 3.

3. Appuyer sur le bouton puis le relâcher pour associer la fonction.

» la Led (verte) s'allume.

» tonalité de confirmation dans le combiné.

4. Pour quitter la programmation, mettre les DIP 5-6 de S2 en combinaison 00.

» la Led (verte) s'éteint.

5. Au terme de la programmation, mettre les DIP 1-2-3-4 de S2 en combinaison 1111. Rétablir sur S1 la configuration du code usager, voir **tableau A** page 43.

Programmation des boutons pour d'autres fonctions

DIP S2								avec Art. 6433, 6434			
DIP 1	DIP 2	DIP 3	DIP 4	P1	P2			P3	P4	P5	P6
0	0	0	0	CCS	AI				D	PAN	K
1	0	0	0		AI					D	CCS
0	1	0	0		AI					CCS	CCP
1	1	0	0		CCS			CCP	PAN	K	D
0	0	1	0								
1	0	1	0								
0	1	1	0	AI	D			CCS	CCP		PAN
1	1	1	0					K	CCS	CCP	D
0	0	0	1	CCS	PAN			AI			
1	0	0	1	K	CCS			PAN	CCP	AI	
0	1	0	1	CCP	K			PAN			AI
1	1	0	1	PAN	CCP			CCS	K		D
0	0	1	1	D						AI	CCS
1	0	1	1								
0	1	1	1	NULL	NULL	NULL	NULL	NULL	NULL	NULL	NULL
PROG											

Légende

	Ouvre-porte	CCS	Appel standard	NULL	Aucune fonction
	Phonie	K	Appel combiné parlophonique gardien	PROG	Fonctions programmées
AI	Auto-allumage	D	Docteur		
CCP	Appel standard principal	PAN	Panique		

Exemple :

sur moniteur avec code usager 5 programmation P5= auto-allumage, P6=appel au standard.

1. Placer DIP 5-6 de S2 en combinaison 01.

» la Led (verte) clignote.

2. Consulter le tableau page 47 et choisir une combinaison qui affiche les fonctions choisies/nécessaires pour les boutons qui doivent être programmés.

ex : pour P5= auto-allumage P6= appel au standard, programmer DIP 1-2-3-4 de S2 en combinaison 0011 (P5=AI, P6=CCS).

3. Appuyer sur le bouton puis le relâcher pour associer la fonction.

» la Led (verte) s'allume.

» tonalité de confirmation dans le combiné.

4. Pour quitter la programmation, mettre les DIP 5-6 de S2 en combinaison 00.

» la Led (verte) s'éteint.

5. Au terme de la programmation, mettre les DIP 1-2-3-4 de S2 en combinaison 1111.

TAB. C Adresse de montant

Code	Dip switch ON	Code	Dip switch ON	Code	Dip switch ON	Code	Dip switch ON	Code	Dip switch ON	Code	Dip switch ON	Code	Dip switch ON	Code	Dip switch ON
1	1	31	1,2,3,4,5	61	1,3,4,5,6	91	1,2,4,5,7	121	1,4,5,6,7	151	1,2,3,5,8	181	1,3,5,6,8	211	1,2,5,7,8
2	2	32	6	62	2,3,4,5,6	92	3,4,5,7	122	2,4,5,6,7	152	4,5,8	182	2,3,5,6,8	212	3,5,7,8
3	1,2	33	1,6	63	1,2,3,4,5,6	93	1,3,4,5,7	123	1,2,4,5,6,7	153	1,4,5,8	183	1,2,3,5,6,8	213	1,3,5,7,8
4	3	34	2,6	64	7	94	2,3,4,5,7	124	3,4,5,6,7	154	2,4,5,8	184	4,5,6,8	214	2,3,5,7,8
5	1,3	35	1,2,6	65	1,7	95	1,2,3,4,5,7	125	1,3,4,5,6,7	155	1,2,4,5,8	185	1,4,5,6,8	215	1,2,3,5,7,8
6	2,3	36	3,6	66	2,7	96	6,7	126	2,3,4,5,6,7	156	3,4,5,8	186	2,4,5,6,8	216	4,5,7,8
7	1,2,3	37	1,3,6	67	1,2,7	97	1,6,7	127	1,2,3,4,5,6,7	157	1,3,4,5,8	187	1,2,4,5,6,8	217	1,4,5,7,8
8	4	38	2,3,6	68	3,7	98	2,6,7	128	8	158	2,3,4,5,8	188	3,4,5,6,8	218	2,4,5,7,8
9	1,4	39	1,2,3,6	69	1,3,7	99	1,2,6,7	129	1,8	159	1,2,3,4,5,8	189	1,3,4,5,6,8	219	1,2,4,5,7,8
10	2,4	40	4,6	70	2,3,7	100	3,6,7	130	2,8	160	6,8	190	2,3,4,5,6,8	220	3,4,5,7,8
11	1,2,4	41	1,4,6	71	1,2,3,7	101	1,3,6,7	131	1,2,8	161	1,6,8	191	1,2,3,4,5,6,8	221	1,3,4,5,7,8
12	3,4	42	2,4,6	72	4,7	102	2,3,6,7	132	3,8	162	2,6,8	192	7,8	222	2,3,4,5,7,8
13	1,3,4	43	1,2,4,6	73	1,4,7	103	1,2,3,6,7	133	1,3,8	163	1,2,6,8	193	1,7,8	223	1,2,3,4,5,7,8
14	2,3,4	44	3,4,6	74	2,4,7	104	4,6,7	134	2,3,8	164	3,6,8	194	2,7,8	224	6,7,8
15	1,2,3,4	45	1,3,4,6	75	1,2,4,7	105	1,4,6,7	135	1,2,3,8	165	1,3,6,8	195	1,2,7,8	225	1,6,7,8
16	5	46	2,3,4,6	76	3,4,7	106	2,4,6,7	136	4,8	166	2,3,6,8	196	3,7,8	226	2,6,7,8
17	1,5	47	1,2,3,4,6	77	1,3,4,7	107	1,2,4,6,7	137	1,4,8	167	1,2,3,6,8	197	1,3,7,8	227	1,2,6,7,8
18	2,5	48	5,6	78	2,3,4,7	108	3,4,6,7	138	2,4,8	168	4,6,8	198	2,3,7,8	228	3,6,7,8
19	1,2,5	49	1,5,6	79	1,2,3,4,7	109	1,3,4,6,7	139	1,2,4,8	169	1,4,6,8	199	1,2,3,7,8	229	1,3,6,7,8
20	3,5	50	2,5,6	80	5,7	110	2,3,4,6,7	140	3,4,8	170	2,4,6,8	200	4,7,8	230	2,3,6,7,8
21	1,3,5	51	1,2,5,6	81	1,5,7	111	1,2,3,4,6,7	141	1,3,4,8	171	1,2,4,6,8	201	1,4,7,8	231	1,2,3,6,7,8
22	2,3,5	52	3,5,6	82	2,5,7	112	5,6,7	142	2,3,4,8	172	3,4,6,8	202	2,4,7,8	232	4,6,7,8
23	1,2,3,5	53	1,3,5,6	83	1,2,5,7	113	1,5,6,7	143	1,2,3,4,8	173	1,3,4,6,8	203	1,2,4,7,8	233	1,4,6,7,8
24	4,5	54	2,3,5,6	84	3,5,7	114	2,5,6,7	144	5,8	174	2,3,4,6,8	204	3,4,7,8	234	2,4,6,7,8
25	1,4,5	55	1,2,3,5,6	85	1,3,5,7	115	1,2,5,6,7	145	1,5,8	175	1,2,3,4,6,8	205	1,3,4,7,8	235	1,2,4,6,7,8
26	2,4,5	56	4,5,6	86	2,3,5,7	116	3,5,6,7	146	2,5,8	176	5,6,8	206	2,3,4,7,8	236	3,4,6,7,8
27	1,2,4,5	57	1,4,5,6	87	1,2,3,5,7	117	1,3,5,6,7	147	1,2,5,8	177	1,5,6,8	207	1,2,3,4,7,8	237	1,3,4,6,7,8
28	3,4,5	58	2,4,5,6	88	4,5,7	118	2,3,5,6,7	148	3,5,8	178	2,5,6,8	208	5,7,8	238	2,3,4,6,7,8
29	1,3,4,5	59	1,2,4,5,6	89	1,4,5,7	119	1,2,3,5,6,7	149	1,3,5,8	179	1,2,5,6,8	209	1,5,7,8	239	1,2,3,4,6,7,8
30	2,3,4,5	60	3,4,5,6	90	2,4,5,7	120	4,5,6,7	150	2,3,5,8	180	3,5,6,8	210	2,5,7,8	*240	5,6,7,8

*REMARQUE : le code 240 est réservé au standard de conciergerie

Reset de programmation

1)	2)						3)		4)	
S1	DIP 1	DIP 2	DIP 3	DIP 4	DIP 5	DIP 6	S2	S1/S2/LED1		
	1	1	1	1	1	1				Prendre note de la configuration de S2, S1 et la rétablir à la fin de la programmation.
Configurations d'usine : <ul style="list-style-type: none"> Fonctions des boutons selon la combinaison DIP 1-2-3-4 de S2 ; Adresse intercommunicant absente ; Fonction range et adresses mini et maxi absentes ; Reset sonneries ; Entrée IN 1 ⇒ LED (défaut). 										

Effectuer les opérations de 1 à 4

Programmation range/sonneries

1)

2)

3)

4)

S1

S2

DIP 1

DIP 2

DIP 3

DIP 4

DIP 5

DIP 6

S2

S1/S2/LED1

Adresse range minimum

programmer
code, **TAB. C**
page 48

Adresse range maximum

Validation range

Désactivation range

Sélection de la sonnerie polyphonique

Sélection de la sonnerie tonalités (défaut)

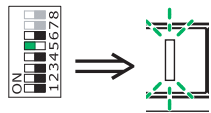
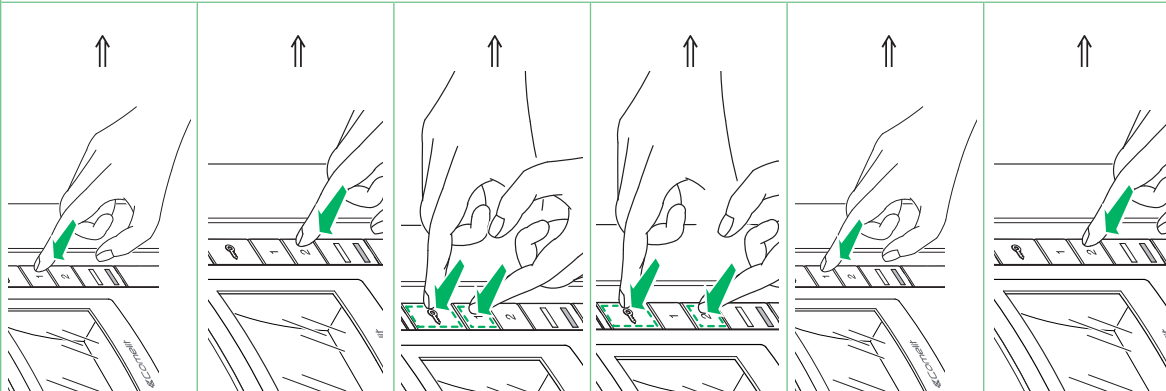

0

0

0

0

1

0

0

0

0

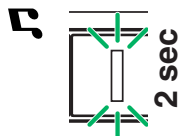

! Prendre note de la configuration de **S2**, **S1** et la rétablir à la fin de la programmation.

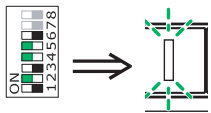
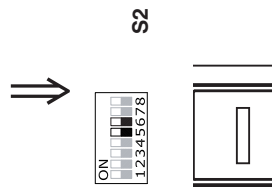

0

1

1

1

0

0

0

0

Effectuer les opérations de 1 à 4																				
		1)					2)					3)		4)						
		S1										S2		S1/S2/LED1						
		DIP 1	DIP 2	DIP 3	DIP 4	DIP 5	DIP 6													
<p>Programmation de l'entrée IN1 pour signal led/ alarme/ouvre-porte/actionneur</p>	<p>Entrée IN 1 ⇒ LED (défaut), voir pages 138</p>																			
	<p>Entrée IN 1 ⇒ ALARME, voir pages 138</p>	0	0	0	1	1	0													
	<p>Entrée IN 1 ⇒ OUVRE-PORTE, voir pages 138</p>																			
	<p>Entrée IN 1 ⇒ ACTIONNEUR PARTICULIER, voir pages 138</p>	0	0	1	0	1	0													
<p>Entrée IN 1 ⇒ ACTIONNEUR GÉNÉRIQUE, voir pages 138</p>																				

Prendre note de la configuration de S2, S1 et la rétablir à la fin de la programmation.

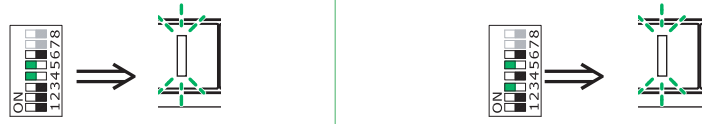
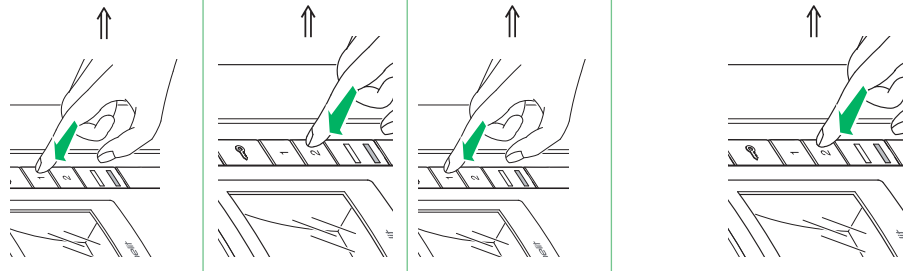
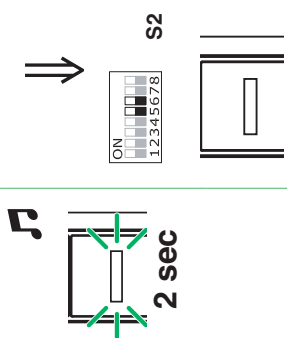

Programmation directe appel intercommunicant

Permet la programmation des appels intercommunicants directement depuis les postes intérieurs.

✓ Nécessite la présence de 2 opérateurs.

Phase 1 : entrée en programmation

L'opérateur 1 et l'opérateur 2 effectuent les opérations suivantes sur 2 postes intérieurs :

1. Configurer DIP 1-2-3-4 de S2 en combinaison 1111.

2. Décrocher le combiné.

3. Appuyer 3 secondes sur les touches 1 et 2 .

» *Le poste intérieur émet 1 tonalité.*

» *La Led verte clignote.*

» *Le poste intérieur se met en phonie.*

» *À ce stade, les 2 opérateurs sont en communication entre eux.*

Phase 2 : programmation appel intercommunicant

Opérateur 1 :

▶ Il appuie sur le bouton qu'il veut programmer pour appeler l'opérateur 2 (ex. 2).

» *Le poste intérieur de l'opérateur 1 émet une tonalité de confirmation.*

Opérateur 2 :

▶ Il appuie sur le bouton qu'il veut programmer pour appeler l'opérateur 1 (ex. 1).

» *Le poste intérieur de l'opérateur 2 émet une tonalité de confirmation.*

Opérateur 1/Opérateur 2 :

▶ Raccrocher le combiné.

» *Le poste intérieur émet 1 tonalité.*

» *La programmation des 2 postes intérieurs est terminée.*

Pour programmer un autre poste intérieur, passer à la PHASE 3.

Phase 3 : Programmation d'autres postes intérieurs



Opérateur 1/Opérateur 2 :

1. Une fois le nouveau poste atteint, il effectue la phase 1 pour entrer en communication.

2. Répéter la phase 2.

REMARQUE Si l'on reçoit un appel durant la programmation, il est nécessaire de répondre à l'appel puis de reprendre la phase de programmation.

Variation sonnerie moniteur

1. Maintenir appuyé le bouton  jusqu'à ce qu'une tonalité de confirmation soit audible (cette opération n'est possible que lorsque le système est en condition de repos ; dans le cas contraire, la led de signalisation clignote pour avertir l'utilisateur).
2. Appuyer et relâcher le bouton  :
 - 1 fois (émission d'une tonalité de confirmation) pour modifier la sonnerie d'appel depuis le poste extérieur.
 - 2 fois (émission de 2 tonalités de confirmation) pour modifier la sonnerie depuis standard.
 - 3 fois (émission de 3 tonalités de confirmation) pour modifier la sonnerie d'appel intercommunicant depuis un poste intérieur.
 - 4 fois (émission de 4 tonalités de confirmation) pour modifier la sonnerie de l'appel palier.Appuyer ultérieurement sur le bouton  pour répéter la séquence décrite ci-dessus.
3. Appuyer et relâcher le bouton 1 pour écouter les diverses sonneries disponibles l'une après l'autre.
4. Appuyer sur le bouton 2 pour confirmer la sélection de la dernière tonalité que vous avez entendue et pour quitter (à tout moment) le mode de sélection sonnerie moniteur. Une tonalité de confirmation vous avertira que vous avez quitté la modalité de variation de la sonnerie moniteur.

Programmations spéciales Art.4680KC

FR

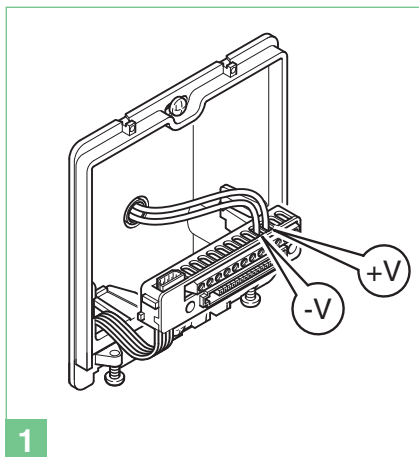

1

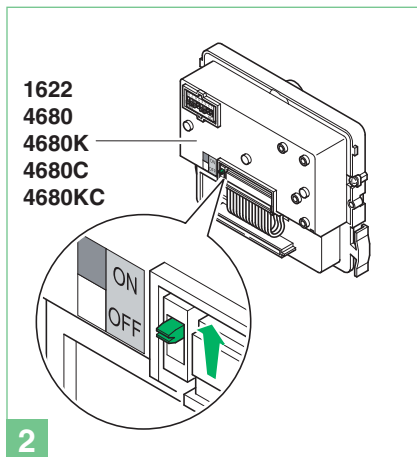

2

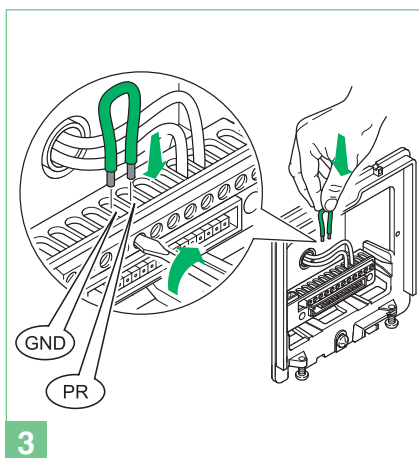

3

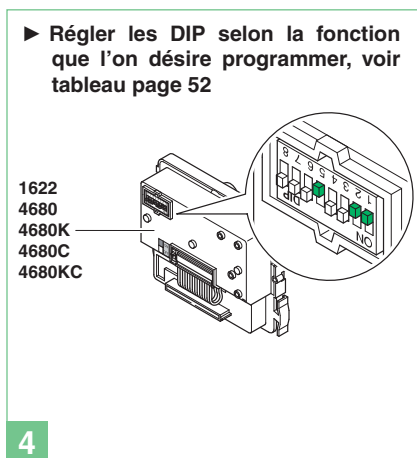

4

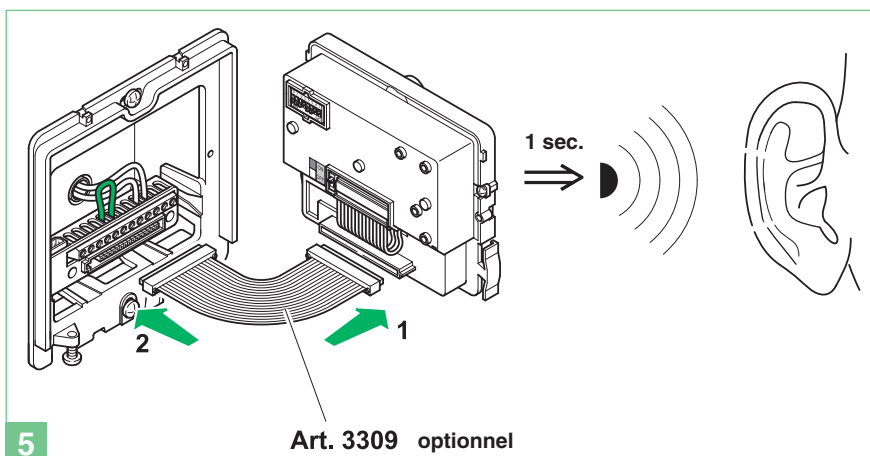

5

Art. 3309 optionnel

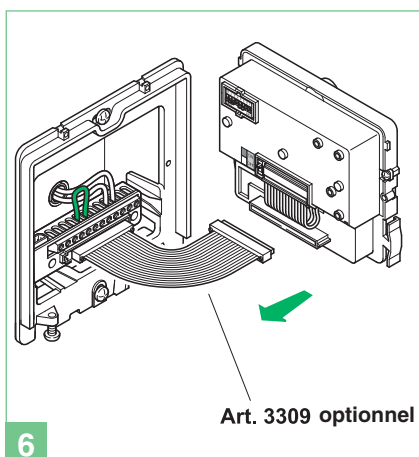

6

Art. 3309 optionnel

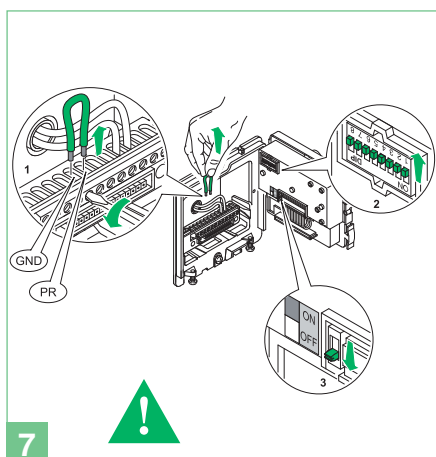

7

Code	Dip switch ON	
Résistance d'anti-buée		
213	1,3,5,7,8	OFF (default)
212	3,5,7,8	ON

Messages audiovisuels		
210	2,5,7,8	uniquement messages visuels
211	1,2,5,7,8	Suédois
214	2,3,5,7,8	OFF (default)
215	1,2,3,5,7,8	English
216	4,5,7,8	Français
217	1,4,5,7,8	Espagnol
218	2,4,5,7,8	Hollandais
219	1,2,4,5,7,8	Grec
220	3,4,5,7,8	Anglais
221	1,3,4,5,7,8	Allemand
222	2,3,4,5,7,8	Portugais

Gâche		
223	1,2,3,4,5,7,8	Commande gâche sur SE en CA (par défaut)
224	6,7,8	Commande gâche sur SE en CA intensifié
225	1,6,7,8	Commande gâche sur SE en CC

245	1,3,5,6,7,8	Temps gâche : 2 sec + tonalité désactivée (par défaut)
246	2,3,5,6,7,8	Temps gâche : 4 sec
247	1,2,3,5,6,7,8	Temps gâche : 8 sec

248	4,5,6,7,8	Tonalité confirmation gâche : actif
251	1,2,4,5,6,7,8	Relais C.NC.NO en parallèle à SE (par défaut)

252	3,4,5,6,7,8	Ouvre-porte toujours actif (par défaut)
253	1,3,4,5,6,7,8	Ouvre-porte actif uniquement pour usager appelé

Gestion commande actionneur		
REMARQUE : l'installation ne doit pas être équipée de l'Art. 1256 mode actionneur générique		
229	1,3,6,7,8	Activation relais C.NF.NO sur commande actionneur : 2 sec
230	2,3,6,7,8	Activation relais C.NF.NO sur commande actionneur : 4 sec
231	1,2,3,6,7,8	Activation relais C.NF.NO sur commande actionneur : 8 sec
228	3,6,7,8	Commande actionneur sur ligne série S : désactivée (par défaut)
227	1,2,6,7,8	Commande actionneur sur ligne série S : activée

Fonctions installation		
232	4,6,7,8	Temps d'attente réponse : 60 sec (par défaut)
233	1,4,6,7,8	Temps d'attente réponse : 120 sec
234	2,4,6,7,8	Temps d'attente réponse : 30 sec
235	1,2,4,6,7,8	Temps de conversation : 90 sec (par défaut)
236	3,4,6,7,8	Temps de conversation : 180 sec

237	1,3,4,6,7,8	Auto-allumage : actif (par défaut)
238	2,3,4,6,7,8	Auto-allumage : désactivé

239	1,2,3,4,6,7,8	Tonalité confirmation sur appel usager : actif (par défaut)
240	5,6,7,8	Tonalité confirmation sur appel usager : non actif

243	1,2,5,6,7,8	Temps d'attente reset : 10 sec (par défaut)
244	3,5,6,7,8	Temps d'attente reset : 1 sec

208	5,7,8	Reset après ouverture gâche en phonie : actif (default)
209	1,5,7,8	Reset après ouverture gâche en phonie : non actif

249	1,4,5,6,7,8	Envoi appel : unique (default)
250	2,4,5,6,7,8	Envoi appel : triple

254	2,3,4,5,6,7,8	Rétablissement réglage d'usine
-----	---------------	---------------------------------------

Waarschuwingen

- Voer de installatiewerkzaamheden zorgvuldig uit volgens de door de fabrikant gegeven instructies en met inachtneming van de geldende normen. Alle componenten mogen alleen gebruikt worden voor de doeleinden waarvoor ze zijn ontworpen. **Comelit Group S.p.A.** is niet verantwoordelijk voor oneigenlijk gebruik van de apparatuur, voor wijzigingen die om welke reden dan ook door derden zijn aangebracht, en voor het gebruik van accessoires en materialen die niet door de fabrikant zijn aangeleverd.
- Alle producten voldoen aan de eisen van de richtlijn 2006/95/EG (die de richtlijn 73/23/EEG en latere wijzigingen vervangt). Dit wordt bevestigd door het **CE**-label op de producten
- Monteer de aders van de stamleiding niet in de nabijheid van voedingskabels (230/400V).
- Voorkom het binnendringen van vreemde voorwerpen of vloeistoffen in de toestellen.
- De installatie-, montage- en servicewerkzaamheden aan de elektrische apparaten mogen uitsluitend door gespecialiseerde elektriciens worden verricht.
- Onderbreek de voeding, voordat u onderhoudswerkzaamheden uitvoert.
- Sluit het moduleframe op de aardleiding aan (zie afb.).
- Houd de telefoonhaak niet ingedrukt als de hoorn is opgenomen.
- Installeer de camera niet tegenover felle lichtbronnen of op plaatsen waar de opgenomen persoon met de rug naar het licht staat. Om het hierboven beschreven probleem op te lossen, is het raadzaam om de installatiehoogte van de videocamera, die normaal 160 - 165 cm is, te wijzigen naar een hoogte van 180 cm en om de lens naar beneden te richten, zodat de opnamekwaliteit wordt verbeterd.
- Camera's met CCD-kleurensensor hebben in schaars verlichte omstandigheden een lagere gevoeligheid dan zwart-witcamera's. Het wordt daarom aanbevolen om in schaars verlichte omgevingen een extra lichtbron te plaatsen.

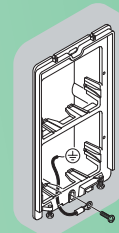

Algemeen	54
Entreepaneel	54
Art. 4879KC	54
Art. 1207	54
Installatie entreepaneel	54
Montage naambordjes	55
Interne aansluitingen	56
Montage interne aansluiting Magis	56
Verwijderen van de monitor	56
Art. 6402E	57
Beschrijving van de monitor	57
Art. 2608	58
Installatie deurtelefoon Art. 2608	58
Algemene aanwijzingen voor de installatie en de werking	59
Tabel afstanden	59
Werking	59
Beschrijving van de instellingen en werking van de knoppen	60
Instellingen monitor Art. 6402E en Style-intercom	60
TAB. A Adressen van de stamleiding	60
Beschrijving van de functies	60
Extra hoofd- of secundaire monitors	61
Gebruik van de kit in systemen met een hoofdingang	61
Programmering knoppen Art. 4680KC	62
Standaardconfiguratie	62
Algemene waarschuwingen voor de programmering van de drukknoppen	62
Programmering drukknoppen voor algemene of geadresseerde relaissturing	63
Programmeringen voor intercomoproep	63
Programmeren/wissen van een intercomadres (enkel voor selectieve intercom)	63
TAB. B Adressen voor selectieve intercom	63
Programmeringen drukknoppen voor intercomoproep	64
Programmering drukknoppen voor andere functies	64
TAB. C Adressen van de stamleiding	65
Reset van de programmering	65
Programmering range/beltonen	66
Programmering ingang IN1 voor signalering led/alarm/deuropener/relais	67
Directe programmering van de intercomoproep	68
Wijzigen van de beltonen van de monitor	68
Speciale programmeringsmogelijkheden Art. 4680KC	69
Aansluitschema's	
MSK/018IC Basisschema voor kits voor tweegezinswoningen Art. 8172IMC met aansluiting in cascade. Inwerkingstelling/spanningscontrole van een systeem in de ruststand	121
MSK/013IBC Basisschema voor kits voor tweegezinswoningen Art. 8172IMC met afgetakte aansluiting	122
MSK/014IBC Schema voor kits voor tweegezinswoningen Art. 8172IMC uitgebreid met een tweede entreepaneel Art. 4879KC. Afgetakte aansluiting	123
MSK/014IAC Schema voor kits voor tweegezinswoningen Art. 8172IMC uitgebreid met een tweede entreepaneel Art. 4879KC. Anschluss in Kaskadenschaltung	124
MSK/018I/AC Schema voor kit voor tweegezinswoning met extra voedingstransformator Art. 1595	125
MSK/019IC Gebruik module voor externe camera Art. 1259C	126
PXK/EC Aansluiting relais module Art. 1256	127
MSK/EN/109IC Schema voor aansluiting op hoofdingang van 2 tot 9 Magis Kits met Art. 4834/9	128
MSK/EN/110IC Schema voor aansluiting op hoofdingang van 30 Magis Kits (maximum) Aansluiting Magis in cascade met Art. 1424	130
SB2/AAR Aansluiting van de videoversterker Art. 4833C	132
MSK/HCA Toevoeging van een hoofdmonitor in parallelschakeling. Aansluiting in cascade	132
MSK/IC Toevoeging van een hoofdmonitor. Afgetakte aansluiting	133

MSK/A20S Aansluiting in cascade van een derde hoofdmonitor met individuele voeding	133
MSK/A23S Afgetakte aansluiting van 2 hoofdmonitors en 2 secundaire monitors met dezelfde gebruikerscode	134
MSK/A21S Aansluiting in cascade van 2 hoofdmonitors en 1 secundaire monitor met dezelfde gebruikerscode.....	134
MSK/AAE Aansluiting van extra deurtelefoons afgetakt van de monitor.....	135
MSK/AAD Aansluiting in cascade van extra deurtelefoons vanaf de monitor	135
MSK/FC Aansluiting in cascade van extra deurtelefoons vanaf de monitor.....	136
SB/X3 Gebruik voor verschillende doeleinden van drukknop P1 (Art. 2608).....	136
SB2V/AAK Aansluiting van een extra bel (Art. 1229 of Art. 1122/A).....	137
Variante met aansluiting van een etagebel	137
Gebruik ingang IN1 als contact voor signalering LED/ALARM/DEUROPENER/RELAIS. Activering bij sluiting naar CFP2	138
Gebruik ingang IN1 als contact voor signalering LED/ALARM/DEUROPENER/RELAIS. Activering bij aanwezigheid van spanning ten opzichte van IN ..	138
SB2/AAM2 Gebruik voor verschillende doeleinden van drukknop P1.....	139
PXK/RTNP Gebruik relais entreepaneel op deuropener of relaissturing (zie Speciale programmeringsmogelijkheden, pag. 69: Beheer relaissturing) .	139
PXK/SNP Variante met veiligheidsslot en extra voeding.....	140
Gebruik van het RC-net voor storingsfilter op de contacten van het relais	140
PXK/DO Gebruiksvariant van de signalering 'deur open'.....	141

Algemeen

De Kits Video-intercoms Tweegezinswoning Art. 8172IMC kunnen gebruikt worden in civiele gebouwen of dienstgebouwen waar een efficiënte toegangscontrole vereist is gecombineerd met eenvoudige installatiewerkzaamheden.

Er zijn slechts 2 aders nodig tussen het entreepaneel en de interne monitor(s) om het systeem te activeren (oproep, intercom, video, beeldoproep), plus 2 draden voor de voeding van het entreepaneel en het elektrische slot en 2 draden voor de voeding van het interne video-intercomtoestel.

Daarnaast is een uitgebreid assortiment accessoires beschikbaar, die een eenvoudige oplossing bieden voor alle eisen die aan de installatie worden gesteld: naast interessante standaardaccessoires, kan de installatie worden uitgebreid met video-intercoms en/of extra deurtelefoons en/of entreepanelen. Op die manier kunnen maximaal 2 entreepanelen met 8 interne aansluitingen gerealiseerd worden waaronder deurtelefoons en video-intercoms voor de tweegezinsconfiguratie.

Met geschikte instellingen kunnen eengezinsintercomoproepen gedaan worden (dat wil zeggen tussen gebruikers met dezelfde gebruikerscode) bij gebruik van zowel video-intercoms als deurtelefoons.

Op een Simplebus-hoofdentreepaneel en/of een centrale Art. 1998A kunnen meerdere kits worden aangesloten.

Entreepaneel

Art. 4879KC

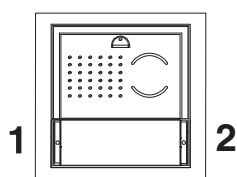

Art. 4879KC

Technische gegevens

Aansluiting op de monitor met 2 draden voor audio, video, deuropener en oproepen plus 2 draden voor voeding vanaf Art. 1207.

Instelbare camera met hoge gevoeligheid en 1/3" CCD-sensor.
 Naambordjes met verlichting met leds met de keuze blauw, wit en uit.
 Volumeregeling luidspreker.
 Afmeting inbouwdoos: 118x118x45 mm.
 De drukknoppen van Art. 4879KC zijn in de fabriek ingesteld voor de oproep naar de adressen 1 (linker drukknop) en 2 (rechter drukknop).
 Afmeting entreepaneel: 112x89,5x40 mm.

Beschrijving van het aansluitblok

- LL** aansluiting monitor (video, oproep, audioverbinding, deuropener).
- V+ V-** voeding entreepaneel.
- RTE** ingang lokale deuropener met tijdsinstelling.
- DO** ingang signalering 'deur open'.
- PR** programmeerklem.
- GND** negatieve klem voor gebruik tijdens het programmeren.
- NO NC COM** contacten van het relais van 10A.
- SE** aansluiting elektrisch slot.

Art. 1207

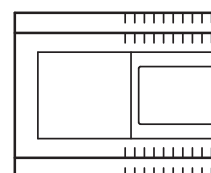

Technische gegevens

De transformator heeft 2 uitgangen: één voor de voeding van het entreepaneel en het elektrische slot en één voor de voeding van de monitor.
 Afmetingen: 105x85x85 mm (6 DIN-modulen)
 Beveiliging tegen kortsluiting en overbelasting.

Beschrijving van het aansluitblok

- L** $\frac{\perp}{\text{N}}$ ingang netspanning 110-240 VAC
- +22V 0V** uitgang DC voeding van de monitor
- +33V 0V** DC-uitgang voor entreepaneel en elektrisch slot

Installatie entreepaneel

► Laat de installatiebeveiliging op zijn plaats.

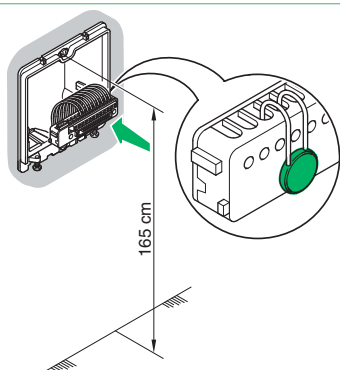

1

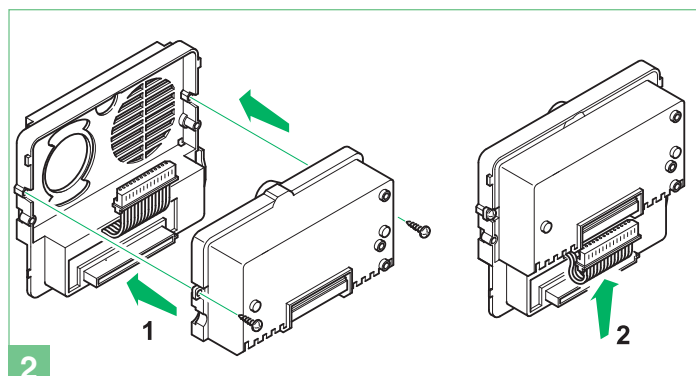

2

► Selectie ledverlichting naambordjes

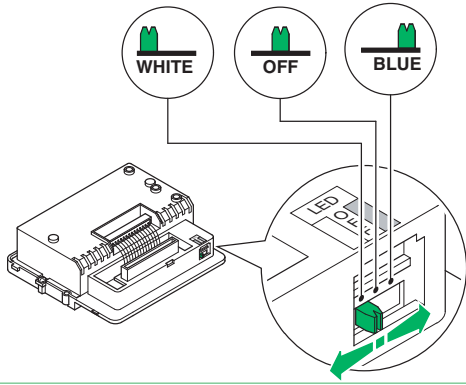

3

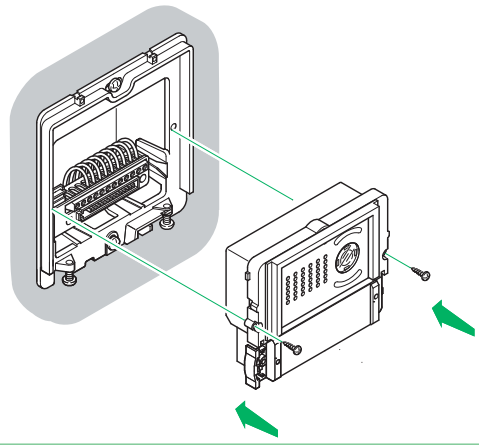

4

Alternatieve positie van de microfoon

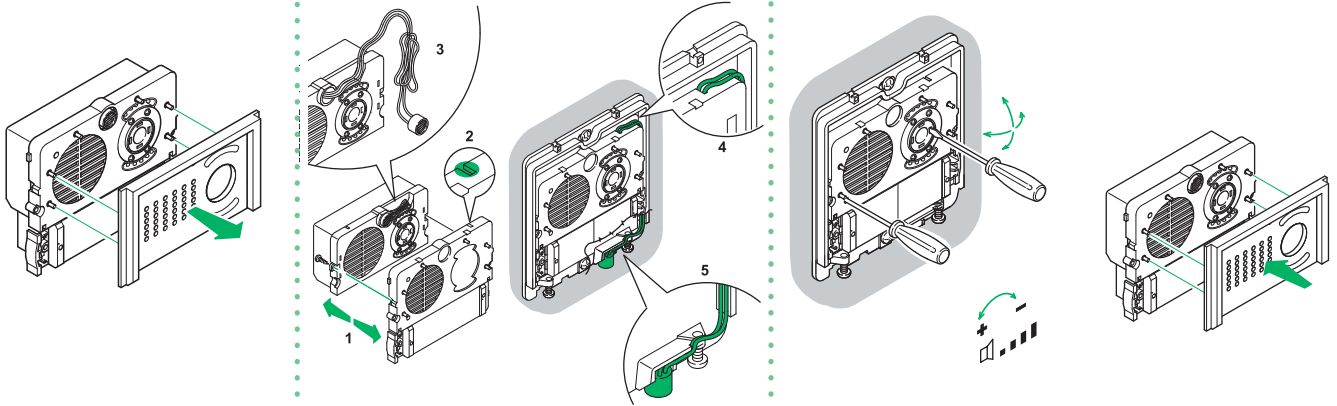

4A

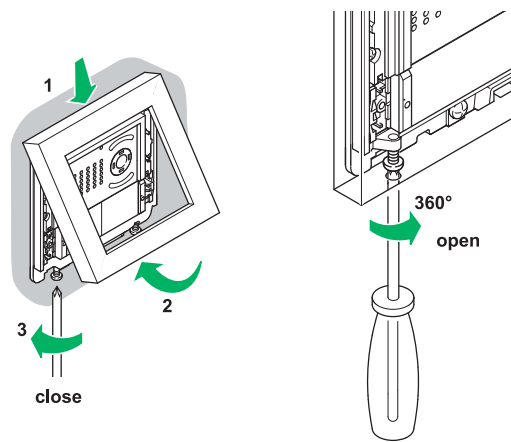

5

Montage naambordjes

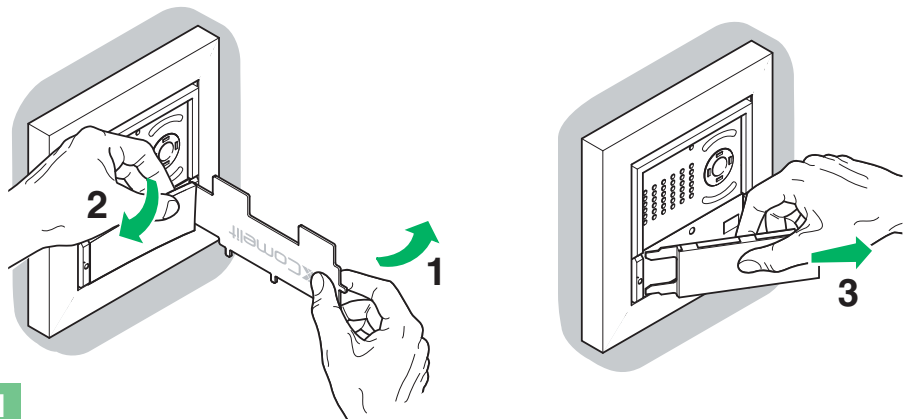

1

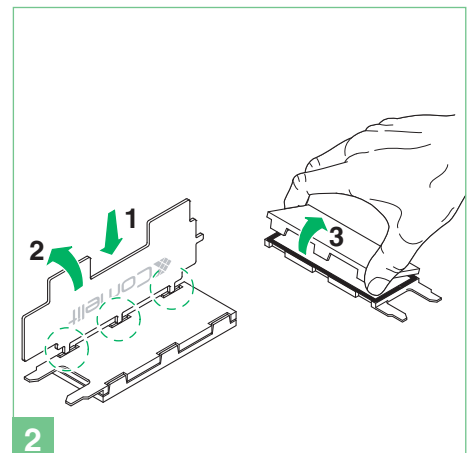

2

► Centreer het naambordje om te voorkomen dat er water kan binnendringen
OK



3

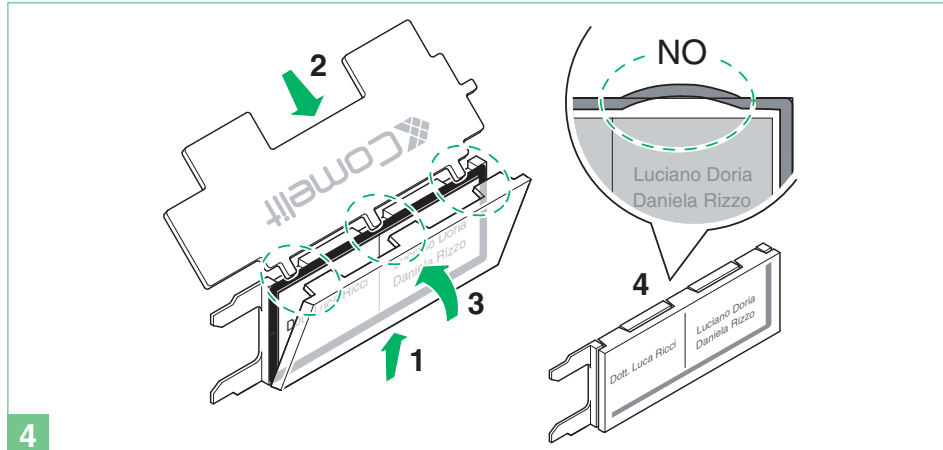

4

Interne aansluitingen

Montage interne aansluiting Magis

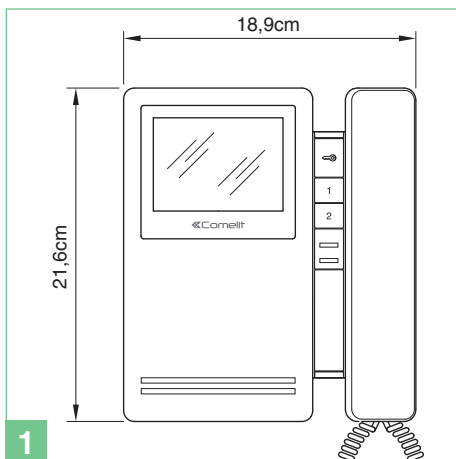

1

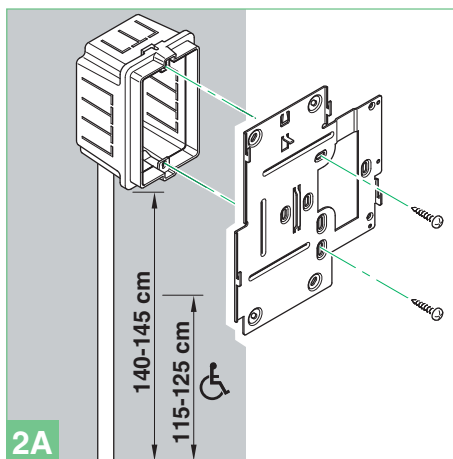

2A

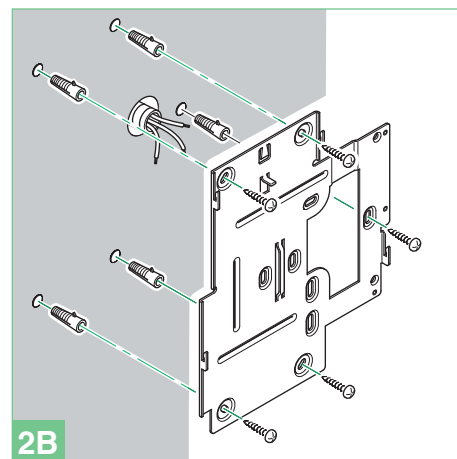

2B

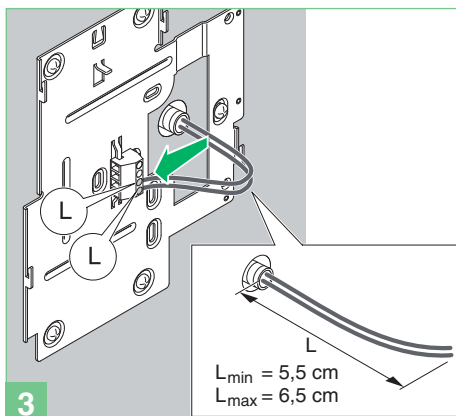

3

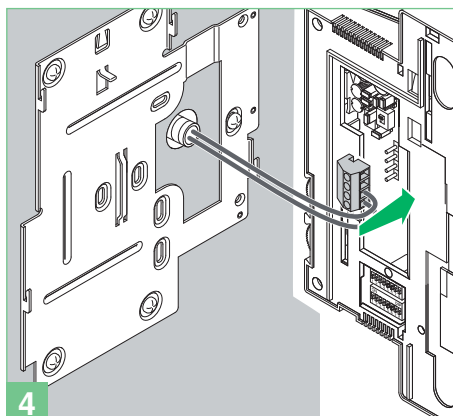

4

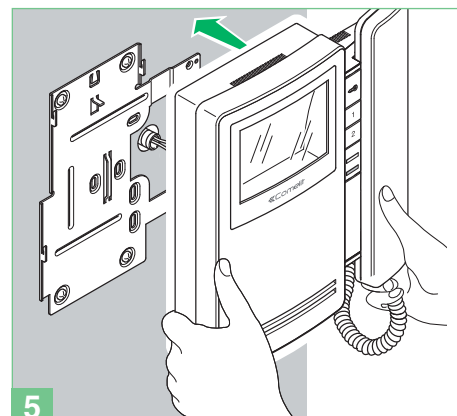

5

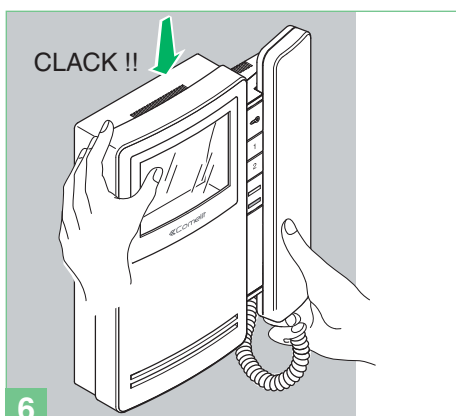

6

Verwijderen van de monitor

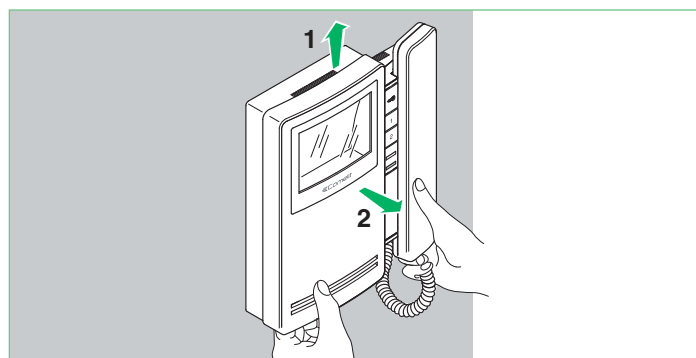

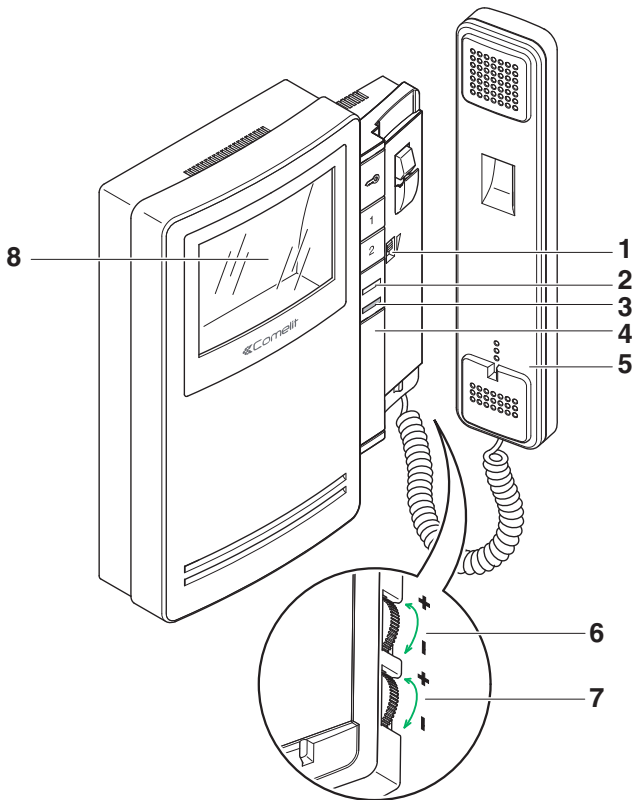

Beschrijving van de monitor:

- 1 Instelling belvolume / schakelaar privacyfunctie (de privacyfunctie schakelt oproepen vanaf het entreepaneel en vanaf deurtelefoons of video-intercommonitors uit; l'attivazione wanneer de privacyfunctie actief is, is een rode indicator naast de schakelaar zichtbaar).
- 2 Signaalled (standaard beschikbaar) voor bezetmelding/artsfunctie aan/deur open.
- 3 Indicatielampje rood - privacy actief.
- 4 Ruimte voor extra knoppen met accessoire Art. 6333, Art. 6434.
- 5 Hoorn van de monitor (de hoorn opnemen om een gesprek te voeren).
- 6 Knop voor instelling van de kleursterkte.
▶ Naar links draaien om de waarde te verhogen.
- 7 Knop voor instelling van de helderheid.
▶ Naar links draaien om de waarde te verhogen.
- 8 Kleurenscherm 3,5".

Beschrijving van de drukknoppen:

- ☞ Deuropener.
- 1 Toets 1 algemene relaissturing (programmeerbaar).
- 2 Toets 2 beeldoproep (programmeerbaar).

Beschrijving van de monitor

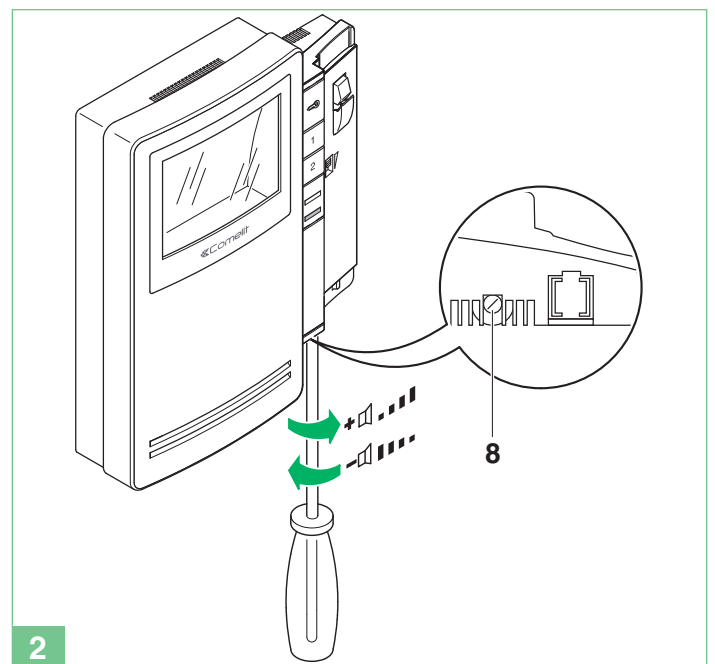
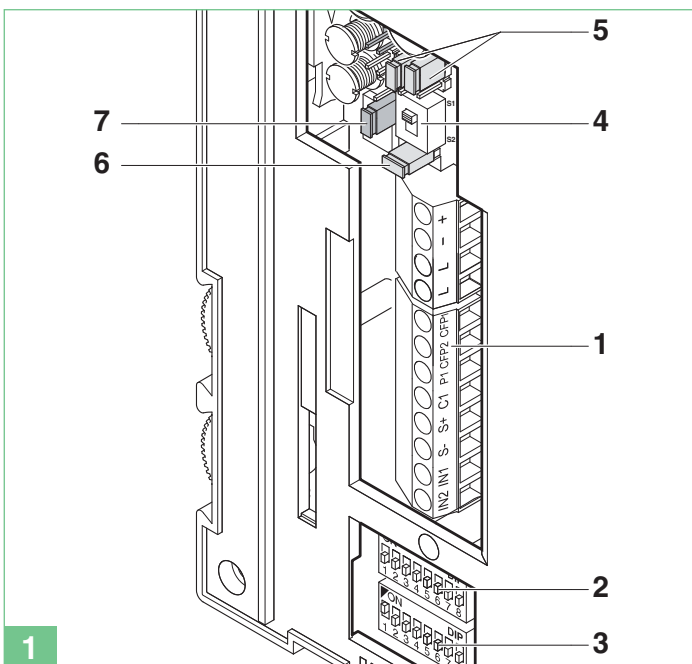

- 1 Aansluitblok voor aansluiting van het systeem:
+ - Klemmen voor voeding.
L L Klemmen voor aansluiting busleiding.
CFP1 CFP2 Ingang voor etagebel.
P1 C1 Klemmen drukknop 1 voor verschillende functies.
Voor een C.NO.-contact (max. 24V-100mA) zet u de jumpers CV3 en CV4 op stand B.
S+ S- Klemmen voor aansluiting van extra bel.
IN1 IN2 Ingang led (programmeerbaar).
- 2 S1 Microschakelaars voor programmering van de gebruikerscode.
- 3 S2 Microschakelaars voor de programmering van drukknoppen en functies (te herkennen aan rode driehoek):
DIP 1-2-3-4 voor de programmering van de functies van de drukknoppen.
DIP 5-6 toegang tot de programmeringen.

- DIP 7 voor beheer voedingsspanning (zie schema's en varianten vanaf pag. 121) default = **OFF**.
- DIP 8:
ON secundaire grondplaat.
OFF hoofdgrondplaat (default).
- 4 SW3 Keuzeschakelaar voor de modus Simplebus 1 (S1 - default) of Simplebus 2 (S2).
- 5 CV3 CV4 Jumper voor het vrijmaken van drukknop 1 (C.NO.-contact max. 24V-100mA).
A drukknop 1 algemene relaissturing (standaard) of programmeerbaar.
B drukknop 1 voor diverse functies.
- 6 CV5 Jumper voor het afsluiten van het videosignaal.
- 7 CV6 keuzeschakelaar voor gebruik ingang IN 1 (zie pag. 138).
- 8 Volumeregeling luidspreker (alleen voor geluidsinstelling intercom).

Art. 2608

De deurtelefoon kan niet worden gebruikt voor intercomfuncties. De deurtelefoon moet altijd gemonteerd worden met behulp van Art. 1214/2C, zoals afgebeeld in het aansluitschema MSK/FC op pag. 136.

- 1 Indicatielampje voor privacyfunctie.
- 2 Keuzeschakelaar beltoon/privacyfunctie met 3 standen:
Bovenste stand: luide beltoon.
Middelste stand: normale beltoon.
Onderste stand: inschakeling privacyfunctie.
(Met de privacyfunctie wordt bedoeld dat de beltoon van een oproep vanaf het entreepaneel en vanuit de centrale uitgeschakeld wordt. Wanneer de privacyfunctie actief is, brandt er een rood indicatielampje rechtsboven).
- 3 Trimmer voor volumeregeling van microfoon.
- 4 Microschakelaars voor instelling gebruikerscode.
- 5 Aansluitklemmen voor de installatie:
L L Aansluiting op de buslijn.
CFP CFP Ingang voor etagebel.
P1 C1 Klemmen drukknop P1 voor verschillende functies (C. 24V-100mA max) (CV1 en CV2 verwijderen, zie variant SB/X3 op pag. 136).
S+ S- Klemmen voor aansluiting van extra bel.
- 6 CV1 CV2 Jumper, te verwijderen om drukknop P1 C. NO potentiaalvrij te maken.
- 7A/7B JP1 Jumper voor het selecteren van de functie Bellen naar portierscentrale (stand C) / Algemene relaissturing (stand A) van de drukknop P1.

Beschrijving van de drukknoppen:

- ☞ Knop deuropener.
- P1 Drukknop P1 bellen naar portierscentrale/algemene relaissturing/ drukknop voor verschillende doeleinden aanwezig in aansluitblok (P1 C1).

Reinigen met een met water bevochtigde doek. Vermijd het gebruik van alcohol en andere agressieve producten.

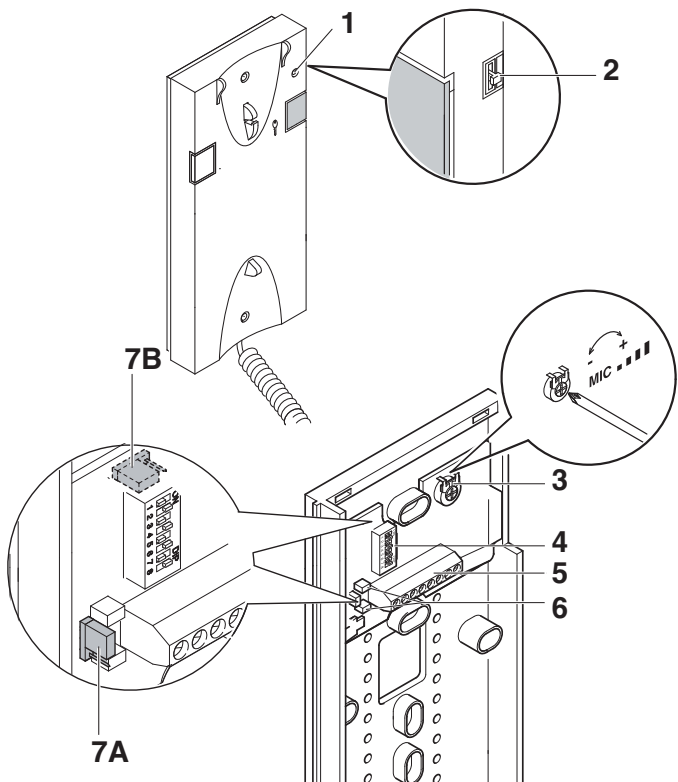

Installatie deurtelefoon Art. 2608

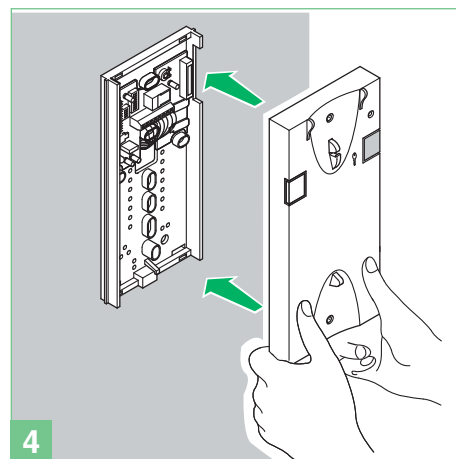
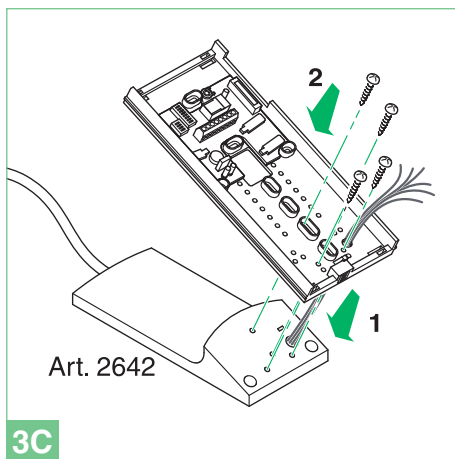
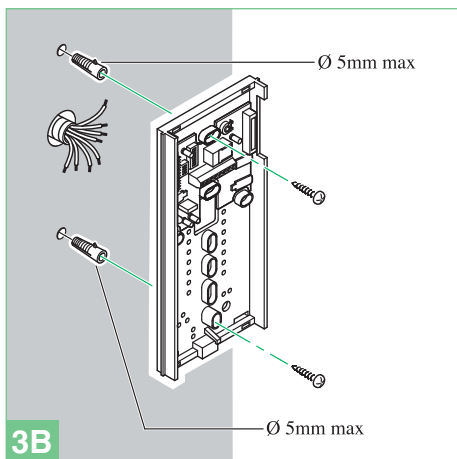
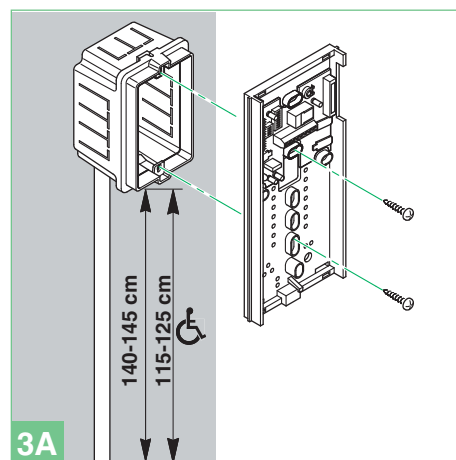
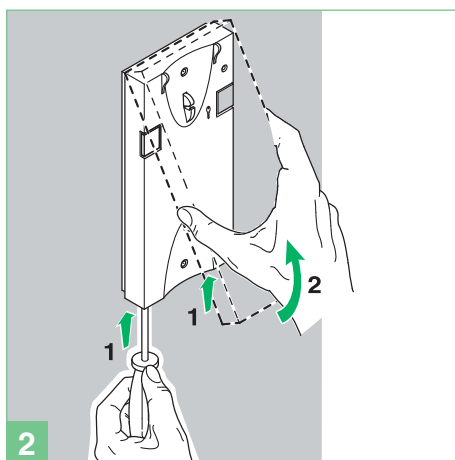
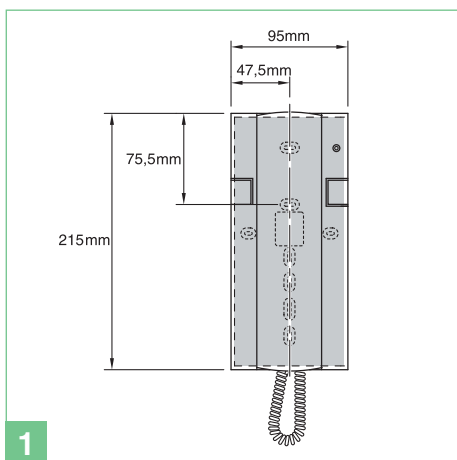

Algemene aanwijzingen voor de installatie en de werking



















De maximale totale afstand tussen het entreepaneel en de verst verwijderde monitor is 400 m (met versterker Art. 4833C).

Het aantal interne aansluitingen met dezelfde gebruikerscode en het aantal extra bellen die op bovenstaande interne aansluitingen zijn aangesloten mogen samen niet meer dan 4 zijn.

Sluit één extra bel aan per interne aansluiting.

De MAXIMALE afstand van de verbinding tussen de interne aansluiting en de extra bel bedraagt 20m; gebruik afgeschermd kabel voor deze verbinding en leid de kabels niet in de nabijheid van hoge inductieve belastingen of voedingskabels (230V / 400V).

Tabel afstanden

		A/G MAX	B/E MAX	C MAX	D MAX	F MAX	Art. 1216
Comelit Art. 4577 1 mm ² (Ø 1,2 mm AWG 17)		 50 m (165 feet)	50 m (165 feet)	200 m (655 feet)	100 m (330 feet)	150 m (495 feet)	
Comelit Art. 4576-4578	0,5 mm ² (Ø 0,8 mm AWG 20) bus	 25 m (85 feet)	25 m (85 feet)	200 m (655 feet)	100 m (330 feet)	150 m (495 feet)	
	1,5 mm ² (Ø 1,4 mm AWG 15) power	 75 m (245 feet)	100 m (330 feet)				
UTP5 cat. 5 0,2 mm ² (Ø 0,5 mm AWG 24)		 5 m (15 feet)		190 m (625feet)	60 m (195 feet)	150 m (495 feet)	
0,28 mm ² (Ø 0,6 mm AWG 23)		 5 m (15 feet)		190 m (625 feet)	60 m (195 feet)	150 m (495 feet)	
0,5 mm ² (Ø 0,8 mm AWG 20)		 25 m (85 feet)	25 m (85 feet)	190 m (625 feet)	60 m (195 feet)	150 m (495 feet)	
1 mm ² (Ø 1,2 mm AWG 17)		 50 m (165 feet)	50 m (165 feet)	190 m (625 feet)	60 m (195 feet)	150 m (495 feet)	
1 mm ² (Ø 1,2 mm AWG 17)		 50 m (165 feet)	50 m (165 feet)	120 m (395 feet)	40 m (130 feet)	100 m (330 feet)	
1,5 mm ² (Ø 1,4 mm AWG 15)		 75 m (245 feet)	100 m (330 feet)	190 m (625 feet)	60 m (195 feet)	150 m (495 feet)	
2,5 mm ² (Ø 1,8 mm AWG 13)		 100 m (330 feet)	150 m (495 feet)	190 m (625 feet)	60 m (195 feet)	150 m (495 feet)	

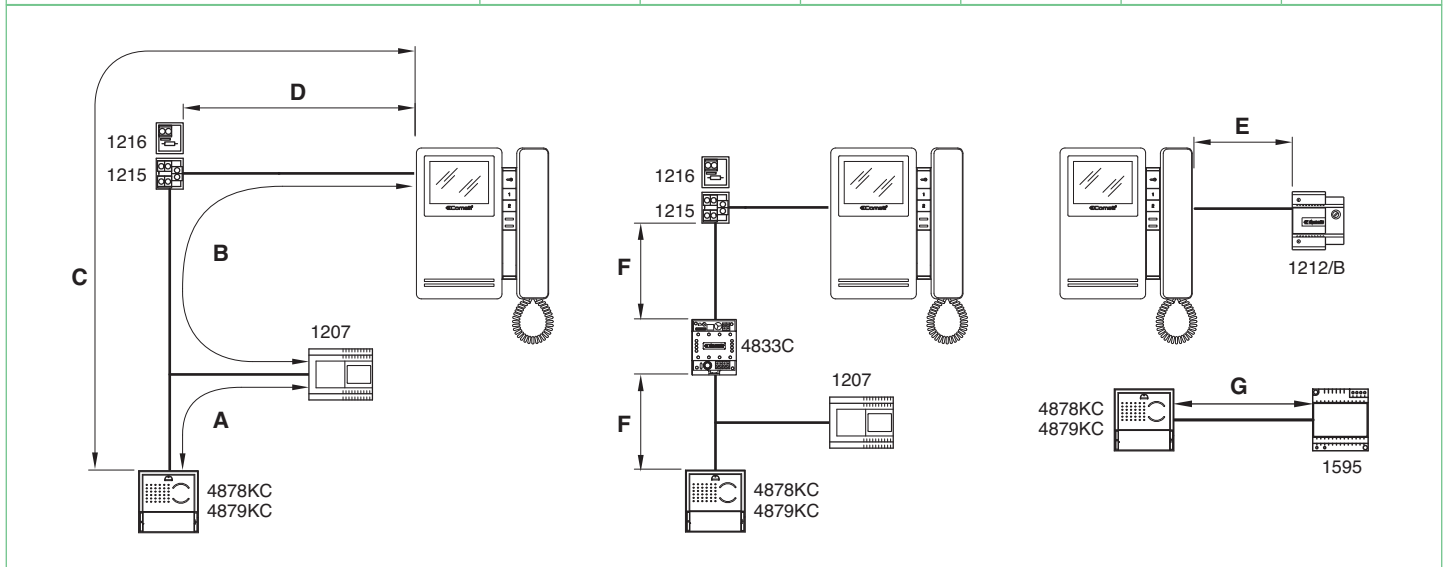

Werking



In geval van voortdurende kortsluiting op de buslijn klinkt bij het entreepaneel een intermitterende waarschuwingston.

Als de bezoeker op de oproep-toets drukt, gaan de witte leds voor de verlichting van de persoon branden, gaat de interne beltoon over (als de privacyfunctie niet is ingeschakeld) en verschijnt het beeld op de hoofdmonitor(en) gedurende circa 60".

De maximale tijdsduur van het gesprek tussen entreepaneel en interne aansluiting bedraagt 90".

Wanneer bij systemen met 2 of meerdere ingangen bij het entreepaneel na de oproep een bezettoon klinkt in plaats van de herhaling van de beltoon, betekent dit dat er al een andere spraakverbinding naar een ander entreepaneel bezig is.

Zie pagina 60 voor het programmeren van andere gebruikersadressen dan die welke zijn ingesteld in de fabriek (1 en 2).

Zie pagina 63 voor de intercomfuncties van het Magis Kit-systeem.

Beschrijving van de instellingen en werking van de knoppen

Instellingen monitor Art. 6402E en Style-intercom

Stand van de microschakelaars van de monitor Art. 6402E

► Zet bij de deurtelefoons Art. 2608, Art. 2610 en Art. 2628 de dipswitches **S1-6, S1-7, S1-8** op **OFF**.

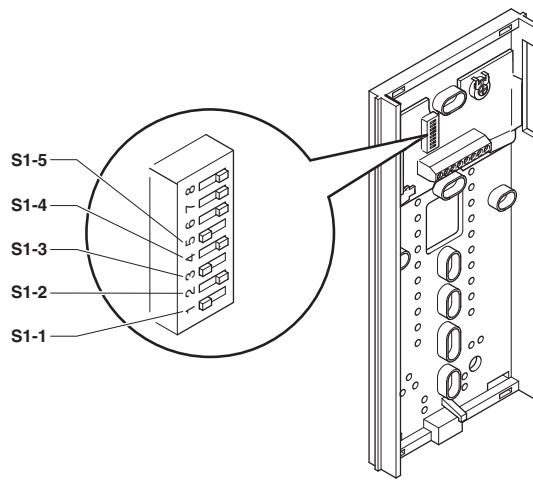
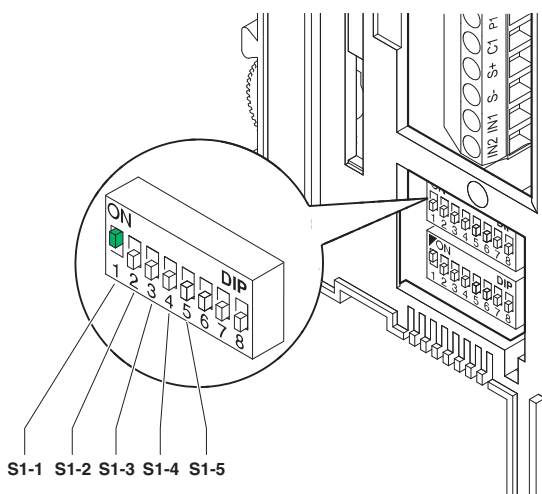

De waarden van **S1-1, S1-2, S1-3, S1-4** en **S1-5** bepalen het **oproepadres** van de monitor en van de intercoms zoals weergegeven is in de volgende tabel.

TAB. A Adressen van de stamleiding

Code	S1	Code	S1	Code	S1	Code	S1
1		9		17		25	
2		10		18		26	
3		11		19		27	
4		12		20		28	
5		13		21		29	
6		14		22		30	
7		15		23			
8		16		24			

Beschrijving van de functies

De intercomoproep tussen tweegezinswoningen (tussen deurtelefoons en/of videointercommonitoren) is alleen mogelijk als de twee gebruikers ingesteld zijn op aangrenzende oproepcodes (gemarkeerd met dezelfde letter AA..CC..OO in de programmeertabel van de microschakelaars op pagina 60).

◀ **Deuropener:** Door op de knop Deuropener te drukken, wordt het slot dat is aangesloten op het entreepaneel geactiveerd.

Relais: Door op de in de modus Relaissturing ingestelde knop te drukken kan het relais Art 1256 bekrachtigd worden, bijvoorbeeld voor het openen van hekken of garagedeuren of om de beeldwisselaar, Art. 1259C, te activeren.

Vrije knop: De aanduiding Vrije knop geeft aan dat de knop als C.NO.-contact in het aansluitblok kan worden gebruikt, door de juiste instellingen te maken, zie de variant SB2/AAM2 op pagina 139.

Beeldoproep/passieve beeldoproep

Deze functie kan ook worden gedeactiveerd.

De beeldoproepfunctie is alleen mogelijk als het systeem in de ruststand staat.

De functie Beeldoproep wordt alleen aanbevolen voor systemen met 1 of 2 ingangen.

Door op de in deze modus ingestelde knop 2 te drukken, kan op het scherm het beeld dat afkomstig is van het entreepaneel worden weergegeven, ook als er geen oproep heeft plaatsgevonden.

Bij installaties met 2 entreepanelen kan afwisselend het beeld van het ene of het andere entreepaneel weergegeven worden (functie "wisselen") door telkens op de knop 2 te drukken.

Bij secundaire monitoren (dipswitch 8 van S2 op ON) heeft de knop 2 tevens de functie van beeldoproep, hiermee kan een monitor worden ingeschakeld na een oproep vanaf het entreepaneel.

Inschakeling:

► druk op de knop voor beeldoproep van de monitor gedurende langer dan 4 sec.

» bevestigingsbeltoon.

Uitschakeling:

► druk op de knop voor beeldoproep van de monitor gedurende langer dan 4 sec.

» 4 bevestigingstonen

Inschakeling:

► De monitor wordt ingeschakeld door op de betreffende knop te

drukken (knop 2 - bij gehandhaafde fabrieksinstellingen) en deze meteen weer los te laten.

Inkomende oproep

Door op de in deze modus ingestelde knop te drukken, kan de portierscentrale van het systeem worden opgeroepen.

Intercomoproep eengezinswoning

Met deze functie kunnen andere apparaten (video-intercoms en/of deurtelefoons) die ingesteld zijn op hetzelfde oproepadres worden opgeroepen.

► Door de hoorn van het toestel te nemen, kan de gebelde persoon communiceren met de beller. De verbinding wordt verbroken door de hoorn weer op het toestel te plaatsen.

Een intercomoproep heeft geen voorrang boven een gesprek met/oproep naar het entreepaneel.

In dat geval zal tijdens een poging om een intercomoproep te doen, de led gedurende enkele seconden knipperen om aan te geven dat het systeem bezet is.

Oproep vanaf het entreepaneel

Een oproep vanaf het entreepaneel heeft echter altijd voorrang boven een intercomgesprek. (Het inschakelen van de communicatie met het entreepaneel onderbreekt het eerder aan de gang zijnde intercomgesprek). De gebruikers die reeds met elkaar in gesprek zijn, horen in de hoorn een toon die gelijk is aan een oproeptoon als de oproep voor hen bestemd is, of anders een drietonige waarschuwing.

► Om de oproep van het entreepaneel te beantwoorden, moet de hoorn van een vrij apparaat worden opgenomen, of moet de hoorn van een apparaat waarop een intercomgesprek gaande is worden opgehangen en weer opgenomen.

Artsfunctie

Met deze functie kan de deuropener automatisch in werking gesteld worden bij een oproep vanaf het entreepaneel naar het adres van de interne aansluiting waarop deze functie geactiveerd is.

Inschakeling / uitschakeling:

► houd de knop die voor deze functie is ingesteld gedurende 2 sec. ingedrukt.

»als de functie actief is, blijft de signaalled aan.

Extra hoofd- of secundaire monitors

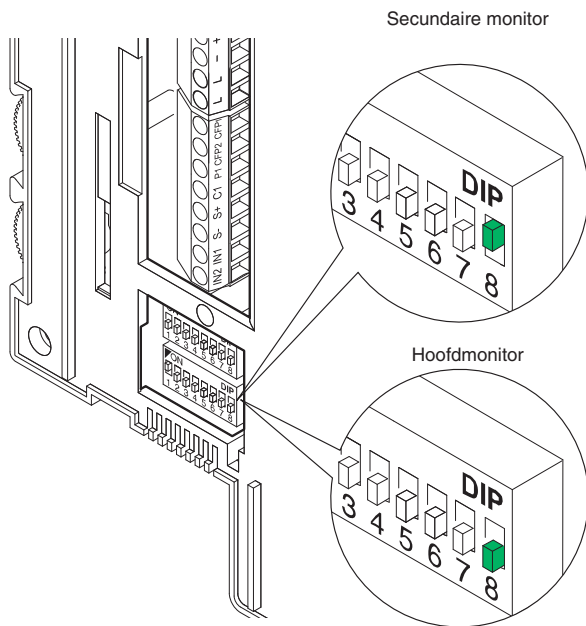

De instelling van dipswitch 8 van S2 bepaalt of de grondplaat in kwestie zal worden beheerd als hoofdgrondplaat (P) of secundaire grondplaat (S). Het entreepaneel kan maximaal 4 video-intercoms of deurtelefoons per oproeptoets beheren.

In de traditionele configuratie van de Magis Kit kunnen maximaal 2 hoofd-video-intercoms en 2 secundaire video-intercoms per oproeptoets bestaan die allemaal worden gevoed door hetzelfde **Art. 1207**.

Binnen één gezinseenheid kunnen maximaal 3 hoofd-video-intercoms worden beheerd (d.w.z. ingesteld op dezelfde gebruikerscode). In deze specifieke configuratie moet ieder van de extra hoofd-video-intercoms worden gevoed door het speciale **Art. 1212/B** (zie variant MSK/HCA, MSK/IC pag. 132, 133).

Als er een oproep plaatsvindt vanaf het entreepaneel, zal het systeem de monitor van de hoofd-video-intercom inschakelen.

Eventuele secundaire monitors van dezelfde gezinseenheid blijven uit.

Als een oproep van het entreepaneel door een secundaire video-intercom wordt beantwoordt, wordt het beeld automatisch op de monitor weergegeven.

De monitor van de hoofd-video-intercom gaat dan uit en het beeld wordt weergegeven op de monitor van de video-intercom waarvan de knop 2 beeldoproep/passieve beeldoproep is ingedrukt.

Om het beeld weer te geven zonder het geluid met het entreepaneel in te schakelen, drukt u op de knop 2 - beeldoproep/passieve beeldoproep.

Gebruik van de kit in systemen met een hoofdingang

In de schema's MSK/EN/109IC en MSK/EN/110IC op pag. 128, 131 staat een mogelijke systeemconfiguratie die de mogelijkheid biedt maximaal 30 Magis Kit-systemen te beheren met Art. 4680C - Art. 4680KC*, dat bijvoorbeeld bij de ingang van een appartementencomplex wordt geplaatst.

Als deze installatieschema's worden gevolgd kan een van de Magis Kit-systemen worden opgeroepen vanaf de hoofdingang, als deze is voorzien van Art. 4680C - Art. 4680KC*.

In deze configuratie moeten de knoppen van de module Art. 4680KC die aanwezig zijn in Art. 4879KC, zoals beschreven in de volgende procedure en de interne aansluitingen met de overeenkomstige code geprogrammeerd worden, zie de tabel op pag. 60.

Raadpleeg de catalogus (nr. 140) en de technische handleiding cod. 2G40000472, voor meer informatie over het inbouwen van de Magis Kit in Simplebus-systemen en voor de programmering van het hoofdentreepaneel (Art. 4680C - Art. 4680KC*).

* **Verwendungseinschränkungen Art. 4680KC**

Der Art. 4680KC verwaltet die von den Tasten- oder digitalen Rufmodulen eingehenden Anrufe **NUR**, wenn sie zwischen der Adresse 1 und der Adresse 10 liegen.

Programmering knoppen Art. 4680KC

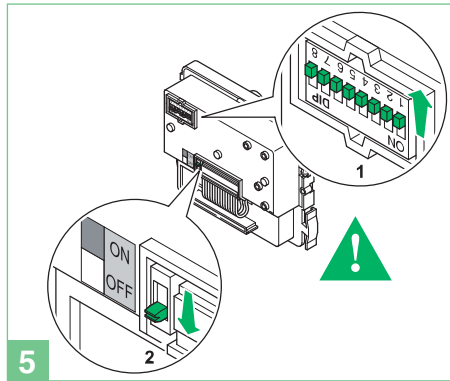
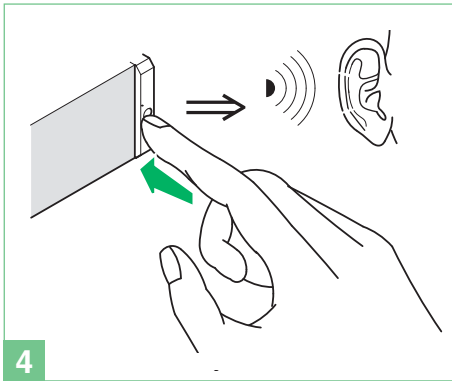
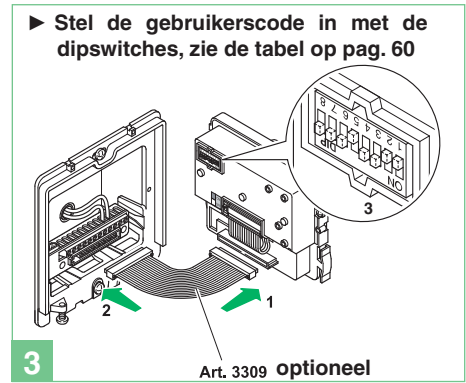
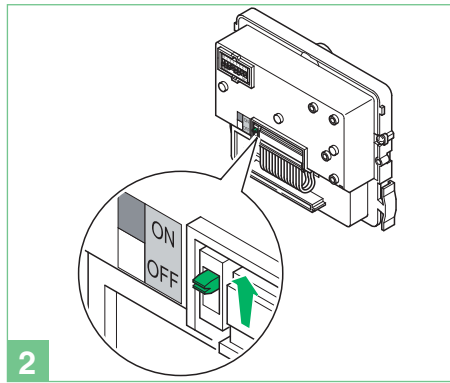
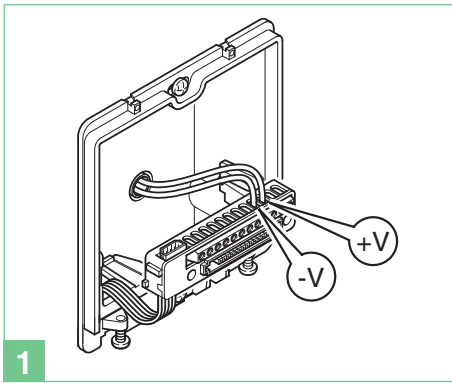

NL

Standaardconfiguratie

DIP S2				met Art. 6433, 6434							
DIP 1	DIP 2	DIP 3	DIP 4	P1	P2			P3	P4	P5	P6
0	0	0	0	CCS	AI	☞	☎	ACT	D	PAN	K
1	0	0	0	ACT	AI	☞	☎	INT	INTb	D	CCS
0	1	0	0	INT	AI			INTb	ACT	CCS	CCP
1	1	0	0	ACT	CCS			CCP	PAN	K	D
0	0	1	0	ACT	ACT	ACT		ACT	ACT	ACT	ACT
1	0	1	0	INT	ACT			CCS	CCP	INTb	PAN
0	1	1	0	AI	D			K	CCS	CCP	INTb
1	1	1	0	INTb	INT			AI	INT	PAN	D
0	0	0	1	CCS	PAN			D	AI	INT	INTb
1	0	0	1	K	CCS	☞		PAN	CCP	AI	INT
0	1	0	1	CCP	K			PAN	ACT	INT	AI
1	1	0	1	PAN	CCP			CCS	K	ACT	D
0	0	1	1	D	INTb			INT	ACT	AI	CCS
1	0	1	1	INT	INT			INT	INT	INT	INT
0	1	1	1	NULL	NULL	NULL	NULL	NULL	NULL	NULL	NULL
1	1	1	1						PROG		

Legenda

☞	Deuropener	CCS	Bellen naar portierscentrale	INTb	Intercomsysteem tweegezinswoning - alleen voor KIT
☎	Audioverbinding	K	Oproep deurtelefoon bewaker	NULL	Geen functie
ACT	Relais	D	Arts	PROG	Geprogrammeerde functies, zie pag. 62-63-64-65 Bij deze instelling van de dip behoren de drukknoppen de geprogrammeerde functies; De NIET-geprogrammeerde drukknoppen bedienen de functies vermeld op regel 0000
AI	Beeldoproep	PAN	Paniek		
CCP	Bellen naar hoofcentrale	INT	Programmeerbaar intercomsysteem, algemeen of selectief - standaard oproep eengezinswoning voor KIT en Simplebus Top		



Algemene waarschuwingen voor de programmering van de drukknoppen

Indien de standaardconfiguratie (zie tabel pag. 62) niet voldoet aan de vereisten, kunnen de drukknoppen anders worden geprogrammeerd volgens de hieronder beschreven procedure.
Aan het eind plaatst u de dipswitches 1-2-3-4 van S2 op 1111 (setting PROG in de configuratietabellen pag. 62-63-64-65). Met deze instelling van

de dipswitches bedienen de drukknoppen de geprogrammeerde functies, de NIET-geprogrammeerde drukknoppen bedienen de functies vermeld op regel 0000 (zie tabel pag. 62). Stel de instelling van de gebruikerscode opnieuw in op S1, zie tabel A op pag. 60.

Programmering drukknoppen voor algemene of geadresseerde relaissturing

DIP S2				met Art. 6433, 6434						DIP S1			
DIP 1	DIP 2	DIP 3	DIP 4	P1	P2			P3	P4	P5	P6	ADRES ON 1 2 3 4 5 6 7 8	
0	0	0	0					ACT					
1	0	0	0	ACT									
0	1	0	0						ACT				
1	1	0	0	ACT									
0	0	1	0	ACT	ACT	ACT		ACT	ACT	ACT	ACT		
1	0	1	0		ACT								
0	1	1	0										
1	1	1	0										
0	0	0	1										
1	0	0	1										
0	1	0	1						ACT				
1	1	0	1							ACT			
0	0	1	1										
1	0	1	1										
0	1	1	1										
1	1	1	1										
PROG													

Voorbeeld:

op monitor met gebruikerscode 5 is programmering P1 = algemene relaissturing, P2 = geadresseerde relaissturing met code 125.

1. Plaats dipswitches 5-6 van S2 in de combinatie 01.

» *de led (groen) knippert.*

2. Raadpleeg de tabel op pag. 63 en kies een combinatie waarin de relaisfunctie (ACT) verschijnt voor de drukknoppen die u wenst te programmeren.

Voorbeeld: voor P1 = algemene relaissturing stelt u de dipswitches 1-2-3-4 van S2 in op de combinatie 1000 of 1100 of 0010 (P1=ACT), en stelt u de dipswitch van S1 in op de combinatie 11111111, ga door naar punt 3

Voorbeeld: voor P2 = relaissturing geadresseerd op code 125 stelt u de dipswitches 1-2-3-4 van S2 in op de combinatie 0010 of 1010 (P2=ACT), en stelt u S1 in met adres 125 volgens **tabel C** op pag. 65, ga door naar punt 3.

3. Duw op de drukknop waaraan u de functie wil toewijzen en laat weer los.
» *de led (groen) gaat aan.*

» *bevestigingston in de hoorn.*

4. Om de programmering te verlaten stelt u dipswitches 5-6 van S2 in op de combinatie 00.

» *de led (groen) gaat uit.*

5. Aan het eind van de programmering stelt u de dipswitches 1-2-3-4 van S2 in op de combinatie 1111. Stel de instelling van de gebruikerscode opnieuw in op S1, zie **tabel C** op pag. 65.

Programmeringen voor intercomoproep



De algemene en selectieve intercom zijn **NIET** compatibel op dezelfde stamleiding.

Programmeren/wissen van een intercomadres (enkel voor selectieve intercom)

	! 2)						3)	
S1	DIP 1	DIP 2	DIP 3	DIP 4	DIP 5	DIP 6	S2	
Programmering: code invoeren, TAB. B op pag. 63	0	0	0	1	1	1	 ON 1 2 3 4 5 6 7 8	 2 sec
Wissen	1	1	1	1	1	1	 ON 1 2 3 4 5 6 7 8	 2 sec



Noteer de instelling van S2, S1 en herstel deze aan het einde van de programmering.

TAB. B Adressen voor selectieve intercom

Code	Dip switch ON	S1	Code	Dip switch ON	S1	Code	Dip switch ON	S1
1	1		4	4		7	7	
2	2		5	5		8	8	
3	3		6	6				

Het intercomadres moet bij alle binnentoestellen van de stamleiding worden ingesteld.

Het is mogelijk om hetzelfde intercomadres aan max. 3 binnentoestellen te koppelen.

Voor de groepsoproep moeten de gewenste intercomcodes tegelijkertijd worden geselecteerd (max. 3).

Programmeringen drukknoppen voor intercomoproep

DIP S2								met Art. 6433, 6434				DIP S1	
DIP 1	DIP 2	DIP 3	DIP 4	P1	P2			P3	P4	P5	P6	ADRES ON 1 2 3 4 5 6 7 8	
0	0	0	0										
1	0	0	0					INT	INTb				
0	1	0	0	INT				INTb					
1	1	0	0										
0	0	1	0							INTb			
1	0	1	0	INT							INTb		
0	1	1	0	INTb	INT				INT				
0	0	0	1							INT	INTb		
1	0	0	1								INT		
0	1	0	1							INT			
1	1	0	1										
0	0	1	1		INTb			INT					
1	0	1	1	INT	INT			INT	INT	INT	INT		
0	1	1	1										
1	1	1	1										

Voorbeeld 1 - Selectieve intercom

op monitor met gebruikerscode 1 en intercomadres 1 is programmering P3 = selectieve intercom op adres 2, P4 = selectieve intercom op adres 3.

Voorbeeld 2 - Intercom KIT (intercom tussen 2 aangrenzende adressen binnen de range van 1 tot 30, waarvan het eerste oneven is):

op monitor met gebruikerscode 1 is programmering P3 = interne algemene oproep, P4 = intercomsysteem tweegezinswoning op adres 2.

1. Stel de dipswitches 5-6 van S2 in op de combinatie 01.

» *de led (groen) knippert.*

2. Raadpleeg de tabel op pag. 64 en kies een combinatie waarin de intercomfunctie (INT of INTb) verschijnt voor de drukknoppen die u wenst te programmeren.

Voorbeeld 1: voor P3 = selectieve intercom stelt u de dipswitches 1-2-3-4 van S2 in op de combinatie 1000 of 0011 of 1011 (P3=INT), en stelt u S1 in met adres 2 volgens **tabel B** op pag. 63, ga naar punt 3.

Voorbeeld 1: voor P4 = selectieve intercom stelt u de dipswitches 1-2-3-4 van

S2 in op de combinatie 1110 of 1011 (P4=INT), en stelt u S1 in met adres 3 volgens **tabel B** op pag. 63, ga naar punt 3.

Voorbeeld 2: voor P3 = interne algemene oproep en P4 = intercomsysteem tweegezinswoning stelt u de dipswitches 1-2-3-4 van S2 in op de combinatie 1000 (P3=INT, P4=INTb), en stelt u S1 in met gebruikerscode 1 volgens **tabel A** op pag. 60, ga naar punt 3.

3. Duw op de drukknop waaraan u de functie wil toewijzen en laat weer los

» *de led (groen) gaat aan.*

» *bevestigingstoon in de hoorn.*

4. Om de programmering te verlaten stelt u dipswitches 5-6 van S2 in op combinatie 00.

» *de led (groen) gaat uit.*

5. **Aan het eind van de programmering stelt u de dipswitches 1-2-3-4 van S2 in op de combinatie 1111. Stel de instelling van de gebruikerscode opnieuw in op S1, zie tabel A op pag. 60.**

Programmering drukknoppen voor andere functies

DIP S2								met Art. 6433, 6434			
DIP 1	DIP 2	DIP 3	DIP 4	P1	P2			P3	P4	P5	P6
0	0	0	0	CCS	AI				D	PAN	K
1	0	0	0		AI					D	CCS
0	1	0	0		AI					CCS	CCP
1	1	0	0		CCS			CCP	PAN	K	D
0	0	1	0								
1	0	1	0								
0	1	1	0	AI	D			CCS	CCP		PAN
1	1	1	0					K	CCS	CCP	D
0	0	0	1	CCS	PAN			D	AI		
1	0	0	1	K	CCS			PAN	CCP	AI	
0	1	0	1	CCP	K			PAN			AI
1	1	0	1	PAN	CCP			CCS	K		D
0	0	1	1	D						AI	CCS
1	0	1	1								
0	1	1	1	NULL	NULL	NULL	NULL	NULL	NULL	NULL	NULL
1	1	1	1								

Legenda

	Deuropener	CCS	Bellen naar portierscentrale	NULL	Geen functie
	Audioverbinding	K	Oproep deurtelefoon bewaker	PROG	Geprogrammeerde functies
AI	Beeldoproep	D	Arts		
CCP	Bellen naar hoofcentrale	PAN	Paniek		

Voorbeeld:

op de monitor met gebruikerscode 5 is programmering P5 = beeldoproep, P6 = bellen naar intercomcentrale.

1. Stel de dipswitches 5-6 van S2 in op de combinatie 01.

» *de led (groen) knippert.*

2. Raadpleeg de tabel op pag. 64 en kies een combinatie waarin de gewenste/nodige functies verschijnen voor de drukknoppen die u wenst te programmeren.

Voorbeeld: voor P5 = beeldoproep en P6 = bellen naar intercomcentrale, stelt u de dipswitches 1-2-3-4 van S2 in op de combinatie 0011 (P5=AI, P6=CCS).

3. Duw de drukknop waaraan u de functie wil toewijzen en laat weer los.

» *de led (groen) gaat aan.*

» *bevestigingstoon in de hoorn.*

4. Om de programmering te verlaten stelt u dipswitches 5-6 van S2 in op de combinatie 00.

» *de led (groen) gaat uit.*

5. **Aan het eind van de programmering stelt u de dipswitches 1-2-3-4 van S2 in op de combinatie 1111.**

TAB. C Adressen van de stamleiding

Code	Dip switch ON	Code	Dip switch ON	Code	Dip switch ON	Code	Dip switch ON	Code	Dip switch ON	Code	Dip switch ON	Code	Dip switch ON	Code	Dip switch ON
1	1	31	1,2,3,4,5	61	1,3,4,5,6	91	1,2,4,5,7	121	1,4,5,6,7	151	1,2,3,5,8	181	1,3,5,6,8	211	1,2,5,7,8
2	2	32	6	62	2,3,4,5,6	92	3,4,5,7	122	2,4,5,6,7	152	4,5,8	182	2,3,5,6,8	212	3,5,7,8
3	1,2	33	1,6	63	1,2,3,4,5,6	93	1,3,4,5,7	123	1,2,4,5,6,7	153	1,4,5,8	183	1,2,3,5,6,8	213	1,3,5,7,8
4	3	34	2,6	64	7	94	2,3,4,5,7	124	3,4,5,6,7	154	2,4,5,8	184	4,5,6,8	214	2,3,5,7,8
5	1,3	35	1,2,6	65	1,7	95	1,2,3,4,5,7	125	1,3,4,5,6,7	155	1,2,4,5,8	185	1,4,5,6,8	215	1,2,3,5,7,8
6	2,3	36	3,6	66	2,7	96	6,7	126	2,3,4,5,6,7	156	3,4,5,8	186	2,4,5,6,8	216	4,5,7,8
7	1,2,3	37	1,3,6	67	1,2,7	97	1,6,7	127	1,2,3,4,5,6,7	157	1,3,4,5,8	187	1,2,4,5,6,8	217	1,4,5,7,8
8	4	38	2,3,6	68	3,7	98	2,6,7	128	8	158	2,3,4,5,8	188	3,4,5,6,8	218	2,4,5,7,8
9	1,4	39	1,2,3,6	69	1,3,7	99	1,2,6,7	129	1,8	159	1,2,3,4,5,8	189	1,3,4,5,6,8	219	1,2,4,5,7,8
10	2,4	40	4,6	70	2,3,7	100	3,6,7	130	2,8	160	6,8	190	2,3,4,5,6,8	220	3,4,5,7,8
11	1,2,4	41	1,4,6	71	1,2,3,7	101	1,3,6,7	131	1,2,8	161	1,6,8	191	1,2,3,4,5,6,8	221	1,3,4,5,7,8
12	3,4	42	2,4,6	72	4,7	102	2,3,6,7	132	3,8	162	2,6,8	192	7,8	222	2,3,4,5,7,8
13	1,3,4	43	1,2,4,6	73	1,4,7	103	1,2,3,6,7	133	1,3,8	163	1,2,6,8	193	1,7,8	223	1,2,3,4,5,7,8
14	2,3,4	44	3,4,6	74	2,4,7	104	4,6,7	134	2,3,8	164	3,6,8	194	2,7,8	224	6,7,8
15	1,2,3,4	45	1,3,4,6	75	1,2,4,7	105	1,4,6,7	135	1,2,3,8	165	1,3,6,8	195	1,2,7,8	225	1,6,7,8
16	5	46	2,3,4,6	76	3,4,7	106	2,4,6,7	136	4,8	166	2,3,6,8	196	3,7,8	226	2,6,7,8
17	1,5	47	1,2,3,4,6	77	1,3,4,7	107	1,2,4,6,7	137	1,4,8	167	1,2,3,6,8	197	1,3,7,8	227	1,2,6,7,8
18	2,5	48	5,6	78	2,3,4,7	108	3,4,6,7	138	2,4,8	168	4,6,8	198	2,3,7,8	228	3,6,7,8
19	1,2,5	49	1,5,6	79	1,2,3,4,7	109	1,3,4,6,7	139	1,2,4,8	169	1,4,6,8	199	1,2,3,7,8	229	1,3,6,7,8
20	3,5	50	2,5,6	80	5,7	110	2,3,4,6,7	140	3,4,8	170	2,4,6,8	200	4,7,8	230	2,3,6,7,8
21	1,3,5	51	1,2,5,6	81	1,5,7	111	1,2,3,4,6,7	141	1,3,4,8	171	1,2,4,6,8	201	1,4,7,8	231	1,2,3,6,7,8
22	2,3,5	52	3,5,6	82	2,5,7	112	5,6,7	142	2,3,4,8	172	3,4,6,8	202	2,4,7,8	232	4,6,7,8
23	1,2,3,5	53	1,3,5,6	83	1,2,5,7	113	1,5,6,7	143	1,2,3,4,8	173	1,3,4,6,8	203	1,2,4,7,8	233	1,4,6,7,8
24	4,5	54	2,3,5,6	84	3,5,7	114	2,5,6,7	144	5,8	174	2,3,4,6,8	204	3,4,7,8	234	2,4,6,7,8
25	1,4,5	55	1,2,3,5,6	85	1,3,5,7	115	1,2,5,6,7	145	1,5,8	175	1,2,3,4,6,8	205	1,3,4,7,8	235	1,2,4,6,7,8
26	2,4,5	56	4,5,6	86	2,3,5,7	116	3,5,6,7	146	2,5,8	176	5,6,8	206	2,3,4,7,8	236	3,4,6,7,8
27	1,2,4,5	57	1,4,5,6	87	1,2,3,5,7	117	1,3,5,6,7	147	1,2,5,8	177	1,5,6,8	207	1,2,3,4,7,8	237	1,3,4,6,7,8
28	3,4,5	58	2,4,5,6	88	4,5,7	118	2,3,5,6,7	148	3,5,8	178	2,5,6,8	208	5,7,8	238	2,3,4,6,7,8
29	1,3,4,5	59	1,2,4,5,6	89	1,4,5,7	119	1,2,3,5,6,7	149	1,3,5,8	179	1,2,5,6,8	209	1,5,7,8	239	1,2,3,4,6,7,8
30	2,3,4,5	60	3,4,5,6	90	2,4,5,7	120	4,5,6,7	150	2,3,5,8	180	3,5,6,8	210	2,5,7,8	*240	5,6,7,8

*OPMERKING: de code 240 is gereserveerd voor de portierscentrale

Reset van de programmering

! 1)	! 2)						3)	4)	
S1	DIP 1	DIP 2	DIP 3	DIP 4	DIP 5	DIP 6	S2	S1/S2/LED1	
<p>DIP ON</p>	1	1	1	1	1	1	<p>5 sec</p>	<p>2 sec</p>	<p>Noteer de instelling van S2, S1 en herstel deze aan het einde van de programmering.</p>
<p>Fabrieksinstellingen:</p> <ul style="list-style-type: none"> • Functies drukknooppunten afhankelijk van de combinatie van DIP 1-2-3-4 van S2; • Intercomadres niet voorzien; • Functie range en min. en max. adressen niet voorzien; • Reset beltonen; • Ingang IN 1 => LED (default). 									

Voer de werkzaamheden van 1 tot 4 uit											
Programmering range/beltonen	1)		2)						3)		4)
	S1	S2	DIP 1	DIP 2	DIP 3	DIP 4	DIP 5	DIP 6	S1/S2/LED1		
Range minimaal adres	code instellen, TAB. C op pag. 65		0	0	0	0	1	0			
Range maximaal adres											
Activering range											
Desactivering range											
Keuze van de polyfone beltoon			0	1	0	1	1	0			
Keuze van de klassieke beltoon (default)											

Voer de werkzaamheden van 1 tot 4 uit													
		! 1)		! 2)						3)		4)	
		S1		DIP 1	DIP 2	DIP 3	DIP 4	DIP 5	DIP 6	S2		S1/S2/LED1	
Programmering ingang IN1 voor signalering led/ alarm/deuropener/relais													
Ingang IN 1 ⇒ LED (default), zie blz. 138													
Ingang IN 1 ⇒ ALARM, zie blz. 138				0	0	0	1	1	0				
Ingang IN 1 ⇒ DEUROPENER, zie blz. 138													
Ingang IN 1 ⇒ GEADRESSEERDE RELAISSTURING, zie blz. 138		code instellen, TAB. C op pag. 65											
Ingang N 1 ⇒ ALGEMENE RELAISSTURING, zie blz. 138													

! Noteer de instelling van S2, S1 en herstel deze aan het einde van de programmering

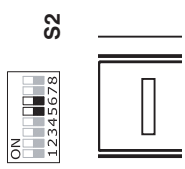
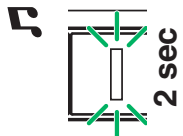

Directe programmering van de intercomoproep

Hiermee kunnen de intercomoproepen rechtstreeks vanop de binnentoestellen worden geprogrammeerd.

✓ Hiervoor zijn 2 operators nodig.

Fase 1: toegang tot programmering

Operator 1 en Operator 2 voeren dezelfde handelingen uit op 2 binnentoestellen:

1. Stel dipswitch 1-2-3-4 van S2 in op de combinatie 1111.

2. Neem de hoorn op.

3. *Houd de knoppen 1 en 2 gedurende 3 sec. ingedrukt.*

» *Er komt 1 toon uit het binnentoestel.*

» *De groene led knippert.*

» *Het binnentoestel gaat in audioverbinding.*

» *Nu kunnen de 2 operators met elkaar communiceren.*

Fase 2: programmering intercomoproep

Operator 1:

▶ Drukt op de knop die hij wil programmeren om operator 2 op te roepen (bv. 2).

» *Er komt een bevestigingston uit het binnentoestel van operator 1.*

Operator 2:

▶ Drukt op de knop die hij wil programmeren om operator 1 op te roepen (bv. 1).

» *Er komt een bevestigingston uit het binnentoestel van operator 2.*

Operator 1/Operator 2:

▶ Hang de hoorn op.

» *Er komt 1 toon uit het binnentoestel.*

» *Zo is de programmering van de 2 binnentoestellen voltooid.*

Om nog een binnentoestel te programmeren moet worden overgegaan naar FASE 3.

Fase 3: programmering van andere binnentoestellen

Operator 1/Operator 2:

1. Als hij op de nieuwe locatie is, voert hij fase 1 uit om de communicatie tot stand te brengen.

2. Herhaal fase 2.

OPMERKING: Indien er een oproep binnenkomt tijdens het programmeren, moet de oproep eerst worden beantwoord. Vervolgens kan de programmeringsfase hervat worden.

Wijzigen van de beltonen van de monitor

1. Houd knop  ingedrukt tot u een bevestigingston hoort (dit is alleen mogelijk wanneer de installatie in de ruststand verkeert; wanneer dit niet het geval is, knippert de led om de gebruiker te waarschuwen).

2. Druk op knop  en laat weer los:

1 maal (er klinkt één enkele bevestigingston) om de beltoon van een oproep vanaf het entreepaneel te wijzigen.

2 maal (er klinken 2 bevestigingstonen) om de beltoon van een oproep vanaf de intercomocentrale te wijzigen.

3 maal (er klinken 3 bevestigingstonen) om de beltoon van een intercomoproep vanaf het binnentoestel te wijzigen.

4 maal (er klinken 4 bevestigingstonen) om de beltoon van een oproep van de etagebel te wijzigen.

Wanneer u nog vaker op de knop  drukt, wordt de bovenstaande volgorde herhaald.

3. Druk op de knop 1 en laat hem weer los om de beschikbare beltonen in volgorde te beluisteren.

4. Druk op de knop 2 om de keuze van de laatst beluisterde beltoon te bevestigen en om de modus Wijzigen oproeptoon van monitor (op ieder gewenst moment) te verlaten. Wanneer u de modus Wijzigen beltoon van monitor verlaat, klinkt er een bevestigingston.

Speciale programmeringsmogelijkheden Art. 4680KC

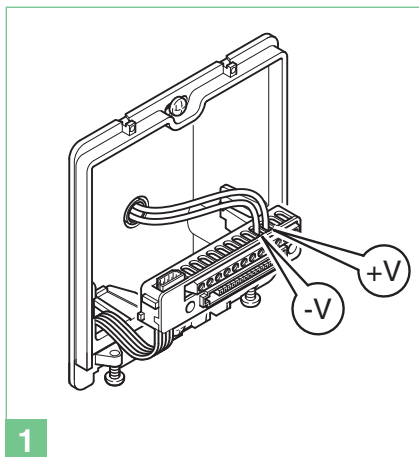

1

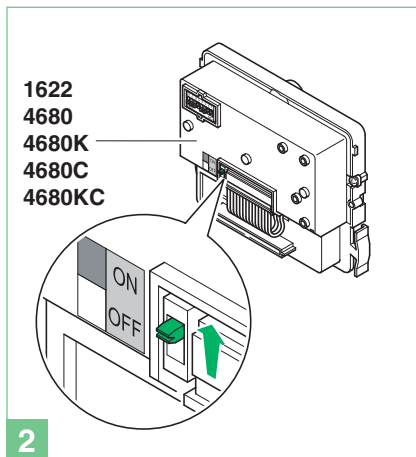

2

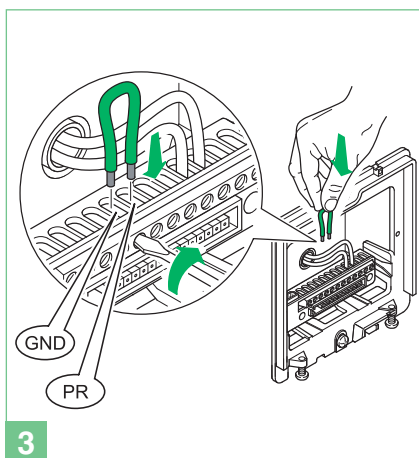

3

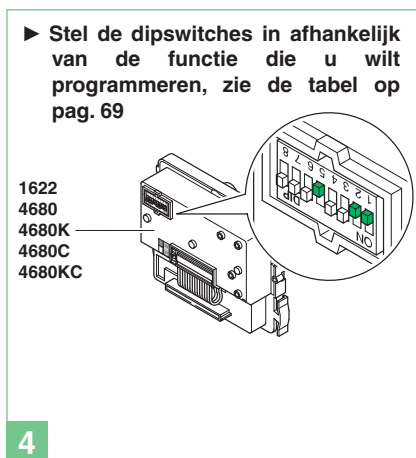

4

► Stel de dipswitches in afhankelijk van de functie die u wilt programmeren, zie de tabel op pag. 69

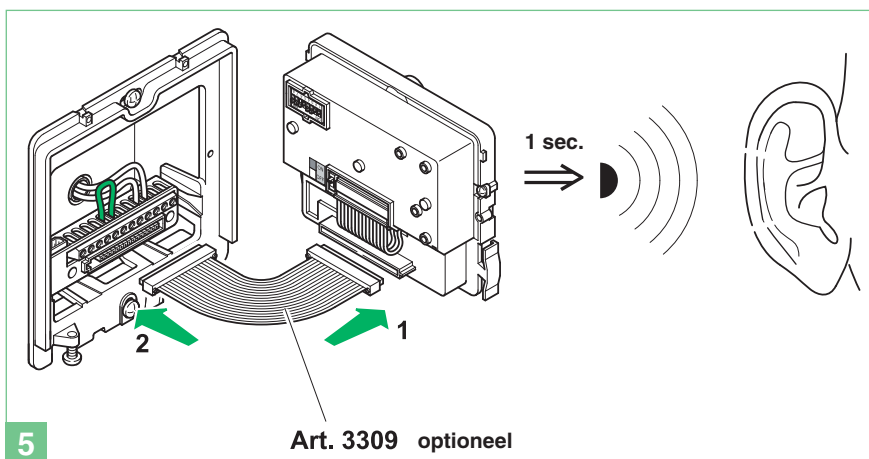

5

Art. 3309 optioneel

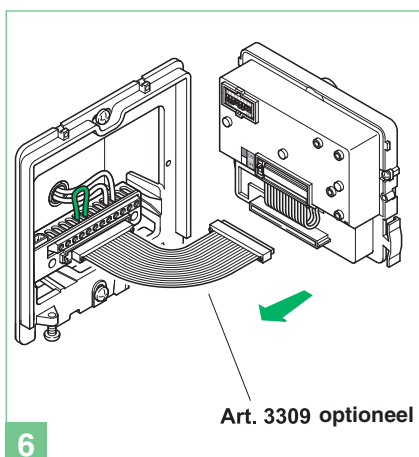

6

Art. 3309 optioneel

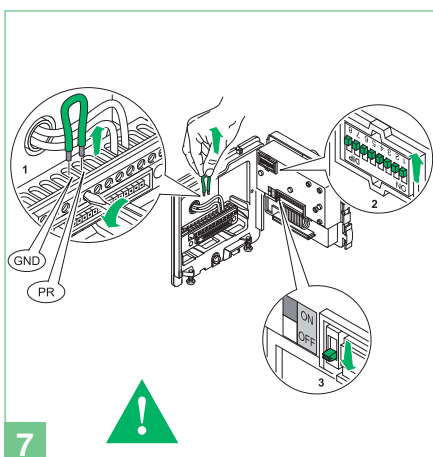

7

Code	Dip switch ON	
Weerstand tegen beslaan		
213	1,3,5,7,8	OFF (default)
212	3,5,7,8	ON

Audiovisuele berichten		
210	2,5,7,8	alleen visuele berichten
211	1,2,5,7,8	Zweeds
214	2,3,5,7,8	OFF (default)
215	1,2,3,5,7,8	Italiaans
216	4,5,7,8	Frans
217	1,4,5,7,8	Spaans
218	2,4,5,7,8	Nederlands
219	1,2,4,5,7,8	Grieks
220	3,4,5,7,8	Engels
221	1,3,4,5,7,8	Duits
222	2,3,4,5,7,8	Portugees

Slot		
223	1,2,3,4,5,7,8	Bediening slot op SE in AC (default)
224	6,7,8	Bediening slot op SE in versterkte AC
225	1,6,7,8	Bediening slot op SE in DC
245	1,3,5,6,7,8	Tijd slot: 2 sec. + toon uit (default)
246	2,3,5,6,7,8	Tijd slot: 4 sec.
247	1,2,3,5,6,7,8	Tijd slot: 8 sec.

248	4,5,6,7,8	Bevestigingstoon slot: ingeschakeld
251	1,2,4,5,6,7,8	Relais C.NC.NO in parallelschakeling met SE (default)
252	3,4,5,6,7,8	Deuropener altijd aan (default)
253	1,3,4,5,6,7,8	Deuropener alleen aan voor de opgeroepen gebruiker

Beheer relaissturing				
OPMERKING: op de installatie mag Art. 1256 niet aanwezig zijn in de modus algemene relaissturing.				
229	1,3,6,7,8	Inschakeling relais	C.NC.NO	op
		relaissturing: 2 sec.		
230	2,3,6,7,8	Inschakeling relais	C.NC.NO	op
		relaissturing: 4 sec.		
231	1,2,3,6,7,8	Inschakeling relais	C.NC.NO	op
		relaissturing: 8 sec.		
228	3,6,7,8	Relaissturing op seriële lijn S:	uitgeschakeld	(default)
227	1,2,6,7,8	Relaissturing op seriële lijn S:	ingeschakeld	

Functies installatie		
232	4,6,7,8	Wachttijd antwoord: 60 sec. (default)
233	1,4,6,7,8	Wachttijd antwoord: 120 sec.
234	2,4,6,7,8	Wachttijd antwoord: 30 sec.
235	1,2,4,6,7,8	Gesprekstijd: 90 sec. (default)
236	3,4,6,7,8	Gesprekstijd: 180 sec.
237	1,3,4,6,7,8	Automatische inschakeling (default)
238	2,3,4,6,7,8	Automatische inschakeling: uitgeschakeld

239	1,2,3,4,6,7,8	Bevestigingstoon bij oproep gebruiker: ingeschakeld (default)
240	5,6,7,8	Bevestigingstoon bij oproep gebruiker: uitgeschakeld
243	1,2,5,6,7,8	Wachttijd reset: 10 sec. (default)
244	3,5,6,7,8	Wachttijd reset: 1 sec.
208	5,7,8	Reset na deuropening met audioverbinding: ingeschakeld (default)
209	1,5,7,8	Reset na deuropening met audioverbinding: uitgeschakeld
249	1,4,5,6,7,8	Oproep: enkel (default)
250	2,4,5,6,7,8	Oproep verzenden: drievoudig

254	2,3,4,5,6,7,8	Reset default
-----	---------------	----------------------

Hinweise

- Der Einbau muss genau nach den Anweisungen des Herstellers und unter Einhaltung der einschlägigen Vorschriften erfolgen.
- Alle Geräte dürfen ausschließlich nur zu dem Zweck eingesetzt werden, für den sie entwickelt worden sind. Die **Comelit Group S.p.A.** übernimmt keine Haftung für einen unsachgemäßen Gebrauch der Geräte, für durch Dritte vorgenommene Änderungen oder die Verwendung von Nicht-Original-Zubehör und -Ersatzteilen.
- Alle unsere Produkte erfüllen die Anforderungen der Richtlinien 2006/95/EG (geändert durch die Richtlinie 73/23/EWG und deren nachfolgende Ergänzungen), wie durch ihre **CE**-Kennzeichnung bestätigt wird.
- Die Kabel der Steigleitung nicht in Nähe der Stromkabel (230/400 V) verlegen.
- Stecken Sie keine spitzen Gegenstände in das Gerät und sorgen Sie dafür, dass keine Flüssigkeiten hineingelangen können.
- Kabelverlegung sowie Einbau und Wartung der elektrischen Geräte müssen von einem Elektrofachmann ausgeführt werden.
- Vor Wartungseingriffen immer erst die Spannungsversorgung unterbrechen.
- Den Modulträger an Masse anschließen (siehe Abb.).
- Die Gabel der Sprechgarnitur bei abgehobenem Hörer nicht gedrückt halten.
- Die Kamera darf nicht vor großen Lichtquellen oder an Stellen installiert werden, an denen das Motiv zu sehr im Gegenlicht steht. Zur Lösung des obigen Problems empfiehlt sich, die Kamera auf einer Höhe von 180 cm anstatt der üblichen 160 - 165 cm zu installieren, und das Objektiv nach unten zu richten, um die Qualität der Aufnahmen zu verbessern.
- Die Kameras mit CCD-Farbsensor haben bei schlechten Lichtverhältnissen eine geringere Empfindlichkeit als Schwarz/Weiß-Kameras. In schlecht beleuchteter Umgebung wird daher empfohlen, für eine zusätzliche Lichtquelle zu sorgen.

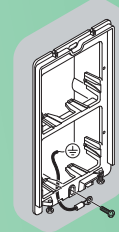

Allgemeines	71
Außenstelle	71
Art. 4879KC	71
Art. 1207	71
Installation der Außenstelle	71
Einsetzen der Namensschilder	72
Innensprechstellen	73
Einbau der Innensprechstelle Magis	73
Abnahme des Monitors	73
Art. 6402E	74
Beschreibung des Monitors	74
Art. 2608	75
Installation der Innensprechstelle Art. 2608	75
Allgemeine Installations- und Betriebshinweise	76
Tabelle der zulässigen Entfernungen der Geräte	76
Funktionsweise	76
Beschreibung Tasteneinstellungen und -funktionen	77
Einstellungen Monitor Art. 6402E und Innensprechstelle Style	77
TAB. A Adressen der Steigleitung	77
Beschreibung der Tastenfunktionen	77
Zusätzliche Haupt- oder Nebenmonitore	78
Verwendung des Sets in Anlagen mit Haupttür	78
Programmierung der Tasten Art. 4680KC	79
Default-Tastenkongfiguration	79
Allgemeine Hinweise zur Tastenprogrammierung	79
Tastenprogrammierung für allgemeine oder codierte Relaissteuerung	80
Programmierungen für Interngespräch	80
Programmierung/Löschung der Intercom-Adresse (nur für selektive Intercom-Verbindung)	80
TAB. B Adressen für selektive Intercom-Verbindung	80
Tastenprogrammierung für Interngespräch	81
Tastenprogrammierung für andere Funktionen	81
TAB. C Adressen der Steigleitung	82
Reset de Programmierung	82
Programmierung range/Ruftöne	83
Programmierung Eingang IN1 für Meldung LED/Alarm/Türöffner/Relais	84
Direkte Programmierung des Internrufs	85
Änderung der Monitor-Ruftöne	85
Besondere Programmierungen Art. 4680KC	86
Anschlusspläne	
MSK/018IC Basisschema voor kits voor tweegezinswoningen Art. 8172IMC met aansluiting in cascade. Inbetriebnahme / Spannungsprüfung der Anlage im Standby-Modus.....	121
MSK/013IBC Grundanschlussplan für Zweifamilienhaus-Sets Art. 8172IMC mit Anschluss über Abzweigung.....	122
MSK/014IBC Anschlussplan für Zweifamilienhaus-Sets Art. 8172IMC, erweitert um einen zweiten Art. 4879KC. Anschluss über Abzweigung.	123
MSK/014IAC Anschlussplan für Zweifamilienhaus-Sets Art. 8172IMC, erweitert um einen zweiten Art. 4879KC. Anschluss in Kaskadenschaltung.	124
MSK/018I/AC Schaltplan für Zweifamilienhaus mit zusätzlichem Netzteil Art. 1595.....	125
MSK/019IC Einsatz des separaten Kameramoduls Art. 1259C.....	126
PXK/EC Anschluss Relais Art. 1256.....	127
MSK/EN/109IC Plan für den Anschluss von 2 bis 9 Magis Kit an die Haupttür über Art. 4834/9.....	129
MSK/EN/110IC Plan für den Anschluss von 30 Magis Kit (max.) an die Haupttür. Anschluss von Magis in Kaskadenschaltung mit Art. 1424.....	131
SB2/AAR Anschluss Videosignalverstärker Art. 4833C.....	132
MSK/HCA Zusätzliche Installation eines Hauptmonitors in Parallelschaltung, Kaskadenverbindung.....	132
MSK/IC Zusätzliche Installation eines Hauptmonitors in Parallelschaltung, Abzweigverbindung.....	133
MSK/A20S Anschluss in Kaskadenschaltung des dritten Hauptmonitors mit lokaler Stromversorgung.....	133
MSK/A23S Anschluss über Abzweigung von 2 Hauptmonitoren und 2 Zusatzmonitor mit identischem Teilnehmercode.....	134
MSK/A21S Anschluss über Abzweigung von 2 Hauptmonitoren und 1 Zusatzmonitor mit identischem Teilnehmercode.....	134

MSK/AAE Anschluss zusätzlicher Sprechstellen mit Abzweigung vom Monitor	135
MSK/AAD Anschluss zusätzlicher Sprechstellen in Kaskadenschaltung vom Monitor	135
MSK/FC Anschluss zusätzlicher Sprechstellen in Kaskadenschaltung vom Monitor	136
SB/X3 Verwendung von Taste P1 für sonstige Funktionen (Art. 2608).....	136
SB2V/AAK Anschluss von Rufwiederholeinrichtungen (Art. 1229 bzw. Art. 1122/A)	137
Anschlussvariante Rufsignale der Außensprechstellen	137
Verwendung des Eingangs IN1 als Meldekontakt LED/ALARM/TÜRÖFFNER/RELAIS. Aktivierung bei Schließen des Kontakts zwischen IN1 und CFP2. 138	
Verwendung des Eingangs IN1 als Meldekontakt LED/ALARM/TÜRÖFFNER/RELAIS. Aktivierung bei Anliegen von Spannung im gegenüber IN2 ... 138	
Verwendung des Relais der Außensprechstelle als Türöffner oder zur Relaisansteuerung (siehe Besondere Programmierungen, Seite 86: Relaisansteuerung)	139
SB2/AAM2 Verwendung von Taste P1 für sonstige Funktionen	139
PXK/RTNP Verwendung des RC-Glieds als Türöffner-Filter an den Relaiskontakten	140
PXK/SNP Variante mit Sicherheits-Türöffner und zusätzlicher Stromversorgung	140
PXK/DO Einsatzvariante der Meldung TÜR OFFEN.....	141

Allgemeines

Die Video-Türsprechanlagen als Zweifamilienhaus-Set Art. 8172IMC können in Wohngebäuden oder im Dienstleistungssektor verwendet werden, wo eine effektive Zugangskontrolle bei gleichzeitig einfachem Installationsaufwand gefordert ist.

Zur Aktivierung des Systems (Ruf, Sprechverbindung, Video, Selbsteinschaltung) sind lediglich 2 Leiter zwischen der Außensprechstelle und dem/den Monitor/en an der/den Innensprechstelle/n sowie 2 Drähte zur Versorgung der Außensprechstelle und des elektrischen Türöffners und 2 Drähte zur Versorgung der Video-Innensprechstelle erforderlich. Zudem steht ein breites Angebot an Zubehörteilen zur Verfügung, um jeder Anlagenanforderung gerecht zu werden: Neben der Installation von interessanten Standard-Zubehörteilen kann eine bereits installierte Anlage durch Videosprech- und/oder Innensprechstellen und/oder Außenstellen erweitert werden. Somit sind in der Konfiguration als Zweifamilienhaus bis zu 2 Außenstellen mit 8 Innensprechstellen (Sprech- und/oder Videosprechgeräte) möglich.

Über entsprechende Einstellungen können sowohl mit Videosprechstellen als auch mit Innensprechstellen Interngespräche innerhalb der Einfamilienanlage (d.h. zwischen Teilnehmern mit demselben Teilnehmercode) durchgeführt werden.

Mehrere Sets können an einen Simplebus Haupteingang und/oder eine Rufzentrale Art. 1998A angeschlossen werden.

Hochempfindliche schwenkbare Videokamera mit CCD 1/3" Sensor. Namensschilder mit LED-Beleuchtung, wahlweise in blau, weiß oder ausgeschaltet.

Lautstärkeregelung Lautsprecher.

Abmessungen des Unterputzgehäuses: 118x118x45 mm.

Die Tasten von Art. 4879KC sind werkseitig für den Anruf an die Adressen 1 (linke Taste) und 2 (rechte Taste) konfiguriert.

Abmessung der Außenstelle: 112x89,5x40 mm.

Beschreibung der Klemmenleiste

LL Monitor-Anschluss (Video, Ruf, Sprechverbindung, Türöffner).

V+ V- Versorgung von Außenstelle.

RTE Eingang für zeitgesteuerten lokalen Türöffner.

DO Eingang für die Anzeige ‚Tür offen‘.

PR Programmierklemme.

GND In der Programmierphase zu verwendende Minusklemme.

NO NC COM Kontakte des 10A-Relais.

SE Anschluss elektrischer Türöffner.

Außenstelle

Art. 4879KC

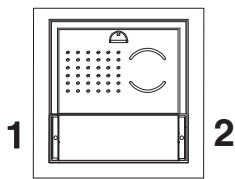

Art. 4879KC

Technische Daten

Anschluss an Monitor mit 2 Leitern für Audio, Video, Türöffner und Ruf sowie 2 Leitern zur Versorgung von Art. 1207.

Art. 1207

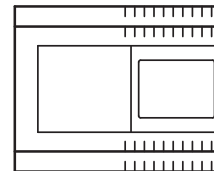

Technische Daten

Der Transformator hat 2 Ausgänge: einen für die Versorgung der Außenstelle und des elektrischen Türöffners und einen für die Versorgung des Monitors.

Abmessungen: 105x85x85 mm (6 DIN-Module).

Mit Überlast- und Kurzschlussicherung.

Beschreibung der Klemmenleiste

L $\frac{1}{2}$ **N** Eingang Netzspannung 110-240 VAC.

+22V 0V Gleichspannungsausgang zur Versorgung des Monitors.

+33V 0V Gleichspannungsausgang für Außenstelle und elektr. Türöffner.

Installation der Außenstelle

Die Sicherung der Anlage nicht entfernen

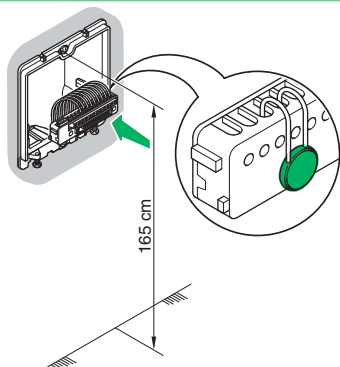

1

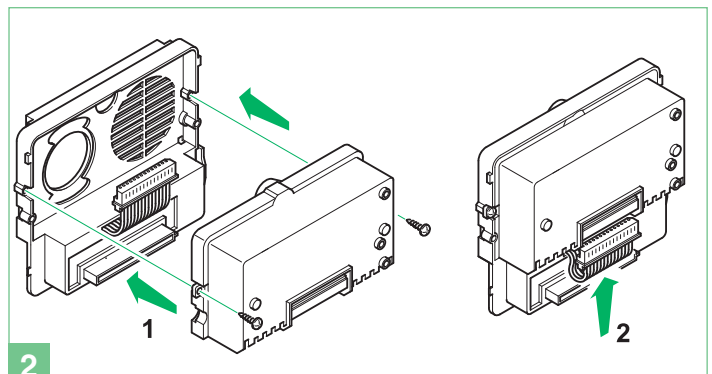

2

► Auswahl LED-Beleuchtung der Namensschilder

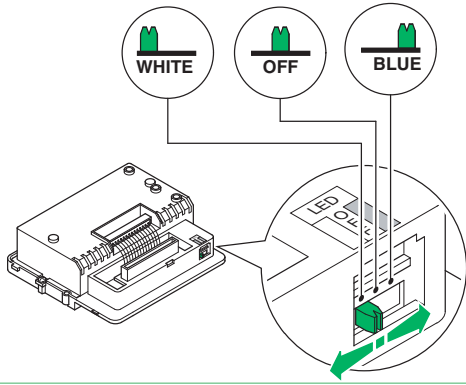

3

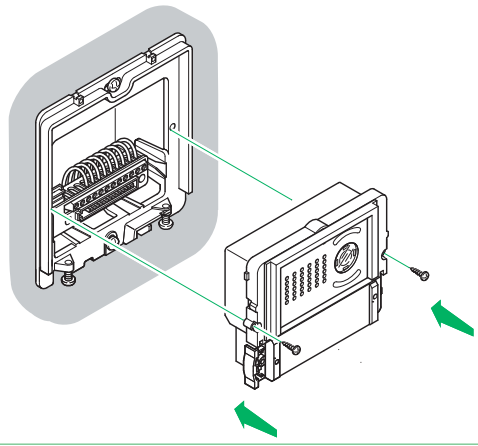

4

Alternative Position des Mikrofons

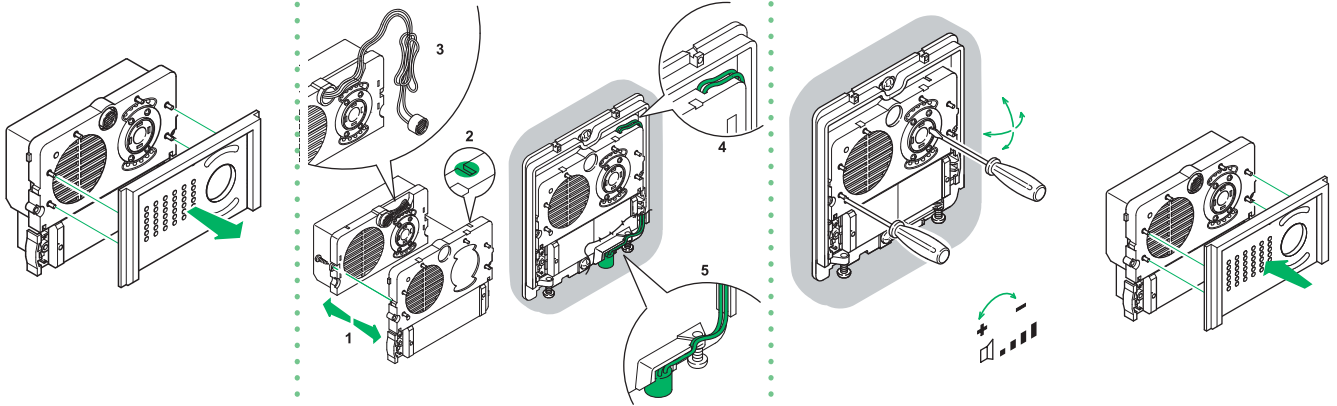

4A

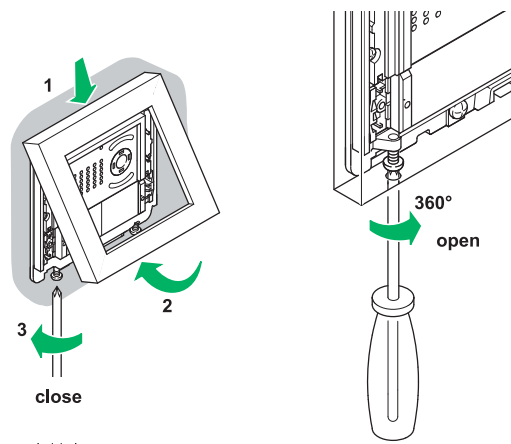

5

Einsetzen der Namensschilder

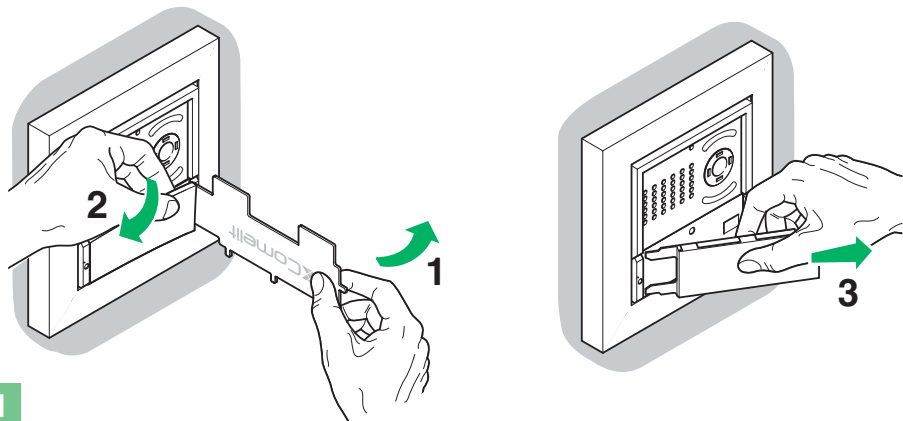

1

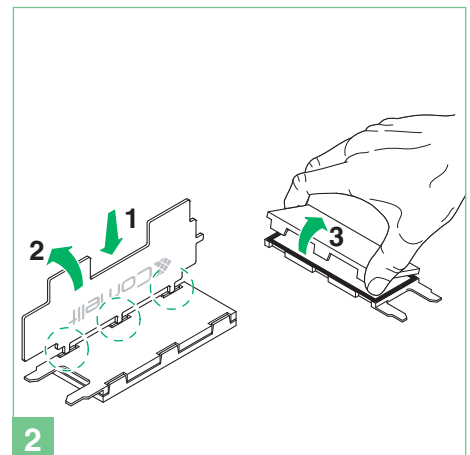

2

► Das Namensschild zentrieren, damit kein Wasser eindringen kann
OK

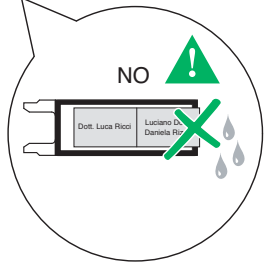

3

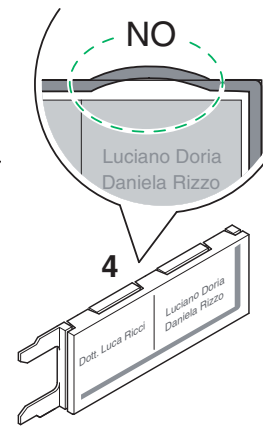
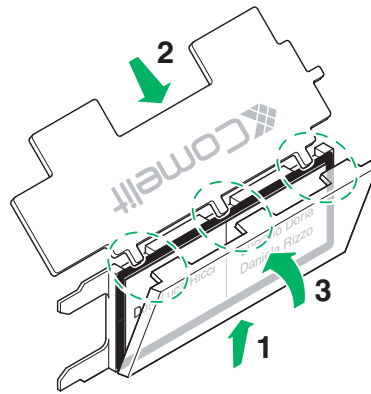

4

Innensprechstellen

Einbau der Innensprechstelle Magis

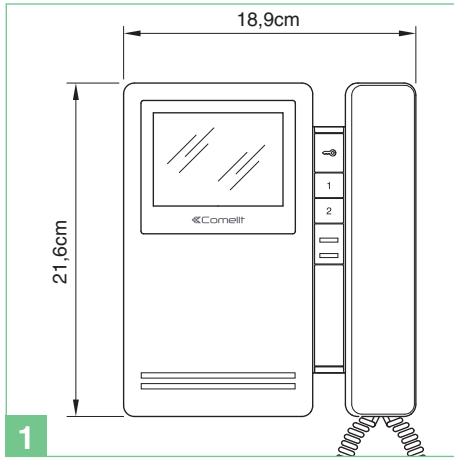

1

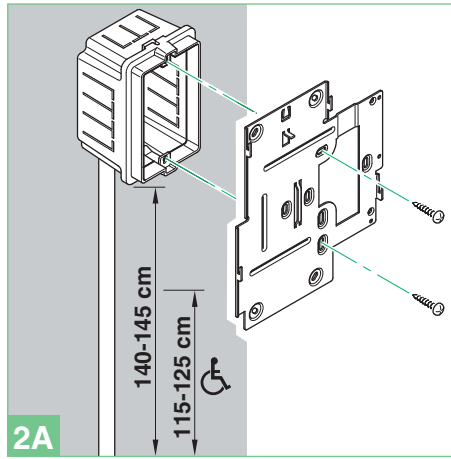

2A

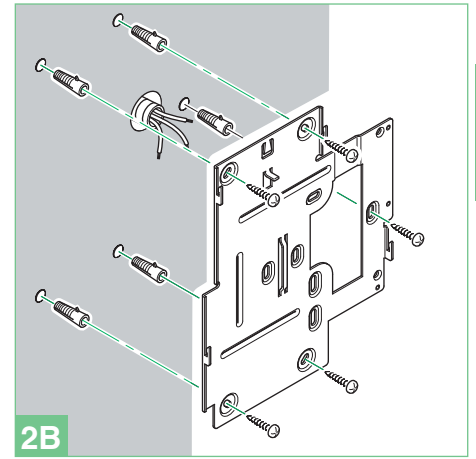

2B

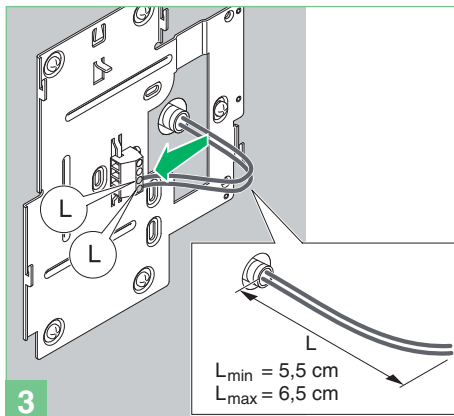

3

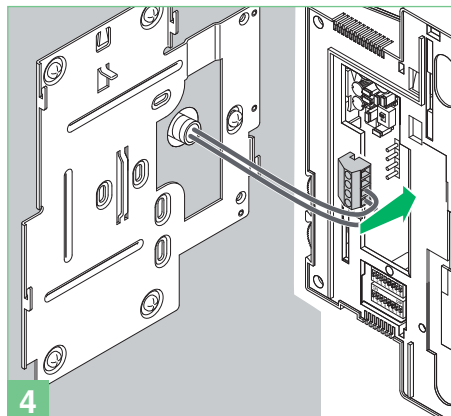

4

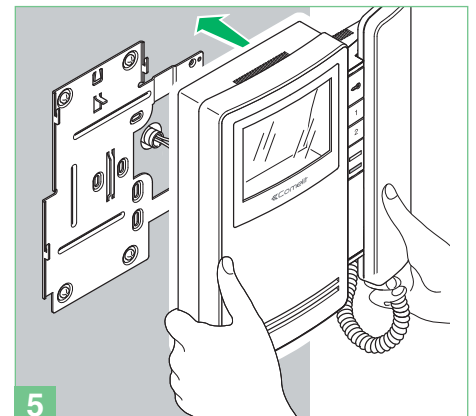

5

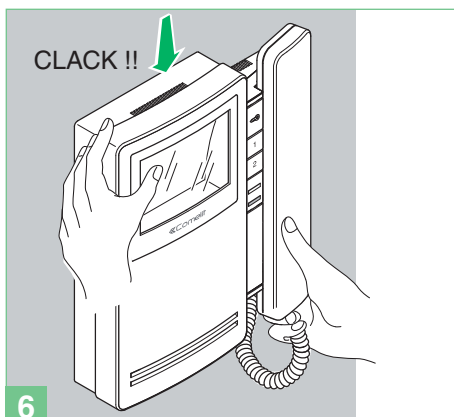

6

Abnahme des Monitors

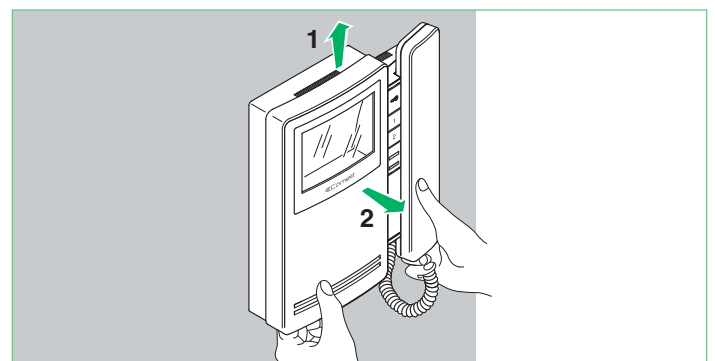

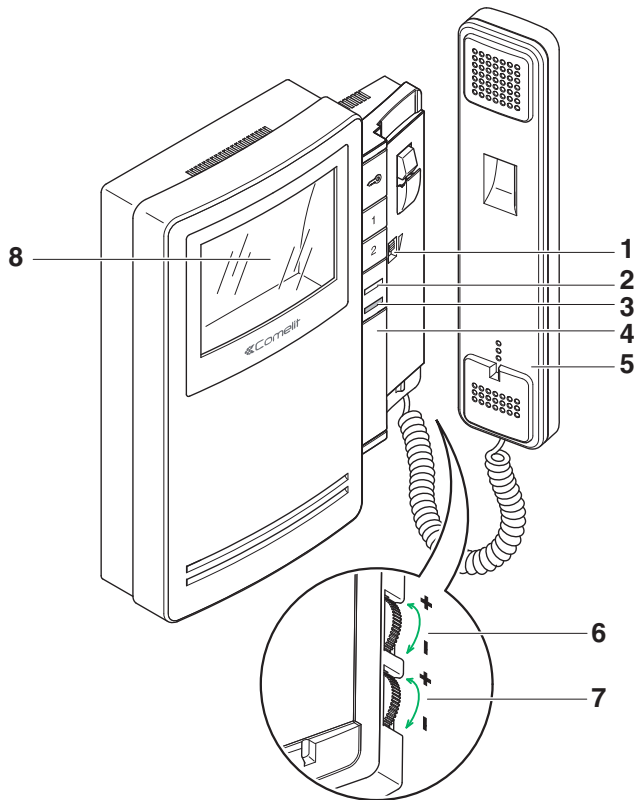

Monitorbeschreibung:

- 1 Einstellung Ruflautstärke/ Wahltaste Funktion Rufabschaltung (damit ist die Deaktivierung des Rufs von der Außenstelle und von Interngesprächen zwischen Sprech- und Videosprechstellen gemeint; die Aktivierung der Funktion Rufabschaltung wird durch das Einschalten einer roten Anzeige an der Seite des Wahlschalters angezeigt).
- 2 Anzeige-Led für Anlage besetzt/Arztruf-Funktion aktiv/tür offen.
- 3 Rote Anzeige - Privacy aktiviert.
- 4 Einbauöffnung für Zusatz Tasten mit Zubehör Art. 6333, Art. 6434.
- 5 Monitor-Hörer (den Hörer abnehmen, um mit der Kommunikation zu beginnen).
- 6 Drehregler für Farbintensitätsregelung.
▶ Gegen den Uhrzeigersinn drehen, um den Wert zu erhöhen.
- 7 Helligkeitsregler.
▶ Gegen den Uhrzeigersinn drehen, um den Wert zu erhöhen.
- 8 3,5" Farbbildschirm.

Beschreibung der Tasten:

- ☞ Türöffnertaste.
- 1 Taste 1 Standardrelais (programmierbar).
- 2 Taste 2 Selbsteinschaltung (programmierbar).

Beschreibung des Monitors

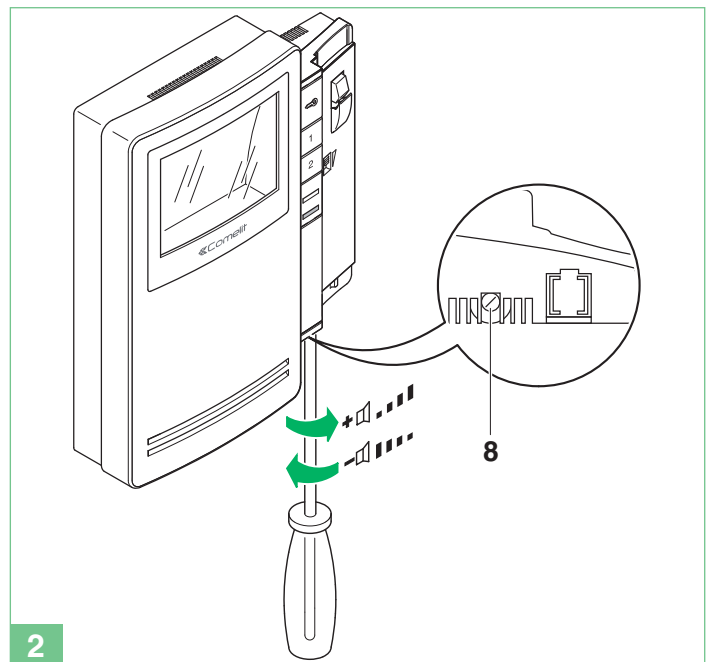
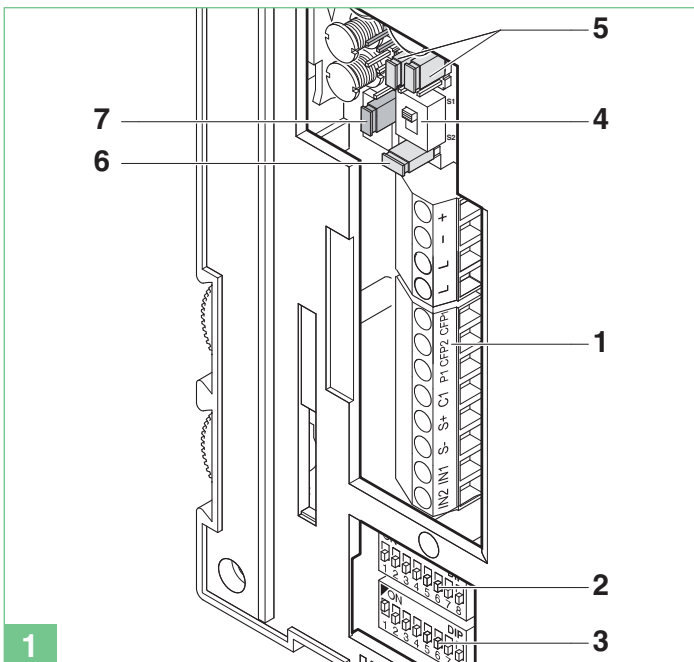

- 1 Klemmleiste für Anschluss an die Anlage:
+ - Klemmen für Stromversorgung
L L Anschlussklemmen Busleitung
CFP1 CFP2 Eingang Etagenruf
P1 C1 Klemmen Taste 1 für Zusatzfunktionen.
Zur Herstellung eines Schließerkontakts (max. 24V – 100mA) die Stecker CV3 und CV4 in Stellung B versetzen.
S+ S- Klemmen für Rufwiederholeinrichtung
IN1 IN2 Eingang LED (programmierbar).
- 2 S1 Mikroschalter für Programmierung des Benutzercodes
- 3 S2 Mikroschalter für die Programmierung der Tasten und Funktionen (gekennzeichnet durch ein rotes Dreieck):
DIP 1-2-3-4 für die Programmierung der Tastenfunktionen
DIP 5-6 öffnen der Programmierungen

- 2 DIP 7 für die Einstellung der Versorgungsspannung (siehe Schaltpläne und Varianten ab Seite 121) Default = OFF
- DIP 8:
ON Zusatz-Grundplatte.
OFF Haupt-Grundplatte (Default).
- 4 SW3 Wahlschalter für Modus Simplebus 1 (S1-Default) oder Simplebus 2 (S2)
- 5 CV3 CV4 Stecker für die Freigabe von Taste 1 (Schließerkontakt 24V-100mA max.).
A Taste 1 Standardrelais (Default) oder programmierbar.
B taste 1 für verschiedene Anwendungen.
- 6 CV5 Stecker zur Ausschaltung des Videosignals.
- 7 CV6 Wahlschalter für die Benutzung des Eingangs IN 1 (siehe Seite138).
- 8 Lautstärkeregelung des Lautsprechers (nur für die Einstellung der Sprechleitung der Internkommunikation).

Art. 2608

Nicht zur Nutzung der Funktion Gegensprechbetrieb verwendbar.
Die Innensprechstelle immer unter Verwendung von Art. 1214/2C, wie auf dem Anschlussplan MSK/FC auf Seite 136 dargestellt, installieren.

- 1 Anzeige Privacy.
- 2 Wahlschalter Rufon/Privacy mit 3 Stellungen:
Stellung oben: Rufon mit maximaler Lautstärke.
Mittelstellung: Rufon mit mittlerer Lautstärke.
Stellung unten: Aktivierung der Privacy-Funktion.
(Unter Privacy-Funktion ist die Deaktivierung des Rufs von der Außenstelle oder der Zentrale gemeint; die Aktivierung der Funktion Rufabschaltung wird durch das Aufleuchten einer roten LED rechts oben angezeigt).
- 3 Lautstärkereger des Mikrofons.
- 4 Mikroschalter zur Einstellung des Teilnehmercodes.
- 5 Anschlussklemmen der Anlage:
L L Anschluss an Busleitung.
CFP CFP Eingang Etagenruf.
P1 C1 Klemmen der Taste P1 für Zusatzfunktionen Schließkontakt 24V-100mA max) (CV1 und CV2 entfernen, siehe Variante SB/X3 Seite 136).
S+ S- Klemmen für Rufwiederholeinrichtung.
- 6 **CV1 CV2 Jumper sind zu entfernen, um einen potentialfreien Schließer an Taste P1 herzustellen.**
- 7A/7B JP1 Jumper zur Wahl der Funktion „Ruf an Pfortnerzentrale“ (Stellung C) bzw. Standardrelais (Stellung A) der Taste P1.

Beschreibung der Tasten:

☞ Türöffnertaste.

P1 Taste P1 Ruf an Pfortnerzentrale / allgemeine Relaissteuerung / Taste für verschiedene Funktionen auf Klemmleiste (P1 C1).

Das Gerät mit einem feuchten Tuch reinigen. Dazu keinen Alkohol oder ähnliche aggressive Substanzen verwenden.

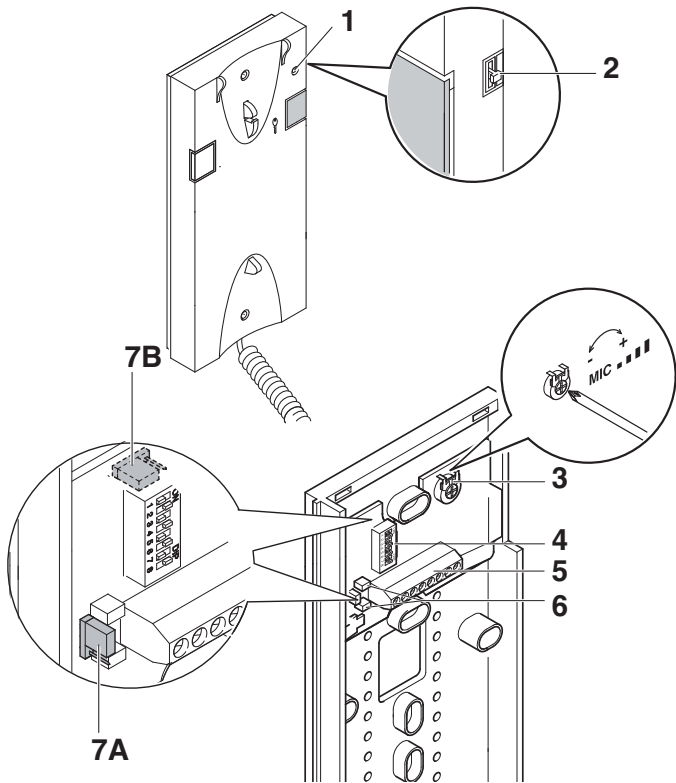

Installation der Innensprechstelle Art. 2608

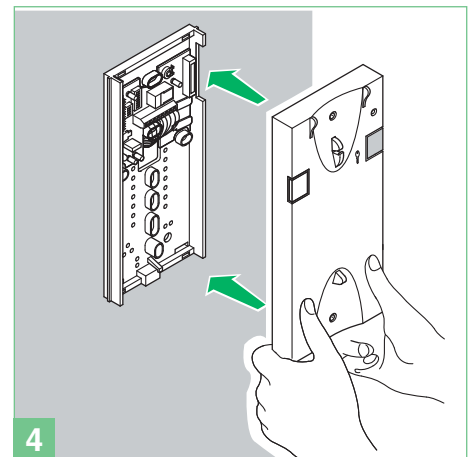
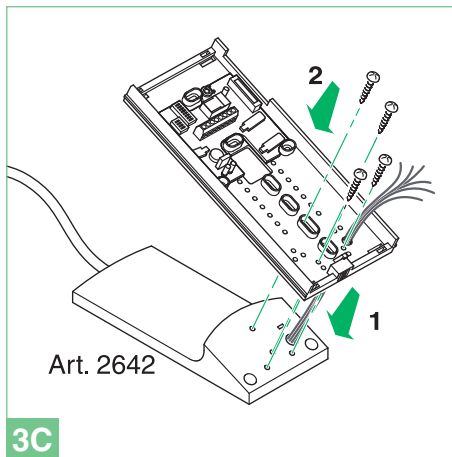
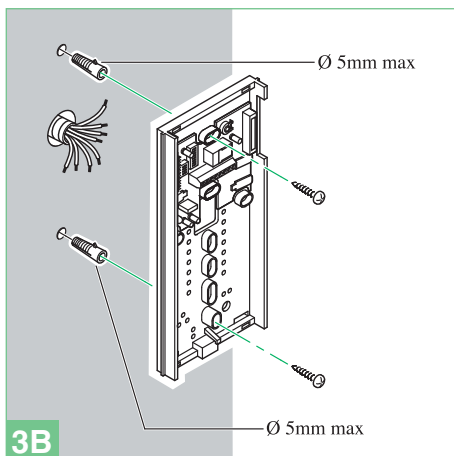
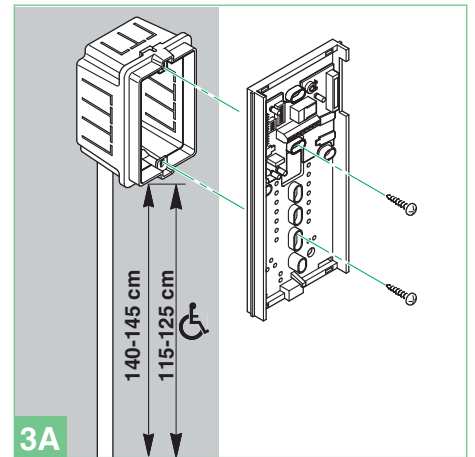
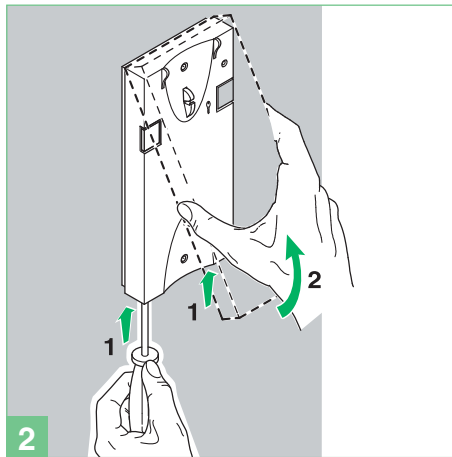
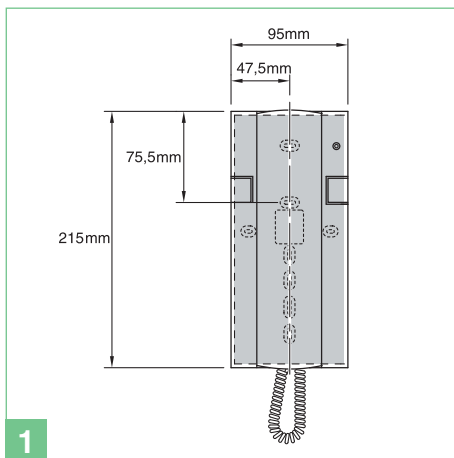

Allgemeine Installations- und Betriebshinweise

Die maximal zulässige Entfernung zwischen Außenstelle und entferntestem Monitor beträgt 400 m (mit Verstärker Art. 4833C).
 Die sich aus der Anzahl der Innenstellen mit dem gleichen Benutzercode und der Anzahl der mit diesen Innenstellen verbundenen Rufwiederholungsrichtungen ergebende Gesamtsumme darf nicht mehr als sein.
 Jeweils nur eine Rufwiederholeinrichtung pro Innensprechstelle anschließen.
 Die maximale Entfernung zwischen Innensprechstelle und Rufwiederholeinrichtung beträgt 20 m; zur Verbindung ist ein abgeschirmtes Kabel zu verwenden und die Kabel dürfen nicht in der Nähe von induktiven Belastungen oder von Stromkabeln (230V/400V) verlegt werden.

Tabelle der zulässigen Entfernungen der Geräte

		A/G MAX	B/E MAX	C MAX	D MAX	F MAX	Art. 1216
Comelit Art. 4577 1 mm ² (Ø 1,2 mm AWG 17)		50 m (165 feet)	50 m (165 feet)	200 m (655 feet)	100 m (330 feet)	150 m (495 feet)	
Comelit Art. 4576-4578	0,5 mm ² (Ø 0,8 mm AWG 20) bus		25 m (85 feet)	200 m (655 feet)	100 m (330 feet)	150 m (495 feet)	
	1,5 mm ² (Ø 1,4 mm AWG 15) power	75 m (245 feet)	100 m (330 feet)				
UTP5 cat. 5 0,2 mm ² (Ø 0,5 mm AWG 24)				190 m (625feet)	60 m (195 feet)	150 m (495 feet)	
0,28 mm ² (Ø 0,6 mm AWG 23)		5 m (15 feet)		190 m (625 feet)	60 m (195 feet)	150 m (495 feet)	
0,5 mm ² (Ø 0,8 mm AWG 20)		25 m (85 feet)	25 m (85 feet)	190 m (625 feet)	60 m (195 feet)	150 m (495 feet)	
1 mm ² (Ø 1,2 mm AWG 17)		50 m (165 feet)	50 m (165 feet)	190 m (625 feet)	60 m (195 feet)	150 m (495 feet)	
1 mm ² (Ø 1,2 mm AWG 17)		50 m (165 feet)	50 m (165 feet)	120 m (395 feet)	40 m (130 feet)	100 m (330 feet)	
1,5 mm ² (Ø 1,4 mm AWG 15)		75 m (245 feet)	100 m (330 feet)	190 m (625 feet)	60 m (195 feet)	150 m (495 feet)	
2,5 mm ² (Ø 1,8 mm AWG 13)		100 m (330 feet)	150 m (495 feet)	190 m (625 feet)	60 m (195 feet)	150 m (495 feet)	

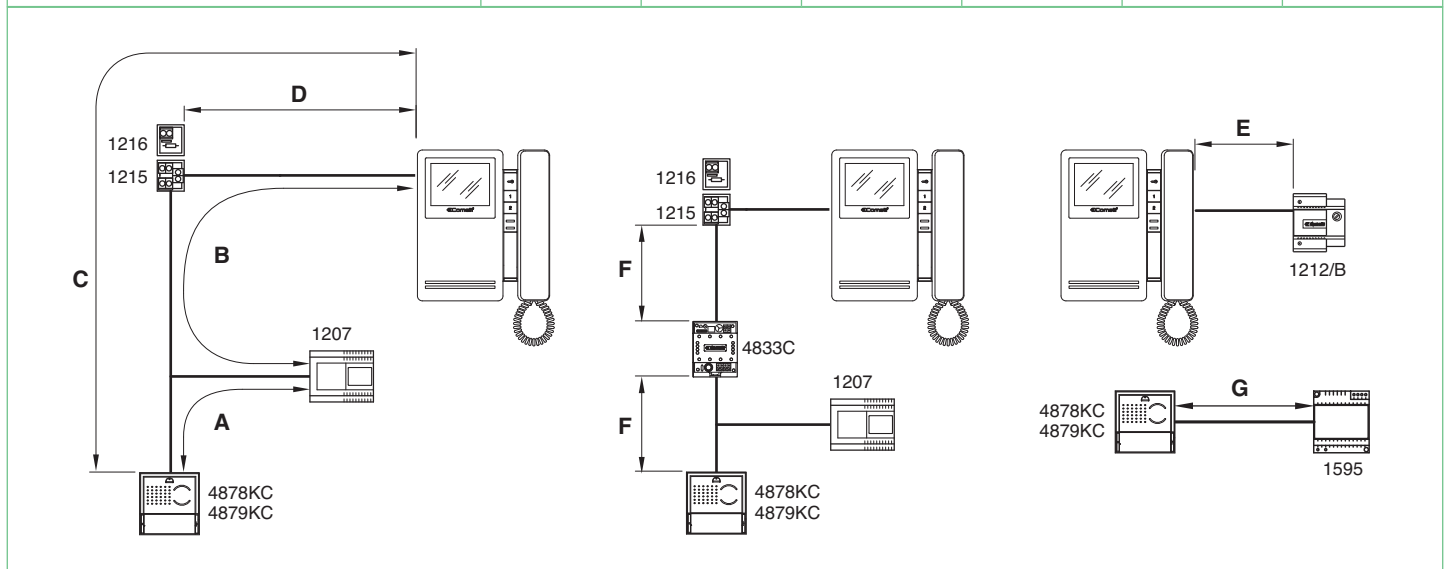

Funktionsweise



Im Falle eines anhaltenden Kurzschlusses auf der Buslinie gibt die Außenstelle einen intermittierenden Signalton aus.

Durch Drücken der Ruftaste schaltet der Besucher die Beleuchtung des Motivs ein, löst den Rufton der Innensprechstelle aus (insofern die Privacy-Funktion nicht aktiviert ist) und lässt sein Bild für ca. 60 Sek. auf dem/den Hauptmonitor/en erscheinen.
 Die maximale Gesprächsdauer zwischen Außenstelle und Innensprechstelle beträgt 90 Sekunden.
 An der Außenstelle ist ein Ton zu hören, mit dem der erfolgte Ruf bestätigt wird; ist bei Anlagen mit zwei oder mehreren Eingängen zum Zeitpunkt des Rufs ein Besetztzeichen anstelle der Wiederholung des Ruftons zu hören, bedeutet dies, dass bereits eine Kommunikation mit einer anderen Außenstelle stattfindet.
 Für die Programmierung von anderen als den werkseitig eingestellten Benutzeradressen (1 und 2) siehe Seite 77.
 Für die Intercom-Funktionen des Systems Magis Kit siehe Seite 80.

Beschreibung Tasteneinstellungen und -funktionen

Einstellungen Monitor Art. 6402E und Innensprechstelle Style

Stellung der Mikroschalter des Monitors Art. 6402E

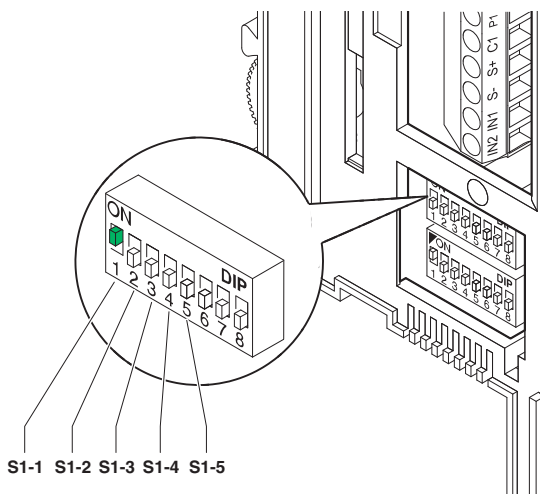

► An den Innensprechstellen Art. 2608, Art. 2610 und Art. 2628 die Dipschalter **S1-6, S1-7, S1-8** auf **OFF** setzen.

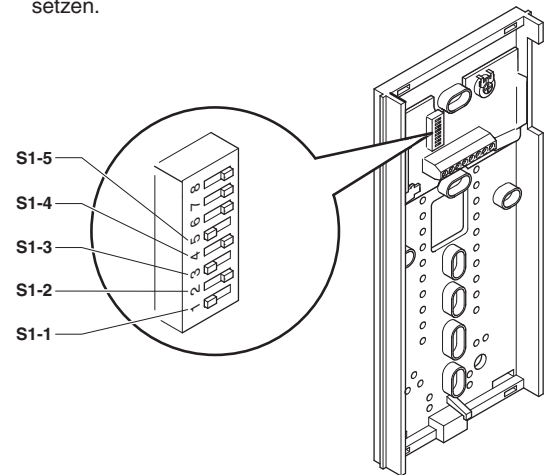

Die Werte **S1-1, S1-2, S1-3, S1-4** und **S1-5** definieren die **Rufadresse** des Monitors und der Innensprechstellen gemäß folgender Tabelle.

TAB. A Adressen der Steigleitung

Code	S1	Code	S1	Code	S1	Code	S1
1		9		17		25	
2		10		18		26	
3		11		19		27	
4		12		20		28	
5		13		21		29	
6		14		22		30	
7		15		23			
8		16		24			

Beschreibung der Tastenfunktionen

Interngespräche bei Zweifamiliensets (zwischen Sprech- und/oder Videosprechgeräten) sind nur möglich, wenn die beiden Benutzer auf benachbarte Rufcodes programmiert sind (gekennzeichnet durch den gleichen Buchstaben AA..CC..OO in der Programmiertabelle der Mikroschalter auf Seite 77).

☞ **Türöffner:** Durch Drücken der Türöffnertaste aktiviert sich das mit der Außenstelle verbundene Schloss.

Antrieb: Durch Drücken der auf die Betriebsart Antrieb eingestellten Taste lässt sich Art. 1256 aktivieren, der zum Beispiel zur Öffnung von Toren, Kipptoren oder zur Aktivierung des Moduls zyklische Videokameras Art. 1259C genutzt werden kann.

Unbelegte Taste Die Angabe Unbelegte Taste weist auf die Möglichkeit hin, die Taste als Schließkontakt an der Klemmenleiste nach entsprechenden Einstellungen, wie in der Variante SB2/AAM2 auf Seite 139 dargestellt, zu nutzen.

Selbsteinschaltung / Video-Anforderung

Die Selbst-einschaltung kann deaktiviert werden.

Die Selbst-einschaltung ist nur möglich, wenn sich die Anlage in

Standby befindet.

Die Funktion Selbst-einschaltung wird nur für Anlagen mit 1 oder 2 Eingängen empfohlen.

Durch Drücken der auf diese Betriebsart eingestellten Taste 2 lässt sich das von der Außenstelle gesendete Bild am Bildschirm anzeigen, auch wenn kein Ruf getätigt wurde.

Bei Anlagen mit 2 Außenstellen lässt sich abwechselnd das Bild der einen oder der anderen Außenstelle ('Pendelfunktion') anzeigen, indem die Taste 2 mehrmals nacheinander gedrückt wird.

An den Zusatzmonitoren (DIP 8 von S2 auf ON) hat die Taste 2 auch die Funktion der Video-Anforderung und dient zum Einschalten eines Monitors nach einem Ruf von der Außenstelle.

Aktivierung:

► Die Selbst-einschalttaste des Monitors länger als 4 Sek. gedrückt halten.
» Klingelton zur Bestätigung.

Deaktivierung:

► Die Selbst-einschalttaste des Monitors länger als 4 Sek. gedrückt halten.

» 4 Bestätigungstöne

Einschaltung:

► Die entsprechende Taste (Taste 2, falls die werkseitigen Einstellungen beibehalten wurden) drücken und sofort wieder loslassen.

Ruf an Pförtnerzentrale

Durch Drücken der auf diese Betriebsart eingestellten Taste lässt sich ein Ruf an die Pförtnerzentrale senden.

Einfamilienhaus-Internruf

Diese Funktion ermöglicht, einen Ruf an die anderen Geräte (Video- und /oder Innensprechstellen) zu tätigen, die auf dieselbe Rufadresse eingestellt sind.

► Wenn der Empfänger des Anrufs den Hörer abnimmt, nimmt er mit dem Anrufer Verbindung auf. Durch Auflegen des Hörers wird die Kommunikation beendet.

Interngespräche haben keinen Vorrang vor einem Gespräch/Ruf mit der Außenstelle. In diesem Fall blinkt bei einem versuchten Interngespräch die LED für einige Sekunden, um zu melden, dass das System besetzt ist.

Anrufen von einer Außenstelle

Ein von einer Außensprechstelle eingehender Anruf hat jedoch zu jeder Zeit Vorrang vor einem Interngespräch. (Die Aufnahme des Gesprächs mit der Außenstelle unterbricht das zuvor laufende Interngespräch).

In diesem Fall vernehmen die bereits an einem Gespräch beteiligten

Benutzer einen Ton, der dem eines an sie gerichteten Rufs ähnelt, oder andernfalls drei Signaltöne.

► Um den von der Außenstelle eingehenden Ruf anzunehmen, nur den Hörer von jedem beliebigen freien Gerät abnehmen oder den Hörer von einem am Interngespräch beteiligten Gerät abnehmen und wieder auflegen.

Arztruf

Diese Funktion gestattet die automatische Betätigung des Türöffners bei Ruf von der Außenstelle an die Adresse der Innensprechstelle, an der die Funktion aktiviert wurde.

Aktivierung / Deaktivierung:

► Die auf diese Funktion eingestellte Taste 2 Sek. lang gedrückt halten »Bei aktivierter Funktion bleibt die Anzeige-LED eingeschaltet.

Zusätzliche Haupt- oder Nebenmonitore

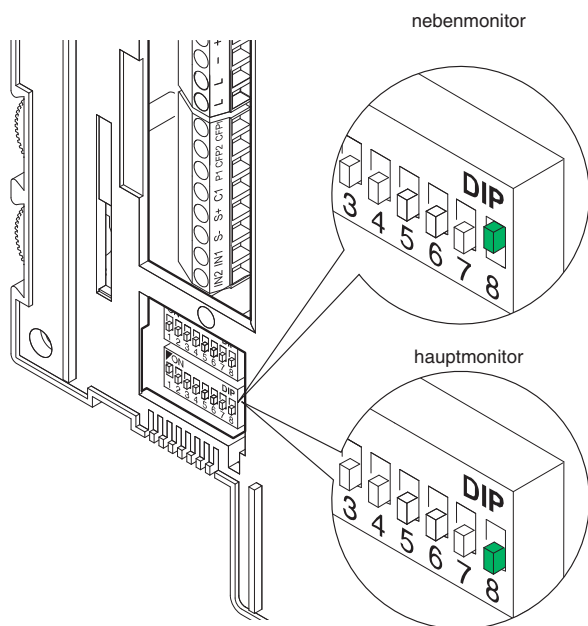

Mit der Einstellung des DIP-Schalters 8 von S2 wird festgelegt, ob die betreffende Grundplatte als Haupt- (P) oder Nebensprechstelle (S) verwaltet wird.

Die Außenstelle ist für die Steuerung von maximal 4 Videosprech- oder Innensprechstellen pro Ruftaste ausgelegt.

In der klassischen Konfiguration von Magis Kit können demnach maximal 2 Haupt-Videosprechstellen und 2 Neben-Videosprechstelle je Ruftaste installiert werden, deren Versorgung stets durch den **Art. 1207** erfolgt.

Es besteht die Möglichkeit, bis zu 3 Haupt-Videosprechstellen innerhalb der gleichen Wohnung (d.h. mit Einstellung auf den gleichen Teilnehmercode) zu steuern. In dieser besonderen Konfiguration müssen die zusätzlichen Haupt-Videosprechstellen von dem hierfür vorgesehenen **Art. 1212/B** versorgt werden (siehe Variante MSK/HCA, MSK/IC Seite 132, 133).

Geht ein Ruf von der Außenstelle aus, ist der eingeschaltete Monitor die Haupt-Videosprechstelle.

Die eventuell vorhandenen Nebenmonitore der gleichen Wohnung bleiben ausgeschaltet.

Wird der Ruf der Außenstelle von einer Nebenvideosprechstelle beantwortet, erscheint das Bild automatisch am Monitor.

Nun wird der Monitor der Haupt-Videosprechstelle ausgeschaltet und das Bild am Monitor der Videosprechstelle angezeigt, deren Taste 2 - Selbsteinschaltung/Video-Anforderung gedrückt wird.

Zur Anzeige des Bildes ohne Aktivierung der Sprechverbindung mit der Außenstelle die Taste 2 - Selbsteinschaltung/Video-Anforderung drücken.

Verwendung des Sets in Anlagen mit Haupttür

Die Anschlusspläne MSK/EN/109IC, MSK/EN/110IC auf Seite 128, 131 stellen eine Anlagenkonfiguration dar, die die Möglichkeit bietet, bis zu maximal 30 Magis Kit durch einen zum Beispiel am Eingang eines Wohnkomplexes installierten Art. 4680C - Art. 4680KC* steuern zu lassen. Bei Verwendung dieser Anlagenpläne kann eines der Magis Kit von dem mit Art. 4680C - Art. 4680KC* ausgestatteten Haupteingang angerufen werden.

In dieser Konfiguration müssen die Tasten von Art. 4680KC am Art. 4879KC wie nachstehend beschrieben, und die Innensprechstellen mit dem

entsprechenden Code programmiert werden, siehe Tabelle auf Seite 77. Nähere Informationen über den Einbau der Magis Kit in Simplebus Anlagen und die Programmierung der Haupttür (Art. 4680C - Art. 4680KC*) finden Sie im Katalog (Nr. 140), im technischen Handbuch cod. 2G40000472.

* Verwendungseinschränkungen Art. 4680KC

Der Art. 4680KC verwaltet die von den Tasten- oder digitalen Rufmodulen eingehenden Anrufe **NUR**, wenn sie zwischen der Adresse 1 und der Adresse 10 liegen.

Programmierung der Tasten Art. 4680KC

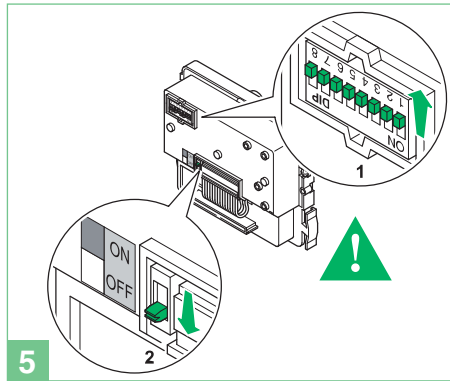
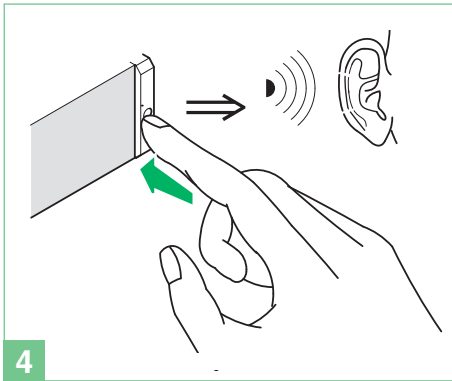
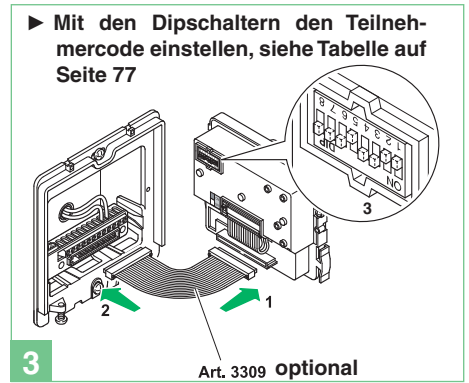
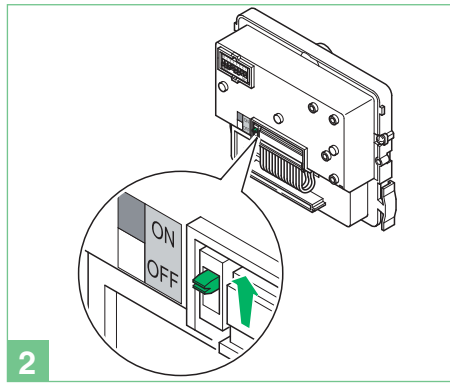
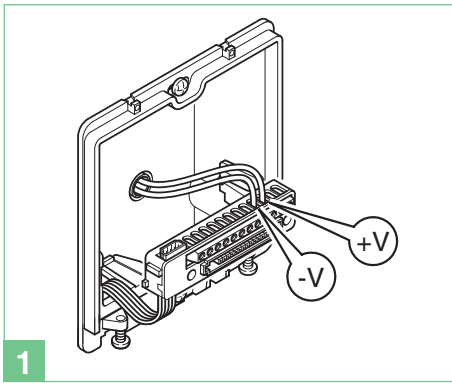

DE

Default-Tastenkonfiguration

DIP S2								mit Art. 6433, 6434			
DIP 1	DIP 2	DIP 3	DIP 4	P1	P2			P3	P4	P5	P6
0	0	0	0	CCS	AI			ACT	D	PAN	K
1	0	0	0	ACT	AI			INT	INTb	D	CCS
0	1	0	0	INT	AI			INTb	ACT	CCS	CCP
1	1	0	0	ACT	CCS			CCP	PAN	K	D
0	0	1	0	ACT	ACT	ACT		ACT	ACT	ACT	ACT
1	0	1	0	INT	ACT			CCS	CCP	INTb	PAN
0	1	1	0	AI	D			K	CCS	CCP	INTb
1	1	1	0	INTb	INT			AI	INT	PAN	D
0	0	0	1	CCS	PAN			D	AI	INT	INTb
1	0	0	1	K	CCS			PAN	CCP	AI	INT
0	1	0	1	CCP	K			PAN	ACT	INT	AI
1	1	0	1	PAN	CCP			CCS	K	ACT	D
0	0	1	1	D	INTb			INT	ACT	AI	CCS
1	0	1	1	INT	INT			INT	INT	INT	INT
0	1	1	1	NULL	NULL	NULL	NULL	NULL	NULL	NULL	NULL
1	1	1	1						PROG		

Legende

	Türöffnertaste	CCS	Ruf an Pfortnerzentrale	INTb	Intercom Zweifamilienhaus - nur für KIT
	Sprechverbindung	K	Ruf an Wechselsprechergerät des Wachmanns	NULL	Keine Funktion
ACT	Relais	D	Arztruf	PROG	Programmierte Funktionen beschrieben, siehe Seiten 79-80-81-82. In dieser Stellung der DIP-Schalter betätigen die Tasten die programmierten Funktionen; Die NICHT programmierten Tasten betätigen die Funktionen der Zeile 0000
AI	Selbsteinschaltung	PAN	Notruf		
CCP	Ruf an Haupt-Pfortnerzentrale	INT	Intercom programmierbar allgemein oder selektiv - serienmäßig Ruf Einfamilienhaus für KIT und Simplebus Top		

! Allgemeine Hinweise zur Tastenprogrammierung

Falls die Default-Konfigurationen (siehe Tabelle auf Seite 79) nicht den Anforderungen entsprechen, können die Tasten wie nachstehend beschrieben umprogrammiert werden.

Am Schluss die DIP-Schalter 1-2-3-4 von S2 auf Kombination 1111 stellen (Einstellung PROG in den Konfigurations-Tabellen Seite 79-80-81-82). Wenn die DIP-Schalter so eingestellt sind, betätigen die Tasten die

programmierten Funktionen; die NICHT programmierten Tasten betätigen die Funktionen der Zeile 0000 (siehe Tabelle Seite 79). Die Einstellung des Benutzercodes auf S1 wieder herstellen, siehe Tabelle A auf Seite 77.

Tastenprogrammierung für allgemeine oder codierte Relaissteuerung

DIP S2				mit Art. 6433, 6434						DIP S1			
DIP 1	DIP 2	DIP 3	DIP 4	P1	P2			P3	P4	P5	P6	ADRESSE 1 2 3 4 5 6 7 8	
0	0	0	0					ACT					
1	0	0	0	ACT									
0	1	0	0						ACT				
1	1	0	0	ACT									
0	0	1	0	ACT	ACT	ACT		ACT	ACT	ACT	ACT		
1	0	1	0		ACT								
0	1	1	0										
1	1	1	0										
0	0	0	1										
1	0	0	1						ACT				
0	1	0	1							ACT			
1	1	0	1										
0	0	1	1										
1	0	1	1										
0	1	1	1										
1	1	1	1										

Beispiel:

Am Monitor mit Benutzercode 5 Programmierung P1= allgemeine Relaissteuerung, P2= codierte Relaissteuerung mit Code 125.

- DIP-Schalter 5-6 von S2 auf die Kombination 01 stellen.
» Die (grüne) LED blinkt.
- In der Tabelle auf Seite 80 eine Kombination wählen, in der für die Tasten, die programmiert werden sollen, die Funktion Relais (ACT) erscheint.

BEISPIEL: Für P1= allgemeine Relaissteuerung die DIP-Schalter 1-2-3-4 von S2 auf die Kombination 1000 oder 1100 oder 0010 (P1=ACT) stellen, DIP-Schalter von S1 auf die Kombination 11111111 stellen, weiter mit Punkt 3.

BEISPIEL: Für P2= Codierte Relaissteuerung mit Code 125 die DIP-Schalter 1-2-3-4 von S2 auf die Kombination 0010 oder 1010 (P2=ACT)

stellen, S1 gemäß **Tabelle C** auf Seite 82 mit Adresse 125 einstellen, weiter mit Punkt 3.

- Die Taste, der die Funktion zugewiesen werden soll, drücken und gedrückt halten.
» Die (grüne) LED leuchtet auf.
» Bestätigungston im Hörer.
- Zum Beenden der Programmierung die DIP-Schalter 5-6 von S2 auf die Kombination 00 stellen.
» Die (grüne) LED erlischt.
- Am Ende der Programmierung die DIP-Schalter 1-2-3-4 von S2 auf die Kombination 1111 stellen. Die Einstellung des Benutzercodes auf S1 wieder herstellen, siehe Tabelle C auf Seite 82.

DE

Programmierungen für Interngespräch



Allgemeine und selektive Intercom-Verbindungen sind **NICHT** an derselben Steigleitung möglich.

Programmierung/Löschung der Intercom-Adresse (nur für selektive Intercom-Verbindung)

	! 2)						3)	
S1	DIP 1	DIP 2	DIP 3	DIP 4	DIP 5	DIP 6	S2	
Programmierung; eingabe des Codes, TAB. B seite 80	0	0	0	1	1	1	 	
Löschen	1	1	1	1	1	1	 	 2 sek



Die Einstellung von **S2, S1** notieren und nach Abschluss der Programmierung wieder herstellen.

TAB. B Adressen für selektive Intercom-Verbindung

Code	Dip switch ON	S1	Code	Dip switch ON	S1	Code	Dip switch ON	S1
1	1		4	4		7	7	
2	2		5	5		8	8	
3	3		6	6				

Die Intercom-Adresse muss an allen Innensprechstellen der Steigleitung eingerichtet werden. Dieselbe Intercom-Adresse kann maximal 3 Innensprechstellen zugeordnet werden. Für den Gruppenruf die gewünschten Intercom-Codes gleichzeitig wählen (max. 3).

Tastenprogrammierung für Interngespräch

DIP S2								mit Art. 6433, 6434				DIP S1	
DIP 1	DIP 2	DIP 3	DIP 4	P1	P2			P3	P4	P5	P6	ADRESSE 	
0	0	0	0										
1	0	0	0					INT	INTb				
0	1	0	0	INT				INTb					
1	1	0	0										
0	0	1	0										
1	0	1	0	INT						INTb			
0	1	1	0								INTb		
1	1	1	0	INTb	INT				INT				
0	0	0	1							INT	INTb		
1	0	0	1								INT		INT
0	1	0	1							INT			
1	1	0	1										
0	0	1	1		INTb			INT					
1	0	1	1	INT	INT			INT	INT	INT	INT		
0	1	1	1										
1	1	1	1										
PROG													

Beispiel 1 - Selektivem Internruf

Am Monitor mit Benutzercode 1 und Intercom-Adresse 1 Programmierung P3= Intercom selektiv mit Adresse 2, P4= Intercom selektiv mit Adresse 3.

Beispiel 2 - Internruf KIT (Intercom-Verbindung zwischen 2 benachbarten Adressen von 1 bis 30, davon die erste ungerade):

Am Monitor mit Benutzercode 1 Programmierung P3= Interner Gruppenruf, P4= Intercom Zweifamilienhaus mit Adresse 2.

1. DIP-Schalter 5-6 von S2 auf die Kombination 01 stellen.
» Die (grüne) LED blinkt.

2. In der Tabelle auf Seite 81 eine Kombination wählen, in der für die Tasten, die programmiert werden sollen, die Funktion Intercom (INT oder INTb) erscheint.

BEISPIEL 1: Für P3= Intercom selektiv die DIP-Schalter 1-2-3-4 von S2 auf die Kombination 1000 oder 0011 oder 1011 (P3=INT) stellen, S1 gemäß **Tabelle B** auf Seite 80 mit Adresse 2 einstellen, weiter mit Punkt 3.

BEISPIEL1: Für P4= Intercom selektiv die DIP-Schalter 1-2-3-4 von S2 auf die Kombination 1110 oder 1011 (P4=INT) stellen, S1 gemäß **Tabelle**

B auf Seite 80 mit Adresse 3 einstellen, weiter mit Punkt 3.

BEISPIEL 2: Für P3= Interner Gruppenruf und P4= Intercom Zweifamilienhaus die DIP-Schalter 1-2-3-4 von S2 auf die Kombination 1000 (P3=INT, P4=INTb) stellen, S1 gemäß **Tabelle A** auf Seite 77 mit Benutzercode 1 einstellen, weiter mit Punkt 3.

3. Die Taste, der die Funktion zugewiesen werden soll, drücken und gedrückt halten.

» Die (grüne) LED leuchtet auf.
» Bestätigungston im Hörer.

4. Zum Beenden der Programmierung die DIP-Schalter 5-6 von S2 auf die Kombination 00 stellen.

» Die (grüne) LED erlischt.

5. Am Ende der Programmierung die DIP-Schalter 1-2-3-4 von S2 auf die Kombination 1111 stellen. Die Einstellung des Benutzercodes auf S1 wieder herstellen, siehe **Tabelle A** auf Seite 77.

DE

Tastenprogrammierung für andere Funktionen

DIP S2								mit Art. 6433, 6434			
DIP 1	DIP 2	DIP 3	DIP 4	P1	P2			P3	P4	P5	P6
0	0	0	0	CCS	AI				D	PAN	K
1	0	0	0		AI					D	CCS
0	1	0	0		AI					CCS	CCP
1	1	0	0		CCS			CCP	PAN	K	D
0	0	1	0								
1	0	1	0								
0	1	1	0	AI	D			CCS	CCP	CCP	PAN
1	1	1	0					AI	CCS	PAN	D
0	0	0	1	CCS	PAN			D	AI		
1	0	0	1	K	CCS			PAN	CCP	AI	
0	1	0	1	CCP	K			PAN			AI
1	1	0	1	PAN	CCP			CCS	K		D
0	0	1	1	D						AI	CCS
1	0	1	1								
0	1	1	1	NULL	NULL	NULL	NULL	NULL	NULL	NULL	NULL
1	1	1	1								
PROG											

Legende

	Turöffnertaste	CCS	Ruf an Pförtnerzentrale	NULL	Keine Funktion
	Sprechverbindung	K	Ruf an Wechselsprechgerät des Wachmanns	PROG	Programmierte Funktionen
AI	Selbsteinschaltung	D	Arztruf		
CCP	Ruf an Haupt-Pförtnerzentrale	PAN	Notruf		

Beispiel:

Am Monitor mit Benutzercode 5 Programmierung P5= Selbsteinschaltung, P6= Ruf an Pförtnerzentrale.

1. DIP-Schalter 5-6 von S2 auf die Kombination 01 stellen.
» Die (grüne) LED blinkt.

2. In der Tabelle auf Seite 81 eine Kombination wählen, in der die gewünschten/erforderlichen Funktionen für die zu programmierenden Tasten erscheinen.

BEISPIEL: Für P5= Selbsteinschaltung P6= Ruf an Pförtnerzentrale die DIP-Schalter 1-2-3-4 von S2 auf die Kombination 0011 stellen (P5=AI, P6=CCS).

3. Die Taste, der die Funktion zugewiesen werden soll, drücken und gedrückt halten.

» Die (grüne) LED leuchtet auf.
» Bestätigungston im Hörer.

4. Zum Beenden der Programmierung die DIP-Schalter 5-6 von S2 auf die Kombination 00 stellen.

» Die (grüne) LED erlischt.

5. Am Ende der Programmierung die DIP-Schalter 1-2-3-4 von S2 auf die Kombination 1111 stellen.

TAB. C Adressen der Steigleitung

Code	Dip switch ON	Code	Dip switch ON	Code	Dip switch ON	Code	Dip switch ON	Code	Dip switch ON	Code	Dip switch ON	Code	Dip switch ON	Code	Dip switch ON
1	1	31	1,2,3,4,5	61	1,3,4,5,6	91	1,2,4,5,7	121	1,4,5,6,7	151	1,2,3,5,8	181	1,3,5,6,8	211	1,2,5,7,8
2	2	32	6	62	2,3,4,5,6	92	3,4,5,7	122	2,4,5,6,7	152	4,5,8	182	2,3,5,6,8	212	3,5,7,8
3	1,2	33	1,6	63	1,2,3,4,5,6	93	1,3,4,5,7	123	1,2,4,5,6,7	153	1,4,5,8	183	1,2,3,5,6,8	213	1,3,5,7,8
4	3	34	2,6	64	7	94	2,3,4,5,7	124	3,4,5,6,7	154	2,4,5,8	184	4,5,6,8	214	2,3,5,7,8
5	1,3	35	1,2,6	65	1,7	95	1,2,3,4,5,7	125	1,3,4,5,6,7	155	1,2,4,5,8	185	1,4,5,6,8	215	1,2,3,5,7,8
6	2,3	36	3,6	66	2,7	96	6,7	126	2,3,4,5,6,7	156	3,4,5,8	186	2,4,5,6,8	216	4,5,7,8
7	1,2,3	37	1,3,6	67	1,2,7	97	1,6,7	127	1,2,3,4,5,6,7	157	1,3,4,5,8	187	1,2,4,5,6,8	217	1,4,5,7,8
8	4	38	2,3,6	68	3,7	98	2,6,7	128	8	158	2,3,4,5,8	188	3,4,5,6,8	218	2,4,5,7,8
9	1,4	39	1,2,3,6	69	1,3,7	99	1,2,6,7	129	1,8	159	1,2,3,4,5,8	189	1,3,4,5,6,8	219	1,2,4,5,7,8
10	2,4	40	4,6	70	2,3,7	100	3,6,7	130	2,8	160	6,8	190	2,3,4,5,6,8	220	3,4,5,7,8
11	1,2,4	41	1,4,6	71	1,2,3,7	101	1,3,6,7	131	1,2,8	161	1,6,8	191	1,2,3,4,5,6,8	221	1,3,4,5,7,8
12	3,4	42	2,4,6	72	4,7	102	2,3,6,7	132	3,8	162	2,6,8	192	7,8	222	2,3,4,5,7,8
13	1,3,4	43	1,2,4,6	73	1,4,7	103	1,2,3,6,7	133	1,3,8	163	1,2,6,8	193	1,7,8	223	1,2,3,4,5,7,8
14	2,3,4	44	3,4,6	74	2,4,7	104	4,6,7	134	2,3,8	164	3,6,8	194	2,7,8	224	6,7,8
15	1,2,3,4	45	1,3,4,6	75	1,2,4,7	105	1,4,6,7	135	1,2,3,8	165	1,3,6,8	195	1,2,7,8	225	1,6,7,8
16	5	46	2,3,4,6	76	3,4,7	106	2,4,6,7	136	4,8	166	2,3,6,8	196	3,7,8	226	2,6,7,8
17	1,5	47	1,2,3,4,6	77	1,3,4,7	107	1,2,4,6,7	137	1,4,8	167	1,2,3,6,8	197	1,3,7,8	227	1,2,6,7,8
18	2,5	48	5,6	78	2,3,4,7	108	3,4,6,7	138	2,4,8	168	4,6,8	198	2,3,7,8	228	3,6,7,8
19	1,2,5	49	1,5,6	79	1,2,3,4,7	109	1,3,4,6,7	139	1,2,4,8	169	1,4,6,8	199	1,2,3,7,8	229	1,3,6,7,8
20	3,5	50	2,5,6	80	5,7	110	2,3,4,6,7	140	3,4,8	170	2,4,6,8	200	4,7,8	230	2,3,6,7,8
21	1,3,5	51	1,2,5,6	81	1,5,7	111	1,2,3,4,6,7	141	1,3,4,8	171	1,2,4,6,8	201	1,4,7,8	231	1,2,3,6,7,8
22	2,3,5	52	3,5,6	82	2,5,7	112	5,6,7	142	2,3,4,8	172	3,4,6,8	202	2,4,7,8	232	4,6,7,8
23	1,2,3,5	53	1,3,5,6	83	1,2,5,7	113	1,5,6,7	143	1,2,3,4,8	173	1,3,4,6,8	203	1,2,4,7,8	233	1,4,6,7,8
24	4,5	54	2,3,5,6	84	3,5,7	114	2,5,6,7	144	5,8	174	2,3,4,6,8	204	3,4,7,8	234	2,4,6,7,8
25	1,4,5	55	1,2,3,5,6	85	1,3,5,7	115	1,2,5,6,7	145	1,5,8	175	1,2,3,4,6,8	205	1,3,4,7,8	235	1,2,4,6,7,8
26	2,4,5	56	4,5,6	86	2,3,5,7	116	3,5,6,7	146	2,5,8	176	5,6,8	206	2,3,4,7,8	236	3,4,6,7,8
27	1,2,4,5	57	1,4,5,6	87	1,2,3,5,7	117	1,3,5,6,7	147	1,2,5,8	177	1,5,6,8	207	1,2,3,4,7,8	237	1,3,4,6,7,8
28	3,4,5	58	2,4,5,6	88	4,5,7	118	2,3,5,6,7	148	3,5,8	178	2,5,6,8	208	5,7,8	238	2,3,4,6,7,8
29	1,3,4,5	59	1,2,4,5,6	89	1,4,5,7	119	1,2,3,5,6,7	149	1,3,5,8	179	1,2,5,6,8	209	1,5,7,8	239	1,2,3,4,6,7,8
30	2,3,4,5	60	3,4,5,6	90	2,4,5,7	120	4,5,6,7	150	2,3,5,8	180	3,5,6,8	210	2,5,7,8	*240	5,6,7,8











*HINWEIS: Teilnehmercode 240 ist für die Pfortnerzentrale reserviert

Reset de Programmierung

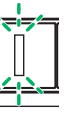
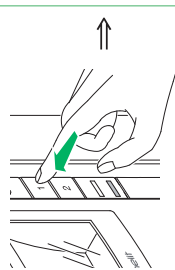
1)	2)						3)		4)	
S1	DIP 1	DIP 2	DIP 3	DIP 4	DIP 5	DIP 6	S2	S1/S2/LED1		
<p>DIP ON</p>	1	1	1	1	1	1		<p>5 sek</p>	<p>2 sek</p>	<p>Die Einstellung von S2, S1 notieren und nach Abschluss der Programmierung wieder herstellen.</p>
<p>Werkseitige Voreinstellungen:</p> <ul style="list-style-type: none"> • Tastenfunktionen abhängig von der Kombination DIP 1-2-3-4 von S2; • Keine Intercom-Adresse; • Keine Funktion Bereich und niedrigste/höchste Adressen; • Reset der Ruftöne; • Eingang IN 1 ⇒ LED (Default). 										

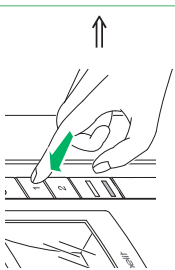
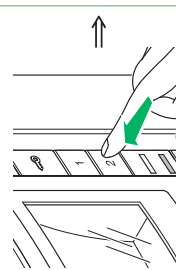
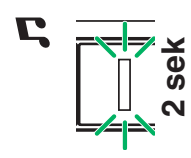
Die Arbeitsschritte 1 bis 4 ausführen

Programmierung range/Ruftöne	! 1)		! 2)						3)		4)
	S1	S2	DIP 1	DIP 2	DIP 3	DIP 4	DIP 5	DIP 6	S1/S2/LED1		
Niedrigste Adresse Bereich	eingabe des Codes, TAB. C seite 82										Die Einstellung von S2, S1 notieren und nach Abschluss der Programmierung wieder herstellen
Höchste Adresse Bereich			0	0	0	0	1	0			
Aktivierung Bereich											
Deaktivierung Bereich											
Wahl Mehrklang-Läutwerk			0	1	0	1	1	0			
Wahl Töne-Läutwerk (Default)			0	1	0	1	1	0			

Die Arbeitsschritte 1 bis 4 ausführen							
		! 2)		3)		4)	
! 1)						S1/S2/LED1	
S1		S2					
DIP 1		DIP 2		DIP 3		DIP 4	
DIP 5		DIP 6					
Programmierung Eingang IN1 für Meldung LED/ Alarm/Türöffner/Relais							
Eingang IN 1 ⇒ LED (Default), siehe auf S. 138							
Eingang IN 1 ⇒ ALARM, siehe auf S. 138			0	0	0	1	
Eingang IN 1 ⇒ TURÖFFNERTASTE, siehe auf S. 138							
Eingang IN 1 ⇒ CODIERTE RELAISSTEUERUNG, siehe auf S. 138	eingabe des Codes, TAB. C seite 82		0	0	1	0	
Eingang IN 1 ⇒ ALLGEMEINER AKTIVIERER, siehe auf S. 138	DIP ON 						
							
							
							
							
			Die Einstellung von S2, S1 notieren und nach Abschluss der Programmierung wieder herstellen				

Direkte Programmierung des Internrufs

Ermöglicht die Programmierung der Interngespräche direkt an den Innensprechstellen.

✓ Erfordert 2 Installateure.

Phase 1: Programmierung aufrufen

Installateur 1 und Installateur 2 führen an 2 Innensprechstellen folgende Arbeitsschritte aus:

1. Die DIP-Schalter 1-2-3-4 von S2 auf die Kombination 1111 stellen.

2. Hörer abheben.

3. Die Tasten 1 und 2 drei Sekunden lang drücken.

»Die Innensprechstelle gibt einen Signalton ab.

»Die (grüne) LED blinkt.

»Die Innensprechstelle aktiviert eine Sprechverbindung.

»Hiernach besteht eine Sprechverbindung zwischen den 2 Installateuren.

Phase 2: Programmierung des Interngesprächs

Installateur 1:

▶ Drückt die Taste, die darauf programmiert werden soll, Installateur 2 zu rufen (z.B. 2).

»Die Innensprechstelle von Installateur 1 gibt einen Bestätigungston ab.

Installateur 2:

▶ Drückt die Taste, die darauf programmiert werden soll, Installateur 1 zu rufen (z.B. 1).

»Die Innensprechstelle von Installateur 2 gibt einen Bestätigungston ab.

Installateur 1/Installateur 2:

▶ Legen Sie den Hörer.

»Die Innensprechstelle gibt einen Signalton ab.

»Die Programmierung der 2 Innensprechstellen ist hiermit abgeschlossen.

Um eine weitere Innensprechstelle zu programmieren, zu PHASE 3 wechseln.

Phase 3: Programmierung weiterer Innensprechstellen

Installateur 1/Installateur 2:

1. Führt an der neuen Innensprechstelle die Arbeitsschritte der Phase 1 aus, um die Sprechverbindung zu aktivieren.

2. Wiederholt die Arbeitsschritte der Phase 2.

ANM. Falls während der Programmierung ein Anruf eingeht, muss man den Anruf annehmen und die Programmierung anschließend fortsetzen.

Änderung der Monitor-Ruftöne

1. Die Taste  gedrückt halten, bis ein Bestätigungston zu hören ist (der Vorgang ist nur bei Anlage in Standby möglich; andernfalls blinkt die Anzeige-LED, um den Benutzer zu informieren).

2. Taste  drücken und wieder loslassen:

1 Mal (es wird ein Bestätigungston ausgegeben), um den Rufton für Anrufe von einer Außensprechstelle zu ändern.

2 Mal (es werden zwei Bestätigungstöne ausgegeben), um den Rufton für Anrufe von der Pförtnerzentrale zu ändern.

3 Mal (es werden 3 Bestätigungstöne ausgegeben), um den Rufton für Interngespräche von einer Innensprechstelle zu ändern.

4 Mal (es werden 4 Bestätigungstöne ausgegeben), um den Rufton des Etagenrufs zu ändern.

Durch erneutes Drücken der Taste  wird die oben beschriebene Sequenz wiederholt.

3. Die Taste 1 drücken und loslassen, um die verfügbaren Ruftöne nacheinander zu durchlaufen.

4. Die Taste 2 drücken, um die Wahl des zuletzt gehörten Ruftons zu bestätigen und die Betriebsart zur Ruftonänderung des Monitors (jederzeit) zu verlassen. Bei Beenden der Betriebsart zur Ruftonänderung des Monitors wird ein Bestätigungston ausgegeben.

Besondere Programmierungen Art. 4680KC

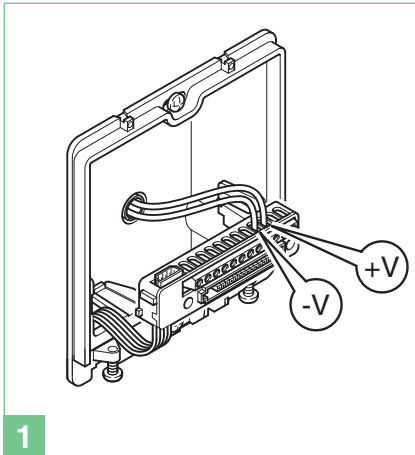

1

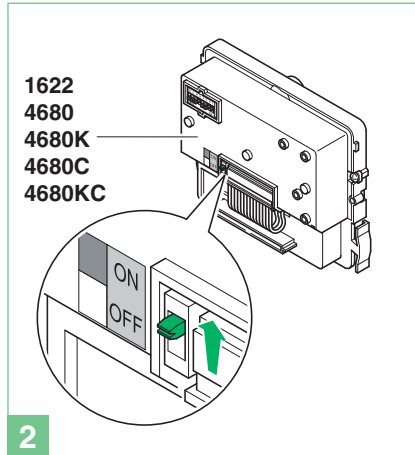

1622
4680
4680K
4680C
4680KC

2

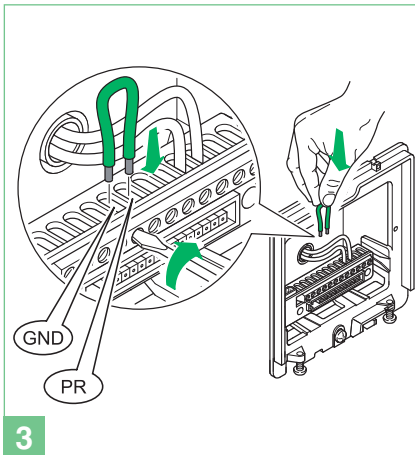

3

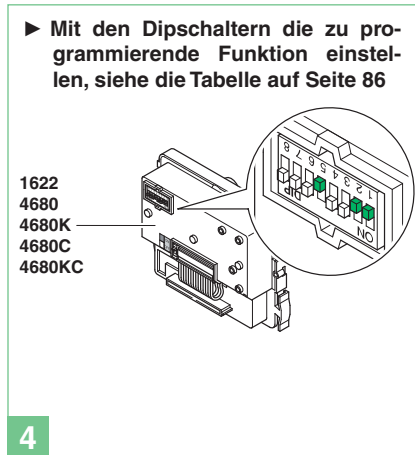

► Mit den Dipschaltern die zu programmierende Funktion einstellen, siehe die Tabelle auf Seite 86

1622
4680
4680K
4680C
4680KC

4

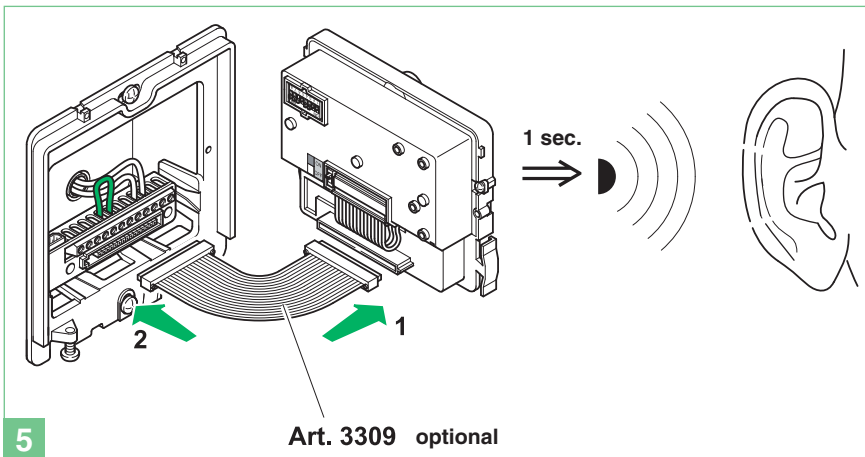

5

Art. 3309 optional

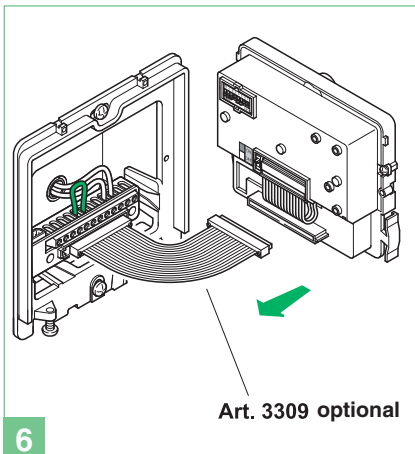

6

Art. 3309 optional

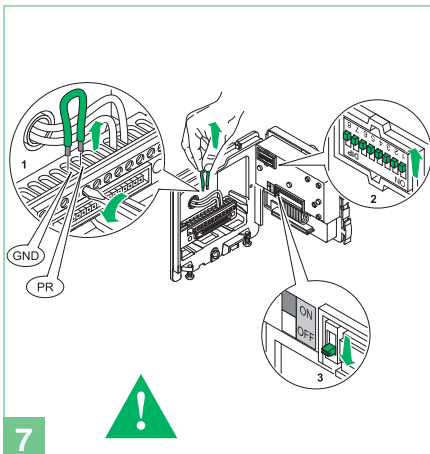

7

Code	Dip switch ON	
		Heizwiderstand zur Beschlagentfernung
213	1,3,5,7,8	OFF (Voreinstellung)
212	3,5,7,8	ON

Audiovisuelle Meldungen		
210	2,5,7,8	nur optische Anzeigen
211	1,2,5,7,8	Schwedisch
214	2,3,5,7,8	OFF (Voreinstellung)
215	1,2,3,5,7,8	Italienisch
216	4,5,7,8	Französisch
217	1,4,5,7,8	Spanisch
218	2,4,5,7,8	Niederländisch
219	1,2,4,5,7,8	Griechisch
220	3,4,5,7,8	Englisch
221	1,3,4,5,7,8	Deutsch
222	2,3,4,5,7,8	Portugiesisch

Türschloss		
223	1,2,3,4,5,7,8	Türöffnerbetätigung auf SE in Wechselfspannung (Voreinstellung)
224	6,7,8	Türöffnerbetätigung auf SE in verstärkter Wechselfspannung
225	1,6,7,8	Türöffnerbetätigung auf SE in Gleichspannung
245	1,3,5,6,7,8	Betätigungsdauer des Türöffners: 2 Sek. + Signaiton deaktiviert (Voreinstellung)
246	2,3,5,6,7,8	Betätigungsdauer des Türöffners: 4 Sek.
247	1,2,3,5,6,7,8	Betätigungsdauer des Türöffners: 8 Sek.
248	4,5,6,7,8	Türöffner-Bestätigungston: aktiv
251	1,2,4,5,6,7,8	Relais mit Öffner-/Schließerkontakt in Parallelschaltung zu SE (Voreinstellung)
252	3,4,5,6,7,8	Türöffner immer aktiviert (Voreinstellung)
253	1,3,4,5,6,7,8	Türöffner nur für angerufenen Teilnehmer aktiv

Relaisansteuerung		
Anm.: In der Anlage darf kein Art. 1256 im Standardrelais-Modus installiert sein.		
229	1,3,6,7,8	Aktivierung Öffner-/Schließerkontakt des Relais bei Relaisansteuerung: 2 Sek.
230	2,3,6,7,8	Aktivierung Öffner-/Schließerkontakt des Relais bei Relaisansteuerung: 4 Sek.
231	1,2,3,6,7,8	Aktivierung Öffner-/Schließerkontakt des Relais bei Relaisansteuerung: 8 Sek.
228	3,6,7,8	Relaisansteuerung auf serieller Leitung S: deaktiviert (Voreinstellung)
227	1,2,6,7,8	Relaisansteuerung auf serieller Leitung S: aktiv

Anlagenfunktionen		
232	4,6,7,8	Wartezeit Antwort: 60 Sek. (Voreinstellung)
233	1,4,6,7,8	Wartezeit Antwort: 120 Sek.
234	2,4,6,7,8	Wartezeit Antwort: 30 Sek.
235	1,2,4,6,7,8	Gesprächsdauer: 90 Sek. (Voreinstellung)
236	3,4,6,7,8	Gesprächsdauer: 180 Sek.
237	1,3,4,6,7,8	Selbsteinschaltung: aktiviert (Voreinstellung)
238	2,3,4,6,7,8	Selbsteinschaltung: deaktiviert
239	1,2,3,4,6,7,8	Bestätigungston bei Teilnehmerruf: aktiv (Voreinstellung)
240	5,6,7,8	Bestätigungston bei Teilnehmerruf: deaktiviert
243	1,2,5,6,7,8	Wartezeit Reset: 10 Sek. (Voreinstellung)
244	3,5,6,7,8	Wartezeit Reset: 1 Sek.
208	5,7,8	Reset nach Türöffner in Sprechverbindung: aktiv (Voreinstellung)
209	1,5,7,8	Reset nach Türöffner in Sprechverbindung: deaktiviert
249	1,4,5,6,7,8	Rufübermittlung: Einzelruf (Voreinstellung)
250	2,4,5,6,7,8	Rufübermittlung: Dreifachruf
254	2,3,4,5,6,7,8	Reset auf Voreinstellung

Advertencias

- La instalación se ha de efectuar en conformidad con las normas vigentes, siguiendo atentamente las instrucciones suministradas por el fabricante.
- Todos los aparatos deben destinarse exclusivamente al uso para el cual han sido contruidos. **Comelit Group S.p.A.** declina toda responsabilidad por el uso impropio de los aparatos, por cambios efectuados por terceros por cualquier motivo o finalidad y por el uso de accesorios y materiales no originales.
- Todos los productos son conformes a los requisitos de las Directivas 2006/95/CE (que sustituye la Directiva 73/23/CEE y sucesivas enmiendas) como demuestra la presencia de la marca **CE** en ellos.
- No poner los cables de la columna montante cerca de los cables de alimentación (230/400V).
- No introducir objetos ni echar líquidos en el interior del dispositivo.
- La instalación, el montaje y el mantenimiento de los aparatos eléctricos deben ser efectuados exclusivamente por electricistas especializados.
- Antes de efectuar cualquier operación de mantenimiento hay que cortar la alimentación.
- Conectar el bastidor de soporte de los módulos a tierra (véase Fig.).
- No mantener presionado el gancho de audio si el micro teléfono está descolgado.
- No instalar la telecámara delante de grandes fuentes luminosas ni en lugares donde la persona captada quede en contraluz. Para evitar este problema, se aconseja instalar la telecámara a una altura de 180 cm (en lugar de la altura habitual de 160-165 cm) y orientar el objetivo hacia abajo ya que esto mejora la calidad de la toma.
- En condiciones de poca luminosidad, las telecámaras con sensor CCD en color ofrecen una menor sensibilidad que las telecámaras en blanco y negro. Por lo tanto, en ambientes poco iluminados, se aconseja instalar una fuente luminosa adicional.

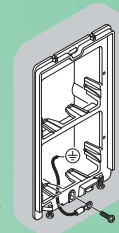

Generalidades	88
Unidad externa	88
Art. 4879KC	88
Art. 1207	88
Instalación de la unidad externa	88
Montaje de los tarjeteros	89
Unidades internas	90
Montaje de la unidad interna Magis	90
Desenganche del monitor	90
Art. 6402E	91
Descripción del monitor	91
Art. 2608	92
Instalación del telefonillo Art. 2608	92
Indicaciones generales de instalación y funcionamiento	93
Tabla de las distancias de funcionamiento	93
Funcionamiento	93
Descripción de las configuraciones y del funcionamiento de los pulsadores	94
Configuración del monitor Art. 6402E y telefonillo Style	94
TAB. A Direcciones de la columna montante	94
Descripción de las funciones de los pulsadores	94
Monitores adicionales, principales o secundarios	95
Uso del kit en instalaciones con puerta principal	95
Programación de los pulsadores Art. 4680KC	96
Configuración predefinida de los pulsadores	96
Advertencias generales para la programación de los pulsadores	96
Programación de los pulsadores para actuador genérico o asignado a una dirección	97
Programación para llamada intercomunicante	97
Programación/borrado de la dirección intercomunicante (solo para intercomunicante selectivo)	97
TAB. B Direcciones intercomunicante selectivo	97
Programación de los pulsadores para llamada intercomunicante	98
Programación de los pulsadores para otras funciones	98
TAB.C Direcciones de la columna montante	99
Reset de la programación	99
Programación range/tonos de llamada	100
Programación de la entrada IN1 para señalización de led/alarma/abrepuertas/actuador	101
Programación directa de la llamada intercomunicante	102
Variación de los tonos de llamada del monitor	102
Programaciones especiales Art. 4680KC	103
Esquema de conexión	
MSK/018IC Esquema básico para kits bifamiliares Art. 8172IMC con conexión en cascada. Puesta en funcionamiento/comprobación de las tensiones con la instalación en reposo	121
MSK/013IBC Esquema básico para kit bifamiliares Art. 8172IMC con conexión en derivación	122
MSK/014IBC Esquema para kits bifamiliares Art. 8172IMC ampliados con un segundo Art. 4879KC. Conexión en derivación	123
MSK/014IAC Esquema para kits bifamiliares Art. 8172IMC ampliados con un segundo Art. 4879KC. Conexión en cascada	124
MSK/018I/AC Esquema para kits bifamiliares con alimentador adicional Art. 1595	125
MSK/019IC Uso del módulo telecámara separada Art. 1259C	126
PXK/EC Conexión del relé actuador Art. 1256	127
MSK/EN/109IC Esquema para conectar a la puerta principal de dos a nueve Magis Kit mediante el Art. 4834/9	128
MSK/EN/110IC Esquema para conectar a la puerta principal treinta Magis Kit (máximo). Conexión Magis en cascada con Art. 1424	130
SB2/AAR Adición de un monitor principal en paralelo. Conexión en cascada	132
MSK/HCA Conexión del amplificador vídeo Art. 4833C	132
MSK/IC Adición de un monitor principal en paralelo. Conexión en derivación	133
MSK/A20S Conexión en cascada del tercer monitor principal con alimentación local	133
MSK/A23S Conexión en derivación de 2 monitores principales y 2 monitores secundarias con el mismo código de usuario	134

MSK/A21S Conexión en cascada de 2 monitores principales y 1 monitor secundario con el mismo código de usuario	134
MSK/AAE Conexión de telefonillos adicionales en derivación desde el monitor	135
MSK/AAD Conexión de telefonillos adicionales en cascada desde el monitor	135
MSK/FC Conexión de telefonillos adicionales en cascada desde el monitor	136
SB/X3 Pulsador P1 para varios usos (Art. 2608)	136
SB2V/AAK Conexión de dispositivos de repetición de llamada (Art. 1229 o Art. 1122/A)	137
Variante con conexión para llamada timbre de planta	137
Uso de la entrada IN1 como contacto para señalización de LED/ALARMA/ABREPUERTAS/ACTUADOR. Se activa al cerrar el contacto con CFP2 ...	138
Uso de la entrada IN1 como contacto para señalización de LED/ALARMA/ABREPUERTAS/ACTUADOR. Se activa cuando hay tensión con relación a IN2.	138
SB2/AAM2 Pulsador P1 para varios usos	139
PXK/RTNP Uso del relé de la unidad externa en el abrepuertas o mando actuador (véase Programaciones especiales en la pág 103: Gestión del mando actuador)	139
Uso de la red RC para el filtro de la cerradura en los contactos del relé	140
PXK/SNP Variante con cerradura de seguridad y alimentación adicional	140
PXK/DO Variante para el uso de la señalización de puerta abierta	141

Generalidades

Los kits de vídeo porteros bifamiliares Art. 8172IMC se pueden utilizar en edificios civiles o terciarios en los cuales se requiere un control eficaz del acceso y una fácil instalación.

En efecto, sólo se requieren dos conductores entre la unidad externa y los monitores internos para activar el sistema (llamada, audio, vídeo y autoencendido) más dos hilos para alimentar la unidad externa y la electrocerradura y otros dos para la unidad interna de vídeo portero.

Se encuentra disponible una amplia gama de accesorios para resolver fácilmente cualquier exigencia de instalación: además de interesantes accesorios estándar, es posible ampliar la instalación añadiendo monitores, telefonillos o unidades externas. De esta manera, es posible obtener 2 unidades externas con 8 unidades internas entre telefonillos y monitores de vídeo portero para la configuración bifamiliar.

Mediante las oportunas configuraciones, utilizando monitores de vídeo portero o telefonillos, es posible obtener comunicaciones intercomunicantes unifamiliares (entre usuarios con el mismo código de usuario).

También es posible conectar varios kits a una puerta principal Simplebus y/o a una centralita Art. 1998A.

Unidad externa

Art. 4879KC

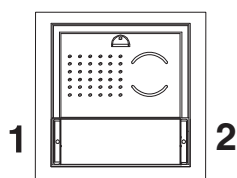

Art. 4879KC

Características técnicas

Conexión al monitor con dos hilos para audio, vídeo, abrepuertas y llamada más dos hilos para la alimentación desde el Art. 1207.

Telecámara orientable de alta sensibilidad con sensor CCD 1/3".

Tarjeteros con iluminación con led, seleccionable entre azul, blanca y apagada.

Regulación del volumen del altavoz.

Dimensiones de la caja de empotrar: 118x118x45 mm.

Los pulsadores del Art. 4879KC se han programado en fábrica para llamar a la dirección 1 (pulsador izquierdo) y 2 (pulsador derecho).

Dimensiones de la unidad externa: 112x89,5x40 mm.

Descripción de la regleta de conexiones

LL conexión al monitor (vídeo, llamada, audio y abrepuertas).

V+ V- entrada de la unidad externa.

RTE entradas abrepuertas local temporizado.

DO entrada de señalización de puerta abierta.

PR borne de programación.

GND borne negativo que se debe utilizar durante la fase de programación.

NO NC COM contactos del relé de 10 A.

SE conexión a la electrocerradura.

Art. 1207

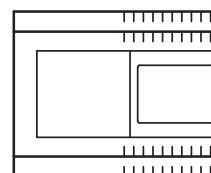

Características técnicas

El transformador prevé dos salidas: una para alimentar la unidad externa y la electrocerradura y otra para alimentar el monitor.

Dimensiones: 105x85x85 mm (6 módulos DIN).

Protección contra cortocircuitos y sobrecargas.

Descripción de la regleta de conexiones

L $\frac{1}{2}$ N entrada de tensión de red de 110-240 Vca.

+22V 0V salida de CC para la alimentación del monitor.

+33V 0V salida de CC para la unidad externa y la electrocerradura.

Instalación de la unidad externa

► Dejar colocada la protección de la instalación.

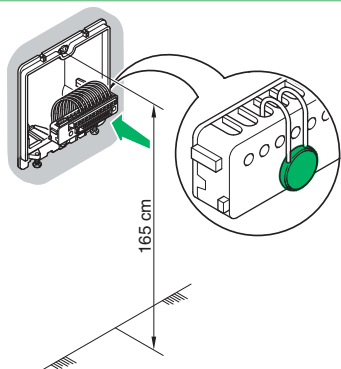

1

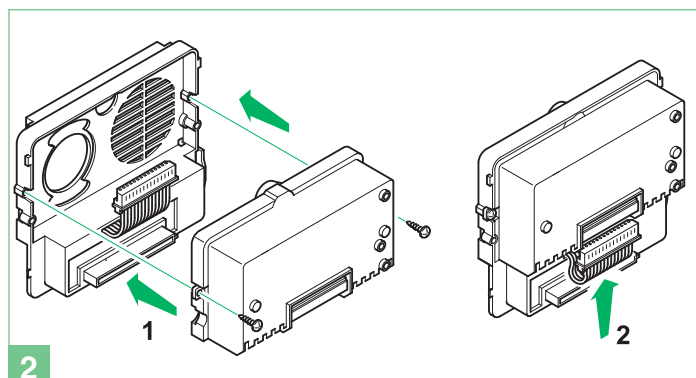

2

► Selección de la iluminación de los leds de los tarjeteros.

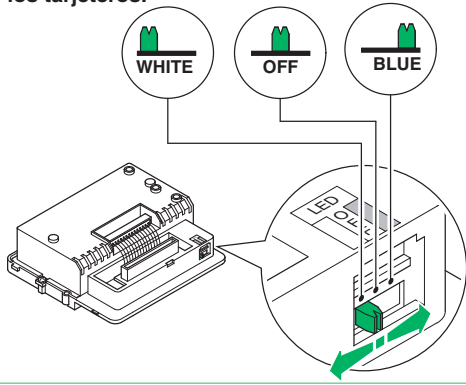

3

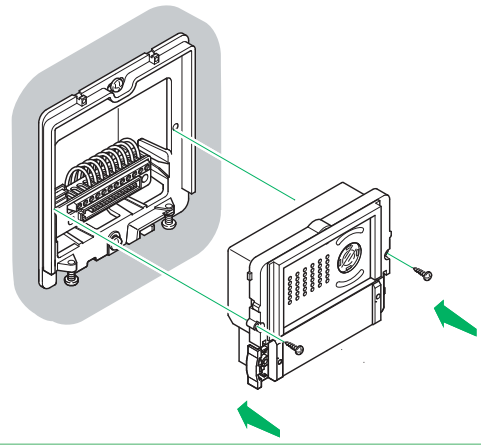

4

Posición alternativa del micrófono

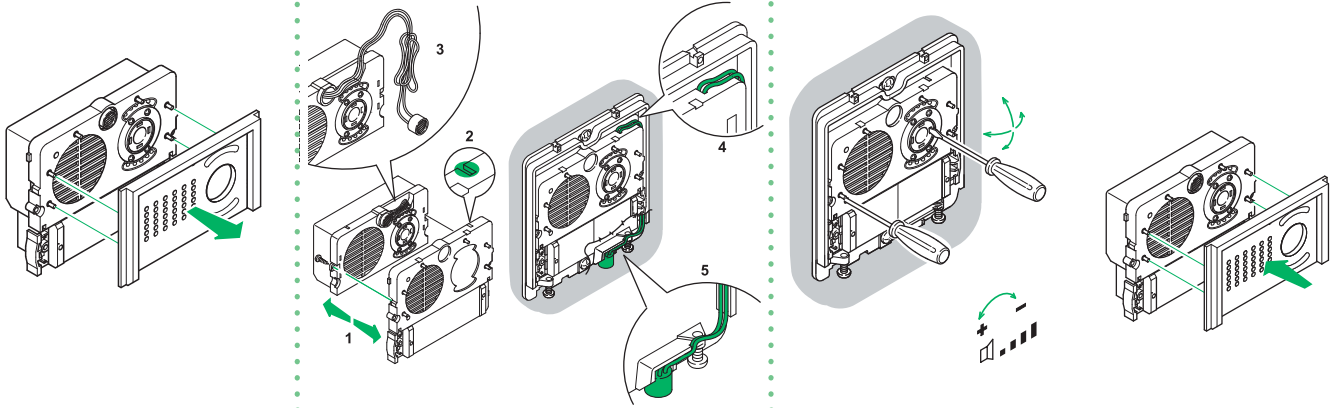

4A

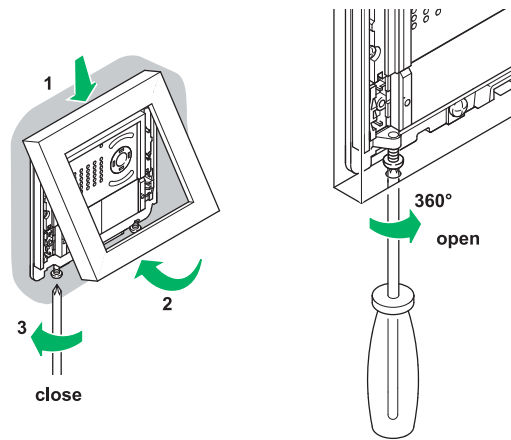

5

Montaje de los tarjeteros

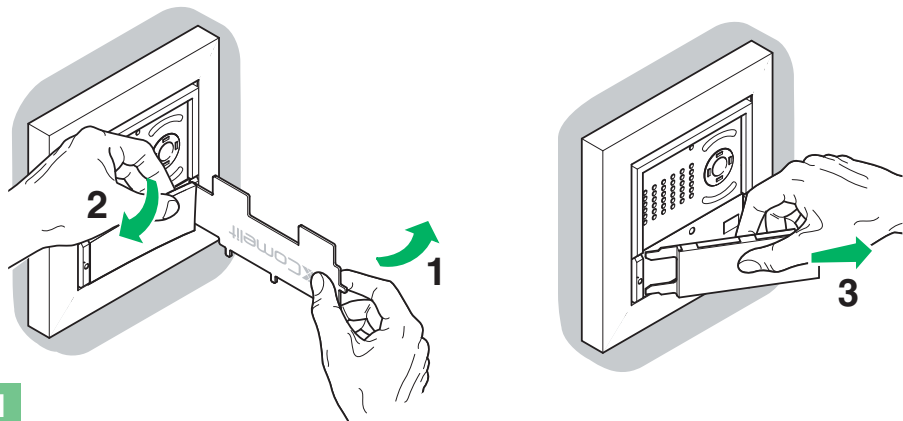

1

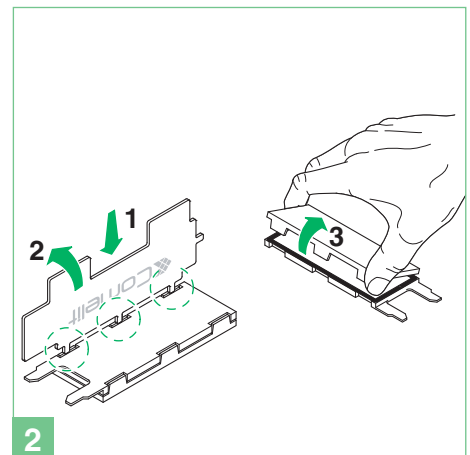

2

► Centrar el tarjetero para evitar filtraciones.

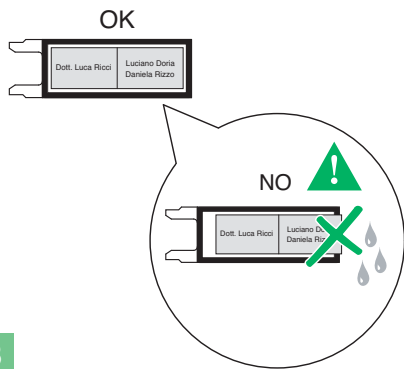

3

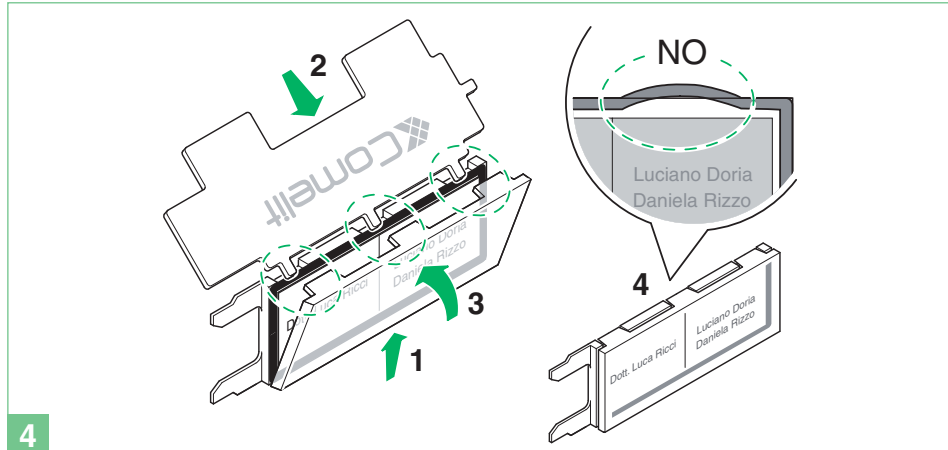

4

Unidades internas

Montaje de la unidad interna Magis

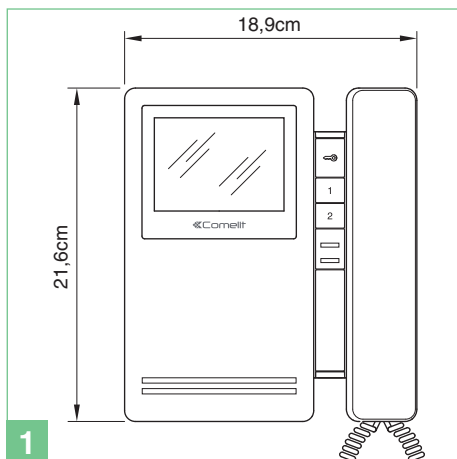

1

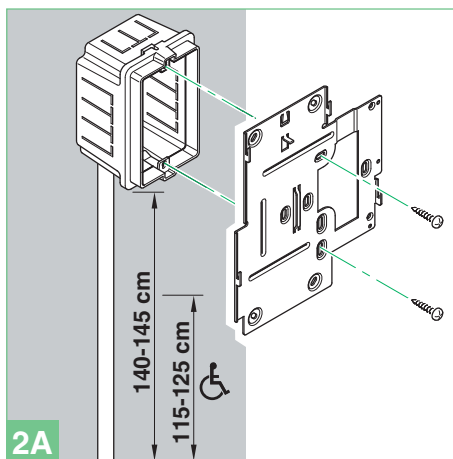

2A

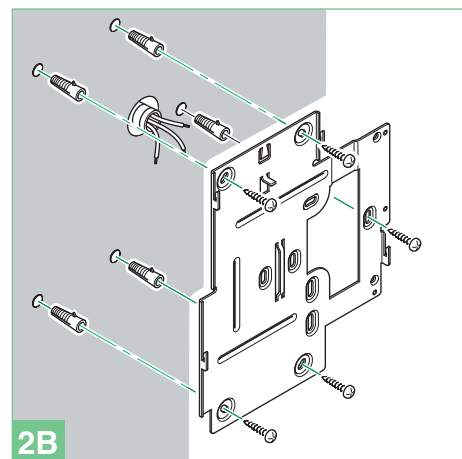

2B

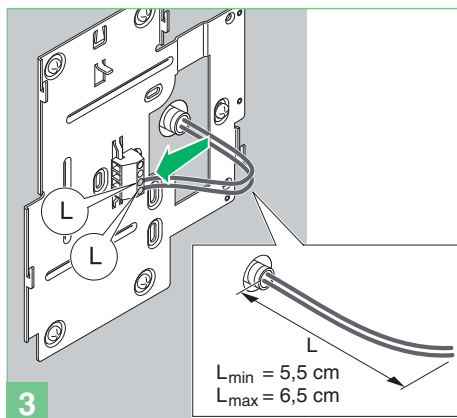

3

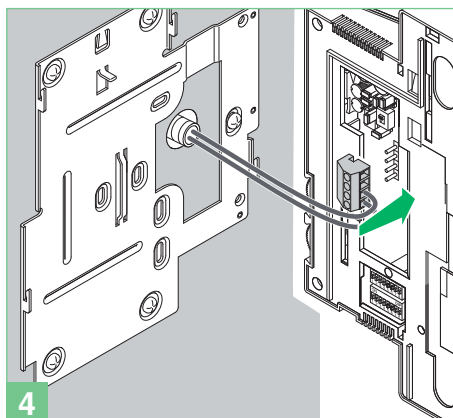

4

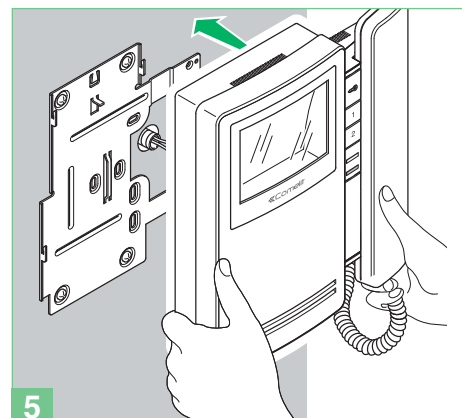

5

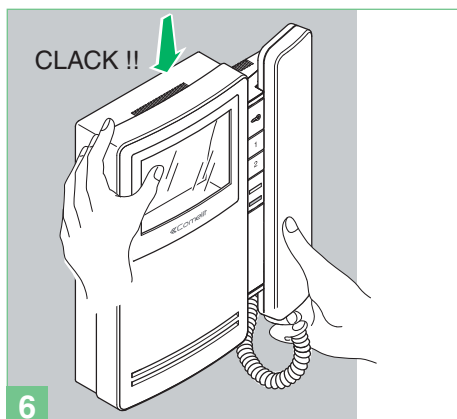

6

Desenganche del monitor

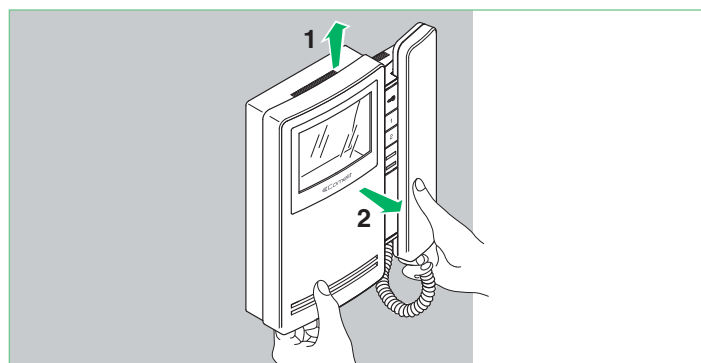

ES

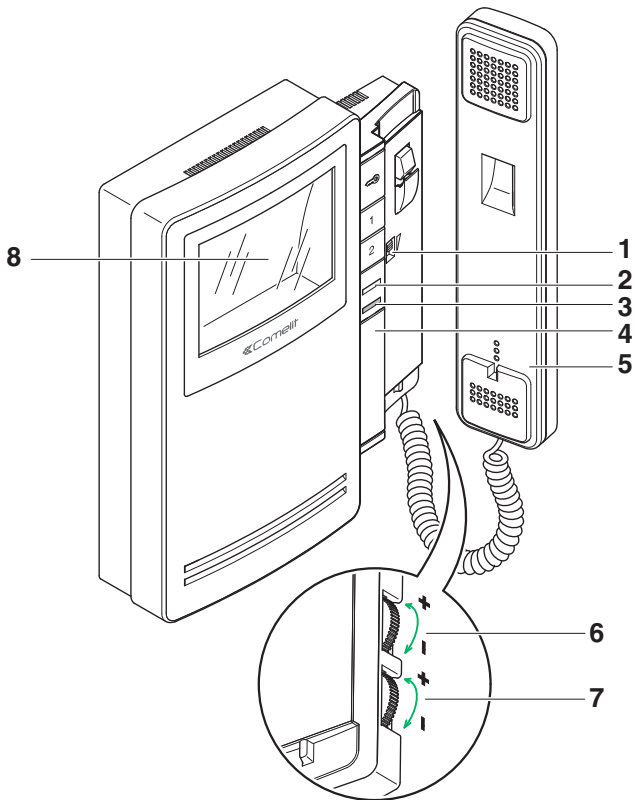

Descripción del monitor:

- 1 Regulación del volumen de llamada / selector de la función Privacidad (por función Privacidad se entiende la exclusión de la llamada desde la unidad externa y desde telefonillos o monitores de vídeo portero intercomunicantes; la activación de la función Privacidad está indicada por el encendido de un indicador rojo al lado del selector).
- 2 Led de señalización de instalación ocupada/función doctor activada/ puerta abierta.
- 3 Indicador rojo - Función privacidad activada.
- 4 Espacio para alojar los pulsadores adicionales con el accesorio Art. 6333, Art. 6434.
- 5 Micro teléfono del monitor (descolgarlo para empezar la comunicación)
- 6 Manípulo de regulación da intensidad da cor.
- ▶ Girar el mando hacia la izquierda para aumentar el valor.
- 7 Mando de regulación del brillo.
- ▶ Girar el mando hacia la izquierda para aumentar el valor.
- 8 Pantalla en color de 3,5".

Descripción de los pulsadores:

- ☞ Pulsador abrepuertas.
- 1 Tecla 1 de un actuador genérico (programable).
- 2 Tecla 2 de autoencendido (programable).

Descripción del monitor

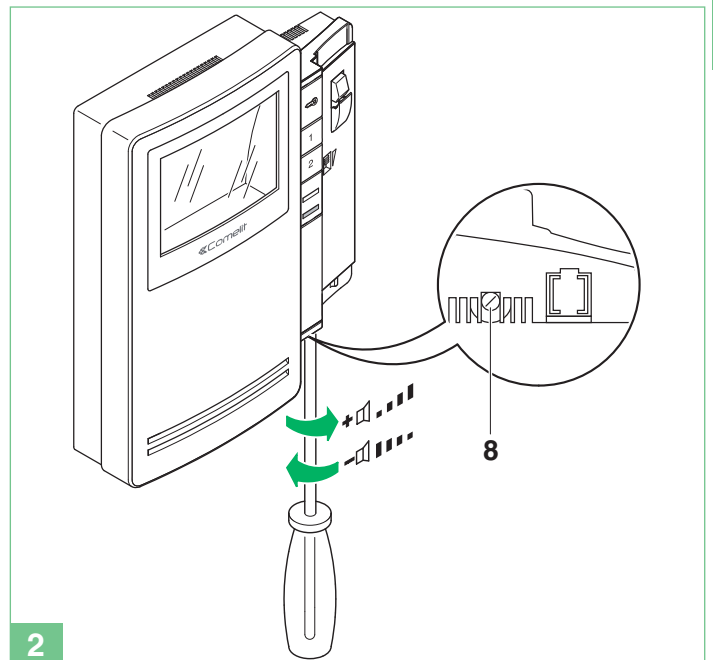
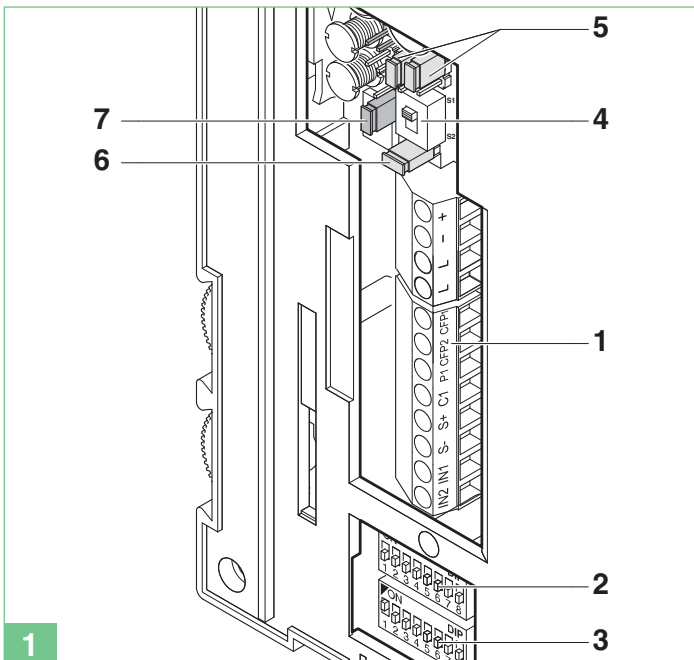

- 1 Regleta de conexiones para la instalación:
 + - Bornes para alimentación.
 L L Bornes de conexión a la línea Bus.
 CFP1 CFP2 Entrada para llamada timbre de planta.
 P1 C1 Bornes pulsador 1 para diferentes servicios.
Para obtener un contacto normalmente abierto (24 V - 100 mA máx.) poner los puentes CV3 y CV4 en posición B.
 S+ S- Bornes para el dispositivo de repetición de llamada.
 IN1 IN2 Entrada LED (programable).
- 2 S1 Microinterruptores para programar el código de usuario.
- 3 S2 Microinterruptores para programar los pulsadores y las funciones (identificado por un triángulo rojo en un ángulo):
 DIP 1-2-3-4 para programar las funciones de los pulsadores.
 DIP 5-6 para acceder a la programación.

- 2 DIP 7 para controlar la tensión de alimentación (véanse los esquemas y las variantes de la pág. 121), predefinido = **OFF**.
- DIP 8:
 ON soporte secundario.
 OFF soporte principal (predefinido).
- 4 SW3 Selector para modalidad Simplebus 1 (S1-predefinido) o Simplebus 2 (S2).
- 5 CV3 CV4 Punte para dejar libre el pulsador 1 (contacto NA 24 V-100 mA máx.).
 A Pulsador 1 de un actuador genérico (predefinido) o programable.
 B pulsador 1 para diferentes usos.
- 6 CV5 Punte para el cierre del vídeo.
- 7 CV6 Selector para uso de la entrada IN 1 (véase pág. 138).
- 8 Regulación del volumen del altavoz (solo para la configuración del audio intercomunicante).

Art. 2608

No se puede utilizar para aprovechar la función intercomunicante. El telefonillo siempre se tiene que montar utilizando el Art. 1214/2C como se ilustra en el esquema de conexión MSK/FC en la pág. 136.

- 1 Indicador de la función Privacidad.
- 2 Selector del tono de llamada/función Privacidad de tres posiciones: Posición superior: volumen máximo del tono de llamada. Posición central: volumen medio del tono de llamada. Posición inferior: activación de la función Privacidad. (Por función Privacidad se entiende la exclusión de la llamada desde la unidad externa y la centralita; la activación de la función Privacidad está señalada por el encendido de un indicador rojo en la parte superior derecha).
- 3 Trimmer de regulación del volumen del micrófono.
- 4 Microinterruptores para programar el código de usuario.
- 5 Bornes de conexión de la instalación:
 L L Conexión a la línea Bus.
 CFP CFP Entrada para llamada timbre de planta.
 P1 C1 Bornes pulsador P1 para diferentes servicios (contacto normalmente abierto 24 V-100 mA máx.) (quitar CV1 y CV2, véase variante SB/X3 pág. 136).
 S+ S- Bornes para dispositivo de repetición de llamada.
- 6 CV1 CV2 Puentes que se han de quitar para obtener un contacto libre de potencial normalmente abierto en el pulsador P1.
- 7A/7B JP1 Puente para seleccionar las funciones Llamada a la centralita (posición C) y actuador genérico (posición A) del pulsador P1.

Descripción de los pulsadores:

- ☐ Pulsador abrepuertas.
- P1 Pulsador P1 de llamada a la centralita / actuador genérico / pulsador para diferentes funciones presente en la regleta de conexiones (P1 C1).

Limpiar con un paño humedecido en agua. Evitar alcohol y otros productos agresivos.

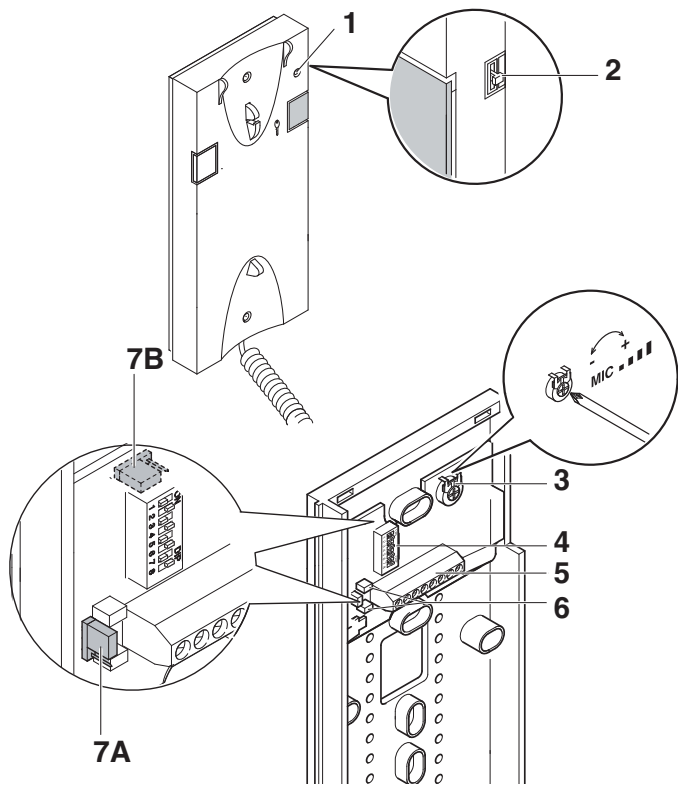

Instalación del telefonillo Art. 2608

ES

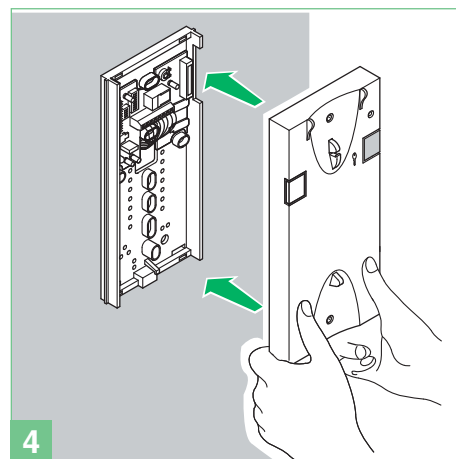
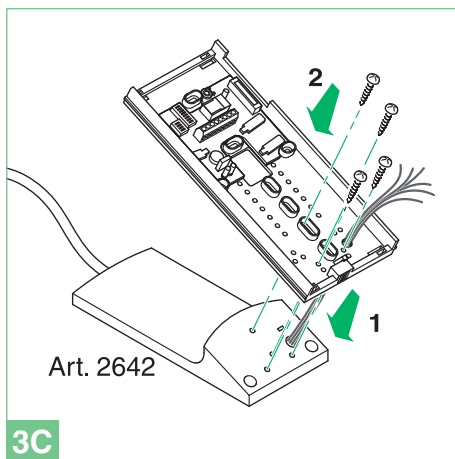
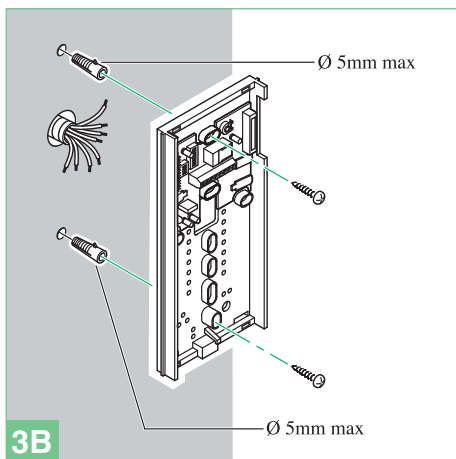
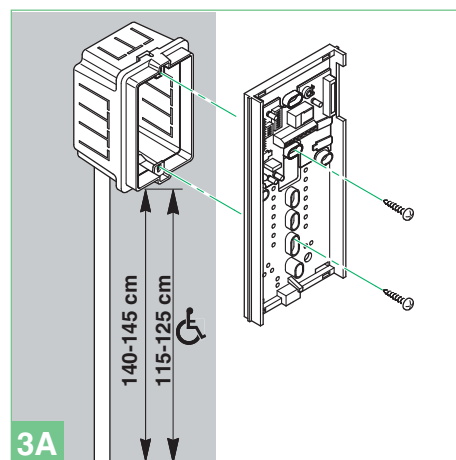
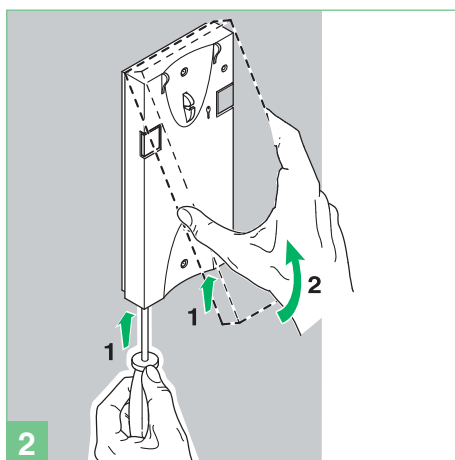
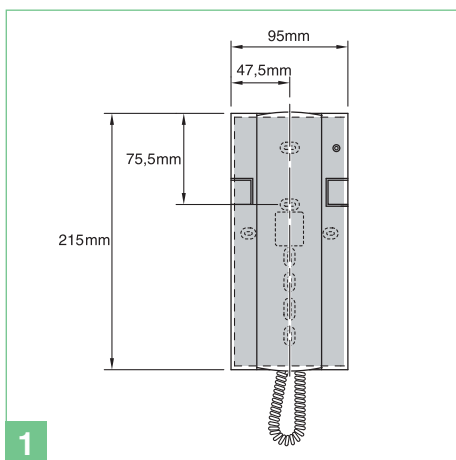



















Indicaciones generales de instalación y funcionamiento

La distancia máxima que puede haber entre la unidad externa y el monitor más lejano es de 400 m (con amplificador Art. 4833C).
Las unidades internas con el mismo código de usuario y los dispositivos de repetición de llamada conectados a dichas unidades internas no pueden sumar más de 4.

Conectar un único dispositivo de repetición de llamada para cada unidad interna.

Entre la unidad interna y el dispositivo de repetición de la llamada puede haber 20 m como máximo. Utilizar cable blindado para la conexión y no tender los cables cerca de cargas inductivas pesadas o cables de alimentación (230 V / 400 V).

Tabla de las distancias de funcionamiento

		A/G MAX	B/E MAX	C MAX	D MAX	F MAX	Art. 1216
Comelit Art. 4577 1 mm ² (Ø 1,2 mm AWG 17) 		50 m (165 feet)	50 m (165 feet)	200 m (655 feet)	100 m (330 feet)	150 m (495 feet)	
Comelit Art. 4576-4578	0,5 mm ² (Ø 0,8 mm AWG 20) bus 		25 m (85 feet)	200 m (655 feet)	100 m (330 feet)	150 m (495 feet)	
	1,5 mm ² (Ø 1,4 mm AWG 15) power 	75 m (245 feet)	100 m (330 feet)				
UTP5 cat. 5 0,2 mm ² (Ø 0,5 mm AWG 24) 				190 m (625feet)	60 m (195 feet)	150 m (495 feet)	
0,28 mm ² (Ø 0,6 mm AWG 23) 		5 m (15 feet)		190 m (625 feet)	60 m (195 feet)	150 m (495 feet)	
0,5 mm ² (Ø 0,8 mm AWG 20) 		25 m (85 feet)	25 m (85 feet)	190 m (625 feet)	60 m (195 feet)	150 m (495 feet)	
1 mm ² (Ø 1,2 mm AWG 17) 		50 m (165 feet)	50 m (165 feet)	190 m (625 feet)	60 m (195 feet)	150 m (495 feet)	
1 mm ² (Ø 1,2 mm AWG 17) 		50 m (165 feet)	50 m (165 feet)	120 m (395 feet)	40 m (130 feet)	100 m (330 feet)	
1,5 mm ² (Ø 1,4 mm AWG 15) 		75 m (245 feet)	100 m (330 feet)	190 m (625 feet)	60 m (195 feet)	150 m (495 feet)	
2,5 mm ² (Ø 1,8 mm AWG 13) 		100 m (330 feet)	150 m (495 feet)	190 m (625 feet)	60 m (195 feet)	150 m (495 feet)	

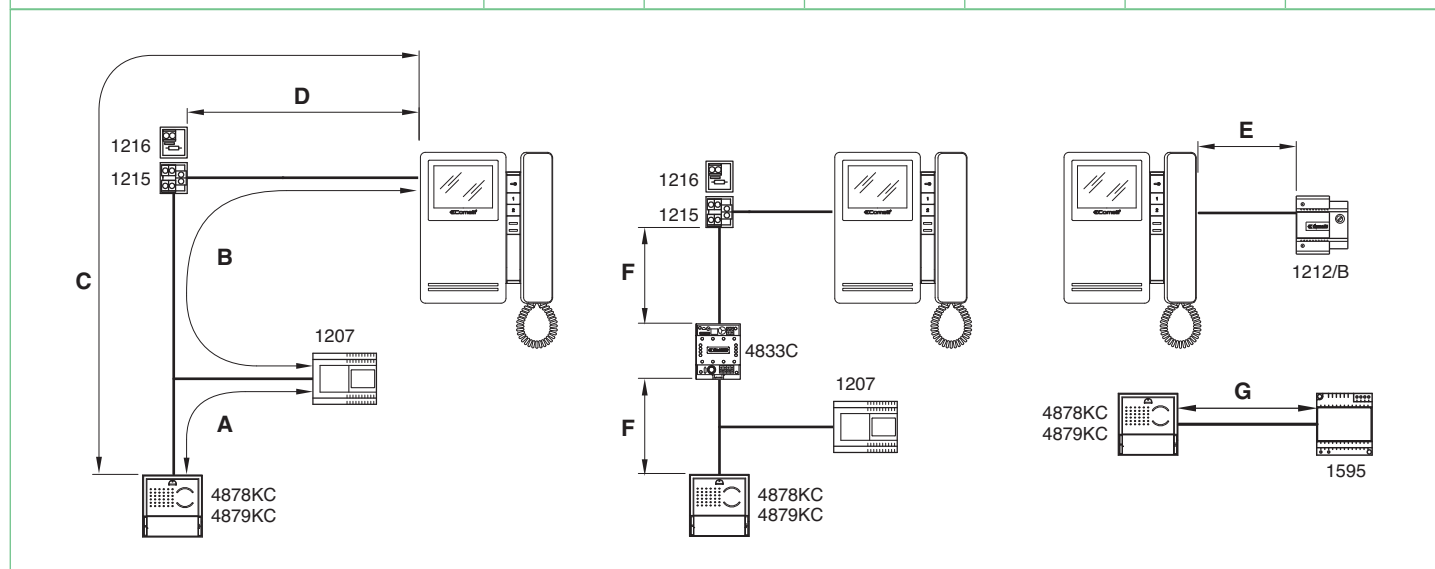

Funcionamiento

 **En caso de que se produzca un cortocircuito persistente en la línea de bus, en la unidad externa se oye un tono de señalización intermitente.**

El visitante, al pulsar la tecla de llamada, provoca el encendido de los leds de infrarrojos que lo iluminan, el toque del timbre interno (si la función Privacidad no está activada) y la visualización de su imagen en los monitores principales durante 60 segundos.

La conversación entre la unidad externa y la unidad interna puede durar 90" como máximo.

En la unidad externa se obtiene un tono de confirmación de que se ha efectuado la llamada; si, en instalaciones con dos o más entradas, al efectuar una llamada, la unidad externa emite un tono de ocupado en lugar de repetir el timbre, significa que ya existe una comunicación con otra unidad externa.

Para programar direcciones de usuarios diferentes a las programadas en fábrica (1 y 2), véase la pág. 94.

Para las funciones intercomunicantes del sistema Magis Kit, véase página 97.

Descripción de las configuraciones y del funcionamiento de los pulsadores

Configuración del monitor Art. 6402E y telefonillo Style

Posición de los microinterruptores del monitor Art. 6402E

► En los telefonillos Art. 2608, Art. 2610 y Art. 2628, colocar los DIP switch **S1-6**, **S1-7** y **S1-8** en **OFF**

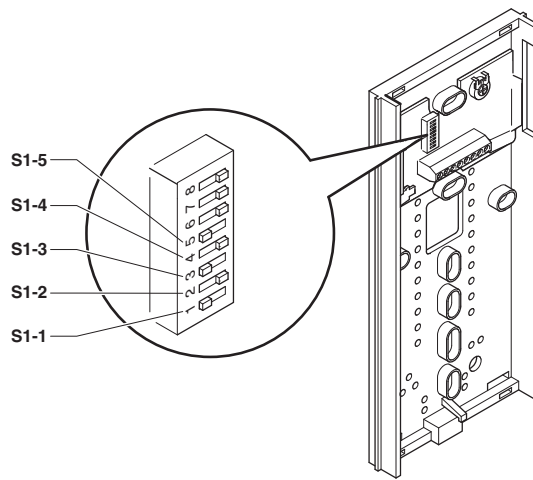
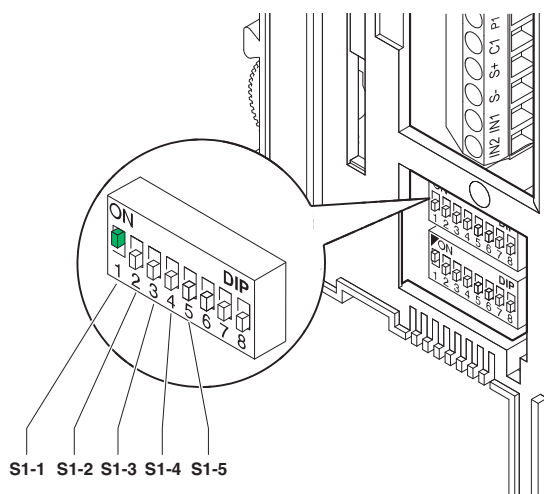

Los valores de los microinterruptores **S1-1**, **S1-2**, **S1-3**, **S1-4** y **S1-5** definen la **dirección de la llamada** del monitor y de los telefonillos como se indica en la tabla siguiente.

TAB. A Direcciones de la columna montante

Código	S1	Código	S1	Código	S1	Código	S1
1		9		17		25	
2		10		18		26	
3		11		19		27	
4		12		20		28	
5		13		21		29	
6		14		22		30	
7		15		23			
8		16		24			

Descripción de las funciones de los pulsadores

La llamada intercomunicante bifamiliar (entre teléfonos y/o monitores) sólo es posible si se han configurado los dos usuarios con códigos de llamada contiguos (indicados con la misma letra AA..CC..OO en la tabla de programación de los microinterruptores, ilustrada en la página 94).

🔑 **Abrepuertas:** Al presionar el pulsador abrepuertas, se activa la cerradura conectada a la unidad externa.

Actuador: Si el pulsador se ha configurado como actuador, al presionarlo se activa el relé actuador Art. 1256 que se puede utilizar, por ejemplo, para abrir cancelas o puertas basculantes o para encender el módulo telecámaras cíclicas Art. 1259/C.

Pulsador libre: la indicación de pulsador libre indica la posibilidad de utilizar el pulsador como contacto normalmente abierto en la regleta de conexiones mediante las correspondientes configuraciones como se ilustra en la variante SB2/AAM2 en la página 139.

Autoencendido / solicitud de vídeo

Es posible inhabilitar el autoencendido.

El autoencendido sólo es posible cuando la instalación está en reposo.

El autoencendido sólo se aconseja para instalaciones con una o dos entradas.

Si se presiona la tecla 2, configurada en esta modalidad, en el monitor se visualiza la imagen transmitida desde la unidad externa, incluso si no se ha efectuado ninguna llamada.

En instalaciones dotadas con dos unidades externas es posible visualizar alternativamente la imagen procedente de una u otra unidad externa (función "báscula") presionando repetidamente la tecla 2.

En los monitores secundarios (DIP switch 8 de S2 en ON) esta tecla 2 también sirve para la función Solicitud de vídeo, es decir, permite encender un monitor tras una llamada desde la unidad externa.

Habilitación:

► presionar el pulsador de autoencendido del monitor durante más de 4 s.
» tono de confirmación.

Inhabilitación:

► presionar el pulsador de autoencendido del monitor durante más de 4 s.
» 4 tonos de confirmación.

Encendido:

► presionar y soltar de inmediato el pulsador dedicado (pulsador 2 si se mantienen las configuraciones de fábrica).

Llamada a la centralita

Al accionar la tecla configurada en esta modalidad, se envía una llamada a la centralita de consejería de la instalación.

Llamada intercomunicante unifamiliar

Esta función permite enviar una llamada a otros aparatos (monitores de vídeo portero y/o telefonillos) configurados con el mismo código de llamada.

► Al descolgar el micro teléfono, el receptor de la llamada entra en comunicación con el usuario que llama. La comunicación termina al colgar el micro teléfono.

Una llamada intercomunicante no tiene prioridad sobre una conversación o llamada de una unidad externa.

En este caso, durante un intento de llamada intercomunicante, el led parpadea durante algunos segundos para indicar que el sistema está ocupado.

Llamadas desde la unidad externa

En cualquier caso, una llamada desde una unidad externa siempre tiene prioridad con relación a una comunicación intercomunicante

(La activación de la comunicación con la unidad externa interrumpe la conversación intercomunicante que se estaba llevando a cabo). Los usuarios que se encuentran en conversación sentirán en el auricular un tono parecido al de Llamada si esta última está dirigida a ellos o un triple tono de señalización en caso contrario.

► Para responder a la llamada de la unidad externa, sólo hay que descolgar el micro teléfono de alguna unidad libre o colgar y levantar el micro teléfono de una unidad ocupada en una intercomunicación.

Doctor

Esta función permite accionar automáticamente el abrepuertas tras una llamada desde la unidad externa en la dirección de la unidad interna en la que se ha activado la función.

Habilitación / inhabilitación:

► mantener presionado durante 2 s el pulsador que se ha configurado para esta función.

»Con la función activada, el led de señalización permanece encendido.

Monitores adicionales, principales o secundarios

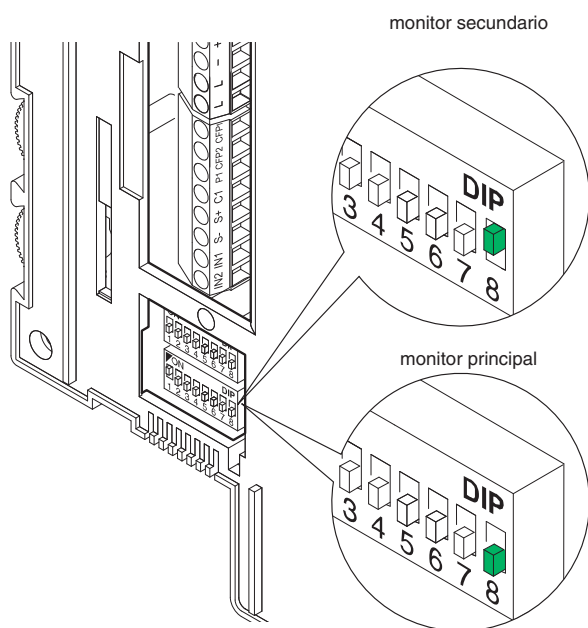

La configuración del DIP switch 8 de S2 define si la placa soporte en cuestión se gestionará como principal (P) o como secundaria (S).

La unidad externa puede gestionar hasta un máximo de cuatro monitores de vídeo portero o telefonillos por pulsador de llamada.

Por lo tanto, en la configuración clásica de Magis Kit, se puede disponer de 2 monitores de vídeo portero principales como máximo y de 2 monitores de vídeo portero secundario por pulsador de llamada, alimentados todos ellos por el mismo alimentador **Art. 1207**.

Existe la posibilidad de gestionar hasta 3 monitores de vídeo portero principales dentro de una misma unidad familiar (es decir, configurados con el mismo código de usuario). En esta configuración especial, los monitores de vídeo portero principales adicionales se han de alimentar con el correspondiente transformador **Art. 1212/B** (véase variante MSK/HCA, MSK/IC pág. 132, 133).

Cuando se efectúa una llamada desde la unidad externa, el monitor que se enciende es el monitor de vídeo portero principal.

Los otros monitores secundarios de la misma unidad familiar permanecen apagados. Respondiendo a la llamada de la unidad externa desde un monitor de vídeo portero secundario, la imagen se visualiza de inmediato. Luego, el monitor del vídeo portero principal se apaga y la imagen se visualiza en el monitor del vídeo portero secundario desde el cual se ha accionado el pulsador 2 Autoencendido / Solicitud de vídeo.

Para ver la imagen sin activar el audio con la unidad externa, hay que presionar el pulsador 2- Autoencendido / Solicitud de vídeo.

Uso del kit en instalaciones con puerta principal

En los esquemas MSK/EN/109IC y MSK/EN/110IC de las pág. 128 y 131 se ilustra un ejemplo de configuración de la instalación; dicha configuración ofrece la posibilidad de gestionar hasta un máximo de 30 Magis Kit por parte de un Art. 4680C - Art. 4680KC* instalado, por ejemplo, en la entrada de un complejo residencial.

Utilizando estos esquemas de instalación es posible llamar a uno de los Magis Kit desde la entrada principal dotada con el Art. 4680C - Art. 4680KC*. En esta configuración, es necesario programar los pulsadores del Art. 4680KC a bordo del Art. 4879KC como se describe en las operaciones

siguientes y las unidades externas con el código correspondiente (véase la tabla en la pág. 94).

Para mayor información sobre la integración de los Magis Kit en instalaciones Simplebus y para programar la puerta principal (Art. 4680C - Art. 4680KC*), véase el catálogo (n. 140) y la hoja técnica cod. 2G40000472.

* Límites de uso del Art. 4680KC

El Art. 4680KC gestiona las llamadas procedentes de los módulos de pulsadores o digitales **SÓLO** si están comprendidas entre la dirección 1 y la dirección 10.

Programación de los pulsadores Art. 4680KC

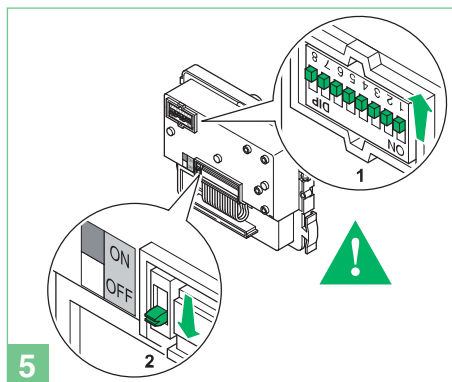
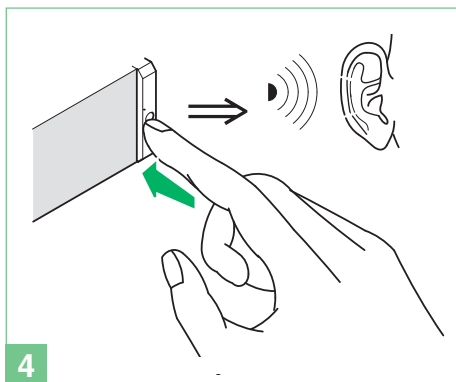
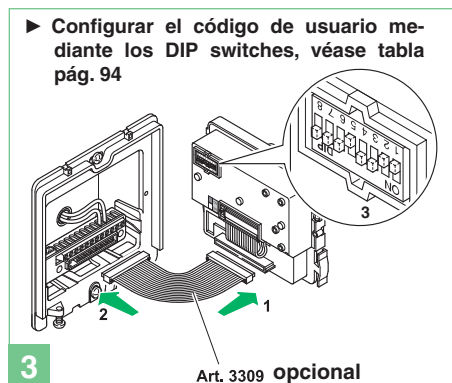
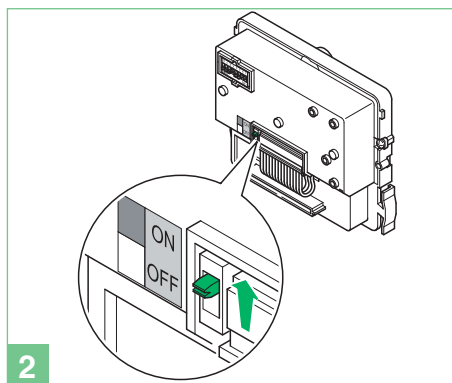
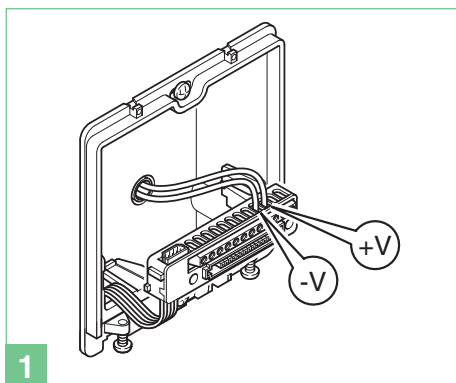

Configuración predefinida de los pulsadores

DIP S2				con Art. 6433, 6434							
DIP 1	DIP 2	DIP 3	DIP 4	P1	P2			P3	P4	P5	P6
0	0	0	0	CCS	AI	🔑	📞	ACT	D	PAN	K
1	0	0	0	ACT	AI	🔑	📞	INT	INTb	D	CCS
0	1	0	0	INT	AI			INTb	ACT	CCS	CCP
1	1	0	0	ACT	CCS			CCP	PAN	K	D
0	0	1	0	ACT	ACT	ACT		ACT	ACT	ACT	ACT
1	0	1	0	INT	ACT			CCS	CCP	INTb	PAN
0	1	1	0	AI	D			K	CCS	CCP	INTb
1	1	1	0	INTb	INT			AI	INT	PAN	D
0	0	0	1	CCS	PAN			D	AI	INT	INTb
1	0	0	1	K	CCS	🔑		PAN	CCP	AI	INT
0	1	0	1	CCP	K			PAN	ACT	INT	AI
1	1	0	1	PAN	CCP			CCS	K	ACT	D
0	0	1	1	D	INTb			INT	ACT	AI	CCS
1	0	1	1	INT	INT			INT	INT	INT	INT
0	1	1	1	NULL	NULL	NULL	NULL	NULL	NULL	NULL	NULL
1	1	1	1						PROG		

Leyenda

🔑	Abrepuertas	CCS	Llamada a la centralita	INTb	Intercomunicante bifamiliar - sólo para KIT
📞	Audio	K	Llamada al telefonillo del vigilante	NULL	Ninguna función
ACT	Actuador	D	Doctor	PROG	Funciones programadas, véanse págs. 96-97-98-99 Con esta configuración de DIP switches, los pulsadores controlan las funciones programadas; los pulsadores NO programados gestionan las funciones relativas a la línea 0000
AI	Autoencendido	PAN	Pánico		
CCP	Llamada a la centralita principal	INT	Intercomunicante programable general o selectivo - llamada bifamiliar de serie para KIT y Simplebus Top		

⚠ Advertencias generales para la programación de los pulsadores

Si la configuración predefinida de los pulsadores (véase tabla de pág. 96) no responde a las necesidades del usuario, es posible configurarlos de otra manera según se describe a continuación.
Al término, poner los DIP switches 1-2-3-4 de S2 en 1111 (configuración PROG en las tablas de las págs. 96-97-98-99). Configurando los DIP

switches de esta manera, los pulsadores gestionan las funciones programadas; los pulsadores NO programados gestionan las funciones relativas a la línea 0000 (véase tabla de pág. 96). Restablecer la configuración del código de usuario en S1, véase tabla A de pág. 94.

Programación de los pulsadores para actuador genérico o asignado a una dirección

DIP S2				con Art. 6433, 6434						DIP S1			
DIP 1	DIP 2	DIP 3	DIP 4	P1	P2			P3	P4	P5	P6	DIRECCIÓN 	
0	0	0	0					ACT					
1	0	0	0	ACT									
0	1	0	0						ACT				
1	1	0	0	ACT									
0	0	1	0	ACT	ACT	ACT		ACT	ACT	ACT	ACT		
1	0	1	0		ACT								
0	1	1	0										
1	1	1	0										
0	0	0	1										
1	0	0	1										
0	1	0	1						ACT				
1	1	0	1							ACT			
0	0	1	1										
1	0	1	1										
0	1	1	1										
1	1	1	1										
PROG													

Ejemplo:

En el monitor con código de usuario 5 se desea programar P1= actuador genérico y P2= actuador asignado a código 125.

1. Programar los DIP switches 5-6 de S2 en 01.

» *el led (verde) parpadea.*

2. Consultar la tabla de pág. 97 y elegir una combinación en la que aparezca la función actuador (ACT) para los pulsadores que se desea programar.

ES: para P1= actuador genérico, programar los DIP switches 1-2-3-4 de S2 en 1000, 1100 o 0010 (P1=ACT) y los DIP switches de S1 en 11111111. Pasar al punto 3.

ES: para P2= actuador asignado a código 125, programar los DIP switches 1-2-3-4 de S2 en 0010 o 1010 (P2=ACT) y S1 con la dirección 125 según se ilustra en la **tabla C** de pág. 99. Pasar al punto 3.

3. Presionar y soltar el pulsador al que se desea asociar la función.

» *el led (verde) se enciende.*

» *tono de confirmación en el micro teléfono.*

4. Para salir de la programación, programar los DIP switches 5-6 de S2 en 00.

» *el led (verde) se apaga.*

5. Terminada la programación, poner los DIP switches 1-2-3-4 de S2 en 1111. Restablecer la configuración del código de usuario en S1, véase tabla C de pág. 99.

Programación para llamada intercomunicante



Intercomunicante general y selectivo **NO** son compatibles en la misma columna montante.

Programación/borrado de la dirección intercomunicante (solo para intercomunicante selectivo)

S1	2)						S2	3)
	DIP 1	DIP 2	DIP 3	DIP 4	DIP 5	DIP 6		
Programación; programar código, TABLA B de pág. 97	0	0	0	1	1	1		
Borrado	1	1	1	1	1	1		



Anotar la posición de **S2**, **S1** y restablecerla una vez efectuada la programación.

TAB. B Direcciones intercomunicante selectivo

Código	Dip switch ON	S1	Código	Dip switch ON	S1	Código	Dip switch ON	S1
1	1		4	4		7	7	
2	2		5	5		8	8	
3	3		6	6				

Es necesario configurar la dirección intercomunicante en todas las unidades internas de la columna montante. Es posible asociar la misma dirección intercomunicante a un máximo de tres unidades internas. Para la llamada de grupo, seleccionar simultáneamente los códigos intercomunicantes deseados (máximo 3).

Programación de los pulsadores para llamada intercomunicante

DIP S2				con Art. 6433, 6434				DIP S1					
DIP 1	DIP 2	DIP 3	DIP 4	P1	P2			P3	P4	P5	P6	DIRECCIÓN 	
0	0	0	0										
1	0	0	0					INT	INTb				
0	1	0	0	INT				INTb					
1	1	0	0										
0	0	1	0										
1	0	1	0	INT						INTb			
0	1	1	0								INTb		
1	1	1	0	INTb	INT				INT				
0	0	0	1							INT	INTb		
1	0	0	1								INT		INT
0	1	0	1							INT			
1	1	0	1										
0	0	1	1		INTb			INT					
1	0	1	1	INT	INT			INT	INT	INT	INT		
0	1	1	1										
1	1	1	1										

Ejemplo 1 - Intercomunicante selectivo

En el monitor con código de usuario 1 y dirección intercomunicante 1 se desea programar P3= intercomunicante selectivo a la dirección 2 y P4= intercomunicante selectivo a la dirección 3.

Ejemplo 2 - Intercomunicante KIT (intercomunicante entre 2 direcciones contiguas en el intervalo 1 a 30 de las cuales la primera impar).

En el monitor con código de usuario 1 se desea programar P3= llamada general interna y P4= intercomunicante bifamiliar a la dirección 2.

1. Programar los DIP switches 5-6 de S2 en 01.

» *el led (verde) parpadea.*

2. Consultar la tabla de pág. 98 y elegir una combinación en la que aparezca la función intercomunicante (INT o INTb) para los pulsadores que se desea programar.

ES1: para P3= intercomunicante selectivo, programar los DIP switches 1-2-3-4 de S2 en 1000, 0011 o 1011 (P3=INT) y S1 con la dirección 2 según se ilustra en la **tabla B** de pág. 97, pasar al punto 3.

ES1: para P4= intercomunicante selectivo, programar los DIP switches 1-2-3-4 de S2 en 1110 o 1011 (P4=INT) y S1 con la dirección 3 según se ilustra en la **tabla B** de pág. 97, pasar al punto 3.

ES2: para P3= llamada general interna y P4= intercomunicante bifamiliar, programar los DIP switches 1-2-3-4 de S2 en 1000 (P3=INT y P4=INTb) y S1 con código de usuario 1 según se ilustra en la **tabla A** de pág. 94, pasar al punto 3.

3. Presionar y soltar el pulsador al que se desea asociar la función.

» *el led (verde) se enciende.*

» *tono de confirmación en el micro teléfono.*

4. Para salir de la programación, programar los DIP switches 5-6 de S2 en 00.

» *el led (verde) se apaga.*

5. Terminada la programación, poner los DIP switches 1-2-3-4 de S2 en 1111. Restablecer la configuración del código de usuario en S1, véase **tabla A** de pág. 94.

ES

Programación de los pulsadores para otras funciones

DIP S2				con Art. 6433, 6434				DIP S1					
DIP 1	DIP 2	DIP 3	DIP 4	P1	P2			P3	P4	P5	P6	PROG	
0	0	0	0	CCS	AI				D	PAN	K		
1	0	0	0		AI					D	CCS		
0	1	0	0		AI					CCS	CCP		
1	1	0	0		CCS			CCP	PAN	K	D		
0	0	1	0										
1	0	1	0										
0	1	1	0	AI	D			CCS	CCP		PAN		
1	1	1	0					AI	CCS	CCP	D		
0	0	0	1	CCS	PAN			D	AI				
1	0	0	1	K	CCS			PAN	CCP	AI			
0	1	0	1	CCP	K			PAN	CCP		AI		
1	1	0	1	PAN	CCP			CCS	K		D		
0	0	1	1	D						AI	CCS		
1	0	1	1										
0	1	1	1	NULL	NULL	NULL	NULL	NULL	NULL	NULL	NULL		NULL
1	1	1	1										

Leyenda

	Abrepuertas	CCS	Llamada a la centralita	NULL	Ninguna función
	Audio	K	Llamada al telefonillo del vigilante	PROG	Funciones programadas
AI	Autoencendido	D	Doctor		
CCP	Llamada a la centralita principal	PAN	Pánico		

Ejemplo:

En el monitor con código de usuario 5 se desea programar P5= autoencendido y P6= llamada a la centralita.

1. Programar los DIP switches 5-6 de S2 en 01.

» *el led (verde) parpadea.*

2. Consultar la tabla de pág. 98 y elegir una combinación en la que aparezcan las funciones deseadas/necesarias para los pulsadores que se desea programar.

ES: para P5= autoencendido y P6= llamada a la centralita, programar los DIP switches 1-2-3-4 de S2 en 0011 (P5=AI y P6=CCS).

3. Presionar y soltar el pulsador al que se desea asociar la función.

» *el led (verde) se enciende.*

» *tono de confirmación en el micro teléfono.*

4. Para salir de la programación, programar los DIP switches 5-6 de S2 en 00.

» *el led (verde) se apaga.*

5. Terminada la programación, poner los DIP switches 1-2-3-4 de S2 en 1111.

TAB.C Direcciones de la columna montante

Cod.	Dip switch ON	Cod.	Dip switch ON	Cod.	Dip switch ON	Cod.	Dip switch ON	Cod.	Dip switch ON	Cod.	Dip switch ON	Cod.	Dip switch ON	Cod.	Dip switch ON
1	1	31	1,2,3,4,5	61	1,3,4,5,6	91	1,2,4,5,7	121	1,4,5,6,7	151	1,2,3,5,8	181	1,3,5,6,8	211	1,2,5,7,8
2	2	32	6	62	2,3,4,5,6	92	3,4,5,7	122	2,4,5,6,7	152	4,5,8	182	2,3,5,6,8	212	3,5,7,8
3	1,2	33	1,6	63	1,2,3,4,5,6	93	1,3,4,5,7	123	1,2,4,5,6,7	153	1,4,5,8	183	1,2,3,5,6,8	213	1,3,5,7,8
4	3	34	2,6	64	7	94	2,3,4,5,7	124	3,4,5,6,7	154	2,4,5,8	184	4,5,6,8	214	2,3,5,7,8
5	1,3	35	1,2,6	65	1,7	95	1,2,3,4,5,7	125	1,3,4,5,6,7	155	1,2,4,5,8	185	1,4,5,6,8	215	1,2,3,5,7,8
6	2,3	36	3,6	66	2,7	96	6,7	126	2,3,4,5,6,7	156	3,4,5,8	186	2,4,5,6,8	216	4,5,7,8
7	1,2,3	37	1,3,6	67	1,2,7	97	1,6,7	127	1,2,3,4,5,6,7	157	1,3,4,5,8	187	1,2,4,5,6,8	217	1,4,5,7,8
8	4	38	2,3,6	68	3,7	98	2,6,7	128	8	158	2,3,4,5,8	188	3,4,5,6,8	218	2,4,5,7,8
9	1,4	39	1,2,3,6	69	1,3,7	99	1,2,6,7	129	1,8	159	1,2,3,4,5,8	189	1,3,4,5,6,8	219	1,2,4,5,7,8
10	2,4	40	4,6	70	2,3,7	100	3,6,7	130	2,8	160	6,8	190	2,3,4,5,6,8	220	3,4,5,7,8
11	1,2,4	41	1,4,6	71	1,2,3,7	101	1,3,6,7	131	1,2,8	161	1,6,8	191	1,2,3,4,5,6,8	221	1,3,4,5,7,8
12	3,4	42	2,4,6	72	4,7	102	2,3,6,7	132	3,8	162	2,6,8	192	7,8	222	2,3,4,5,7,8
13	1,3,4	43	1,2,4,6	73	1,4,7	103	1,2,3,6,7	133	1,3,8	163	1,2,6,8	193	1,7,8	223	1,2,3,4,5,7,8
14	2,3,4	44	3,4,6	74	2,4,7	104	4,6,7	134	2,3,8	164	3,6,8	194	2,7,8	224	6,7,8
15	1,2,3,4	45	1,3,4,6	75	1,2,4,7	105	1,4,6,7	135	1,2,3,8	165	1,3,6,8	195	1,2,7,8	225	1,6,7,8
16	5	46	2,3,4,6	76	3,4,7	106	2,4,6,7	136	4,8	166	2,3,6,8	196	3,7,8	226	2,6,7,8
17	1,5	47	1,2,3,4,6	77	1,3,4,7	107	1,2,4,6,7	137	1,4,8	167	1,2,3,6,8	197	1,3,7,8	227	1,2,6,7,8
18	2,5	48	5,6	78	2,3,4,7	108	3,4,6,7	138	2,4,8	168	4,6,8	198	2,3,7,8	228	3,6,7,8
19	1,2,5	49	1,5,6	79	1,2,3,4,7	109	1,3,4,6,7	139	1,2,4,8	169	1,4,6,8	199	1,2,3,7,8	229	1,3,6,7,8
20	3,5	50	2,5,6	80	5,7	110	2,3,4,6,7	140	3,4,8	170	2,4,6,8	200	4,7,8	230	2,3,6,7,8
21	1,3,5	51	1,2,5,6	81	1,5,7	111	1,2,3,4,6,7	141	1,3,4,8	171	1,2,4,6,8	201	1,4,7,8	231	1,2,3,6,7,8
22	2,3,5	52	3,5,6	82	2,5,7	112	5,6,7	142	2,3,4,8	172	3,4,6,8	202	2,4,7,8	232	4,6,7,8
23	1,2,3,5	53	1,3,5,6	83	1,2,5,7	113	1,5,6,7	143	1,2,3,4,8	173	1,3,4,6,8	203	1,2,4,7,8	233	1,4,6,7,8
24	4,5	54	2,3,5,6	84	3,5,7	114	2,5,6,7	144	5,8	174	2,3,4,6,8	204	3,4,7,8	234	2,4,6,7,8
25	1,4,5	55	1,2,3,5,6	85	1,3,5,7	115	1,2,5,6,7	145	1,5,8	175	1,2,3,4,6,8	205	1,3,4,7,8	235	1,2,4,6,7,8
26	2,4,5	56	4,5,6	86	2,3,5,7	116	3,5,6,7	146	2,5,8	176	5,6,8	206	2,3,4,7,8	236	3,4,6,7,8
27	1,2,4,5	57	1,4,5,6	87	1,2,3,5,7	117	1,3,5,6,7	147	1,2,5,8	177	1,5,6,8	207	1,2,3,4,7,8	237	1,3,4,6,7,8
28	3,4,5	58	2,4,5,6	88	4,5,7	118	2,3,5,6,7	148	3,5,8	178	2,5,6,8	208	5,7,8	238	2,3,4,6,7,8
29	1,3,4,5	59	1,2,4,5,6	89	1,4,5,7	119	1,2,3,5,6,7	149	1,3,5,8	179	1,2,5,6,8	209	1,5,7,8	239	1,2,3,4,6,7,8
30	2,3,4,5	60	3,4,5,6	90	2,4,5,7	120	4,5,6,7	150	2,3,5,8	180	3,5,6,8	210	2,5,7,8	*240	5,6,7,8

*NOTA: el código 240 está reservado a la centralita de conserjería

Reset del la programación

! 1)	! 2)						3)	4)
S1	DIP 1	DIP 2	DIP 3	DIP 4	DIP 5	DIP 6	S2	S1/S2/LED1
<p>DIP ON</p>	1	1	1	1	1	1	<p>5 sec</p>	<p>2 sec</p>
<p>Configuraciones de fábrica:</p> <ul style="list-style-type: none"> • Funciones de los pulsadores según la combinación de los DIP switches 1-2-3-4 de S2. • Dirección intercomunicante ausente. • Función intervalo y direcciones mín. y máx. ausentes. • Reset tonos de llamada. • Entrada IN 1 ⇒ LED (predefinido). 								<p> Anotar la posición de S2, S1 y restablecerla una vez efectuada la programación</p>

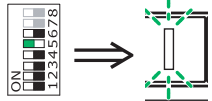
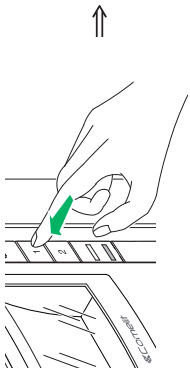
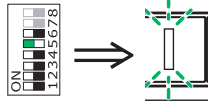
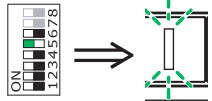
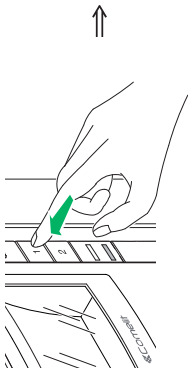
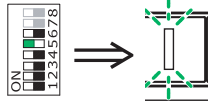
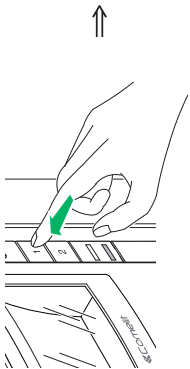
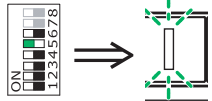
Efectuar las operaciones de 1 a 4										
1)		2)						3)		4)
S1		DIP 1	DIP 2	DIP 3	DIP 4	DIP 5	DIP 6	S2		
Programación range/tonos de llamada	Dirección mínima del intervalo	0	0	0	0	1	0			
	Dirección máxima del intervalo	0	0	0	0	0	0			
Habilitación del intervalo										
Inhabilitación del intervalo										
Selección del tono de llamada polifónico		0	1	0	1	1	0			
Selección del tono de llamada estándar (predefinido)										

 Anotar la posición de **S2**, **S1** y restablecerla una vez efectuada la programación

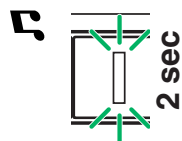

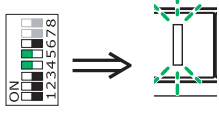
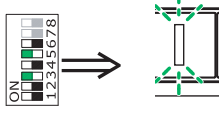
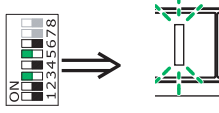
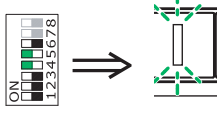
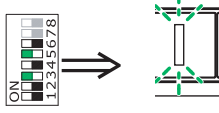
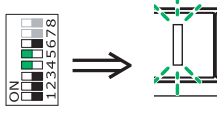
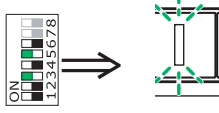
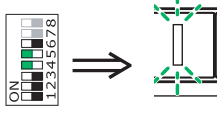
Efectuar las operaciones de 1 a 4									
1)		2)				3)		4)	
Programación de la entrada IN1 para señalización de led/alarma/abrepuertas/actuador	S1	DIP 1	DIP 2	DIP 3	DIP 4	DIP 5	DIP 6	S2	S1/S2/LED1
									
		0	0	0	1	1	0		
									
									
Entrada IN 1 ⇒ LED (predefinido), véase Pág. 138									
Entrada IN 1 ⇒ ALARMA, véase Pág. 138									
Entrada IN 1 ⇒ ABREPUERTAS, véase Pág. 138									
Entrada IN 1 ⇒ ACTUADOR ASIGNADO, véase Pág. 138									
Entrada IN 1 ⇒ ACTUADOR GENÉRICO, véase Pág. 138									

 Anotar la posición de S2, S1 y restablecerla una vez efectuada la programación

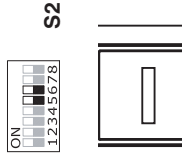
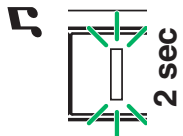

Programación directa de la llamada intercomunicante

Permite programar las llamadas intercomunicantes directamente desde las unidades internas.

✓ Necesita 2 operadores.

Fase 1: acceso a la programación

El operador 1 y el operador 2 han de efectuar las siguientes operaciones en 2 unidades internas:

1. Programar los DIP switches 1-2-3-4 de S2 en 1111.

2. Descolgar el auricular.

3. Presionar la tecla 1 y la 2 por 3 s.

» *La unidad interna emite 1 tono.*

» *El led verde parpadea.*

» *La unidad interna entra en comunicación audio.*

» *Entonces, los 2 operadores están en comunicación.*

Fase 2: programación de la llamada intercomunicante

Operador 1:

▶ Presionar el pulsador que se desea programar para llamar al operador 2 (por ejemplo, 2).

» *La unidad interna del operador 1 emite un tono de confirmación.*

Operador 2:

▶ Presionar el pulsador que se desea programar para llamar al operador 1 (por ejemplo, 1).

» *La unidad interna del operador 2 emite un tono de confirmación.*

Operador 1/Operador 2:

▶ Cuelgue el auricular.

» *La unidad interna emite 1 tono.*

» *La programación de las 2 unidades internas ha terminado.*

Para programar otra unidad interna, hay que pasar a la FASE 3.

Fase 3: programación de otras unidades internas

Operador 1/Operador 2:

1. Tras llegar a la nueva unidad, ejecutar la fase 1 para entrar en comunicación.

2. Repetir la fase 2.

NOTA: Si se recibe una llamada durante la programación, es necesario responder y, luego, seguir.

Variación de los tonos de llamada del monitor

1. Mantener presionado el pulsador  hasta que se emita un sonido de confirmación (la operación sólo es posible con la instalación en reposo; si no lo está, el led de señalización parpadea para avisar al usuario).

2. Presionar y soltar el pulsador  :

Una vez (se emite un tono de confirmación) para cambiar el tono de llamada desde la unidad externa.

Dos veces (se emiten dos tonos de confirmación) para cambiar el tono de llamada desde la centralita.

Tres veces (se emiten tres tonos de confirmación) para cambiar el tono de llamada intercomunicante desde unidad interna.

Cuatro veces (se emiten cuatro tonos de confirmación) para cambiar el tono de llamada desde el timbre de planta.

Si se sigue presionando el pulsador  , se repite la secuencia descrita anteriormente.

3. Presionar y soltar el pulsador 1 para desplazar en secuencia los diferentes tonos de llamada disponibles.

4. Presionar el pulsador 2 para confirmar la elección del último tono de llamada escuchado y para salir en cualquier momento de la modalidad de variación del tono de llamada del monitor. Al salir de la modalidad de variación del tono de llamada del monitor se emite un sonido de confirmación.

Programaciones especiales Art. 4680KC

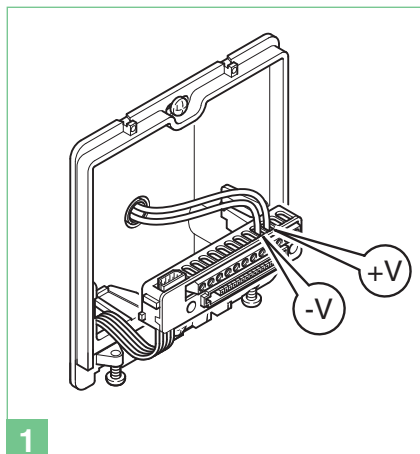

1

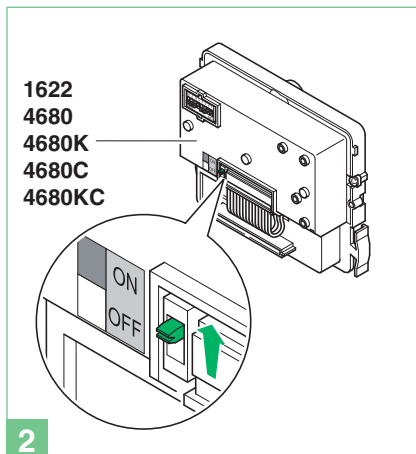

2

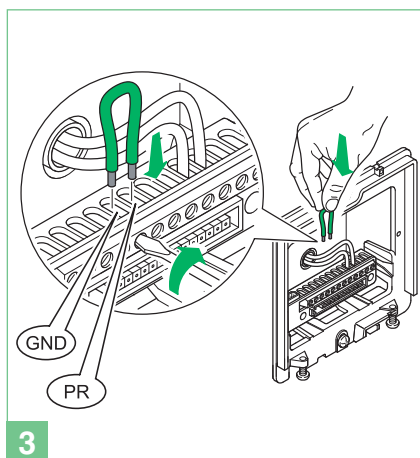

3

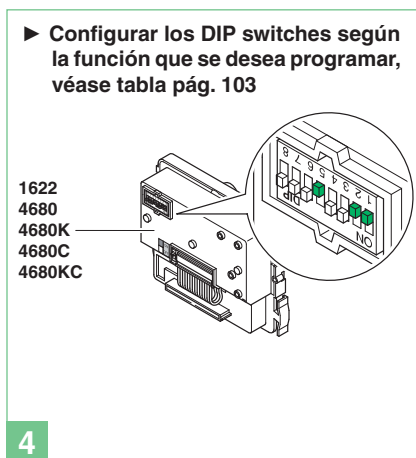

4

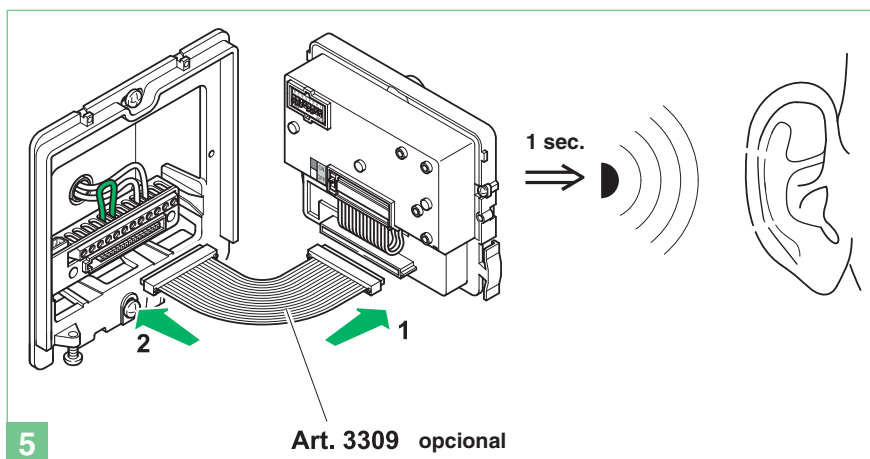

5

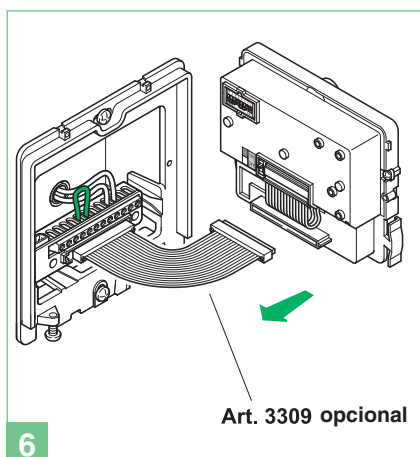

6

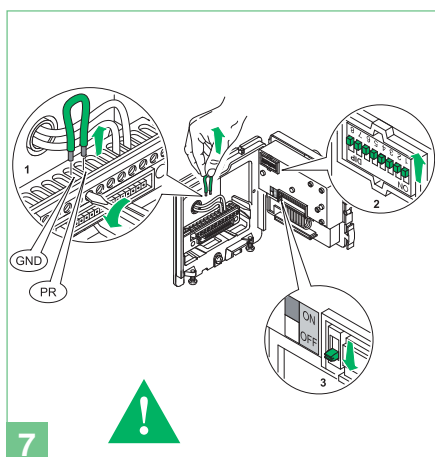

7

Cod.	Dip switch ON	
Resistencia antiempañamiento		
213	1,3,5,7,8	OFF (valor predefinido)
212	3,5,7,8	ON

Mensajes audiovisuales		
210	2,5,7,8	Sólo mensajes visuales
211	1,2,5,7,8	Sueco
214	2,3,5,7,8	OFF (predefinido)
215	1,2,3,5,7,8	Italiano
216	4,5,7,8	Francés
217	1,4,5,7,8	Español
218	2,4,5,7,8	Holandés
219	1,2,4,5,7,8	Griego
220	3,4,5,7,8	Inglés
221	1,3,4,5,7,8	Alemán
222	2,3,4,5,7,8	Portugués

Cerradura		
223	1,2,3,4,5,7,8	Mando de la cerradura en SE con CA (predefinido)
224	6,7,8	Mando de la cerradura en SE con CA potenciada
225	1,6,7,8	Mando de la cerradura en SE con CC
245	1,3,5,6,7,8	Tiempo de la cerradura: 2 s + tono desactivado (predefinido)
246	2,3,5,6,7,8	Tiempo de la cerradura: 4 s
247	1,2,3,5,6,7,8	Tiempo de la cerradura: 8 s
248	4,5,6,7,8	Tono de confirmación de la cerradura: activado
251	1,2,4,5,6,7,8	Relé C. NC. NA en paralelo a SE (predefinido)
252	3,4,5,6,7,8	Abrepuertas siempre activo (predefinido)
253	1,3,4,5,6,7,8	Abrepuertas activo sólo para el usuario que ha recibido la llamada

Gestión del mando actuador		
NOTA: en la instalación no tiene que haber el Art. 1256 en modalidad actuador genérico.		
229	1,3,6,7,8	Activación del relé C.NC.NA en el mando del actuador: 2 s
230	2,3,6,7,8	Activación del relé C.NC.NA en el mando del actuador: 4 s
231	1,2,3,6,7,8	Activación del relé C.NC.NA en el mando del actuador: 8 s
228	3,6,7,8	Mando actuador en la línea serial S: desactivado (predefinido)
227	1,2,6,7,8	Mando actuador en la línea serial S: activado

Funciones de la instalación		
232	4,6,7,8	Tiempo de espera de la respuesta: 60 s (predefinido)
233	1,4,6,7,8	Tiempo de espera de la respuesta: 120 s
234	2,4,6,7,8	Tiempo de espera de la respuesta: 30 s
235	1,2,4,6,7,8	Tiempo de conversación: 90 s (predefinido)
236	3,4,6,7,8	Tiempo de conversación: 180 s
237	1,3,4,6,7,8	Autoencendido: activado (predefinido)
238	2,3,4,6,7,8	Autoencendido: desactivado

239	1,2,3,4,6,7,8	Tono de confirmación de llamada del usuario: activado (predefinido)
240	5,6,7,8	Tono de confirmación de llamada del usuario: desactivado
243	1,2,5,6,7,8	Tiempo de espera reset: 10 s (predefinido)
244	3,5,6,7,8	Tiempo de espera reset: 1 s
208	5,7,8	Reset tras abrepuertas en audio: activado (predefinido)
209	1,5,7,8	Reset tras abrepuertas en audio: desactivado
249	1,4,5,6,7,8	Envío de llamada: una vez (predefinido)
250	2,4,5,6,7,8	Envío de llamada: tres veces

254	2,3,4,5,6,7,8	Restablecimiento predefinido
-----	---------------	-------------------------------------

Avisos

- Instalar o equipamento cuidadosamente, seguindo as instruções dadas pelo fabricante e em conformidade com a legislação em vigor.
- Todos os aparelhos devem ser exclusivamente destinados ao uso para o qual foram concebidos. **Comelit Group S.p.A.** declina qualquer responsabilidade pelo uso impróprio do equipamento, quaisquer modificações efectuadas por qualquer motivo sem autorização prévia, como também pelo uso de acessórios e materiais que não tenham sido originariamente fornecidas pela Comelit Group S.p.A.
- Todos os produtos estão em conformidade com os requisitos das directivas 2006/95/CE (que substituem as directivas 73/23/CEE e as alterações subsequentes). A prova é a marca **CE** nos produtos.
- Evitar colocar os fios da coluna na proximidade de cabos de alimentação (230/400 V).
- Não introduzir objectos, nem derramar líquidos no interior do dispositivo.
- As intervenções de instalação, montagem e assistência a aparelhos eléctricos devem ser realizadas exclusivamente por electricistas especializados.
- Cortar a alimentação eléctrica antes de realizar qualquer tipo de manutenção.
- Ligar a moldura à terra (consultar a Fig.)
- Não manter premido o gancho do som com o auscultador levantado.
- A câmara não deve ser instalada à frente de grandes objectos luminosos ou em locais onde a pessoa filmada esteja em contraluz. Para resolver o problema anterior, sugere-se modificar a altura da instalação da câmara, geralmente 160-165 cm, a uma altura de 180 cm e orientar a objectiva para baixo de forma a melhorar a qualidade da captura.
- As câmaras com sensor CCD a cores apresentam, em condições de pouca luminosidade, uma sensibilidade inferior à das câmaras a preto e branco. Sugere-se, portanto, em ambientes pouco iluminados, arranjar uma fonte de iluminação adicional.

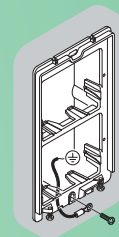

Generalidades	105
Posto externo	105
Art. 4879KC	105
Art. 1207	105
Instalação do posto externo	105
Introdução dos cartões porta nomes	106
Postos internos	107
Montagem do posto interno Magis	107
Remover o monitor	107
Art. 6402E	108
Descrição do monitor	108
Art. 2608	109
Instalação do telefone intercomunicador Art. 2608	109
Indicações gerais de instalação e funcionamento	110
Tabela de distâncias de funcionamento	110
Funcionamento	110
Descrição das configurações e funcionamento dos botões	111
Configurações do monitor Art. 6402E e telefone intercomunicador Style	111
TAB. A Endereços da coluna	111
Descrição das funções das teclas	111
Monitores suplementares principais ou secundários	112
Utilização do kit em instalações com porta principal	112
Programação dos botões Art. 4680KC	113
Configurações dos botões predefinidos	113
Avisos gerais sobre a programação dos botões	113
Programações dos botões para o actuador geral ou com endereço	114
Programação para a chamada de intercomunicação	114
Programação/cancelamento do endereço de intercomunicação (apenas para intercomunicação selectiva)	114
TAB. B Endereços de intercomunicação selectiva	114
Programação dos botões para a chamada de intercomunicação	115
Programação dos botões para outras funções	115
TAB. C Endereços da coluna	116
Reinicialização da programação	116
Programação range/campainhas	117
Programação da entrada IN1 para indicação luz indicadora/alarme/abertura da porta/actuador	118
Programação directa da chamada de intercomunicação	119
Variante das campainhas do monitor	119
Programações especiais Art. 4680KC	120
Esquemas de ligação	
MSK/018IC Esquema básico para kits bifamiliares Art. 8172IMC com ligação em cascata. Colocação em funcionamento/controlo das tensões do aparelho quando está em repouso.....	121
MSK/013IBC Esquema base para kits bifamiliares Art. 8172IMC com ligação em derivação.....	122
MSK/014IBC Esquema para kits bifamiliares Art. 8172IMC ampliados com um segundo Art. 4879KC. Ligação em derivação.....	123
MSK/014IAC Esquema para kits bifamiliares Art. 8172IMC ampliados com um segundo Art. 4879KC. Ligação em cascata.....	124
MSK/018I/AC Esquema para kit bifamiliares com alimentador suplementar Art.1595	125
MSK/019IC Utilização do módulo da câmara separada Art. 1259C	126
PXK/EC Ligação do relé actuador Art. 1256	127
MSK/EN/109IC Esquema para a ligação com a porta principal de 2 a 9 Magis Kits através do Art. 4834/9.....	128
MSK/EN/110IC Esquema para a ligação com a porta principal de 30 Magis Kits (máximo). Ligação Magis em cascata com Art. 1424.....	130
SB2/AAR Ligação do amplificador vídeo Art. 4833C	132
MSK/HCA Adição de um monitor principal em paralelo. Ligação em cascata	132
MSK/IC Adição de um monitor principal em paralelo. Ligação em derivação	133
MSK/A20S Ligação em cascata do terceiro monitor principal com alimentação local.....	133
MSK/A23S Ligação em derivação de 2 monitores principais e de 2 monitores secundárias com o mesmo código de utilizador.....	134
MSK/A21S Ligação em cascata de 2 monitores principais e de 1 monitor secundário com o mesmo código de utilizador	134

MSK/AAE Ligação de telefones intercomunicadores suplementares em derivação do monitor.....	135
MSK/AAD Ligação de telefones intercomunicadores suplementares em cascata do monitor.....	135
MSK/FC Ligação de telefones intercomunicadores suplementares em cascata do monitor	136
SB/X3 Utilização do botão P1 para vários usos (Art. 2608).....	136
SB2V/AAK Ligação de dispositivos de repetição da chamada (Art. 1229 ou Art. 1122/A)	137
Variante para ligação da campanha externa	137
Utilização da entrada IN1 como contacto para a indicação LUZ INDICADORA/ALARME/ABERTURA DA PORTA/ACTUADOR. Activação perante fecho entre IN1 e CFP2.....	138
Utilização da entrada IN1 como contacto para a indicação LUZ INDICADORA/ALARME/ABERTURA DA PORTA/ACTUADOR. Activação na presença de tensão comparativamente a IN2	138
SB2/AAM2 Utilização do botão P1 para vários usos	139
PXK/RTNP Utilização do relé do posto exterior para abertura de porta ou comando actuador (vide Programações especiais da Pág 120: Gestão do comando actuador)	139
PXK/SNP Variante com fechadura de segurança e alimentação suplementar	140
Utilização da rede RC para filtrar a fechadura nos contactos do relé	140
PXK/DO Variante para a utilização da indicação porta aberta.....	141

Generalidades

Os Kits vídeo-intercomunicadores bifamiliares Art. 8172IMC podem ser utilizados em edifícios familiares ou comerciais onde for necessário um controlo eficiente do acesso através de simples operações de instalação. De facto, são suficientes 2 condutores entre o posto externo e o(s) monitor(es) interno(s) para activar o sistema (chamada, som, vídeo, acendimento automático), 2 fios para alimentar o posto externo e a fechadura eléctrica e 2 fios para alimentar o posto interno vídeo-intercomunicador.

Adicionalmente, a Comelit disponibiliza uma série de acessórios que resolve facilmente todas as exigências da instalação e para além de acessórios interessantes do tipo padrão, é possível aumentar a instalação adicionando vídeo-intercomunicadores e/ou telefones intercomunicadores e/ou postos externos. Deste modo, é possível chegar a um máximo de 2 postos externos com 8 postos internos entre telefones intercomunicadores e vídeo-intercomunicadores para a configuração bifamiliar.

Através de configurações apropriadas é possível realizar comunicações de intercomunicação monofamiliares (isto é, entre utilizadores com o mesmo código de utilizador), utilizando quer vídeo-intercomunicadores, quer telefones intercomunicadores.

Podem ser ligados kits adicionais a uma porta principal Simplebus e/ou a uma central Art. 1998A.

Posto externo

Art. 4879KC

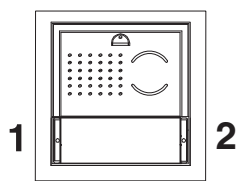

Art. 4879KC

Características técnicas

Ligação ao monitor com 2 fios para áudio, vídeo, abertura da porta e chamada, e 2 fios para alimentação do Art. 1207.

Câmara orientável de alta sensibilidade com sensor CCD 1/3".
Cartões porta nomes com iluminação por luz indicadora, seleccionável entre azul, branco e desligado.
Regulação do volume do altifalante.
Dimensão da caixa de embutir: 118x118x45 mm.
Os botões do Art. 4879KC são configurados na fábrica para realizar a chamada aos endereços 1 (botão esquerdo) e 2 (botão direito).
Dimensão do posto externo: 112x89,5x40 mm.

Descrição da bateria de bornes

LL ligação do monitor (vídeo, chamada, áudio, abertura da porta).
V+ V- alimentação do posto externo.
RTE entrada abertura da porta local com temporizador.
DO entrada indicação porta aberta.
PR borne de programação.
GND borne negativo a utilizar na fase de programação.
NO NC COM contactos do relé de 10 A.
SE Ligação da fechadura eléctrica.

Art. 1207

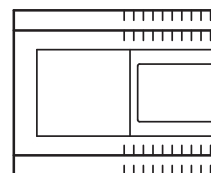

Características técnicas

O transformador possui 2 saídas: uma para alimentar o posto externo e a fechadura eléctrica, e outra para alimentar o monitor.
Dimensões: 105x95x65 mm (6 módulos DIN).
Protecção contra curtos-circuitos e sobrecargas.

Descrição da bateria de bornes

L $\frac{1}{2}$ N entrada alimentação eléctrica 110-240 V AC.
+22V 0V saída DC para alimentação do monitor.
+33V 0V saída DC para o posto externo e a fechadura eléctrica.

Instalação do posto externo

► Deixar colocada a protecção da instalação.

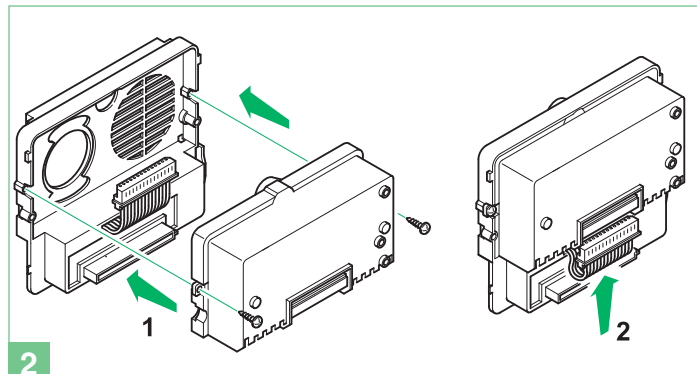
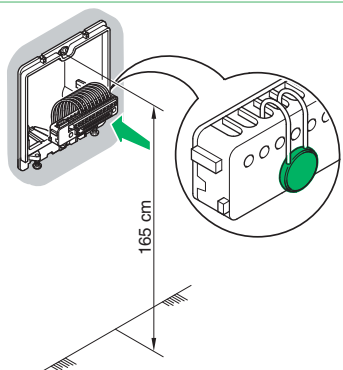

► Selecção da iluminação das luzes indicadoras dos cartões porta nomes.

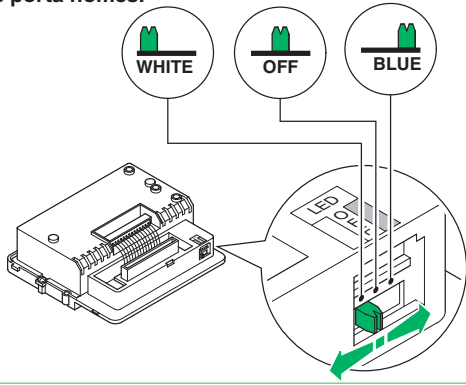

3

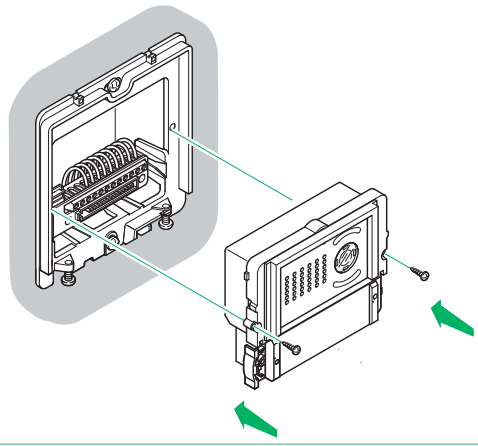

4

Posição alternativa do microfone

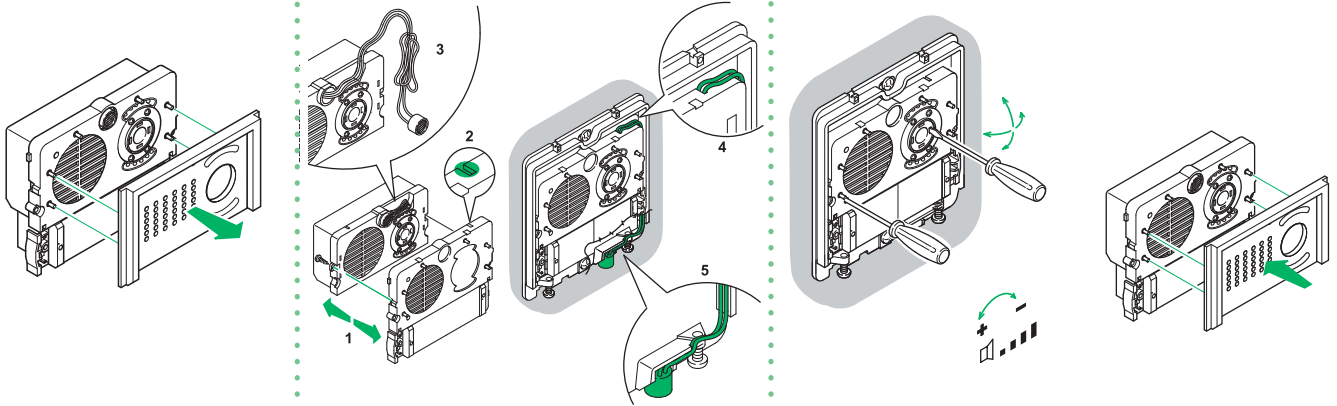

4A

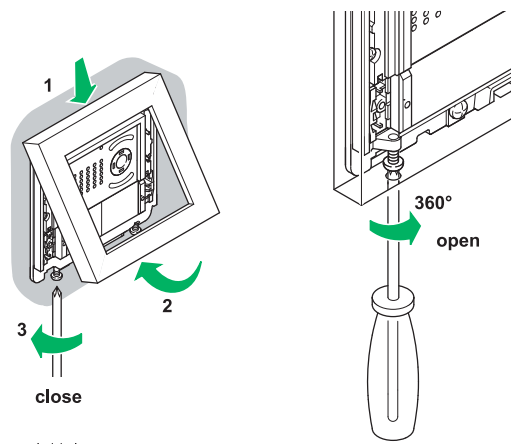

5

Introdução dos cartões porta nomes

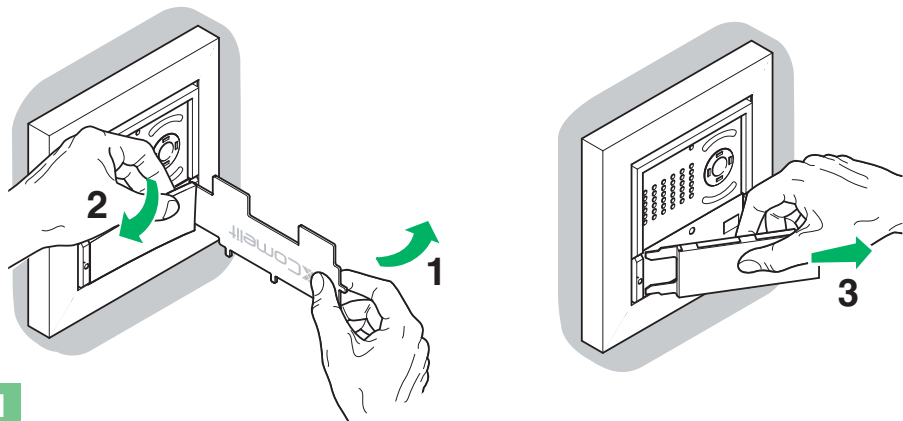

1

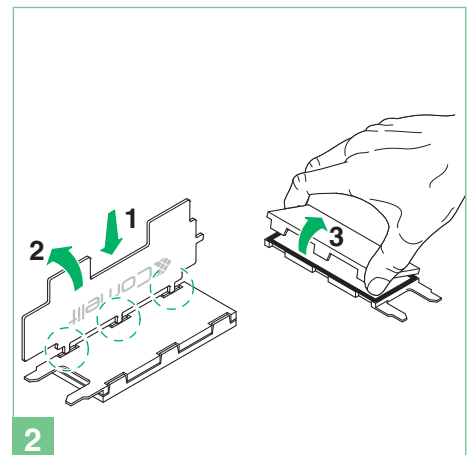

2

► Centrar o cartão para evitar infiltrações

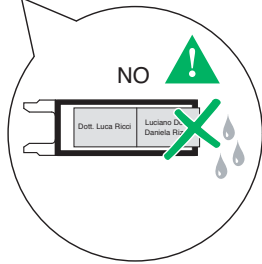

3

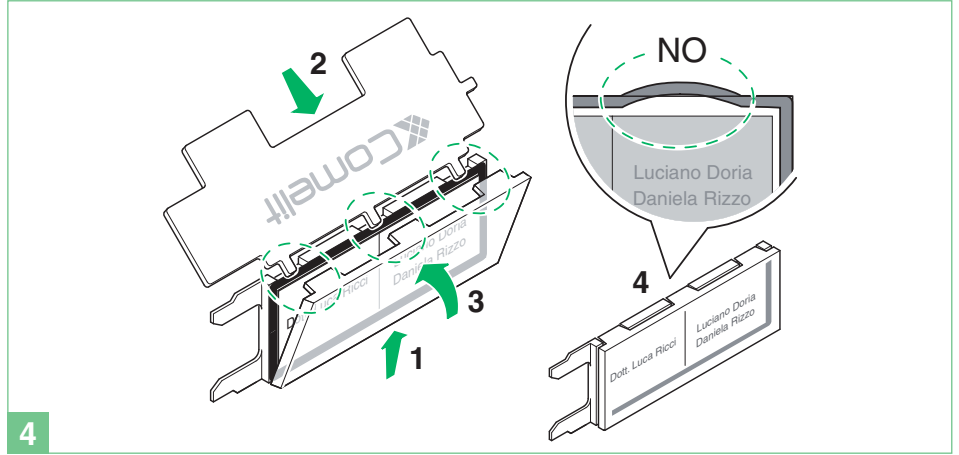

4

Postos internos

Montagem do posto interno Magis

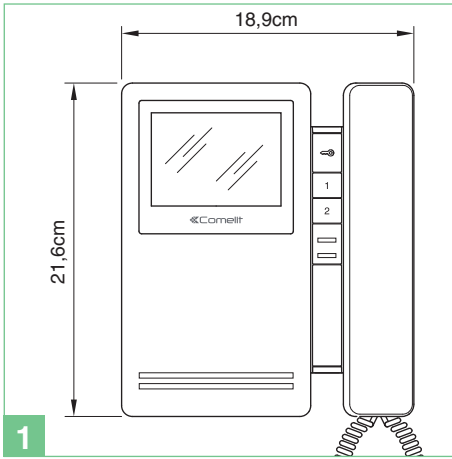

1

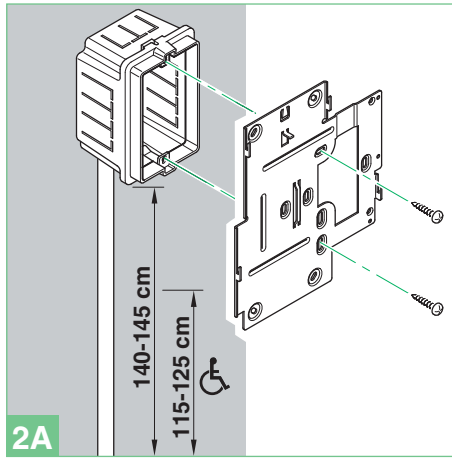

2A

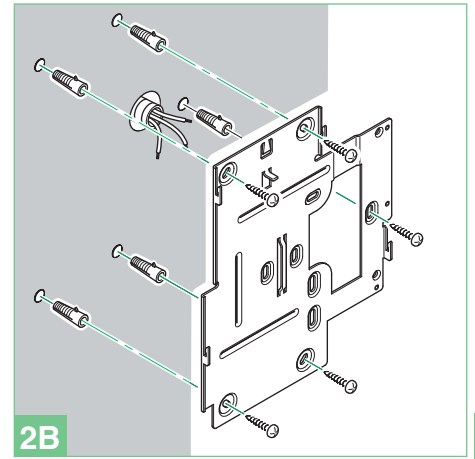

2B

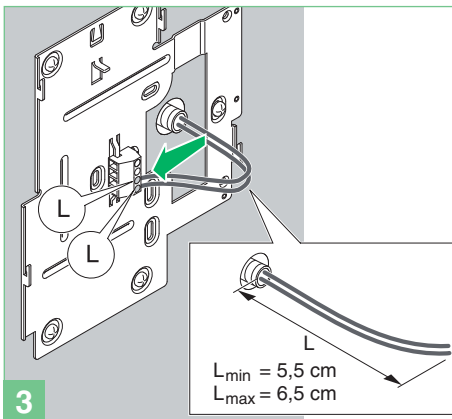

3

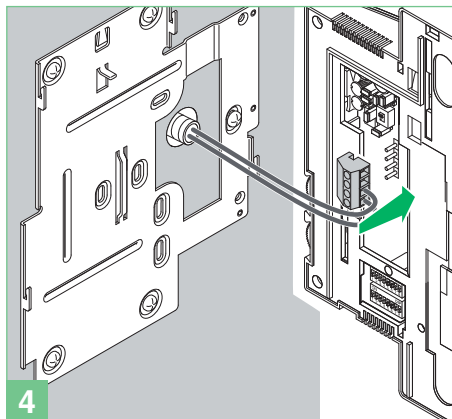

4

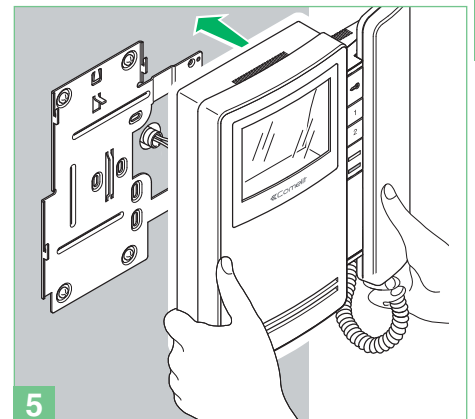

5

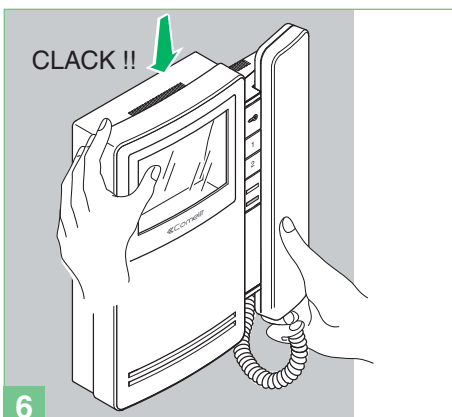

6

Remover o monitor

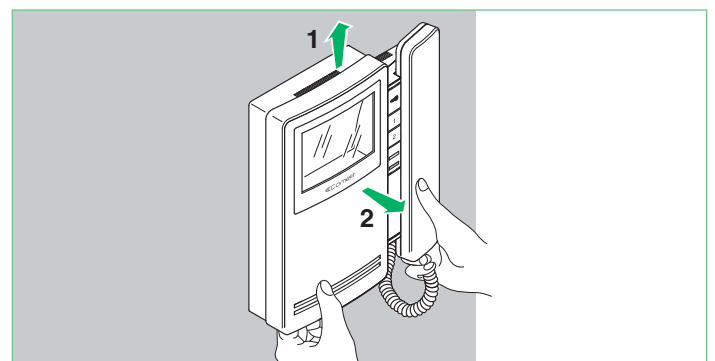

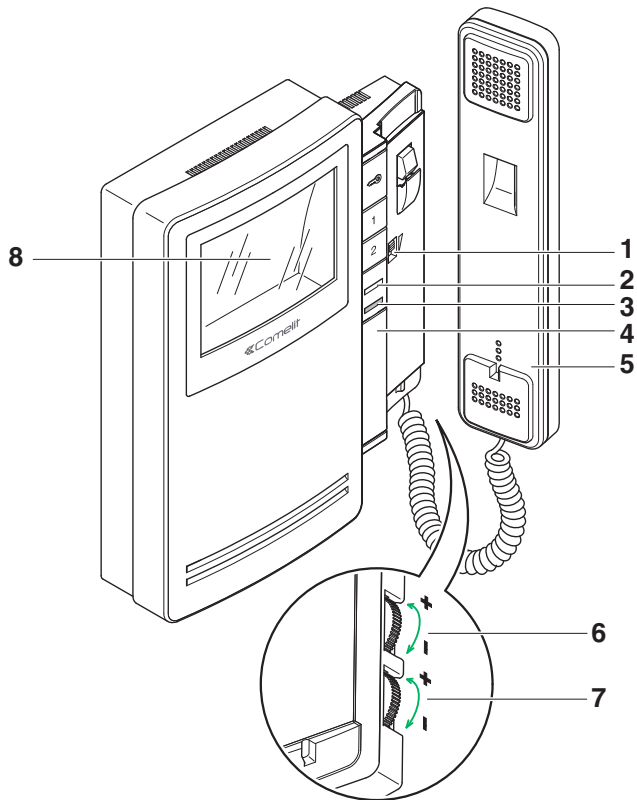

Descrição monitor:

- 1 Regulação do volume de chamada/selectora da função privacidade (por serviço privacidade entende-se a exclusão da chamada do posto exterior e de telefones intercomunicadores e vídeo-intercomunicadores. A activação da função privacidade é evidenciada pelo aparecimento de um indicador vermelho ao lado do selector).
- 2 Luz indicadora de equipamento ocupado/função médico activada/ porta aberta.
- 3 Indicador vermelho - privacidade activada.
- 4 Espaço para alojar botões adicionais com o acessório Art. 6333, Art. 6434.
- 5 Auscultador do monitor (levantar o auscultador para iniciar a comunicação).
- 6 Manípulo de regulação da intensidade da cor.
 - ▶ Rodar para a esquerda para aumentar o valor.
- 7 Regulação de luminosidade.
 - ▶ Rodar para a esquerda para aumentar o valor.
- 8 Ecrã a cores 3,5".

Descrição dos botões:

- ☞ Botão de abertura da porta.
- 1 Tecla 1 actuador geral (programável).
- 2 Tecla 2 acendimento automático (programável).

Descrição do monitor

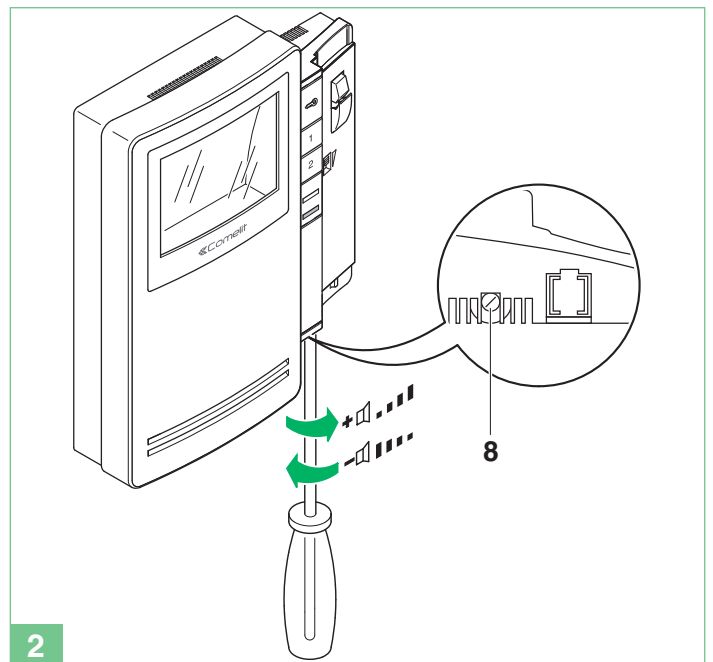
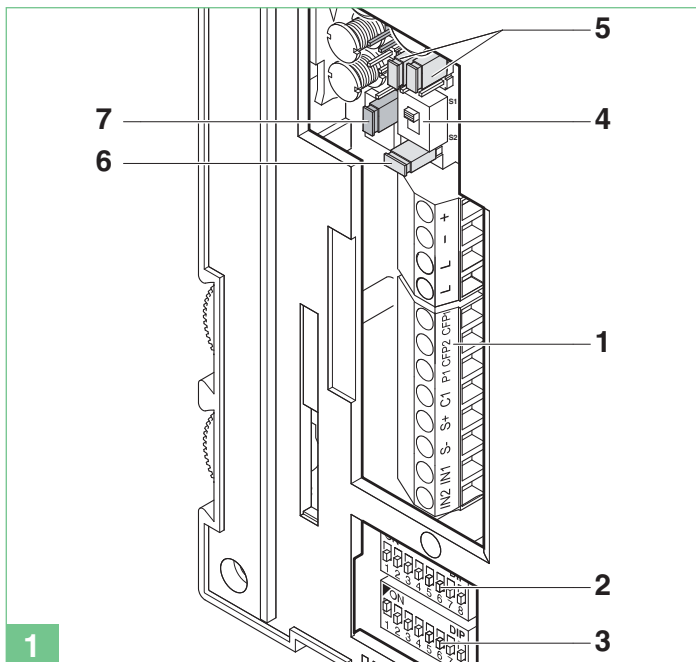

Bateria de bornes de ligação da instalação:

- + - Bornes para alimentação.
- L L Bornes para ligação à linha bus.
- CFP1 CFP2 Entrada de chamada de andar local.
- P1 C1 Bornes do botão 1 para vários usos.
- Para obter um contacto C.NO. (24 V-100 mA máx.) colocar os comutadores de derivação CV3 e CV4 na posição B.**
- S+ S- Bornes para dispositivo de repetição de chamada.
- IN1 IN2 Entrada para luz indicadora (programável).
- 2 S1 Microinterruptores para programar o código de utilizador.
- 3 S2 Microinterruptores para programar os botões e as funções (identificado por um canto vermelho):
- DIP 1-2-3-4 para programar as funções dos botões.
- DIP 5-6 acesso às programações.

DIP 7 para gerir a alimentação eléctrica (consultar esquemas e variantes da pág. 121) predefinição = OFF.

DIP 8:

- ON suporte secundário.
- OFF suporte principal (predefinido).
- 4 SW3 Selector para o modo Simplebus 1 (S1-predefinição) o Simplebus 2 (S2).
- 5 CV3 CV4 Comutador de derivação para libertar o botão 1 (contacto C.NO. 24 V-100 mA máx.).
- A botão 1 Actuador geral (predefinição) ou programável.
- B botão 1 para vários usos.
- 6 CV5 Comutador de derivação fecho vídeo.
- 7 CV6 selector para utilizar a entrada IN 1 (consultar pág. 138).
- 8 Regulação do volume do altifalante (apenas para a programação do som de intercomunicação).

Art. 2608

Não é utilizável como função de intercomunicação.
O telefone intercomunicador deve ser sempre instalado utilizando o Art. 1214/2C como ilustrado no esquema de ligação MSK/FC na pág. 136.

- 1 Indicador da função Privacidade.
- 2 Selector de 3 posições para campanha/serviço privacidade:
Posição alta: campanha no volume máximo.
Posição central: campanha no volume médio.
Posição baixa: activação do serviço privacidade.
(O serviço privacidade significa a exclusão do som de chamada do posto externo e da central; a activação da função de privacidade encontra-se indicada por um indicador vermelho que aparece no canto superior direito).
- 3 Regulação do volume do microfone.
- 4 Microinterruptores para a configuração do código de utilizador.
- 5 Bornes de ligação da instalação:
L L Ligação de linha Bus.
CFP CFP Entrada chamada de andar local.
P1 C1 Bornes do botão P1 para vários usos (contacto C. NO. 24 V-100 mA máx.) (remover CV1 e CV2, consultar a variante SB/X3 na pág. 136).
S+ S- Bornes para o dispositivo de repetição de chamada.
- 6 **CV1 CV2** Comutador de derivação a ser removido para ter contacto limpo C. NO. no botão P1.
- 7A/7BJP1 Comutador de derivação para seleccionar a função chamada à central (posição C)/Actuador geral (posição A) do botão P1.

Descrição dos botões:

- ☞ Botão de abertura da porta.
- P1** Botão P1 chamada central/actuador geral/ botão para vários usos disponível na bateria de bornes (P1 C1).

Limpar com um pano humedecido em água. Não utilizar álcool e outros produtos agressivos.

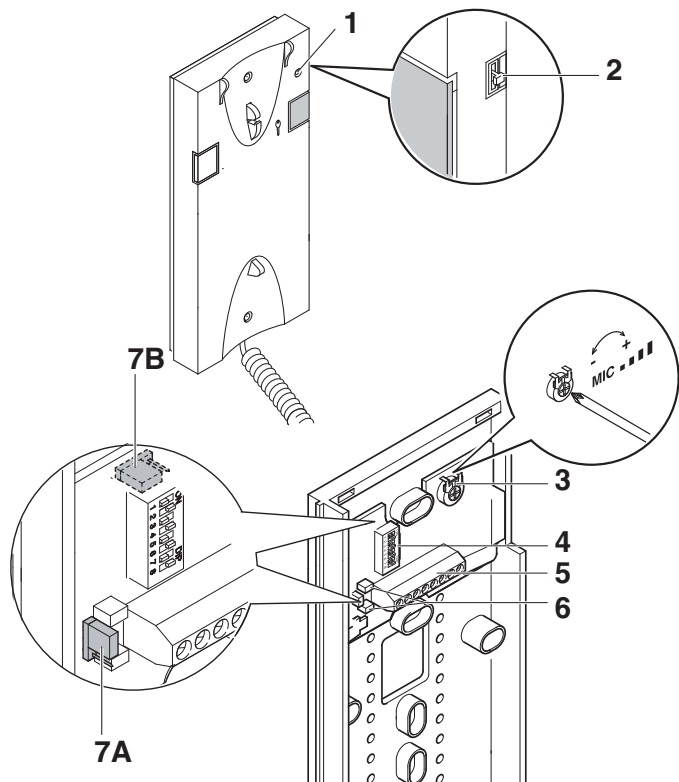

Instalação do telefone intercomunicador Art. 2608

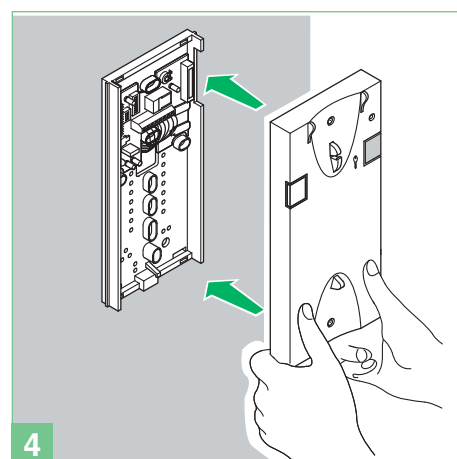
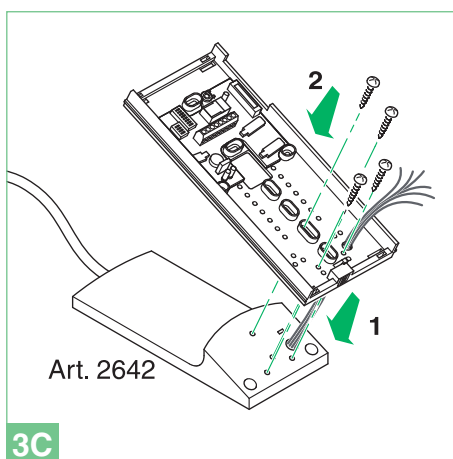
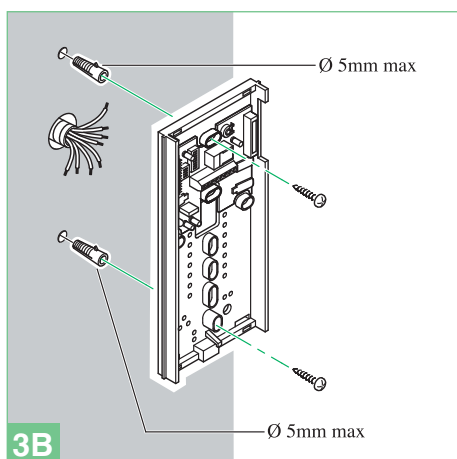
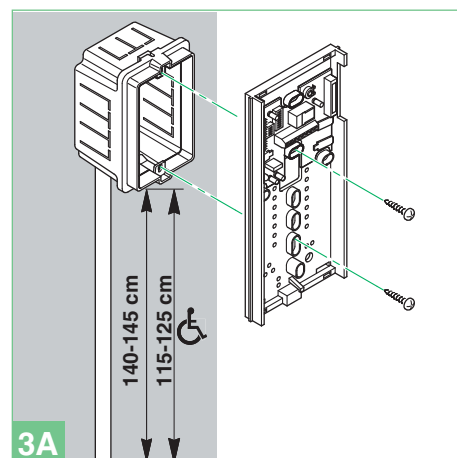
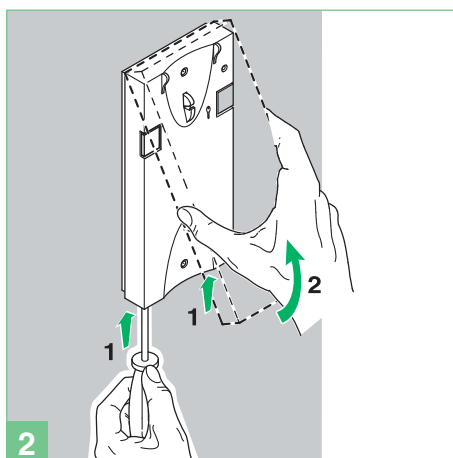
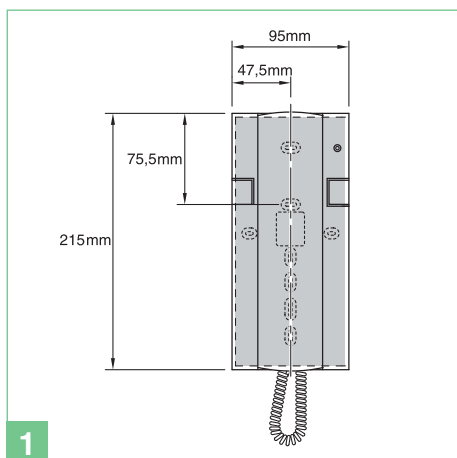

Indicações gerais de instalação e funcionamento

A distância máxima total entre o posto externo e o monitor mais afastado é de 400 m (com amplificador Art. 4833C).

A soma total do número de postos internos com o mesmo código de utilizador e do número de dispositivos de repetição de chamada ligados aos postos internos não pode ser superior a 4.

Ligar apenas um dispositivo de repetição de chamada para cada posto interno.

A distância máxima da ligação entre ponto interno e dispositivo de repetição de chamada de 20 m; usar cabo blindado para a ligação e não passar os cabos na proximidade de cargas indutivas pesadas ou cabos de alimentação (230 V / 400 V).

Tabela de distâncias de funcionamento

		A/G MAX	B/E MAX	C MAX	D MAX	F MAX	Art. 1216
Comelit Art. 4577 1 mm ² (Ø 1,2 mm AWG 17)		50 m (165 feet)	50 m (165 feet)	200 m (655 feet)	100 m (330 feet)	150 m (495 feet)	
Comelit Art. 4576-4578	0,5 mm ² (Ø 0,8 mm AWG 20) bus		25 m (85 feet)	200 m (655 feet)	100 m (330 feet)	150 m (495 feet)	
	1,5 mm ² (Ø 1,4 mm AWG 15) power	75 m (245 feet)	100 m (330 feet)				
UTP5 cat. 5 0,2 mm ² (Ø 0,5 mm AWG 24)				190 m (625 feet)	60 m (195 feet)	150 m (495 feet)	
0,28 mm ² (Ø 0,6 mm AWG 23)		5 m (15 feet)		190 m (625 feet)	60 m (195 feet)	150 m (495 feet)	
0,5 mm ² (Ø 0,8 mm AWG 20)		25 m (85 feet)	25 m (85 feet)	190 m (625 feet)	60 m (195 feet)	150 m (495 feet)	
1 mm ² (Ø 1,2 mm AWG 17)		50 m (165 feet)	50 m (165 feet)	190 m (625 feet)	60 m (195 feet)	150 m (495 feet)	
1 mm ² (Ø 1,2 mm AWG 17)		50 m (165 feet)	50 m (165 feet)	120 m (395 feet)	40 m (130 feet)	100 m (330 feet)	
1,5 mm ² (Ø 1,4 mm AWG 15)		75 m (245 feet)	100 m (330 feet)	190 m (625 feet)	60 m (195 feet)	150 m (495 feet)	
2,5 mm ² (Ø 1,8 mm AWG 13)		100 m (330 feet)	150 m (495 feet)	190 m (625 feet)	60 m (195 feet)	150 m (495 feet)	

PT

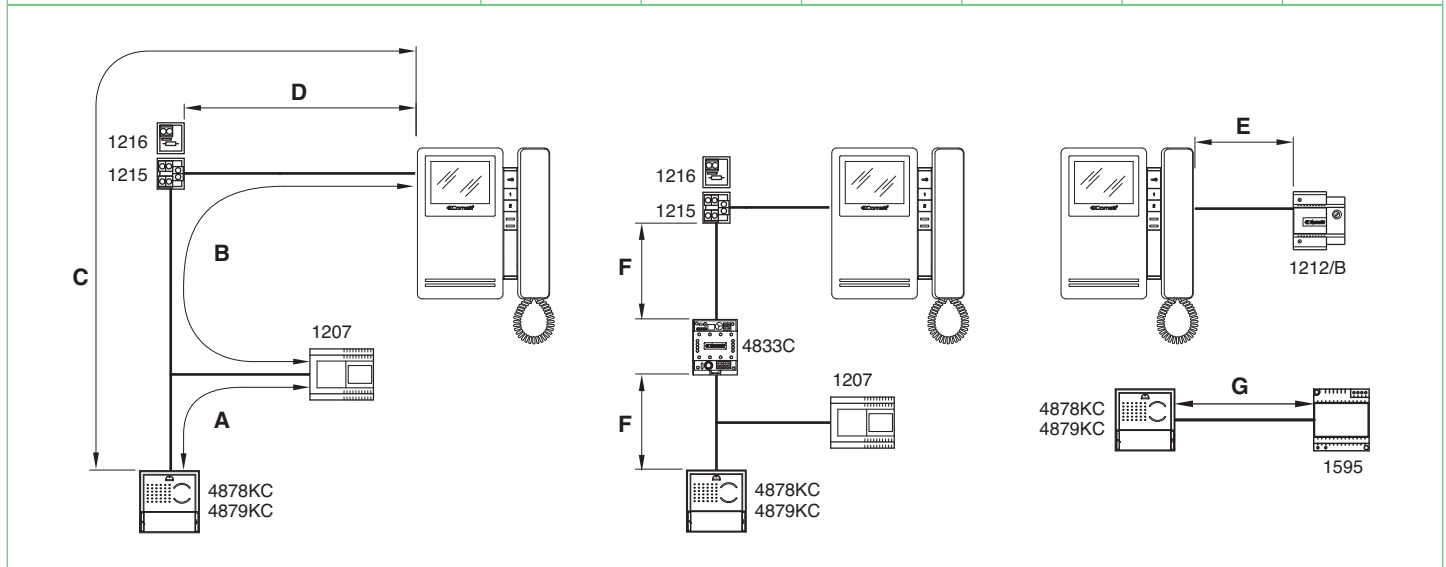

Funcionamento



Em caso de curto-circuito persistente na linha bus, o posto externo emite um som de sinalização intermitente.

O visitante, ao premir a tecla de chamada, acende a luz que o ilumina, activa a campainha interna de chamada (se a função privacidade não estiver activada), e a sua imagem será exibida no(s) monitor(es) principal(ais) durante cerca de 60 segundos.

A duração máxima da conversação entre posto externo e posto interno é de 90 segundos.

No posto externo ouve-se um som de chamada a entrar; se em sistemas com 2 ou mais entradas, no momento da chamada, o posto externo emitir o som de ocupado em vez do som de uma campainha, significa que está a decorrer outra comunicação com outro posto externo.

Para a programação dos endereços de utilizadores diferentes daqueles programados de fábrica (1 e 2), consultar a pág. 111.

Para as funções de intercomunicação do sistema Magis kit, consulte a pág. 114.

Descrição das configurações e funcionamento dos botões

Configurações do monitor Art. 6402E e telefone intercomunicador Style

Posições dos microinterruptores do monitor Art. 6402E

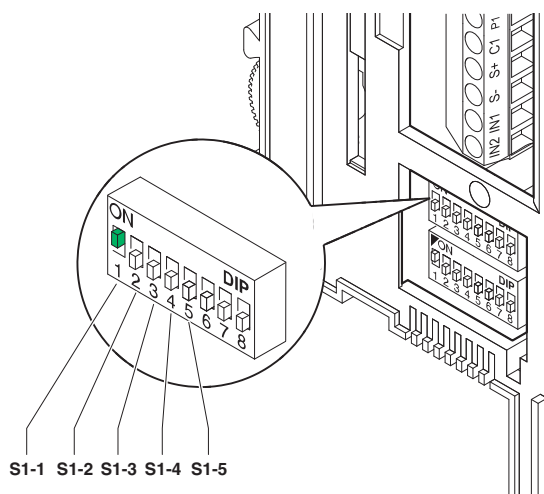

► Nos telefones intercomunicadores Art. 2608, Art. 2610 e Art. 2628 colocar os dip switches S1-6, S1-7, S1-8 em OFF.

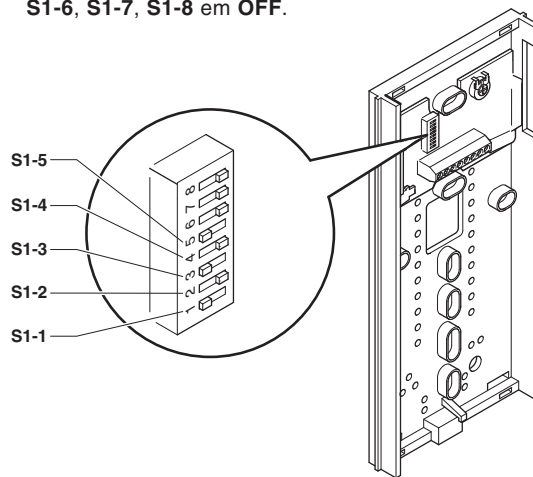

Os valores de S1-1, S1-2, S1-3, S1-4 e S1-5 definem o endereço de chamada do monitor e dos telefones intercomunicadores como indicado na seguinte tabela.

TAB. A Endereços da coluna

Código	S1	Código	S1	Código	S1	Código	S1
1		9		17		25	
2		10		18		26	
3		11		19		27	
4		12		20		28	
5		13		21		29	
6		14		22		30	
7		15		23			
8		16		24			

Descrição das funções das teclas

A chamada intercomunicante bifamiliar (entre intercomunicadores e/ou vídeointercomunicadores) é possível apenas se os dois utilizadores tiverem sido programados com códigos de chamada contíguos (marcados com a mesma letra AA..CC..OO na tabela de programação dos Micro-interruptores apresentada na página 111).

☞ **Abre-porta:** A pressão do botão Abre-porta activa o fecho ligado ao posto externo.

Actuador: A pressão do botão programado na modalidade Actuador permite a activação do Art. 1256 que pode ser utilizado, por exemplo, para accionar a abertura de portões, de portas basculantes ou para activar o módulo de câmaras cíclicas Art 1259C.

Botão Livre: A indicação Botão livre indica a possibilidade de utilizar o botão como contacto C.NO na bateria de bornes mediante oportunas programações, tal como ilustrado na variante SB2/AAM2na página 139.

Acendimento automático/pedido de vídeo

O acendimento automático pode ser desabilitado.

O acendimento automático é possível apenas com o aparelho em repouso.

O acendimento automático é aconselhado apenas em instalações com 1 ou 2 entradas.

Premir o botão 2 configurado neste modo permite visualizar no ecrã do monitor a imagem transmitida do posto externo, mesmo que não tenha sido feita nenhuma chamada.

Em sistemas equipados com 2 postos externos é possível visualizar alternativamente a imagem de um posto externo ou do outro (função "báscula"), através de sucessivas pressões no botão 2.

Em monitores secundários (DIP 8 de S2 em ON), o botão 2 tem também a função de pedido de vídeo, permite activar um monitor após uma chamada do posto externo.

Activação:

- premir o botão dedicado ao acendimento automático do monitor por um tempo superior a 4 segundos.
- » campanha de confirmação.

Desactivação:

- premir o botão dedicado ao acendimento automático do monitor por um tempo superior a 4 segundos.
- »ouem-se 4 sons de confirmação.

Acendimento:

- premir e soltar imediatamente o botão dedicado (botão 2 - se forem mantidas as configurações de fábrica).

Chamada à central

Premir o botão configurado neste modo permite enviar uma chamada para a central de portaria.

Chamada de intercomunicação monofamiliar

Esta função permite enviar uma chamada a outros aparelhos (vídeo-intercomunicadores e/ou telefones intercomunicadores) configurados no mesmo endereço de chamada.

► O destinatário da chamada, levantando o auscultador, entra em comunicação com o emissor da chamada. A comunicação termina quando se pousa o auscultador.

Uma chamada de intercomunicação não é prioritária relativamente a uma conversação/chamada com o posto externo.

Neste caso, durante uma tentativa de chamada de intercomunicação, a luz indicadora piscará por alguns segundos para sinalizar que o sistema está ocupado.

Chamada da unidade externa

De qualquer forma, uma chamada da unidade externa tem sempre prioridade sobre uma comunicação no intercomunicador (A activação

da comunicação com a unidade externa interrompe a conversação que estava a decorrer através do intercomunicador).

Neste caso, os utilizadores que já estão em comunicação ouvirão um som semelhante ao toque de chamada no auscultador, se esta for dirigida aos mesmos, ou então um som triplo.

► Para atender a chamada do posto externo, basta levantar o auscultador de qualquer aparelho livre ou pousar e levantar o auscultador da unidade ocupada numa comunicação de intercomunicação.

Médico

Esta função permite a activação automática da abertura da porta em chamadas do posto externo ao endereço do posto interno em qual a função foi activada.

Activação/desactivação:

► manter premido por 2 segundos o botão configurado para a função.
» A luz indicadora permanece acesa quando a função se encontra activa.

Monitores suplementares principais ou secundários

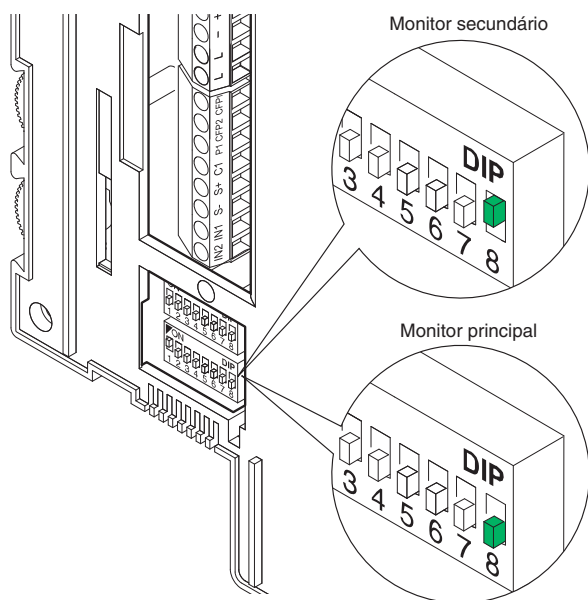

A programação do DIP 8 de S2 define se o suporte em questão será controlado como principal (P) ou secundário (S).

O posto externo pode gerir até 4 vídeo-intercomunicadores ou telefones intercomunicadores por cada botão de chamada.

Na configuração clássica de Magis Kit é possível ter no máximo 2 vídeo-intercomunicadores principais e 2 vídeo-intercomunicadores secundários para o botão de chamada, todos alimentados pelo mesmo Art. 1207.

Existe a possibilidade de gerir até 3 vídeo-intercomunicadores principais dentro da mesma unidade familiar (isto é, configurados com o mesmo código utilizador). Nesta configuração especial, os vídeo-intercomunicadores principais adicionais devem ser alimentados com o Art. 1212/B (consultar a variante MSK/HCA, MSK/IC na pág. 132, 133). Quando se efectua uma chamada do posto externo, o monitor que se acende é o vídeo-intercomunicador principal.

Os eventuais monitores secundários da mesma unidade familiar permanecerão desligados.

Ao atender a chamada do posto externo de um vídeo-intercomunicador secundário, a imagem será automaticamente visualizada no monitor.

Neste ponto o monitor do vídeo-intercomunicador principal será desligado e a imagem será visualizada no monitor do vídeo-intercomunicador no qual foi premido o botão 2 - acendimento automático/pedido de vídeo.

Para visualizar a imagem sem activar o áudio no posto externo, premir o botão 2 - acendimento automático/pedido de vídeo.

Utilização do kit em instalações com porta principal

Nos esquemas MSK/EN/109IC e MSK/EN/110IC na pág. 128, 131 é apresentada uma possível configuração de instalação que oferece a possibilidade de gerir até a um máximo de 30 Magis Kit a partir de um Art. 4680C - Art. 4680KC* colocado, por exemplo, na entrada de um complexo residencial.

Utilizando estes esquemas de instalação é possível chamar um dos Magis Kit da entrada principal, que tenha o Art. 4680C - Art. 4680KC* . Com esta configuração é necessário programar os botões do Art. 4680KC incorporados no Art. 4879KC como descrito no procedimento seguinte e

os postos internos com o código correspondente. Consultar a tabela na página 111.

Para mais informações sobre a integração dos Magis Kit em instalações Simplebus e para a programação da porta principal (Art. 4680C - Art. 4680KC*) consultar o catálogo (n. 140), e o manual técnico cod. 2G40000472.

*** Limitações de utilização do Art. 4680KC**

O Art. 4680KC gere as chamadas provenientes dos módulos de botões ou digitais APENAS se estiver entre o endereço 1 e o endereço 10.

Programação dos botões Art. 4680KC

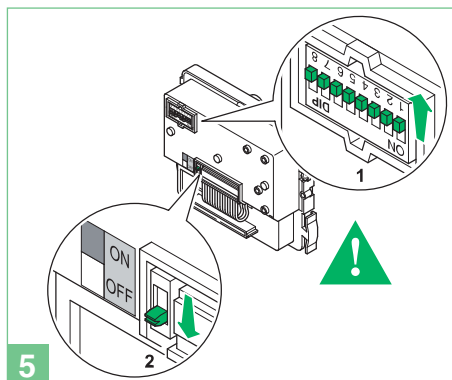
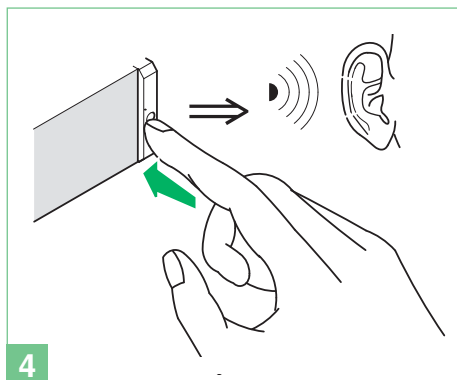
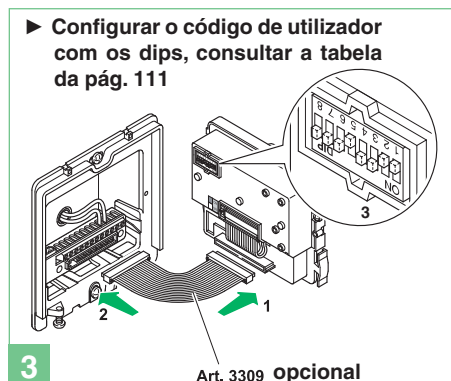
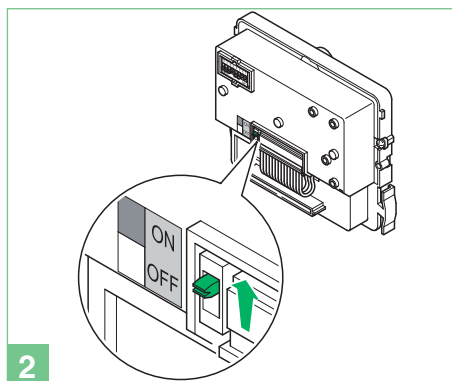
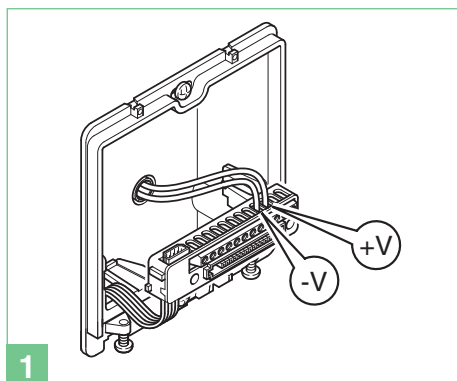

Configurações dos botões predefinidos

DIP S2				com Art. 6433, 6434							
DIP 1	DIP 2	DIP 3	DIP 4	P1	P2			P3	P4	P5	P6
0	0	0	0	CCS	AI	☞	☎	ACT	D	PAN	K
1	0	0	0	ACT	AI	☞	☎	INT	INTb	D	CCS
0	1	0	0	INT	AI			INTb	ACT	CCS	CCP
1	1	0	0	ACT	CCS			CCP	PAN	K	D
0	0	1	0	ACT	ACT	ACT		ACT	ACT	ACT	ACT
1	0	1	0	INT	ACT			CCS	CCP	INTb	PAN
0	1	1	0	AI	D			K	CCS	CCP	INTb
1	1	1	0	INTb	INT			AI	INT	PAN	D
0	0	0	1	CCS	PAN			D	AI	INT	INTb
1	0	0	1	K	CCS	☞		PAN	CCP	AI	INT
0	1	0	1	CCP	K			PAN	ACT	INT	AI
1	1	0	1	PAN	CCP			CCS	K	ACT	D
0	0	1	1	D	INTb			INT	ACT	AI	CCS
1	0	1	1	INT	INT			INT	INT	INT	INT
0	1	1	1	NULL	NULL	NULL	NULL	NULL	NULL	NULL	NULL
1	1	1	1						PROG		

Legenda

☞	Abertura da porta	CCS	Chamada à central	INTb	Intercomunicação bifamiliar - apenas para KIT
☎	Áudio	K	Chamada ao telefone intercomunicador do vigilante	NULL	Nenhuma função
ACT	Actuador	D	Médico	PROG	Funções programadas, consultar a pág. 113-114-115-116 Nesta programação dos dips, os botões gerem as funções programadas; os botões NÃO programados gerem as funções indicadas na linha 0000
AI	Acendimento automático	PAN	Pânico		
CCP	Chamada à central principal	INT	Intercomunicação programável geral ou selectiva - de série chamada monofamiliar para KIT e Simplebus Top		



Avisos gerais sobre a programação dos botões

Caso as configurações predefinidas (consultar a tabela da pág. 113) não reflectam as necessidades, é possível programar de modo diferente os botões segundo os procedimentos a seguir descritos.

No fim, colocar os DIPs 1-2-3-4 de S2 na combinação 1111 (programação PROG nas tabelas de configuração, pág. 113,114,115,116). Nesta

configuração dos DIPs, os botões gerem as funções programadas; os botões NÃO programados gerem as funções indicadas na linha 0000 (consultar a tabela da pág. 113). Repor em S1 a configuração do código de utilizador, consultar a tabela A da pág. 111.

Programações dos botões para o actuador geral ou com endereço

DIP S2				com Art. 6433, 6434						DIP S1			
DIP 1	DIP 2	DIP 3	DIP 4	P1	P2			P3	P4	P5	P6	ENDEREÇO ON 1 2 3 4 5 6 7 8	
0	0	0	0					ACT					
1	0	0	0	ACT									
0	1	0	0						ACT				
1	1	0	0	ACT									
0	0	1	0	ACT	ACT	ACT		ACT	ACT	ACT	ACT		
1	0	1	0		ACT								
0	1	1	0										
1	1	1	0										
0	0	0	1										
1	0	0	1										
0	1	0	1						ACT				
1	1	0	1							ACT			
0	0	1	1										
1	0	1	1										
0	1	1	1										
1	1	1	1										

Exemplo:

num monitor com código de utilizador 5 programação P1 = actuador geral, P2 = actuador com endereço com o código 125.

1. Colocar os DIPs 5-6 de S2 na combinação 01.

» a luz indicadora (verde) pisca.

2. Consultar a tabela da pág. 114 e escolher uma combinação onde surja a função de actuador (ACT) para os botões que se pretende programar.

EX.: para P1 = actuador geral configurar os DIPs 1-2-3-4 de S2 na combinação 1000 ou 1100 ou 0010 (P1 = ACT), configurar o dip de S1 na combinação 11111111, passar ao ponto 3.

EX.: para P2 = actuador com endereço com código 125, configurar os DIPs 1-2-3-4 de S2 na combinação 0010 ou 1010 (P2 = ACT), configurar S1 com o endereço 125 segundo a tabela C da pág. 116, passar ao ponto 3.

3. Premir e libertar o botão ao qual se pretende associar a função.

» a luz indicadora (verde) acende-se.

» som de confirmação no auscultador.

4. Para sair da programação, colocar os DIPs 5-6 de S2 na combinação 00.

» a luz indicadora (verde) desliga-se.

5. No final da programação, colocar os DIPs 1-2-3-4 de S2 na combinação 1111. Repor em S1 a configuração do código de utilizador, consultar a tabela C da pág. 116.

Programação para a chamada de intercomunicação



Chamada de intercomunicação geral e selectiva **NÃO** são compatíveis na mesma coluna.

Programação/cancelamento do endereço de intercomunicação (apenas para intercomunicação selectiva)

S1	! 2)						S2	3)
	DIP 1	DIP 2	DIP 3	DIP 4	DIP 5	DIP 6		
! 1) Programação; configurar o código, TAB. B pág. 114	0	0	0	1	1	1	 	
Cancelar DIP ON 	1	1	1	1	1	1	 	2 sec



Tomar nota da configuração de S2, S1 e repor no final da programação.

TAB. B Endereços de intercomunicação selectiva

Código	Dip switch ON	S1	Código	Dip switch ON	S1	Código	Dip switch ON	S1
1	1		4	4		7	7	
2	2		5	5		8	8	
3	3		6	6				

É necessário configurar o endereço de intercomunicação em todos os postos internos da coluna.

É possível associar o mesmo endereço de intercomunicação a um máx. de 3 postos internos.

Para a chamada de grupo, seleccionar em simultâneo os códigos de intercomunicação desejados (máx. 3).

Programação dos botões para a chamada de intercomunicação

DIP S2				com Art. 6433, 6434				DIP S1					
DIP 1	DIP 2	DIP 3	DIP 4	P1	P2			P3	P4	P5	P6	ENDEREÇO 	
0	0	0	0										
1	0	0	0					INT	INTb				
0	1	0	0	INT				INTb					
1	1	0	0										
0	0	1	0										
1	0	1	0	INT						INTb			
0	1	1	0								INTb		
1	1	1	0	INTb	INT				INT				
0	0	0	1							INT	INTb		
1	0	0	1								INT		INT
0	1	0	1							INT			
1	1	0	1										
0	0	1	1		INTb			INT					
1	0	1	1	INT	INT			INT	INT	INT	INT		
0	1	1	1										
1	1	1	1										
PROG													

Exemplo 1 - Intercomunicador selectivo

num monitor com código de utilizador 1 e endereço de intercomunicação 1 programação P3 = intercomunicação selectiva ao endereço 2, P4 = intercomunicação selectiva ao endereço 3.

Exemplo 2 - Intercomunicador KIT (intercomunicação entre 2 endereços adjacentes no intervalo de 1 a 30, a começar por ímpar):

num monitor com código de utilizador 1 programação P3 = chamada geral interna, P4 = intercomunicação bifamiliar ao endereço 2.

1. Colocar os DIPs 5-6 de S2 na combinação 01.

» a luz indicadora (verde) pisca.

2. Consultar a tabela da pág. 115 e escolher uma combinação onde surja a função de intercomunicação (INT ou INTb) para os botões que se pretende programar.

EX. 1: para P3 = intercomunicação selectiva, configurar os DIPs 1-2-3-4 de S2 na combinação 1000 ou 0011 ou 1011 (P3 = INT), configurar S1 com o endereço 2 segundo a **tabela B** da pág. 114, passar ao ponto 3.

EX. 1: para P4 = intercomunicação selectiva, configurar os DIPs 1-2-3-4 de S2 na combinação 1110 ou 1011 (P4 = INT), configurar S1 com o endereço 3 segundo a **tabela B** da pág. 114, passar ao ponto 3.

EX. 2: para P3 = chamada geral interna e P4 = intercomunicação bifamiliar, configurar os DIPs 1-2-3-4 de S2 na combinação 1000 (P3 = INT, P4 = INTb), configurar S1 com o código de utilizador 1 segundo a **tabela A** da pág. 111, passar ao ponto 3.

3. Premir e libertar o botão ao qual se pretende associar a função.

» a luz indicadora (verde) acende-se.

» som de confirmação no auscultador.

4. Para sair da programação, colocar os DIPs 5-6 de S2 na combinação 00.

» a luz indicadora (verde) desliga-se.

5. No final da programação, colocar os DIPs 1-2-3-4 de S2 na combinação 1111. Repor em S1 a configuração do código de utilizador, consultar a **tabela A** da pág. 111.

Programação dos botões para outras funções

DIP S2				com Art. 6433, 6434				DIP S1					
DIP 1	DIP 2	DIP 3	DIP 4	P1	P2			P3	P4	P5	P6	PROG	
0	0	0	0	CCS	AI				D	PAN	K		
1	0	0	0		AI					D	CCS		
0	1	0	0		AI					CCS	CCP		
1	1	0	0		CCS			CCP	PAN	K	D		
0	0	1	0										
1	0	1	0										
0	1	1	0	AI	D			CCS	CCP		PAN		
1	1	1	0					K	CCS		CCP		
0	0	0	1	CCS	PAN			AI			D		
1	0	0	1	K	CCS			PAN	CCP	AI			
0	1	0	1	CCP	K			PAN			AI		
1	1	0	1	PAN	CCP			CCS	K		D		
0	0	1	1	D						AI	CCS		
1	0	1	1										
0	1	1	1	NULL	NULL	NULL	NULL	NULL	NULL	NULL	NULL		NULL
PROG													

Legenda

	Abertura da porta	CCS	Chamada à central	NULL	Nenhuma função
	Áudio	K	Chamada ao telefone intercomunicador do vigilante	PROG	Funções programadas
AI	Acendimento automático	D	Médico		
CCP	Chamada à central principal	PAN	Pânico		

Exemplo:

num monitor com código de utilizador 5 programação P5 = acendimento automático, P6 = chamada à central.

1. Colocar os DIPs 5-6 de S2 na combinação 01.

» a luz indicadora (verde) pisca.

2. Consultar a tabela da pág. 115 e escolher uma combinação onde surjam as funções desejadas/necessárias para os botões que se pretende programar.

EX.: para P5 = acendimento automático P6 = chamada à central configurar os DIPs 1-2-3-4 de S2 na combinação 0011 (P5 = AI, P6 = CCS).

3. Premir e libertar o botão ao qual se pretende associar a função.

» a luz indicadora (verde) acende-se.

» som de confirmação no auscultador.

4. Para sair da programação, colocar os DIPs 5-6 de S2 na combinação 00.

» a luz indicadora (verde) desliga-se.

5. No final da programação, colocar os DIPs 1-2-3-4 de S2 na combinação 1111.

TAB. C Endereços da coluna

Cod.	Dip switch ON	Cod.	Dip switch ON	Cod.	Dip switch ON	Cod.	Dip switch ON	Cod.	Dip switch ON	Cod.	Dip switch ON	Cod.	Dip switch ON	Cod.	Dip switch ON
1	1	31	1,2,3,4,5	61	1,3,4,5,6	91	1,2,4,5,7	121	1,4,5,6,7	151	1,2,3,5,8	181	1,3,5,6,8	211	1,2,5,7,8
2	2	32	6	62	2,3,4,5,6	92	3,4,5,7	122	2,4,5,6,7	152	4,5,8	182	2,3,5,6,8	212	3,5,7,8
3	1,2	33	1,6	63	1,2,3,4,5,6	93	1,3,4,5,7	123	1,2,4,5,6,7	153	1,4,5,8	183	1,2,3,5,6,8	213	1,3,5,7,8
4	3	34	2,6	64	7	94	2,3,4,5,7	124	3,4,5,6,7	154	2,4,5,8	184	4,5,6,8	214	2,3,5,7,8
5	1,3	35	1,2,6	65	1,7	95	1,2,3,4,5,7	125	1,3,4,5,6,7	155	1,2,4,5,8	185	1,4,5,6,8	215	1,2,3,5,7,8
6	2,3	36	3,6	66	2,7	96	6,7	126	2,3,4,5,6,7	156	3,4,5,8	186	2,4,5,6,8	216	4,5,7,8
7	1,2,3	37	1,3,6	67	1,2,7	97	1,6,7	127	1,2,3,4,5,6,7	157	1,3,4,5,8	187	1,2,4,5,6,8	217	1,4,5,7,8
8	4	38	2,3,6	68	3,7	98	2,6,7	128	8	158	2,3,4,5,8	188	3,4,5,6,8	218	2,4,5,7,8
9	1,4	39	1,2,3,6	69	1,3,7	99	1,2,6,7	129	1,8	159	1,2,3,4,5,8	189	1,3,4,5,6,8	219	1,2,4,5,7,8
10	2,4	40	4,6	70	2,3,7	100	3,6,7	130	2,8	160	6,8	190	2,3,4,5,6,8	220	3,4,5,7,8
11	1,2,4	41	1,4,6	71	1,2,3,7	101	1,3,6,7	131	1,2,8	161	1,6,8	191	1,2,3,4,5,6,8	221	1,3,4,5,7,8
12	3,4	42	2,4,6	72	4,7	102	2,3,6,7	132	3,8	162	2,6,8	192	7,8	222	2,3,4,5,7,8
13	1,3,4	43	1,2,4,6	73	1,4,7	103	1,2,3,6,7	133	1,3,8	163	1,2,6,8	193	1,7,8	223	1,2,3,4,5,7,8
14	2,3,4	44	3,4,6	74	2,4,7	104	4,6,7	134	2,3,8	164	3,6,8	194	2,7,8	224	6,7,8
15	1,2,3,4	45	1,3,4,6	75	1,2,4,7	105	1,4,6,7	135	1,2,3,8	165	1,3,6,8	195	1,2,7,8	225	1,6,7,8
16	5	46	2,3,4,6	76	3,4,7	106	2,4,6,7	136	4,8	166	2,3,6,8	196	3,7,8	226	2,6,7,8
17	1,5	47	1,2,3,4,6	77	1,3,4,7	107	1,2,4,6,7	137	1,4,8	167	1,2,3,6,8	197	1,3,7,8	227	1,2,6,7,8
18	2,5	48	5,6	78	2,3,4,7	108	3,4,6,7	138	2,4,8	168	4,6,8	198	2,3,7,8	228	3,6,7,8
19	1,2,5	49	1,5,6	79	1,2,3,4,7	109	1,3,4,6,7	139	1,2,4,8	169	1,4,6,8	199	1,2,3,7,8	229	1,3,6,7,8
20	3,5	50	2,5,6	80	5,7	110	2,3,4,6,7	140	3,4,8	170	2,4,6,8	200	4,7,8	230	2,3,6,7,8
21	1,3,5	51	1,2,5,6	81	1,5,7	111	1,2,3,4,6,7	141	1,3,4,8	171	1,2,4,6,8	201	1,4,7,8	231	1,2,3,6,7,8
22	2,3,5	52	3,5,6	82	2,5,7	112	5,6,7	142	2,3,4,8	172	3,4,6,8	202	2,4,7,8	232	4,6,7,8
23	1,2,3,5	53	1,3,5,6	83	1,2,5,7	113	1,5,6,7	143	1,2,3,4,8	173	1,3,4,6,8	203	1,2,4,7,8	233	1,4,6,7,8
24	4,5	54	2,3,5,6	84	3,5,7	114	2,5,6,7	144	5,8	174	2,3,4,6,8	204	3,4,7,8	234	2,4,6,7,8
25	1,4,5	55	1,2,3,5,6	85	1,3,5,7	115	1,2,5,6,7	145	1,5,8	175	1,2,3,4,6,8	205	1,3,4,7,8	235	1,2,4,6,7,8
26	2,4,5	56	4,5,6	86	2,3,5,7	116	3,5,6,7	146	2,5,8	176	5,6,8	206	2,3,4,7,8	236	3,4,6,7,8
27	1,2,4,5	57	1,4,5,6	87	1,2,3,5,7	117	1,3,5,6,7	147	1,2,5,8	177	1,5,6,8	207	1,2,3,4,7,8	237	1,3,4,6,7,8
28	3,4,5	58	2,4,5,6	88	4,5,7	118	2,3,5,6,7	148	3,5,8	178	2,5,6,8	208	5,7,8	238	2,3,4,6,7,8
29	1,3,4,5	59	1,2,4,5,6	89	1,4,5,7	119	1,2,3,5,6,7	149	1,3,5,8	179	1,2,5,6,8	209	1,5,7,8	239	1,2,3,4,6,7,8
30	2,3,4,5	60	3,4,5,6	90	2,4,5,7	120	4,5,6,7	150	2,3,5,8	180	3,5,6,8	210	2,5,7,8	*240	5,6,7,8

*NOTA: o código 240 está reservado para a central de portaria







PT

Reinicialização da programação

! 1)		! 2)						3)		4)
S1	DIP 1	DIP 2	DIP 3	DIP 4	DIP 5	DIP 6	S2			S1/S2/LED1
<p>DIP ON</p>	1	1	1	1	1	1		<p>5 sec</p>	<p>2 sec</p>	<p>Tomar nota da configuração de S2, S1 e repor no final da programação</p>
<p>Configurações de fábrica:</p> <ul style="list-style-type: none"> • Funções dos botões em função da combinação dos DIPs 1-2-3-4 de S2; • Endereço de intercomunicação ausente; • Função intervalo e endereços mín. e máx. permitidos; • Reinício campanhas • Entrada IN 1 ⇒ Luz indicadora (predefinida). 										

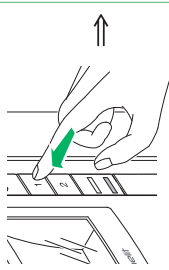
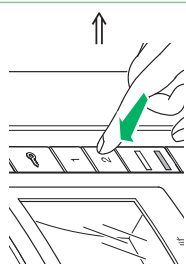
Realizar as operações de 1 a 4

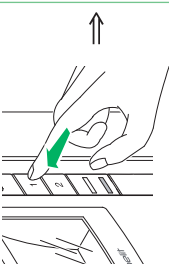
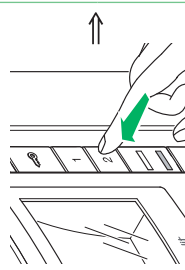
Programação range/campainhas	1)		2)						3)		4)
	S1	S2	DIP 1	DIP 2	DIP 3	DIP 4	DIP 5	DIP 6	S1/S2/LED1		
Endereço mínimo intervalo											<p>Tomar nota da configuração de S2, S1 e repor no final da programação</p>
Endereço máximo intervalo	configurara código, TAB. C na pág. 116		0	0	0	0	1	0			
Activação intervalo											<p>2 sec</p>
Desactivação intervalo											
Seleção de campainha polifónica											
Seleção de campainha sons (predefinida)			0	1	0	1	1	0			

Realizar as operações de 1 a 4											
1)		2)						3)		4)	
S1		DIP 1	DIP 2	DIP 3	DIP 4	DIP 5	DIP 6	S2		S1/S2/LED1	
Programação da entrada IN1 para indicação luz indicador/alarme/abertura da porta/actuador											
Entrada IN 1 ⇒ Luz indicadora (predefinida), consultar as página 138											
Entrada IN 1 ⇒ ALARME, consultar as página 138		0	0	0	1	1	0				
Entrada IN 1 ⇒ ABERTURA DA PORTA, consultar as página 138											
Entrada IN 1 ⇒ ACTUADOR COM ENDEREÇO, consultar as página 138											
Entrada IN 1 ⇒ ACTUADOR GENÉRICO, consultar as página 138											

Tomar nota da configuração de S2, S1 e repor no final da programação

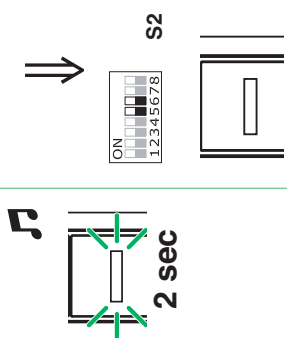

Programação directa da chamada de intercomunicação

Permite a programação das chamadas de intercomunicação directamente dos postos internos.

✓ Requer 2 operadores.

Fase 1: entrada em programação

Operador 1 e operador 2 realizam as seguintes operações nos 2 postos internos:

1. Configurar os DIPs 1-2-3-4 de S2 na combinação 1111.
2. Levantar o auscultador.
3. Premir a tecla 1 e 2 por 3 seg.
4. *O posto interno emite 1 som.*
» *A luz indicadora verde pisca.*
» *O posto interno entra em comunicação.*
» *Neste momento os 2 operadores estão em comunicação entre si.*

Fase 2: programação da chamada de intercomunicação

Operador 1:

- ▶ Premir o botão que pretende programar para chamar o operador 2 (ex.: 2).
- » *O posto interno do operador 1 emite um som de confirmação.*

Operador 2:

- ▶ Premir o botão que pretende programar para chamar o operador 1 (ex.: 1).
- » *O posto interno do operador 2 emite um som de confirmação.*

Operador 1/Operador 2:

- ▶ Desligar o aparelho.
 - » *O posto interno emite 1 som.*
» *A programação dos 2 postos internos está assim concluída.*
- Para programar outro posto interno, passar à Fase 3.



Fase 3: programar outros postos internos

Operador 1/Operador 2:

1. Ao chegar à nova posição realizar a fase 1 para entrar em comunicação.
2. Repetir a fase 2.

NOTA Caso se receba uma chamada durante a programação, é necessário responder à chamada e posteriormente retomar a fase de programação.

Variante das campanhas do monitor

1. Manter premido o botão  até que seja emitido um som de confirmação (a operação é possível apenas nos aparelhos em situação de repouso; caso contrário a luz indicadora piscará para avisar o utilizador).
2. Premir e libertar o botão  :
1 vez é emitido um som de confirmação) para modificar a campanha de chamada do posto exterior.
2 vezes (são emitidos 2 sons de confirmação) para modificar a campanha de chamada da central.
3 vezes (são emitidos 3 sons de confirmação) para modificar a campanha da chamada de intercomunicação do posto interno.
4 vezes (são emitidos 4 sons de confirmação) para modificar a campanha de chamada do andar.
Ao premir o botão  novamente, repete a sequência descrita acima.
3. Premir e libertar o botão 1 para percorrer as várias campanhas disponíveis na sequência.
4. Premir o botão 2 para confirmar a selecção da última campanha ouvida e para sair (em qualquer altura) do modo de selecção do som da campanha do monitor. Ao sair do modo de selecção da campanha do monitor, será emitido um som de confirmação.

Programações especiais Art. 4680KC

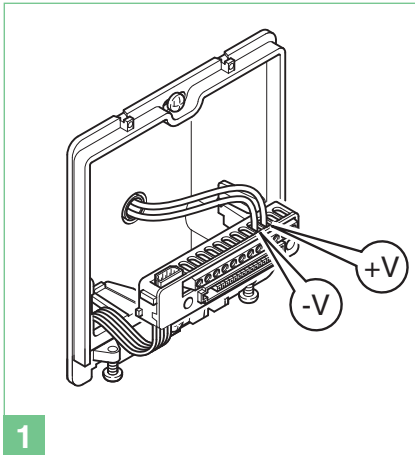

1

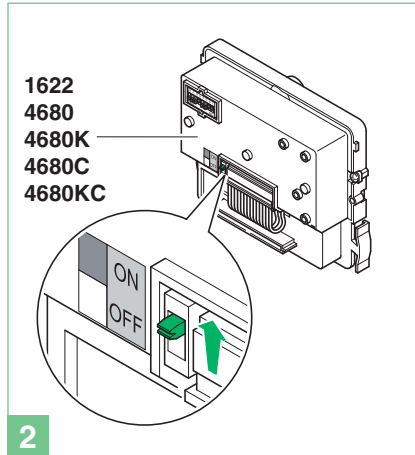

2

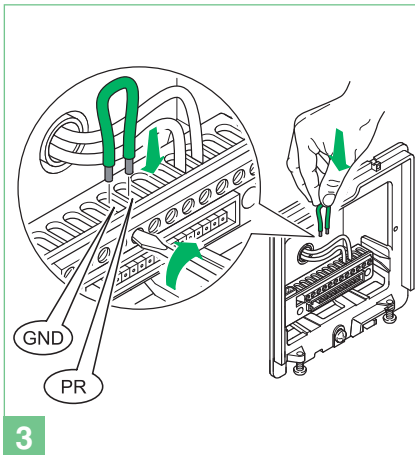

3

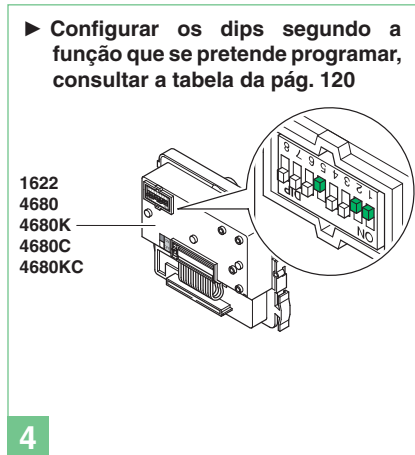

4

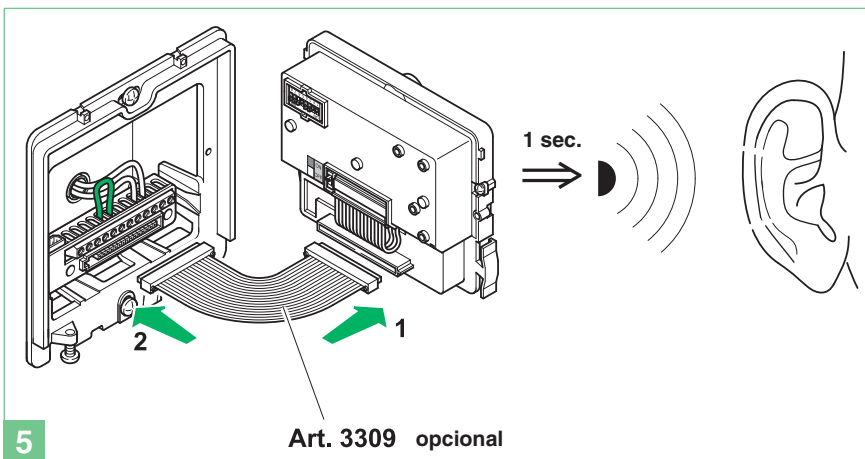

5

Art. 3309 opcional

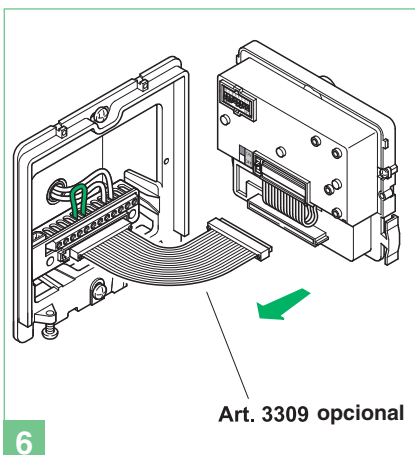

6

Art. 3309 opcional

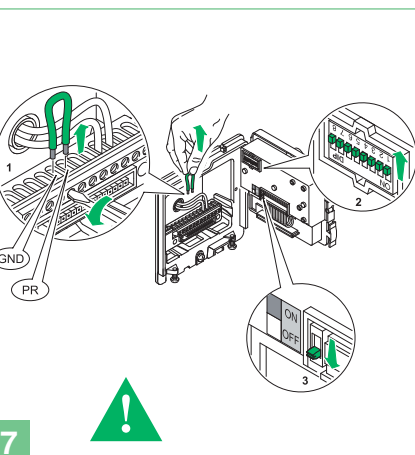

7

Código	Dip switch ON	
Resistência antiembaciamento		
213	1,3,5,7,8	OFF (predefinição)
212	3,5,7,8	ON

Mensagens audiovisuais		
210	2,5,7,8	apenas mensagens visuais
211	1,2,5,7,8	Sueco
214	2,3,5,7,8	OFF (predefinição)
215	1,2,3,5,7,8	Italiano
216	4,5,7,8	Francês
217	1,4,5,7,8	Espanhol
218	2,4,5,7,8	Holandês
219	1,2,4,5,7,8	Grego
220	3,4,5,7,8	Inglês
221	1,3,4,5,7,8	Alemão
222	2,3,4,5,7,8	Português

Fechadura		
223	1,2,3,4,5,7,8	Comando fechadura em SE para AC (predefinição)
224	6,7,8	Comando fechadura em SE para AC melhorada
225	1,6,7,8	Comando fechadura em SE para DC
245	1,3,5,6,7,8	Tempo fechadura: 2 seg. + som desactivado (predefinição)
246	2,3,5,6,7,8	Tempo fechadura: 4 seg.
247	1,2,3,5,6,7,8	Tempo fechadura: 8 seg.
248	4,5,6,7,8	Som de confirmação fechadura: activado
251	1,2,4,5,6,7,8	Relé C.NC.NO em paralelo a SE (predefinição)
252	3,4,5,6,7,8	Abertura da porta sempre activada (predefinição)
253	1,3,4,5,6,7,8	Abertura da porta activada apenas para o utilizador que recebe a chamada

Gestão do comando actuador		
NOTA: na instalação o Art. 1256 não deverá estar no modo de actuador geral.		
229	1,3,6,7,8	Activação do relé C.NC.NO no comando actuador: 2 seg.
230	2,3,6,7,8	Activação do relé C.NC.NO no comando actuador: 4 seg.
231	1,2,3,6,7,8	Activação do relé C.NC.NO no comando actuador: 8 seg.
228	3,6,7,8	Comando actuador na linha serial S: desactivado (predefinição)
227	1,2,6,7,8	Comando actuador na linha serial S: activado

Funções do equipamento		
232	4,6,7,8	Tempo de espera resposta: 60 seg. (predefinição)
233	1,4,6,7,8	Tempo de espera resposta: 120 seg.
234	2,4,6,7,8	Tempo de espera resposta: 30 seg.
235	1,2,4,6,7,8	Tempo de conversação: 90 seg. (predefinição)
236	3,4,6,7,8	Tempo de conversação: 180 seg.

237	1,3,4,6,7,8	Acendimento automático: activado (predefinição)
238	2,3,4,6,7,8	Acendimento automático: desactivado

239	1,2,3,4,6,7,8	Som de confirmação aquando da chamada de utilizador: activado (predefinição)
240	5,6,7,8	Som de confirmação aquando da chamada de utilizador: desactivado

243	1,2,5,6,7,8	Tempo de espera reiniciação: 10 seg. (predefinição)
244	3,5,6,7,8	Tempo de espera reiniciação: 1 seg.
208	5,7,8	Reiniciação após abertura de porta em áudio: activado (predefinição)
209	1,5,7,8	Reiniciação após abertura de porta em áudio: desactivado
249	1,4,5,6,7,8	Envio de chamada: única (predefinição)
250	2,4,5,6,7,8	Envio chamada: tripla

254	2,3,4,5,6,7,8	Reposição predefinição
-----	---------------	-------------------------------

PT

- IT** Schema base per kit bifamiliari Art. 8172IMC con collegamento in cascata. Messa in funzione/verifica tensioni di impianto a riposo.
- EN** Basic diagram for two-family kits Art. 8172IMC with cascade connection. Switching on/voltage check with system in standby.
- FR** Schéma base pour kit deux usagers Art. 8172IMC avec connexion en cascade. Mise en service/vérification tensions d'installation au repos.
- NL** Basisschema voor kits voor tweegezinswoningen Art. 8172IMC met aansluiting in cascade. Inwerkingstelling/spanningscontrole van een systeem in de ruststand.
- DE** Basisschema voor kits voor tweegezinswoningen Art. 8172IMC met aansluiting in cascade. Inbetriebnahme / Spannungsprüfung der Anlage im Standby-Modus.
- ES** Esquema básico para kits bifamiliares Art. 8172IMC con conexión en cascada. Puesta en funcionamiento/comprobación de las tensiones con la instalación en reposo.
- PT** Esquema básico para kits bifamiliares Art. 8172IMC com ligação em cascata. Colocação em funcionamento/controlo das tensões do aparelho quando está em repouso.

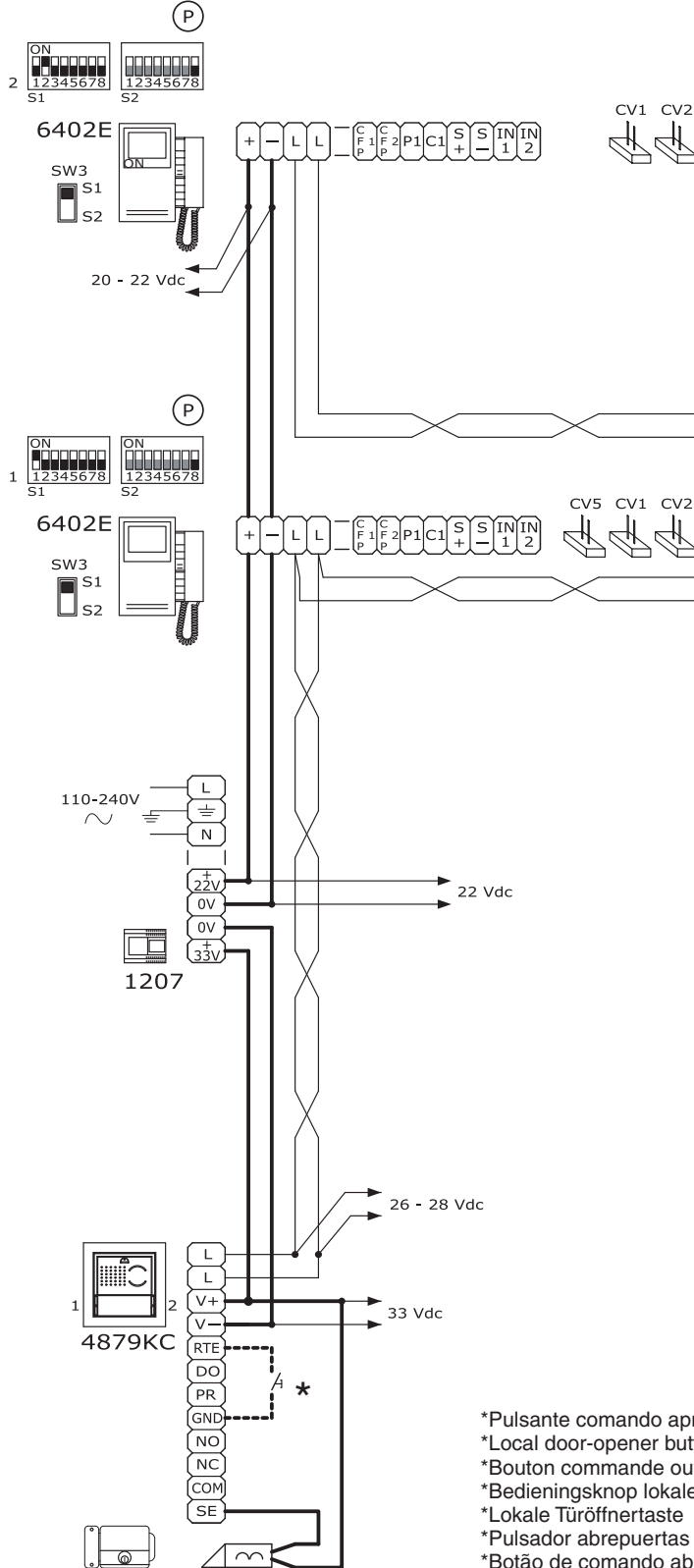

Per maggiori informazioni sulle distanze vedi pag. 8
 For further information about distances refer to page 25
 Pour plus de détails sur les distances faire référence au page 42
 Zie voor meer informatie over de afstanden pagina 59
 Siehe Seite 76 für weitere Informationen zu den Entfernungen
 Para mayor información sobre las distancias, véase la página 93
 Para mais informações sobre as distâncias, consultar as página 110

	A MAX	B MAX	C MAX
Comelit Art. 4576-4578 0,5 mm ² (Ø 0,8 mm AWG 20)		25 m (85 feet)	200 m (655 feet)
UTP5 cat. 5 0,2 mm ² (Ø 0,5 mm AWG 24)			190 m (625 feet)
0,28 mm ² (Ø 0,6 mm AWG 23)	5 m (15 feet)		190 m (625 feet)
0,5 mm ² (Ø 0,8 mm AWG 20)	25 m (85 feet)	25 m (85 feet)	190 m (625 feet)
1 mm ² (Ø 1,2 mm AWG 17)	50 m (165 feet)	50 m (165 feet)	190 m (625 feet)
1 mm ² (Ø 1,2 mm AWG 17)	50 m (165 feet)	50 m (165 feet)	120 m (395 feet)
1,5 mm ² (Ø 1,4 mm AWG 15)	75 m (245 feet)	100 m (330 feet)	190 m (625 feet)
2,5 mm ² (Ø 1,8 mm AWG 13)	100 m (330 feet)	150 m (495 feet)	190 m (625 feet)

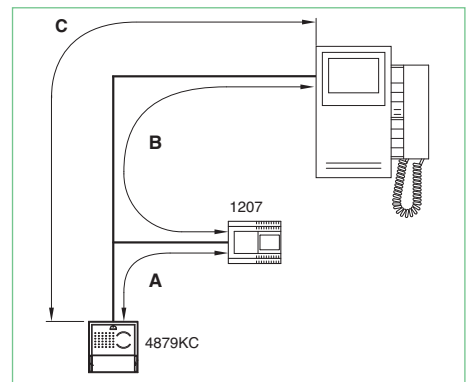

- * Pulsante comando apriporta locale
- * Local door-opener button
- * Bouton commande ouvre-porte local
- * Bedieningsknop lokale deuropener
- * Lokale Türöffnertaste
- * Pulsador abrepuertas local
- * Botão de comando abertura da porta local

MSK/013IBC

- IT** Schema base per kit bifamiliari Art. 8172IMC con collegamento in derivazione
- EN** Basic diagram for two-family kits Art. 8172IMC with branch connection
- FR** Schéma base pour kit deux usagers Art. 8172IMC avec connexion en dérivation
- NL** Basisschema voor kits voor tweegezinswoningen Art. 8172IMC met afgetakte aansluiting
- DE** Grundanschlussplan für Zweifamilienhaus-Sets Art. 8172IMC mit Anschluss über Abzweigung
- ES** Esquema básico para kit bifamiliares Art. 8172IMC con conexión en derivación
- PT** Esquema base para kits bifamiliares Art. 8172IMC com ligação em derivação

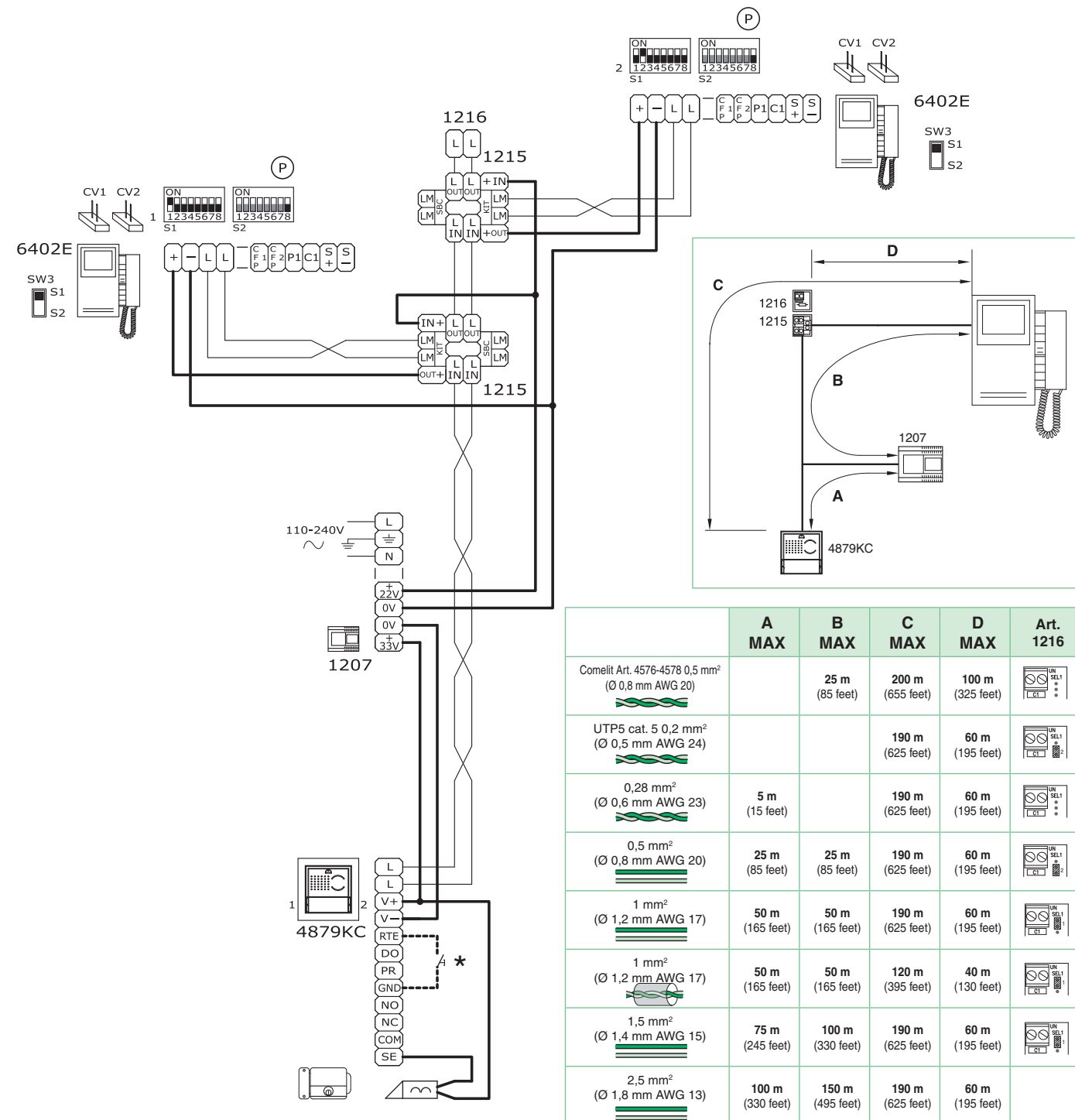

- *Pulsante comando apriporta locale
- *Local door-opener button
- *Bouton commande ouvre-porte local
- *Bedieningsknop lokale deurpener
- *Lokale Türöffnertaste
- *Pulsador abrepuertas local
- *Botão de comando abertura da porta local

Per maggiori informazioni sulle distanze vedi pag. 8
 For further information about distances refer to page 25
 Pour plus de détails sur les distances faire référence au page 42
 Zie voor meer informatie over de afstanden pagina 59
 Siehe Seite 76 für weitere Informationen zu den Entfernungen
 Para mayor información sobre las distancias, véase la página 93
 Para mais informações sobre as distâncias, consultar as página 110

- (IT) Schema per kit bifamiliari Art. 8172IMC ampliati con un secondo Art. 4879KC. Collegamento in derivazione.
- (EN) Diagram for two-family kits Art. 8172IMC extended with a second Art. 4879KC. Branch connection.
- (FR) Schéma pour kit deux usagers Art. 8172IMC complétés avec un second Art. 4879KC. Connexion en dérivation.
- (NL) Schema voor kits voor tweegezinswoningen Art. 8172IMC uitgebreid met een tweede entreepaneel Art. 4879KC. Afgetakte aansluiting.
- (DE) Anschlussplan für Zweifamilienhaus-Sets Art. 8172IMC, erweitert um einen zweiten Art. 4879KC. Anschluss über Abzweigung.
- (ES) Esquema para kits bifamiliares Art. 8172IMC ampliados con un segundo Art. 4879KC. Conexión en derivación.
- (PT) Esquema para kits bifamiliares Art. 8172IMC ampliados com um segundo Art. 4879KC. Ligaçao em derivação.

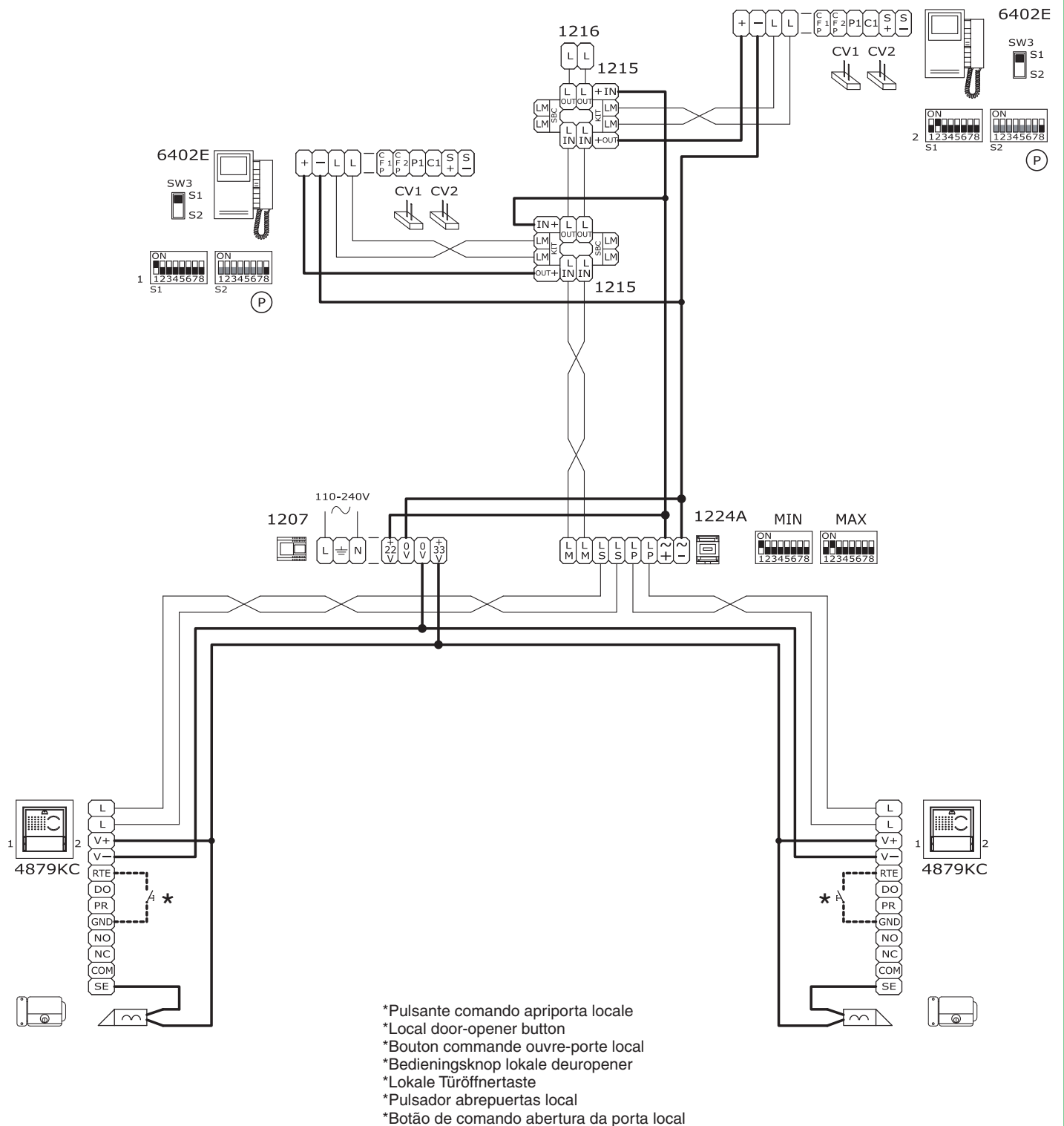

MSK/014IAC

- (IT) Schema per kit bifamiliari Art. 8172IMC ampliati con un secondo Art. 4879KC. Collegamento in cascata.
- (EN) Diagram for two-family kits Art. 8172IMC extended with a second Art. 4879KC. Cascade connection.
- (FR) Schéma pour kit deux usagers Art. 8172IMC complétés avec un second Art. 4879KC. Connexion en cascade.
- (NL) Schema voor kits voor tweegezinswoningen Art. 8172IMC uitgebreid met een tweede entreepaneel Art. 4879KC. Anschluss in Kaskadenschaltung.
- (DE) Anschlussplan für Zweifamilienhaus-Sets Art. 8172IMC, erweitert um einen zweiten Art. 4879KC. Anschluss in Kaskadenschaltung.
- (ES) Esquema para kits bifamiliares Art. 8172IMC ampliados con un segundo Art. 4879KC. Conexión en cascada.
- (PT) Esquema para kits bifamiliares Art. 8172IMC ampliados com um segundo Art. 4879KC. Ligação em cascata.

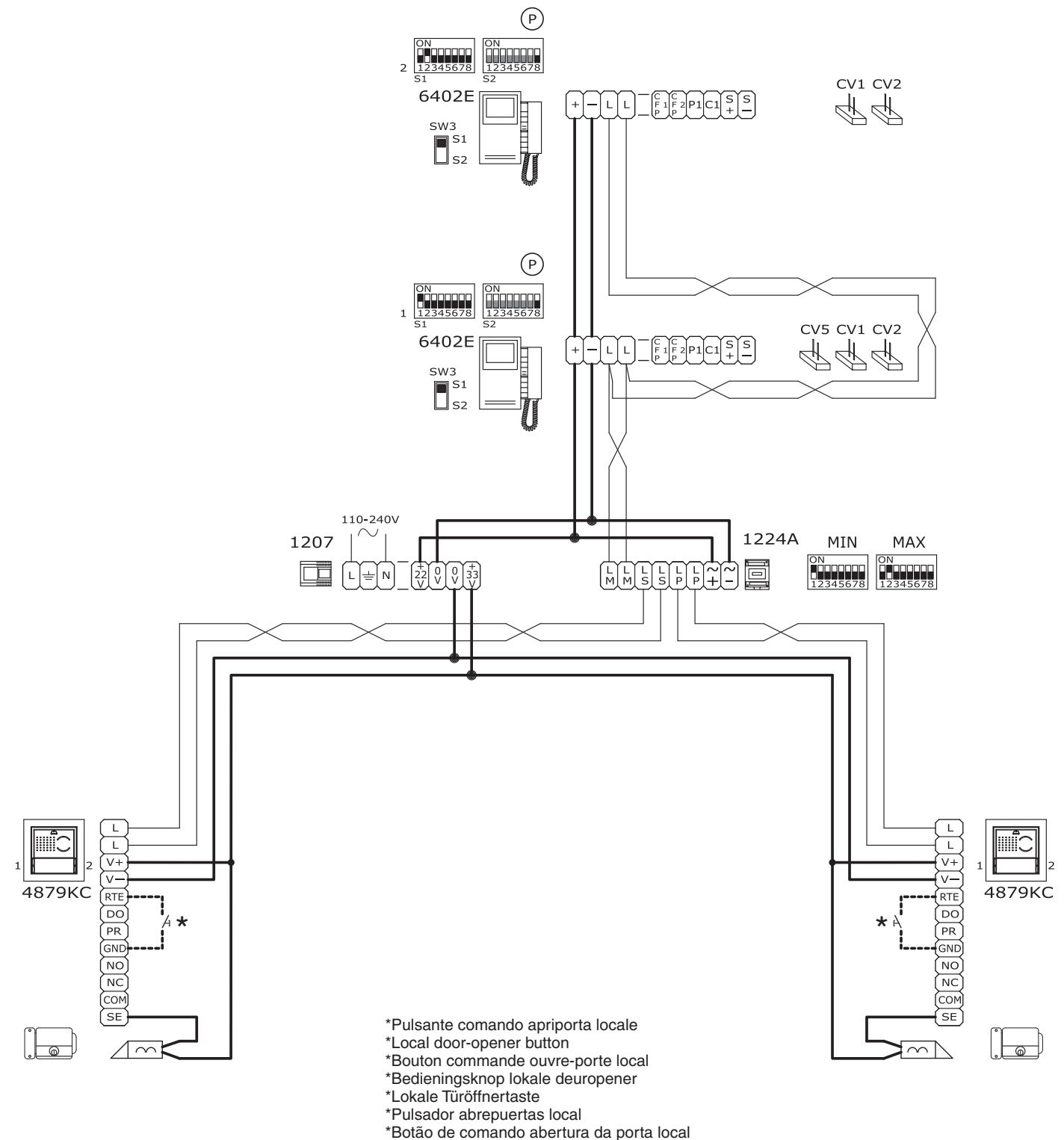

- (IT) Schema per kit bifamiliare con alimentatore aggiuntivo Art. 1595
 (EN) Diagram for two-family kit with additional power supply unit Art. 1595
 (FR) Schéma pour kit deux usager avec alimentateur complémentaire Art. 1595
 (NL) Schema voor kit voor tweegezinswoning met extra voedingstransformator Art. 1595
 (DE) Schaltplan für Zweifamilienhaus mit zusätzlichem Netzteil Art. 1595
 (ES) Esquema para kits bifamiliares con alimentador adicional Art. 1595
 (PT) Esquema para kit bifamiliares com alimentador suplementar Art.1595

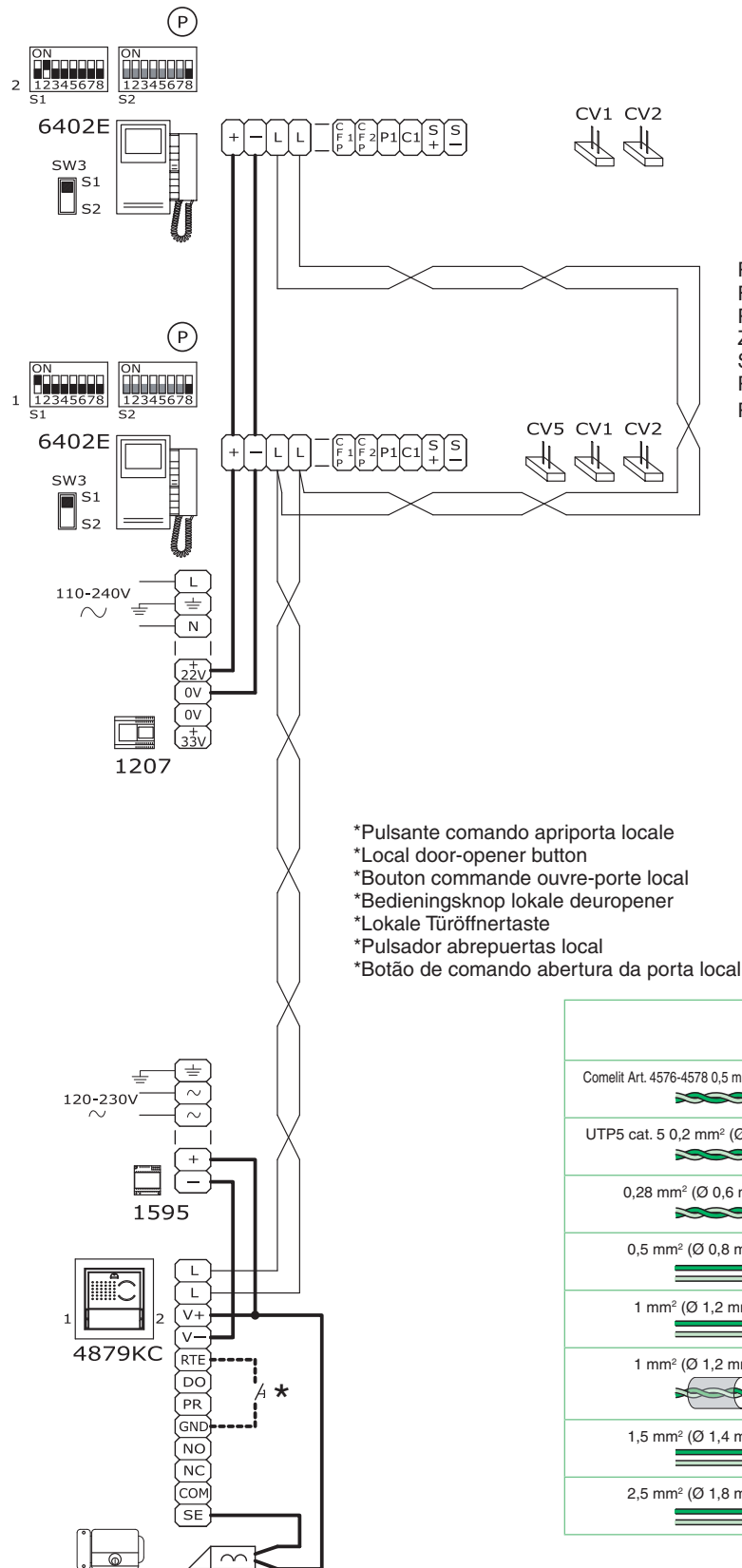

Per maggiori informazioni sulle distanze vedi pag. 8
 For further information about distances refer to page 25
 Pour plus de détails sur les distances faire référence au page 42
 Zie voor meer informatie over de afstanden pagina 59
 Siehe Seite 76 für weitere Informationen zu den Entfernungen
 Para mayor información sobre las distancias, véase la página 93
 Para mais informações sobre as distâncias, consultar as página 110

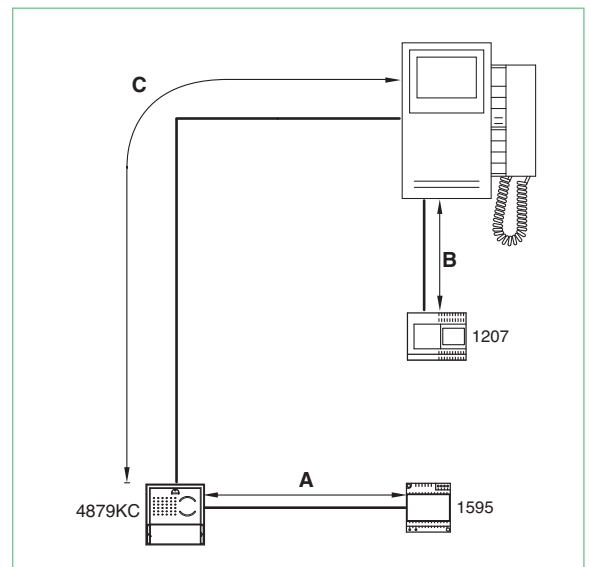

	A MAX	B MAX	C MAX	C MAX (Art. 4833C)
Cornelit Art. 4576-4578 0,5 mm ² (Ø 0,8 mm AWG 20)		25 m (85 feet)	200 m (655 feet)	300 m (990 feet)
UTP5 cat. 5 0,2 mm ² (Ø 0,5 mm AWG 24)			190 m (625 feet)	300 m (990 feet)
0,28 mm ² (Ø 0,6 mm AWG 23)	5 m (15 feet)		190 m (625 feet)	300 m (990 feet)
0,5 mm ² (Ø 0,8 mm AWG 20)	25 m (85 feet)	25 m (85 feet)	190 m (625 feet)	300 m (990 feet)
1 mm ² (Ø 1,2 mm AWG 17)	50 m (165 feet)	50 m (165 feet)	190 m (625 feet)	300 m (990 feet)
1 mm ² (Ø 1,2 mm AWG 17)	50 m (165 feet)	50 m (165 feet)	120 m (395 feet)	200 m (660 feet)
1,5 mm ² (Ø 1,4 mm AWG 15)	75 m (245 feet)	100 m (330 feet)	190 m (625 feet)	300 m (990 feet)
2,5 mm ² (Ø 1,8 mm AWG 13)	100 m (330 feet)	150 m (495 feet)	190 m (625 feet)	300 m (990 feet)

MSK/019IC

- IT Utilizzo modulo telecamera scorporata Art. 1259C
- EN Use of remote camera module Art. 1259C
- FR Emploi module caméra déportée Art. 1259C
- NL Gebruik module voor externe camera Art. 1259C

- DE Einsatz des separaten Kameramoduls Art. 1259C
- ES Uso del módulo telecámara separada Art. 1259C
- PT Utilização do módulo da câmara separada Art. 1259C

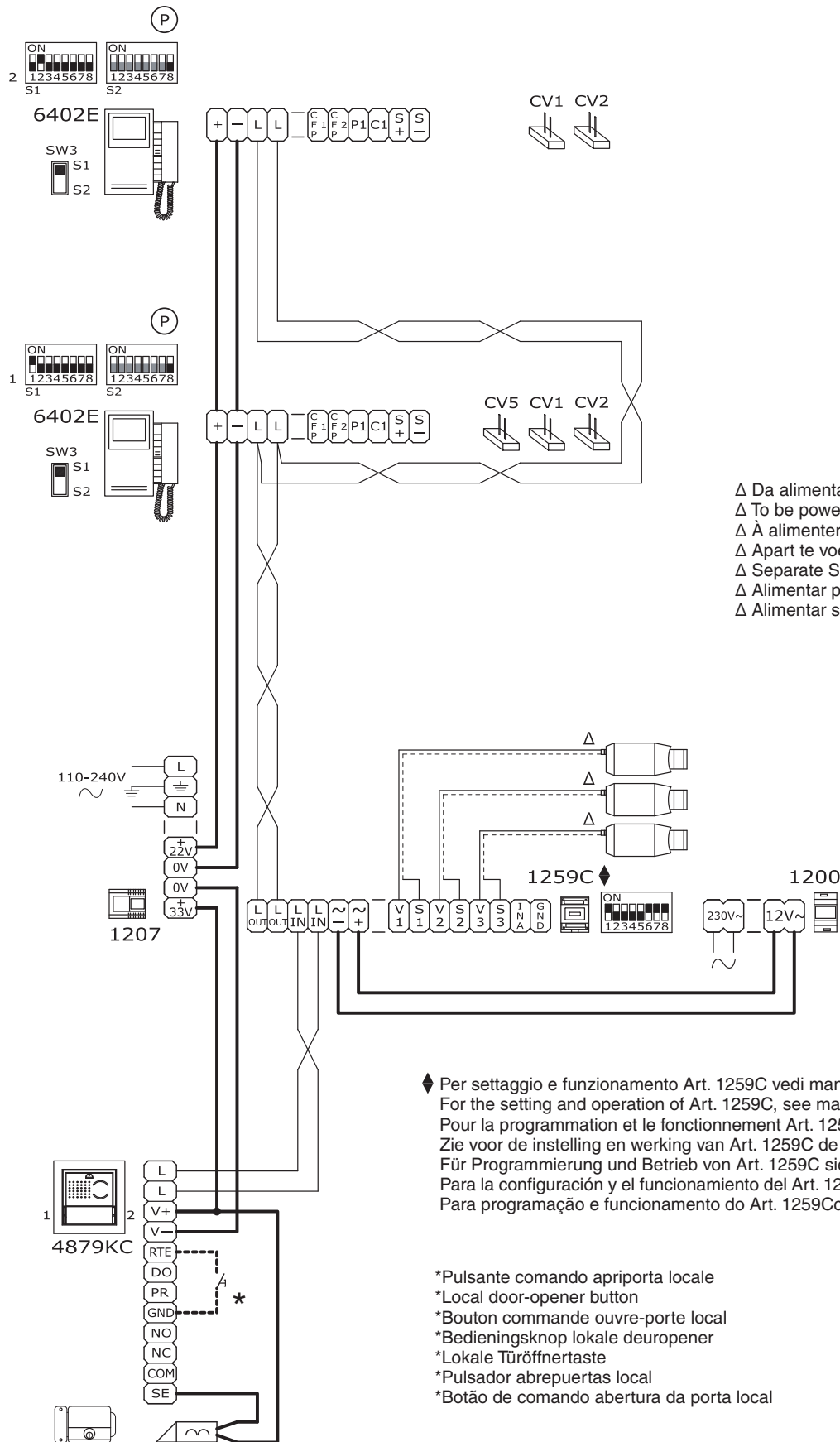

Δ Da alimentare separatamente
 Δ To be powered separately
 Δ À alimenter séparément
 Δ Apart te voeden
 Δ Separate Stromversorgung erforderlich
 Δ Alimentar por separado
 Δ Alimentar separadamente

◆ Per settaggio e funzionamento Art. 1259C vedi manuale cod. 2G40000690
 For the setting and operation of Art. 1259C, see manual cod. 2G40000690
 Pour la programmation et le fonctionnement Art. 1259C voir manuel cod. 2G40000690
 Zie voor de instelling en werking van Art. 1259C de handleiding cod. 2G40000690
 Für Programmierung und Betrieb von Art. 1259C siehe cod. 2G40000690
 Para la configuración y el funcionamiento del Art. 1259C véase manual cod. 2G40000690
 Para programação e funcionamento do Art. 1259C consultar manual cod. 2G40000690

- *Pulsante comando apriporta locale
- *Local door-opener button
- *Bouton commande ouvre-porte local
- *Bedieningsknop lokale deuropener
- *Lokale Türöffnertaste
- *Pulsador abrepuertas local
- *Botão de comando abertura da porta local

- IT Collegamento relé attuatore Art. 1256
- EN Connecting actuator relay Art. 1256
- FR Branchement relais actionneur Art.1256
- NL Aansluiting relais module Art. 1256

- DE Anschluss Relais Art. 1256
- ES Conexión del relé actuador Art. 1256
- PT Ligação do relé actuador Art. 1256

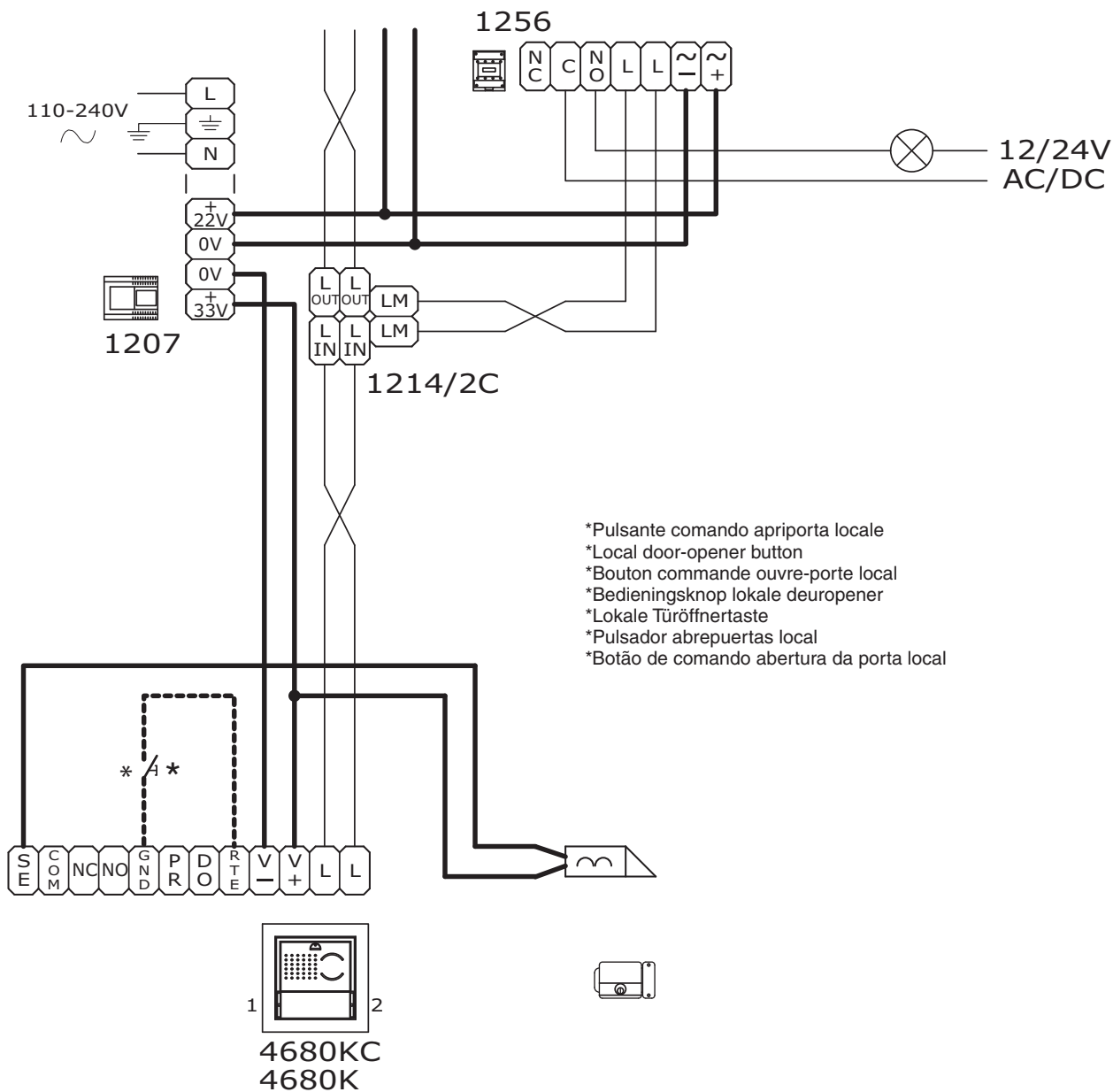

- *Pulsante comando apriporta locale
- *Local door-opener button
- *Bouton commande ouvre-porte local
- *Bedieningsknop lokale deuropener
- *Lokale Türöffnertaste
- *Pulsador abrepuertas local
- *Botão de comando abertura da porta local

- IT Non alimentare l'Art. 1256 con 33v in continua.
In caso di bisogno aggiungere l'Art. 1200.
Per maggiori informazioni su Art. 1256 vedi manuale tecnico cod. 2G40000687
- EN Do not power Art. 1256 with continuous 33 V supply.
If necessary, add Art. 1200.
For further information on Art. 1256, see technical manual cod. 2G40000687
- FR Ne pas alimenter l'Art. 1256 avec 33v en continu.
En cas de besoin ajouter l'Art. 1200.
Pour plus d'informations sur l'Art.1256 voir manuel technique cod. 2G40000687
- NL Voed Art. 1256 niet met 33v continuustroom
Indien nodig Art. 1200 toevoegen.
Zie voor meer informatie over Art. 1256, technische handleiding cod. 2G40000687

- DE Den Art. 1256 nicht mit 33V Gleichspannung versorgen.
Im Bedarfsfall den Art. 1200 hinzufügen.
Für weitere Informationen über Art. 1256 siehe technisches handbuch cod. 2G40000687
- ES No alimentar el Art. 1256 con 33 V en corriente continua
Si es necesario, añadir el Art. 1200.
Para mayor información sobre el Art. 1256, véase manual técnico cod. 2G40000687
- PT Não alimentar o Art. 1256 com 33 V em continuação.
Em caso de necessidade adicionar o Art. 1200.
Para mais informações sobre o Art. 1256, consultar manual técnico cod. 2G40000687

- (IT) Schema per connessione a porta principale da 2 a 9 Magis Kit tramite Art. 4834/9
- (EN) Diagram for connecting 2 to 9 Magis Kits to main entrance panel using Art. 4834/9
- (FR) Schéma pour connexion à porte principale de 2 à 9 Magis kit avec Art. 4834/9
- (NL) Schema voor aansluiting op hoofdingang van 2 tot 9 Magis Kits met Art. 4834/9

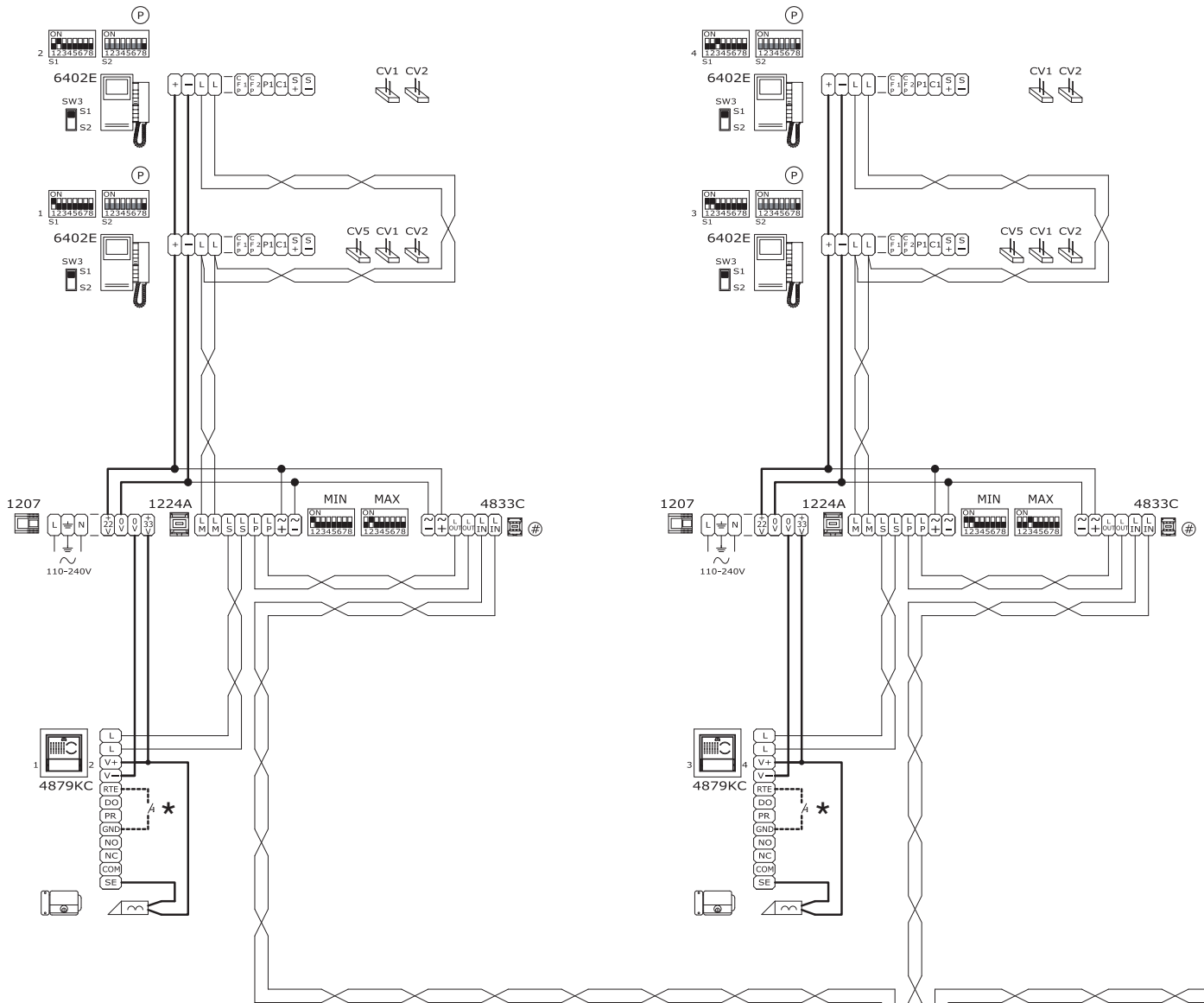

- ◆ (IT) **Limitazioni utilizzo Art. 4680KC.** Il 4680KC gestisce le chiamate provenienti dai moduli pulsanti o digitali **SOLO** se comprese tra l'indirizzo 1 e l'indirizzo 10.
- (EN) **Operating restrictions for Art. 4680KC.** Art. 4680KC manages calls originating from **ONLY** digital or button modules if they fall between address and address 10.
- (FR) **Limitations utilisation Art. 4680KC.** L'Art. 4680KC gère les appels provenant des modules à boutons ou numériques, **UNIQUEMENT** s'ils sont compris entre l'adresse 1 et l'adresse 10.
- (NL) **Gebruiksbeperkingen Art. 4680KC.** De 4680KC beheert de oproepen die afkomstig zijn van de drukknopmodulen of digitale modulen **ALLEEN** als ze zich tussen het adres 1 en het adres 10 bevinden.
- (DE) **Verwendungseinschränkungen Art. 4680KC.** Der Art. 4680KC verwaltet die von den Tasten- oder digitalen Rufmodulen eingehenden Anrufe **NUR**, wenn sie zwischen der Adresse 1 und der Adresse 10 liegen.
- (ES) **Limites de uso del Art. 4680KC.** El Art. 4680KC gestiona las llamadas procedentes de los módulos de pulsadores o digitales **SÓLO** si están comprendidas entre la dirección 1 y la dirección 10.
- (PT) **Limitações de utilização do Art. 4680KC.** O Art. 4680KC gere as chamadas provenientes dos módulos de botões ou digitais **APENAS** se estiver entre o endereço 1 e o endereço 10.

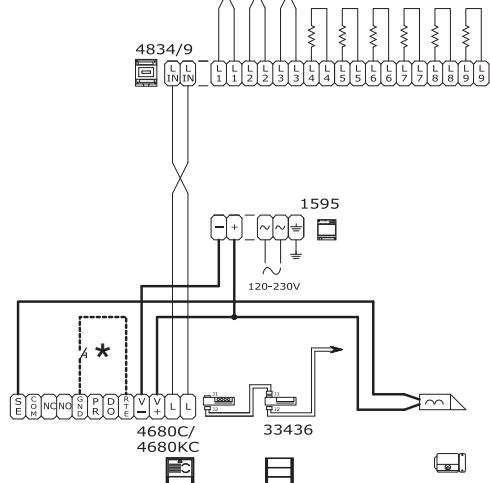

DE Plan für den Anschluss von 2 bis 9 Magis Kit an die Haupttür über Art. 4834/9

ES Esquema para conectar a la puerta principal de dos a nueve Magis Kit mediante el Art. 4834/9

PT Esquema para a ligação com a porta principal de 2 a 9 Magis Kits através do Art. 4834/9

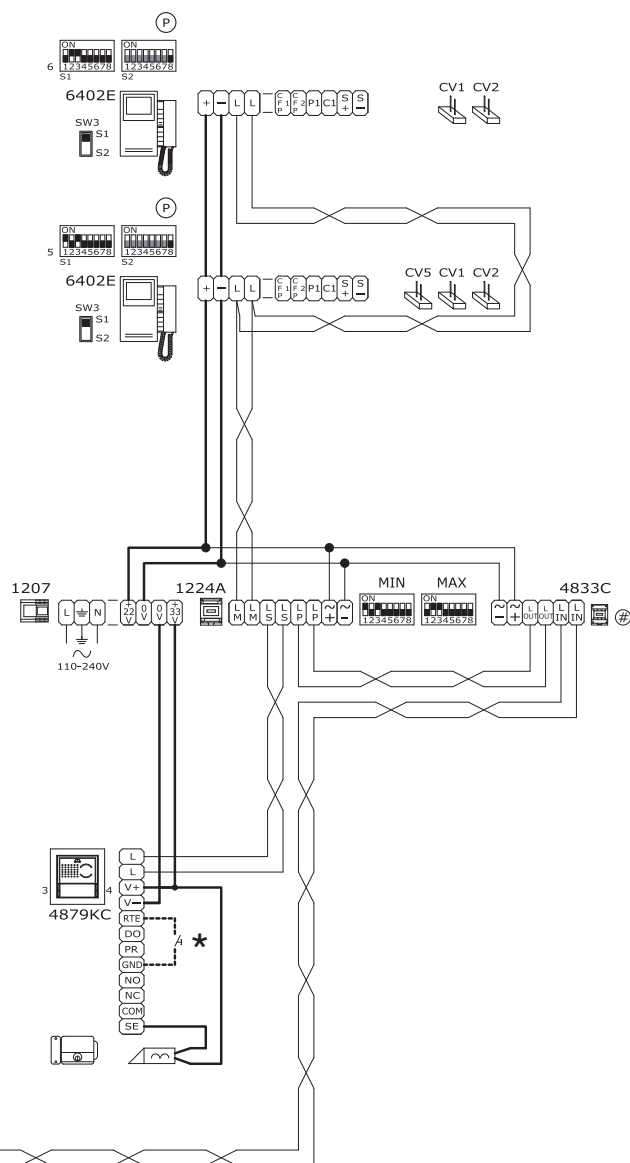

- *Pulsante comando apriporta locale
- *Local door-opener button
- *Bouton commande ouvre-porte local
- *Bedieningsknop lokale deur opener
- *Lokale Türöffnertaste
- *Pulsador abrepuertas local
- *Botão de comando abertura da porta local

(IT) Per maggiori informazioni sulle distanze di utilizzo dell'Art. 4833C e Art. 4834/9 e per maggiori informazioni sulle impostazioni necessarie in merito all'Art. 1224A fare riferimento al manuale tecnico cod. 2G40000472.

(EN) For further information on operating distances for Art. 4833C and Art. 4834/9, and for further information on the necessary settings for Art. 1224A, refer to the technical manual cod. 2G40000472.

(FR) Pour plus d'informations sur les distances d'utilisation de l'Art. 4833C et Art. 4834/9 et plus de détails sur les réglages nécessaires en ce qui concerne l'Art. 1224A se référer au manuel technique cod. 2G40000472.

(NL) Zie voor meer informatie over de gebruiksaftstanden van Art. 4833C en Art. 4834/9 en voor meer informatie over de benodigde instellingen voor Art. 1224A de technische handleiding cod. 2G40000472.

(DE) Weitere Informationen über die Entfernungen zur Verwendung von Art. 4833C und Art. 4834/9 sowie über die für Art. 1224A erforderlichen Einstellungen sind dem technischen cod. 2G40000472. Handbuch zu entnehmen

(ES) Para mayor información sobre las distancias de uso del Art. 4833C y del Art. 4834/9 y sobre la configuración necesaria para el Art. 1224A, consultar el manual técnico cod. 2G40000472.

(PT) Para mais informações sobre as distâncias de utilização do Art. 4833C e Art. 4834/9 e para mais informações sobre as programações necessárias em relação ao Art. 1224A, consultar o manual técnico cod. 2G40000472.

- (IT) Schema per connessione a porta principale di 30 Magis Kit (massimo). Collegamento Magis in cascata con Art. 1424.
- (EN) Diagram for connecting 30 Magis Kits (maximum) to the main entrance panel. Cascade connection of Magis using Art. 1424.
- (FR) Schéma pour connexion à porte principale de 30 Magis Kit (maximum). Branchement Magis en cascade avec Art. 1424.
- (NL) Schema voor aansluiting op hoofdingang van 30 Magis Kits (maximum) Aansluiting Magis in cascade met Art. 1424.

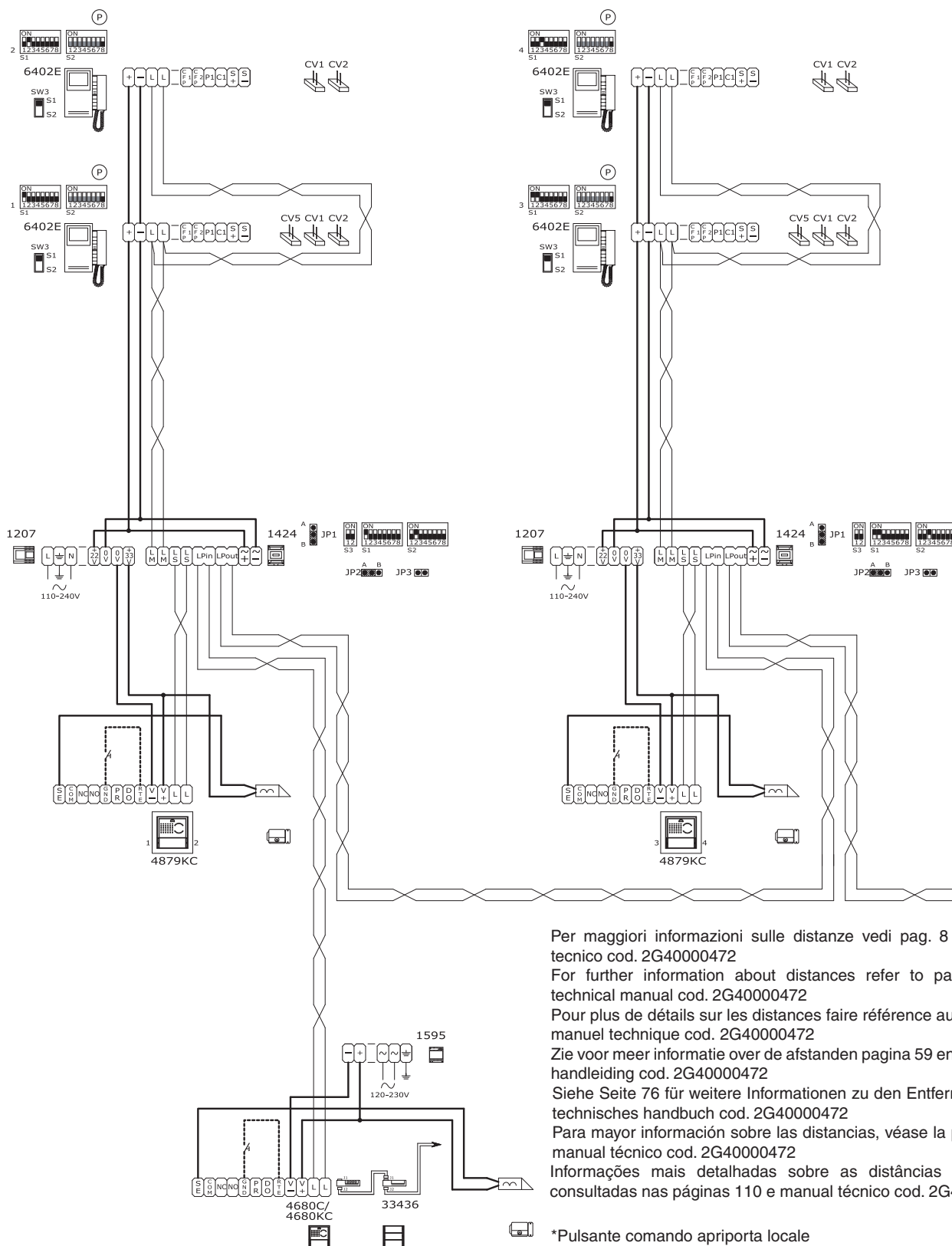

Per maggiori informazioni sulle distanze vedi pag. 8 e manuale tecnico cod. 2G40000472
 For further information about distances refer to page 25 and technical manual cod. 2G40000472
 Pour plus de détails sur les distances faire référence au page 42 et manuel technique cod. 2G40000472
 Zie voor meer informatie over de afstanden pagina 59 en technische handleiding cod. 2G40000472
 Siehe Seite 76 für weitere Informationen zu den Entfernungen und technisches handbuch cod. 2G40000472
 Para mayor información sobre las distancias, véase la página 93 y manual técnico cod. 2G40000472
 Informações mais detalhadas sobre as distâncias podem ser consultadas nas páginas 110 e manual técnico cod. 2G40000472

- *Pulsante comando apriporta locale
- *Local door-opener button
- *Bouton commande ouvre-porte local
- *Bedieningsknop lokale deuropener
- *Lokale Türöffnertaste
- *Pulsador abrepuertas local
- *Botão de comando abertura da porta local

DE Plan für den Anschluss von 30 Magis Kit (max.) an die Haupttür. Anschluss von Magis in Kaskadenschaltung mit Art. 1424.

ES Esquema para conectar a la puerta principal treinta Magis Kit (máximo). Conexión Magis en cascada con Art. 1424.

PT Esquema para a ligação com a porta principal de 30 Magis Kits (máximo). Ligação Magis em cascata com Art. 1424.

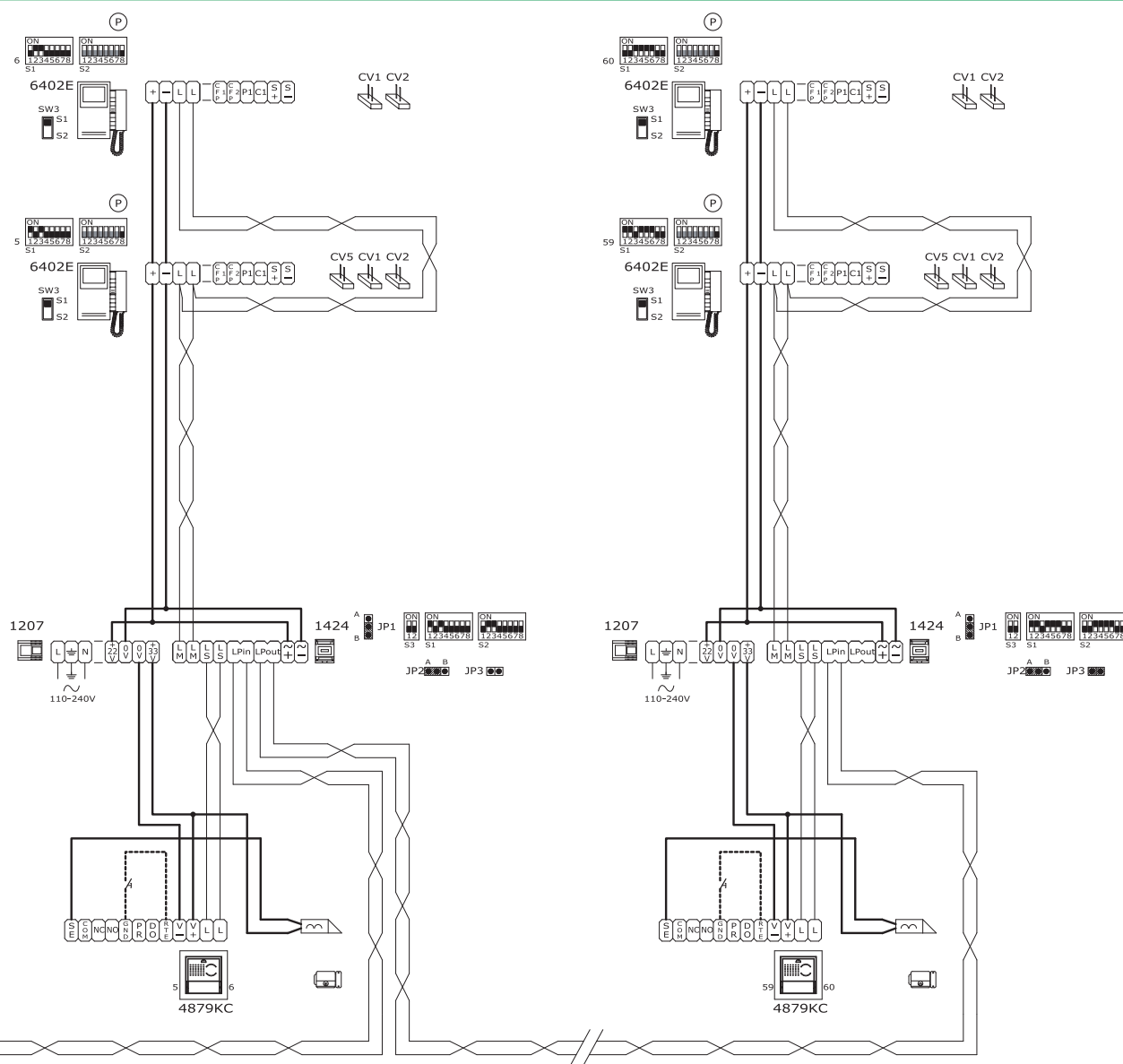

IT Limitazioni utilizzo Art. 4680KC

Il 4680KC gestisce le chiamate provenienti dai moduli pulsanti o digitali **SOLO** se comprese tra l'indirizzo 1 e l'indirizzo 10.

EN Operating restrictions for Art. 4680KC

Art. 4680KC manages calls originating from **ONLY** digital or button modules if they fall between address 1 and address 10.

FR Limitations utilisation Art. 4680KC

L'Art. 4680KC gère les appels provenant des modules à boutons ou numériques, **UNIQUEMENT** s'ils sont compris entre l'adresse 1 et l'adresse 10.

NL Gebruiksbeperkingen Art. 4680KC

De 4680KC beheert de oproepen die afkomstig zijn van de drukknopmodulen of digitale modulen **ALLEEN** als ze zich tussen het adres 1 en het adres 10 bevinden.

DE Verwendungseinschränkungen Art. 4680KC

Der Art. 4680KC verwaltet die von den Tasten- oder digitalen Rufmodulen eingehenden Anrufe **NUR**, wenn sie zwischen der Adresse 1 und der Adresse 10 liegen.

ES Limites de uso del Art. 4680KC

El Art. 4680KC gestiona las llamadas procedentes de los módulos de pulsadores o digitales **SÓLO** si están comprendidas entre la dirección 1 y la dirección 10.

PT Limitações de utilização do Art. 4680KC

O Art. 4680KC gere as chamadas provenientes dos módulos de botões ou digitais **APENAS** se estiver entre o endereço 1 e o endereço 10.

SB2/AAR

- Ⓜ IT Collegamento amplificatore video Art. 4833C
- Ⓜ EN Connection of video amplifier Art. 4833C
- Ⓜ FR Connexion amplificateur vidéo Art. 4833C
- Ⓜ NL Aansluiting van de videoversterker Art. 4833C

- Ⓜ DE Anschluss Videosignalverstärker Art. 4833C
- Ⓜ ES Conexión del amplificador vídeo Art. 4833C
- Ⓜ PT Ligação do amplificador vídeo Art. 4833C

LINEA MONTANTE
 RISER LINE
 LIGNE MONTANT
 KABEL STAMLEIDING
 STEIGLEITUNG
 LÍNEA COLUMNA MONTANTE
 LINHA COLUNA

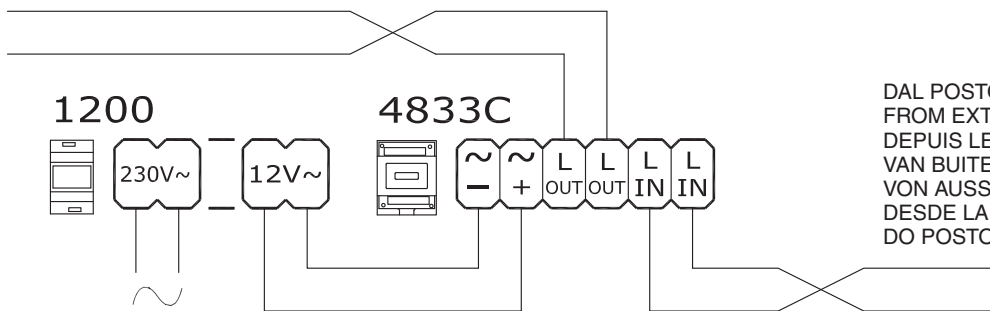

DAL POSTO ESTERNO
 FROM EXTERNAL UNIT
 DEPUIS LE POSTE EXTÉRIEUR
 VAN BUITENPOST
 VON AUSSENSTELLE
 DESDE LA UNIDAD EXTERNA
 DO POSTO EXTERNO

MSK/HCA

- Ⓜ IT Aggiunta di un monitor principale in parallelo. Collegamento in cascata
- Ⓜ EN Addition of a main monitor in parallel. Cascade connection
- Ⓜ FR Adjonction d'un moniteur principal en parallèle. Connexion en cascade
- Ⓜ NL Toevoeging van een hoofdmonitor in parallelschakeling. Aansluiting in cascade
- Ⓜ DE Zusätzliche Installation eines Hauptmonitors in Parallelschaltung, Kaskadenverbindung
- Ⓜ ES Adición de un monitor principal en paralelo. Conexión en cascada
- Ⓜ PT Adição de um monitor principal em paralelo. Ligaçao em cascata

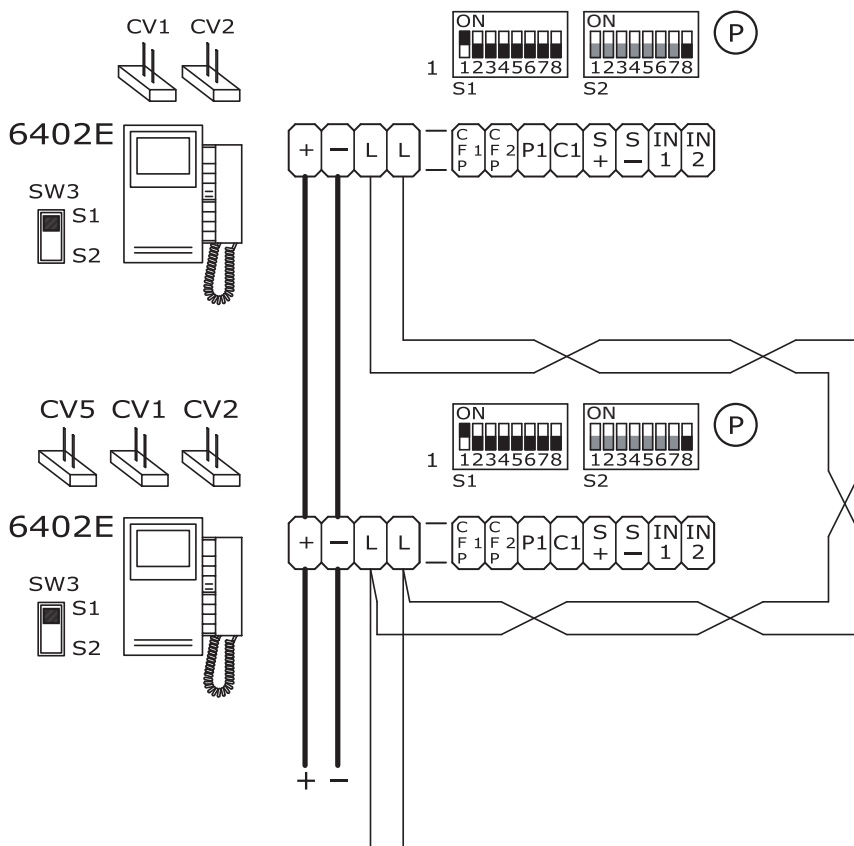

MSK/IC

- (IT) Aggiunta di un monitor principale in parallelo. Collegamento in derivazione
- (EN) Addition of a main monitor in parallel. Branch connection
- (FR) Adjonction d'un moniteur principal en parallèle. Connexion en dérivation
- (NL) Toevoeging van een hoofdmonitor. Afgetakte aansluiting
- (DE) Zusätzliche Installation eines Hauptmonitors in Parallelschaltung, Abzweigverbindung
- (ES) Adición de un monitor principal en paralelo. Conexión en derivación
- (PT) Adição de um monitor principal em paralelo. Ligaçao em derivação

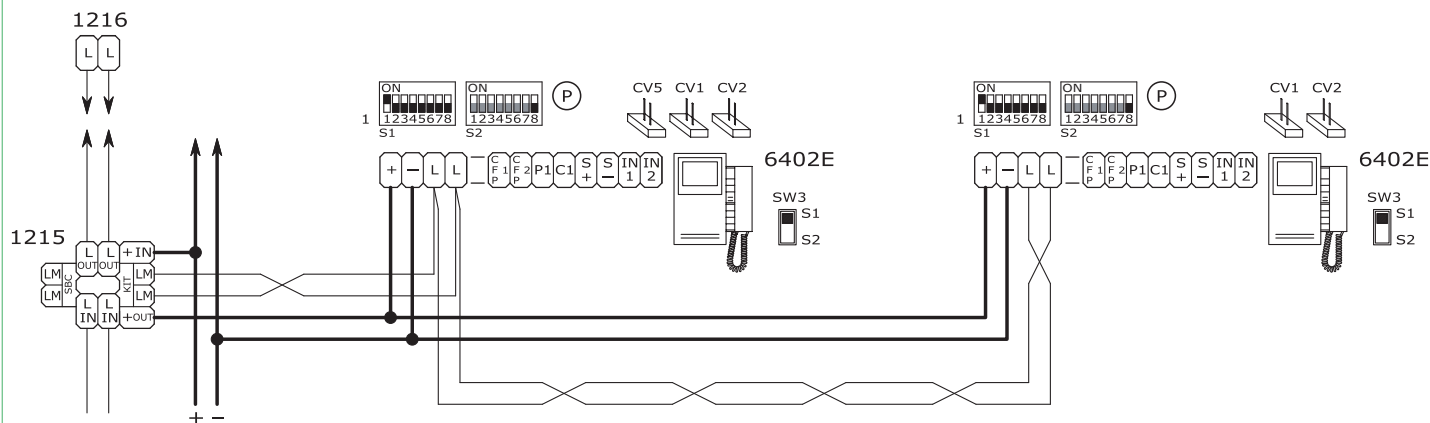

MSK/A20S

- (IT) Collegamento in cascata del terzo monitor principale con alimentazione locale
- (EN) Cascade connection of third main monitor with local power supply
- (FR) Connexion en cascade du troisième moniteur principal avec alimentation locale
- (NL) Aansluiting in cascade van een derde hoofdmonitor met individuele voeding
- (DE) Anschluss in Kaskadenschaltung des dritten Hauptmonitors mit lokaler Stromversorgung
- (ES) Conexión en cascada del tercer monitor principal con alimentación local
- (PT) Ligaçao em cascata do terceiro monitor principal com alimentação local

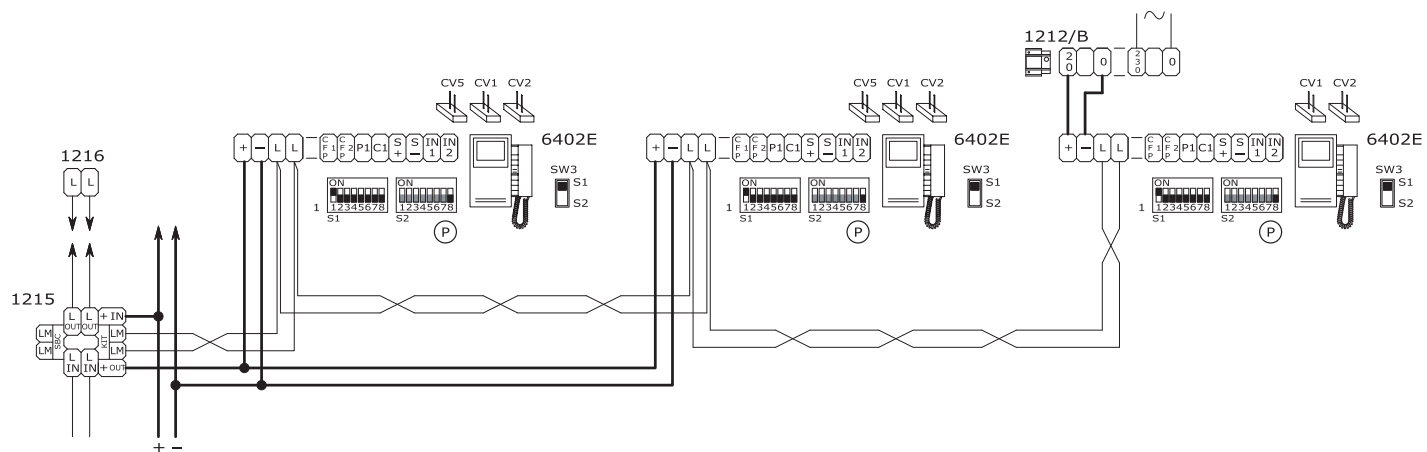

MSK/A23S

- (IT) Collegamento in derivazione di 2 monitor principali e di 2 monitor secondari con lo stesso codice utente
- (EN) Branch connection of 2 main monitors and 2 secondary monitors with the same user code
- (FR) Connexion en dérivation de 2 moniteurs principaux et de 2 moniteurs secondaires avec le même code usager
- (NL) Afgetakte aansluiting van 2 hoofdmonitors en 2 secundaire monitors met dezelfde gebruikerscode
- (DE) Anschluss über Abzweigung von 2 Hauptmonitoren und 2 Zusatzmonitor mit identischem Teilnehmercode
- (ES) Conexión en derivación de 2 monitores principales y 2 monitores secundarias con el mismo código de usuario
- (PT) Ligaçao em derivação de 2 monitores principais e de 2 monitores secundárias com o mesmo código de utilizador

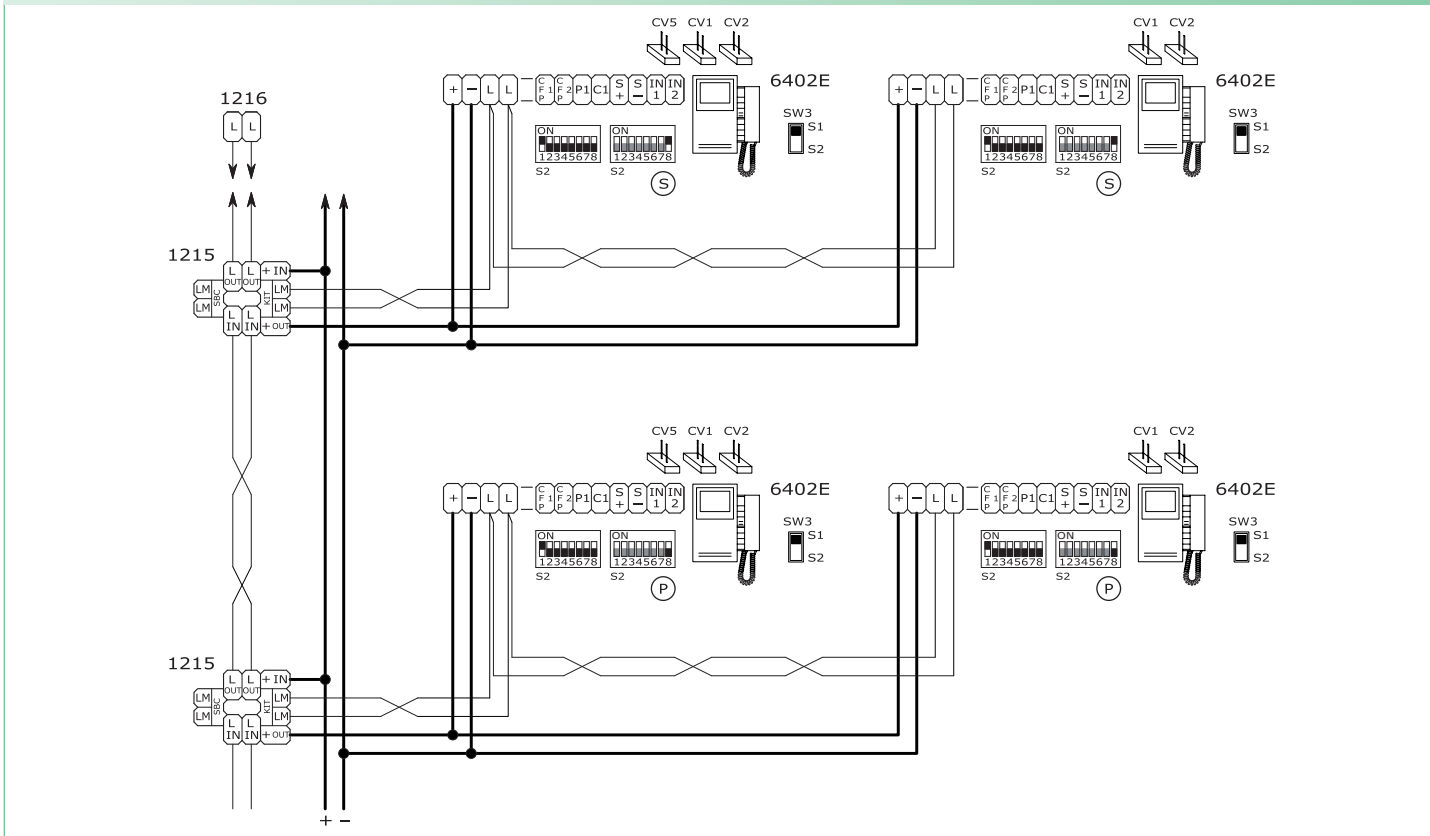

MSK/A21S

- (IT) Collegamento in cascata di 2 monitor principali e di 1 monitor secondario con lo stesso codice utente
- (EN) Cascade connection of 2 main monitors and 1 secondary monitor with the same user code
- (FR) Connexion en cascade de 2 moniteurs principaux et de 1 moniteur secondaire avec le même code usager
- (NL) Aansluiting in cascade van 2 hoofdmonitors en 1 secundaire monitor met dezelfde gebruikerscode
- (DE) Anschluss über Abzweigung von 2 Hauptmonitoren und 1 Zusatzmonitor mit identischem Teilnehmercode
- (ES) Conexión en cascada de 2 monitores principales y 1 monitor secundario con el mismo código de usuario
- (PT) Ligaçao em cascata de 2 monitores principais e de 1 monitor secundário com o mesmo código de utilizador

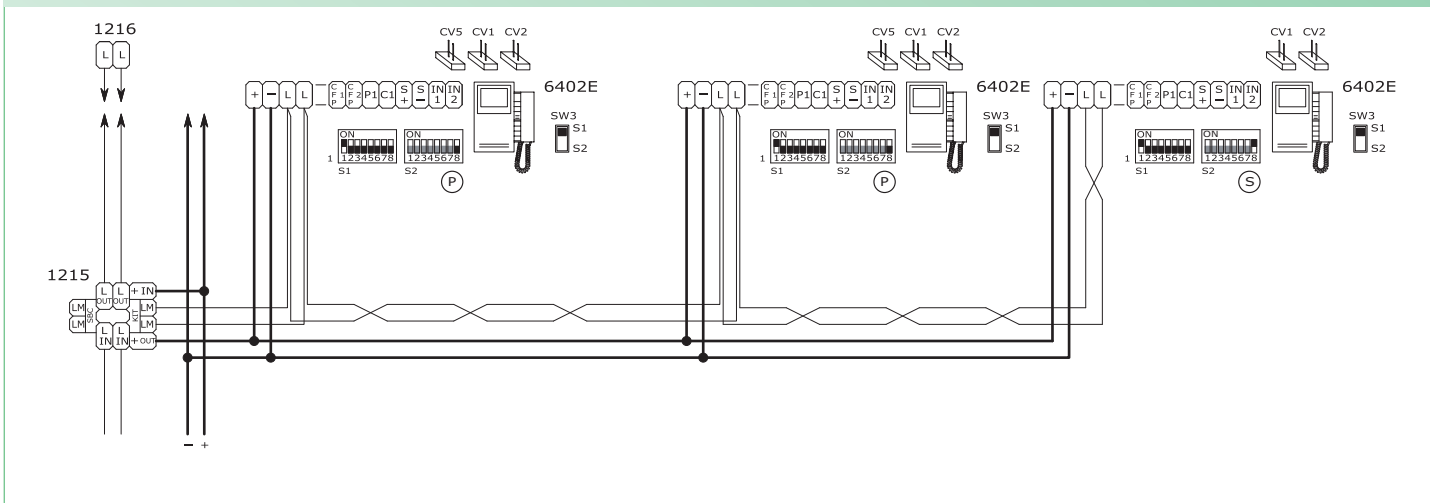

MSK/AAE

- (IT) Collegamento citofoni aggiuntivi in derivazione dal monitor
- (EN) Connection of additional door-entry phones with branch connection from monitor
- (FR) Connexion combinés parlophoniques supplémentaires en dérivation du moniteur
- (NL) Aansluiting van extra deurtelefoons afgetakt van de monitor
- (DE) Anschluss zusätzlicher Sprechstellen mit Abzweigung vom Monitor
- (ES) Conexión de telefonillos adicionales en derivación desde el monitor
- (PT) Ligação de telefones intercomunicadores suplementares em derivação do monitor

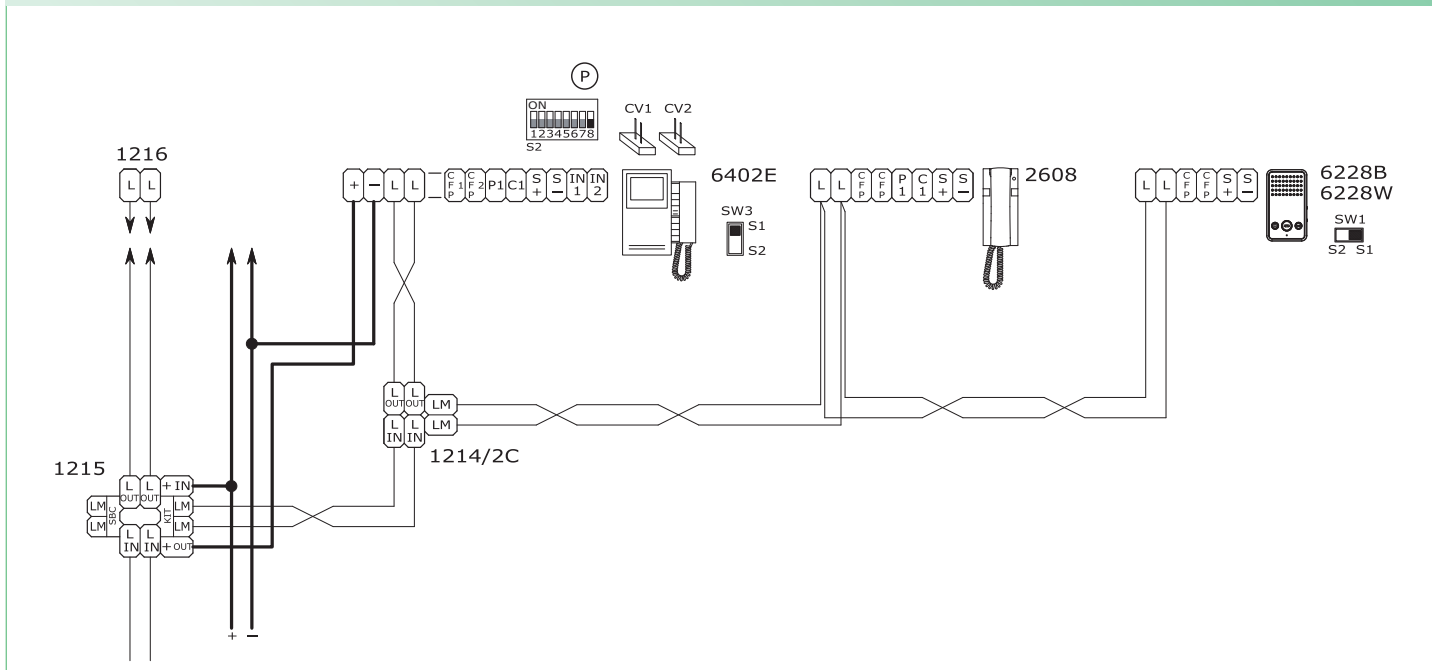

MSK/AAD

- (IT) Collegamento citofoni aggiuntivi in cascata dal monitor
- (EN) Connection of additional door-entry phones with cascade connection from monitor
- (FR) Connexion combinés parlophoniques supplémentaires en cascade du moniteur
- (NL) Aansluiting in cascade van extra deurtelefoons vanaf de monitor
- (DE) Anschluss zusätzlicher Sprechstellen in Kaskadenschaltung vom Monitor
- (ES) Conexión de telefonillos adicionales en cascada desde el monitor
- (PT) Ligação de telefones intercomunicadores suplementares em cascata do monitor

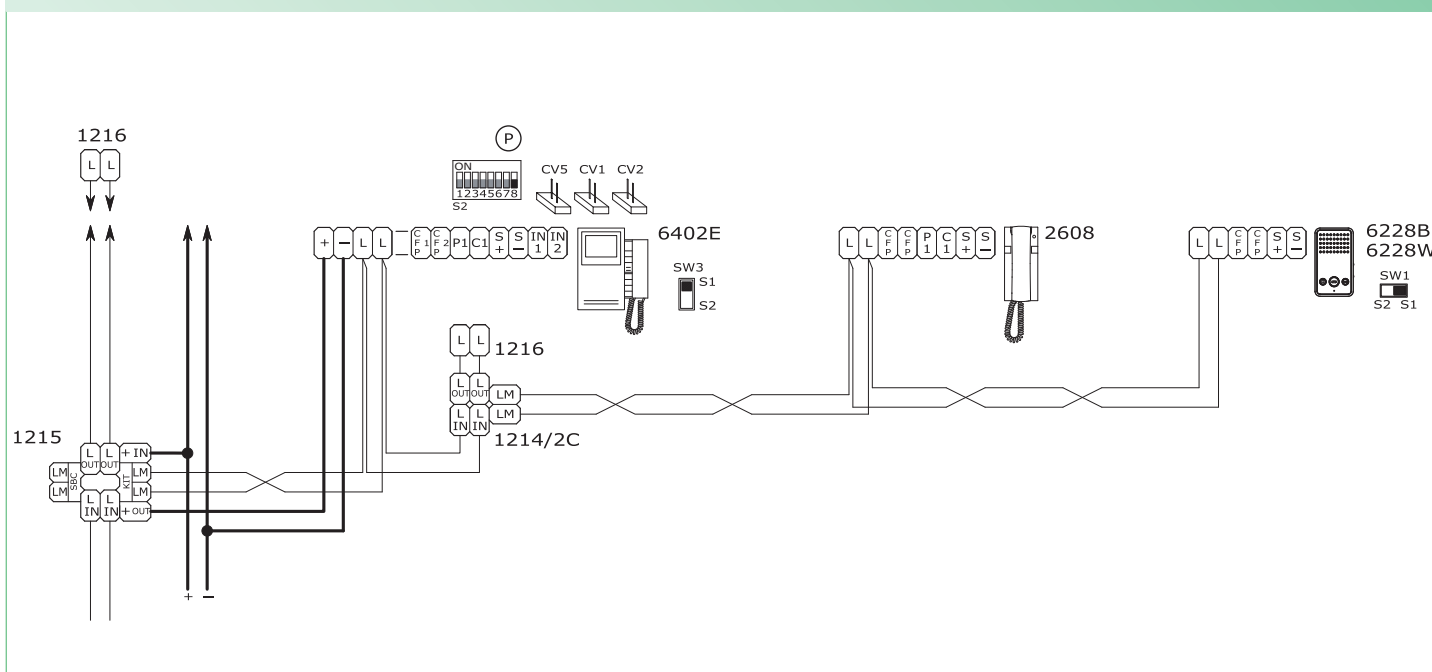

MSK/FC

- IT Aggiunta di un citofono in parallelo in derivazione dal montante
- EN Addition of a parallel door-entry phone, with branch connection from riser
- FR Adjonction d'un combiné parlophonique en parallèle en dérivation du montant
- NL Aansluiting in cascade van extra deure telefoons vanaf de monitor
- DE Anschluss zusätzlicher Sprechstellen in Kaskadenschaltung vom Monitor
- ES Conexión de telefonillos adicionales en cascada desde el monitor
- PT Ligação de telefones intercomunicadores suplementares em cascata do monitor

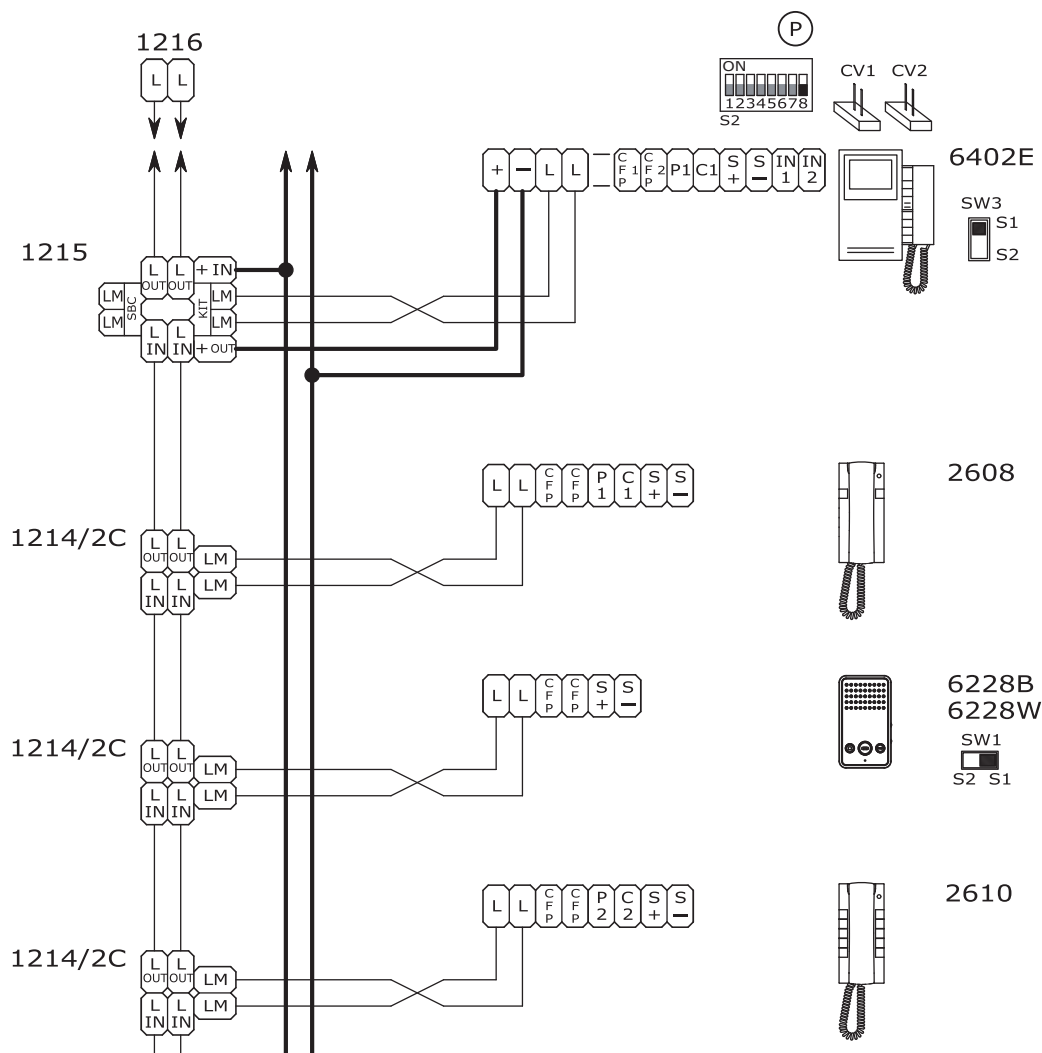

SB/X3

- IT Utilizzo per usi vari del pulsante P1 (Art. 2608)
- EN Use for various purposes of button P1 (Art. 2608)
- FR Utilisation pour usages divers du bouton P1 (Art. 2608)
- NL Gebruik voor verschillende doeleinden van drukknop P1 (Art. 2608)
- DE Verwendung von Taste P1 für sonstige Funktionen (Art. 2608)
- ES Pulsador P1 para varios usos (Art. 2608)
- PT Utilização do botão P1 para vários usos (Art. 2608)

Rimuovere i jumper CV1 e CV2
 Remove jumpers CV1 and CV2
 Enlever les cavaliers CV1 et CV2
 Verwijder de jumpers CV1 en CV2
 Jumper CV1 und CV2 entfernen
 Quitar los puentes CV1 y CV2
 Retirar os comutadores de derivação CV1 e CV2

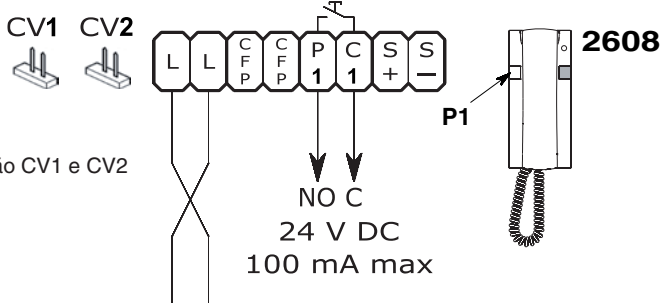

- IT** Connessione di dispositivi di ripetizione di chiamata (Art. 1229 o Art. 1122/A)
EN Connection of call repetition devices (Art. 1229 or Art. 1122/A)
FR Connexion de dispositifs de répétition d'appel (Art. 1229 ou Art. 1122/A)
NL Aansluiting van een extra bel (Art. 1229 of Art. 1122/A)
DE Anschluss von Rufwiederholeinrichtungen (Art. 1229 bzw. Art. 1122/A)
ES Conexión de dispositivos de repetición de llamada (Art. 1229 o Art. 1122/A)
PT Ligação de dispositivos de repetição da chamada (Art. 1229 ou Art. 1122/A)

- IT** La somma totale del numero di posti interni con stesso codice utente **non può superare il numero di 3**. Connettere un solo dispositivo di ripetizione di chiamata per ogni codice utente. In caso di connessione di carichi induttivi si consiglia l'inserimento di una capacità di 470nF in parallelo ai contatti C-NO dell'Art. 1122/A.
- EN** The total number of internal units with the same user code **cannot exceed 3**. Connect only one call repetition device for each user code. If inductive loads are connected, the insertion of a 470nF capacitor in parallel with the C-NO contacts of Art. 1122/A is recommended.
- FR** La somme totale du nombre de postes intérieurs avec le même code utilisateur **ne peut pas dépasser 3**. Brancher un seul dispositif de répétition d'appel pour chaque code utilisateur. En cas de connexion de charges inductives, il est conseillé d'installer une capacité de 470nF en parallèle aux contacts C-NO de l'Art. 1122/A.
- NL** Het totale aantal interne aansluitingen met dezelfde gebruikerscode **mag niet meer zijn dan 3**. Sluit één extra bel aan per gebruikerscode. Bij het aansluiten van inductieve belastingen wordt aangeraden een condensator van 470nF parallel met de C-NO-contacten van Art. 1122/A te plaatsen.
- DE** Die Gesamtanzahl der Innensprechstellen mit dem gleichen Benutzercode **darf nicht höher als 3 sein**. Jeweils nur eine Rufwiederholeinrichtung pro Benutzercode anschließen. Im Fall des Anschlusses von induktiven Lasten empfiehlt sich die Verbindung mit einer Kapazität von 470nF in Parallelschaltung zu den C-NO Kontakten des Art. 1122/A.
- ES** Las unidades internas totales con el mismo código de usuario **no pueden ser más de 3**. Conectar un único dispositivo de repetición de llamada para cada código de usuario. En caso de conexión de cargas inductivas es aconsejable la conexión de una capacidad de 470nF en paralelo a los contactos C-NO del Art. 1122/A.
- PT** A soma total do número de postos internos com o mesmo código de utilizador **não pode ser superior a 3**. Ligar apenas um dispositivo de repetição de chamada para cada código de utilizador. Em caso de conexão de cargas indutivas aconselha-se a introdução de uma resistência de 470 nF em paralelo aos contactos C-NO do Art.1122/A.

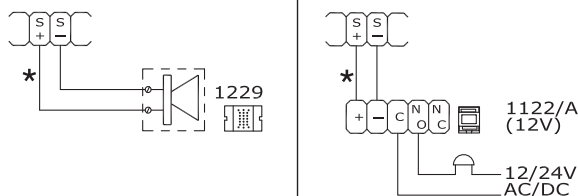

- IT** Variante collegamento chiamata fuori porta
EN Floor door call connection variant
FR Variante connexion appel palier
NL Variant met aansluiting van een etagebel
- DE** Anschlussvariante Rufsignale der Außensprechstellen
ES Variante con conexión para llamada timbre de planta
PT Variante para ligação da campainha externa

- IT** In caso di più citofoni o staffe monitor con lo stesso codice utente collegare il pulsante CFP su uno solo; tutti i dispositivi suoneranno contemporaneamente.
- EN** If there are a number of door-entry phones or monitor brackets with the same user code, connect the CFP button to one only; all the devices will ring simultaneously.
- FR** En cas de plusieurs combinés parlophoniques ou étriers moniteur avec le même code usager, relier le bouton CFP sur un seul ; tous les dispositifs sonneront en même temps.
- NL** Sluit bij meerdere deurtelefoons of grondplaten met dezelfde gebruikerscode de drukknop CFP op slechts één ervan aan; alle toestellen gaan dan tegelijk over.
- DE** Im Fall mehrerer Sprechstellen oder Monitor-Grundplatten mit gleichem Teilnehmercode die CFP-Taste nur an ein Gerät anschließen; daraufhin ertönt an allen Geräten gleichzeitig der Rufton.
- ES** En caso de varios telefonillos o placas soporte de monitor con el mismo código de usuario, conectar el pulsador CFP a uno sólo; todos los dispositivos se activarán al mismo tiempo.
- PT** No caso de vários telefones intercomunicadores ou suportes de monitor com o mesmo código de utilizador, ligar o botão CFP num só; todos os dispositivos soarão em simultâneo.

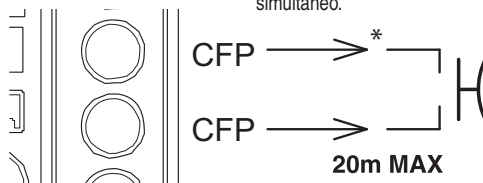

- IT** * **20 m MAX** - Utilizzare cavo schermato per il collegamento e non far passare i cavi in prossimità di carichi induttivi pesanti o cavi di alimentazione (230V / 400V).
- EN** * **20 m MAX** - Use screened cable for the connection and do not run cables near heavy inductive loads or power supply cables (230V / 400V).
- FR** * **20 m MAX** - Pour la connexion, utiliser un câble blindé et ne pas faire passer les câbles à proximité de charges inductives lourdes ou de câbles d'alimentation (230 V / 400 V).
- NL** * **20 m MAX** - Gebruik een afgeschermd kabel voor deze verbinding en leid de kabels niet in de nabijheid van hoge inductieve belastingen of voedingskabels (230 V / 400 V).
- DE** * **20 m MAX** - Für den Anschluss abgeschirmte Kabel verwenden und die Kabel nicht in der Nähe von großen induktiven Lasten oder Stromversorgungskabeln (230V / 400V) verlegen.
- ES** * **20 m MAX** - Utilizar cable blindado para la conexión y no tender los cables cerca de cargas inductivas pesadas o cables de alimentación (230V / 400V).
- PT** * **20 m MAX** - Utilizar cabo blindado para a ligação e não fazer passar os cabos nas proximidades de cargas indutivas pesadas ou de cabos de alimentação (230V / 400V).

- Ⓘ Utilizzo ingresso IN1 come contatto per segnalazione LED/ALLARME/APRIPORTA/ATTUATORE. Attivazione in chiusura verso CFP2
- Ⓔ Using IN1 input for LED/ALARM/LOCK-RELEASE/ACTUATOR indication. Activation on closure towards CFP2
- Ⓕ Utilisation de l'entrée IN1 comme contact pour signal LED/ALARME/OUVRE-PORTE/ACTIONNEUR. Activation en fermeture vers CFP2
- Ⓖ Gebruik ingang IN1 als contact voor signalering LED/ALARM/DEUROPENER/RELAIS. Activering bij sluiting naar CFP2
- Ⓓ Verwendung des Eingangs IN1 als Meldekontakt LED/ALARM/TÜRÖFFNER/RELAIS. Aktivierung bei Schließen des Kontakts zwischen IN1 und CFP2
- Ⓔ Uso de la entrada IN1 como contacto para señalización de LED/ALARMA/ABREPUERTAS/ACTUADOR. Se activa al cerrar el contacto con CFP2
- Ⓕ Utilização da entrada IN1 como contacto para a indicação LUZ INDICADORA/ALARME/ABERTURA DA PORTA/ACTUADOR. Activação perante fecho entre IN1 e CFP2

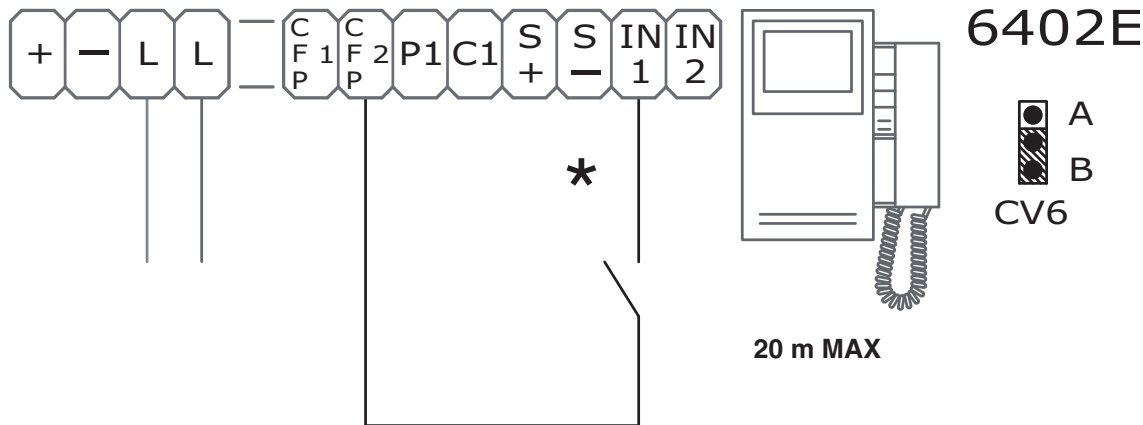

- Ⓘ Utilizzo ingresso IN1 come contatto per segnalazione LED/ALLARME/APRIPORTA/ATTUATORE. Attivazione in presenza di tensione rispetto a IN2
- Ⓔ Using IN1 input for LED/ALARM/LOCK-RELEASE/ACTUATOR indication. Activation in the presence of voltage in relation to IN2
- Ⓕ Utilisation de l'entrée IN1 comme contact pour signal LED/ALARME/OUVRE-PORTE/ACTIONNEUR. Activation en présence de tension par rapport à IN2
- Ⓖ Gebruik ingang IN1 als contact voor signalering LED/ALARM/DEUROPENER/RELAIS. Activering bij aanwezigheid van spanning ten opzichte van IN
- Ⓓ Verwendung des Eingangs IN1 als Meldekontakt LED/ALARM/TÜRÖFFNER/RELAIS. Aktivierung bei Anliegen von Spannung im gegenüber IN2
- Ⓔ Uso de la entrada IN1 como contacto para señalización de LED/ALARMA/ABREPUERTAS/ACTUADOR. Se activa cuando hay tensión con relación a IN2
- Ⓕ Utilização da entrada IN1 como contacto para a indicação LUZ INDICADORA/ALARME/ABERTURA DA PORTA/ACTUADOR. Activação na presença de tensão comparativamente a IN2

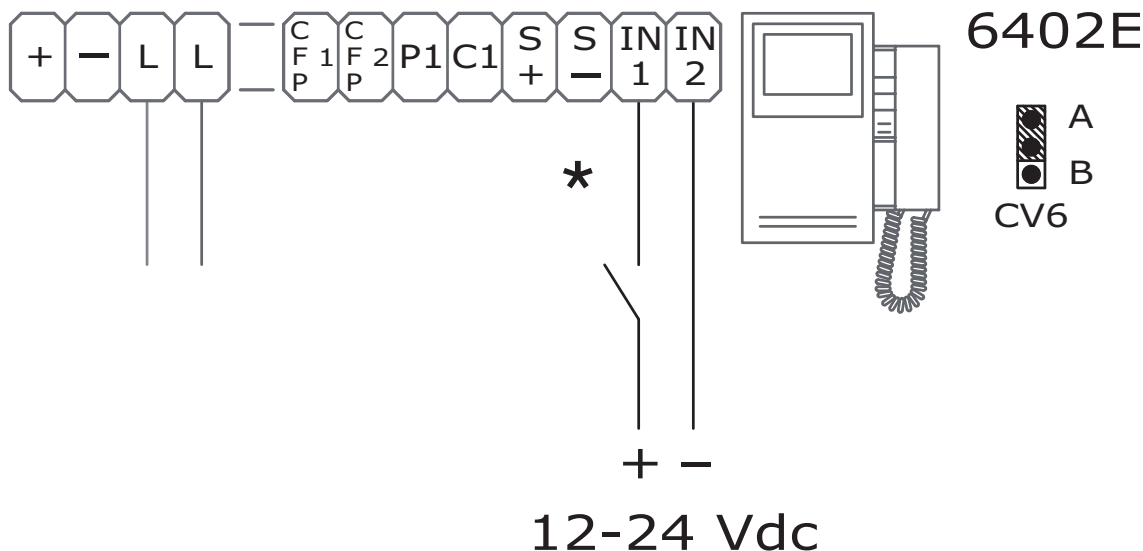

- Ⓘ * Ingresso da programmare, vedi pag. 16
In funzione segnalazione LED il led di segnalazione privacy attiva/ impianto occupato lampeggia.
- Ⓔ * Input to be programmed, see page 33
Depending on the LED indication, the privacy active/system busy indication LED flashes.
- Ⓕ * Entrée à programmer, voir page 50
En fonction du signal LED, la led d'indication de privacy active/ système occupé clignote.
- Ⓖ * Ingang te programmeren, zie pag. 67
In de functie signalering LED zal de led voor signalering privacy actief/ systeem bezet knipperen.
- Ⓓ * Zu programmierender Eingang, siehe Seite 84
Wenn die LED-Meldefunktion aktiv ist, blinkt die LED-Anzeige für Privacy-Funktion aktiv/Anlage besetzt.
- Ⓔ * Entrada por programar, véase pág. 101 Programada para la señalización de led, el led correspondiente parpadea para indicar que la función privacidad está activada o la instalación ocupada.
- Ⓕ * Entrada a programar, consultar a pág. 118
Com a indicação luz indicadora activada, a luz indicadora de indicação de privacidade activada/instalação ocupada pisca.

SB2/AAM2

- (IT) Utilizzo per usi vari del pulsante P1
- (EN) Use for various purposes of button P1
- (FR) Utilisation pour usages divers du bouton P1
- (NL) Gebruik voor verschillende doeleinden van drukknop P1
- (DE) Verwendung von Taste P1 für sonstige Funktionen
- (ES) Pulsador P1 para varios usos
- (PT) Utilização do botão P1 para vários usos

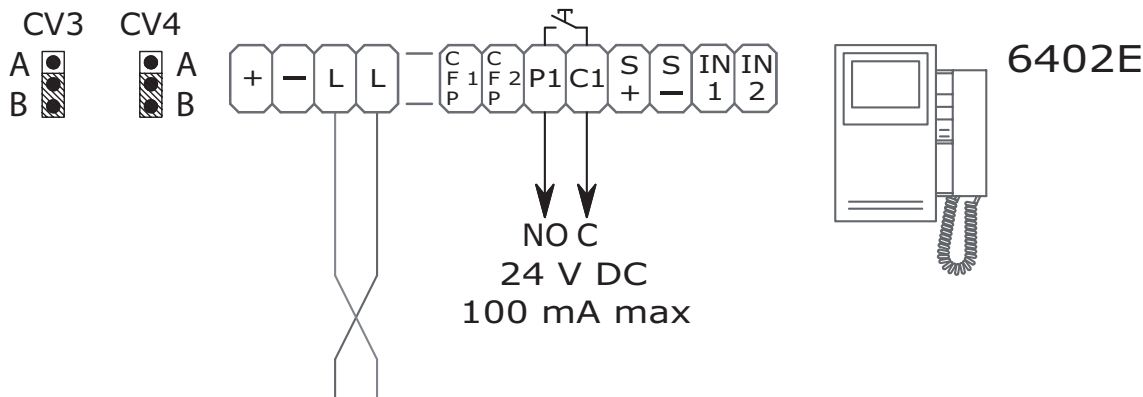

Per avere un contatto C.NO. (24V-100mA max) spostare in posizione B i jumper CV3 e CV4.
 To have a C.NO. contact (24 V-100 mA max.), move jumpers CV3 and CV4. to position B.
 Pour avoir un contact C.NO. (24V-100mA maxi), déplacer les cavaliers CV3 et CV4 sur la position B.
 Voor een C.NO.-contact (max. 24V-100mA) zet u de jumpers CV3 en CV4 op stand B.
 Zur Herstellung eines Schließerkontakts (max. 24V – 100mA) die Stecker CV3 und CV4 in Stellung B versetzen.
 Para obtener un contacto normalmente abierto (24 V - 100 mA máx.) poner los puentes CV3 y CV4 en posición B.
 Para obter um contacto C.NO. (24 V-100 mA máx.) colocar os comutadores de derivação CV3 e CV4 na posição B.

PXK/RTNP

- (IT) Utilizzo relé posto esterno su apriporta o comando attuatore (vedi programmazioni speciali pag.18: gestione comando attuatore)
- (EN) Using the external unit relay on lock-release or actuator control (see special programming, page 35: actuator control management)
- (FR) Utilisation relais poste extérieur sur ouvre-porte ou commande actionneur (voir programmations spéciales, page 52 : gestion commande actionneur)
- (NL) Gebruik relais entreepaneel op deuropener of relaissturing (zie Speciale programmeringsmogelijkheden, pag. 69: Beheer relaissturing)
- (DE) Verwendung des Relais der Außensprechstelle als Türöffner oder zur Relaisansteuerung (siehe Besondere Programmierungen, Seite 86: Relaisansteuerung)
- (ES) Uso del relé de la unidad externa en el abrepuertas o mando actuador (véase Programaciones especiales en la pág 103: Gestión del mando actuador)
- (PT) Utilização do relé do posto exterior para abertura de porta ou comando actuador (vide Programações especiais da Pág 120: Gestão do comando actuador)

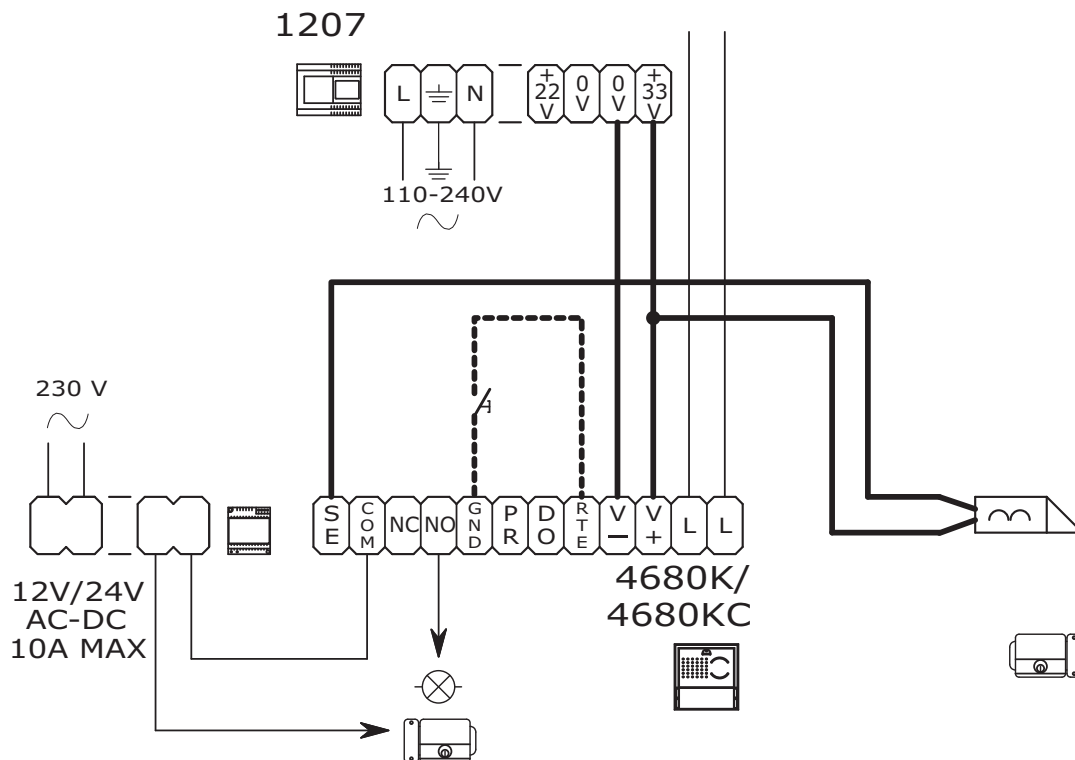

PXK/SNP

- (IT) Variante con serratura di sicurezza e alimentazione aggiuntiva
- (EN) Variant with security door lock and additional power supply
- (FR) Variante avec gâche de sécurité et alimentation supplémentaire
- (NL) Variant met veiligheidsslot en extra voeding
- (DE) Variante mit Sicherheits-Türöffner und zusätzlicher Stromversorgung
- (ES) Variante con cerradura de seguridad y alimentación adicional
- (PT) Variante com fechadura de segurança e alimentação suplementar

1207

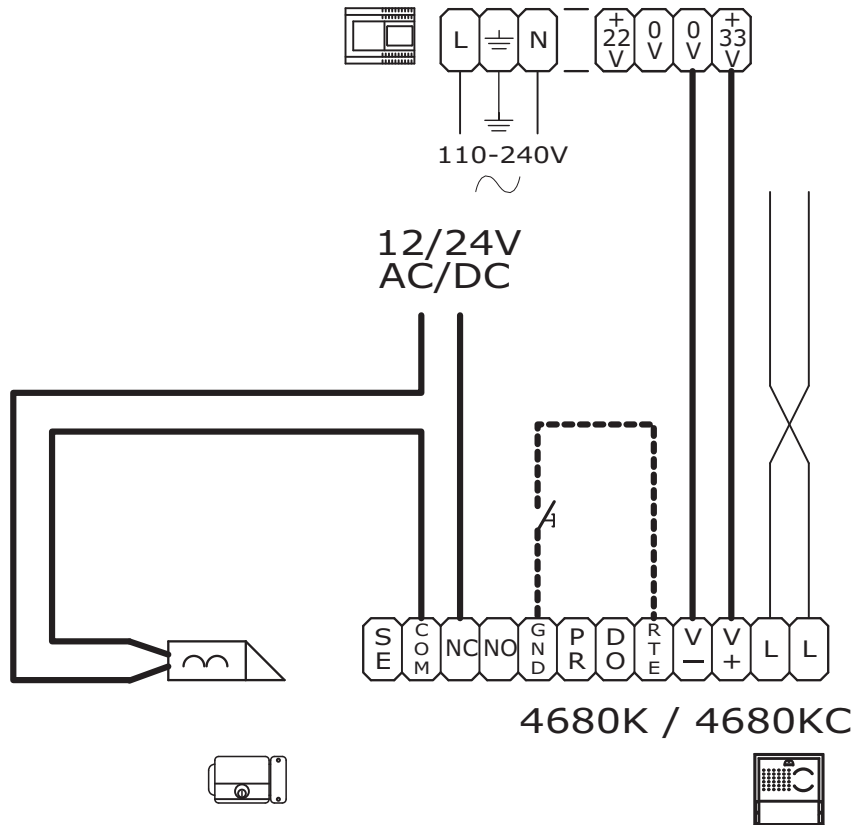

- (IT) Utilizzo della rete RC per filtro serratura sui contatti del relè
- (EN) Using the RC network for door lock filter on relay contacts
- (FR) Utilisation du réseau RC pour filtre gâche sur les contacts du relais
- (NL) Gebruik van het RC-net voor storingsfilter op de contacten van het relais
- (DE) Verwendung des RC-Glieds als Türöffner-Filter an den Relaiskontakten
- (ES) Uso de la red RC para el filtro de la cerradura en los contactos del relé
- (PT) Utilização da rede RC para filtrar a fechadura nos contactos do relé

Sui contatti C. NO.
On contacts C. NO.
Sur les contacts C. NO.
Op de C. NO-contacten.
An den Schließerkontakten
En los contactos normalmente abiertos
Nos contactos C. NO.

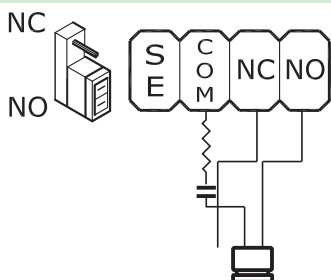

Sui contatti C. NC.
On contacts C. NC.
Sur les contacts C. NC.
Op de C. NC-contacten.
An den Schließerkontakt
En los contactos normalmente cerrado
Nos contactos C. NC.

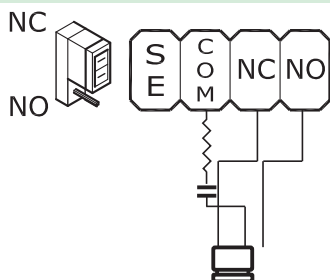

Esclusa: contatto pulito
Disabled: clean contact
Exclue : contact libre
Met uitzondering van: potentiaalvrij contact
Ausgenommen: potentialfreier Kontakt
Excluido: contacto libre de potencial
Exclusão: contacto limpo

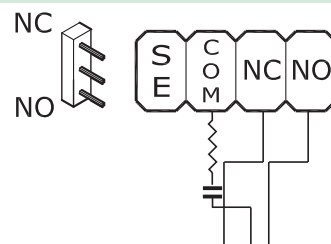

- Ⓜ **IT** Variante utilizzo segnalazione porta aperta.
Da utilizzare solo in impianti con 1 solo posto esterno senza scambi Art. 1224A, Art. 1424.
- Ⓜ **EN** Door open indication use variant.
Only for use in systems with a single external unit without switching devices Art. 1224A, Art. 1424.
- Ⓜ **FR** Variante utilisation signalisation porte ouverte.
À utiliser uniquement dans les installations avec 1 seul poste extérieur sans commutateur Art. 1224A, Art. 1424.
- Ⓜ **NL** Gebruiksvariant van de signalering 'deur open'.
Alleen te gebruiken bij installaties met slechts 1 entreepaneel zonder deurselectoren Art. 1224A, Art. 1424.
- Ⓜ **DE** Einsatzvariante der Meldung TÜR OFFEN.
Verwendung nur in Anlagen mit 1 Außensprechstelle ohne Signalweichen Art. 1224A u. Art. 1424.
- Ⓜ **ES** Variante para el uso de la señalización de puerta abierta.
Se ha de utilizar sólo en instalaciones con 1 unidad externa sin conmutadores Art. 1224A o Art. 1424.
- Ⓜ **PT** Variante para a utilização da indicação porta aberta.
Utilizar apenas em instalações com 1 único posto externo sem comutador Art. 1224A, Art. 1424.

- * Ⓜ **IT** Contatto N.C. per segnalazione PORTA APERTA (il led dei posti interni lampeggia).
- Ⓜ **EN** N.C. contact for DOOR OPEN signalling (the LED of the internal units flashes).
- Ⓜ **FR** Contact N.F. pour signalisation PORTE OUVERTE (la led des postes intérieurs clignote).
- Ⓜ **NL** Contact N.C. voor signalering DEUR OPEN (de led van de interne aansluitingen knippert)
- Ⓜ **DE** Schließerkontakt zur Meldung OFFENE TÜR (LED der Innensprechstellen blinkt)
- Ⓜ **ES** Contacto N.C. para la señalización de puerta abierta (el led de las unidades internas parpadea)
- Ⓜ **PT** Contacto para indicação PORTA ABERTA (a luz piloto dos locais internos pisca)

1207

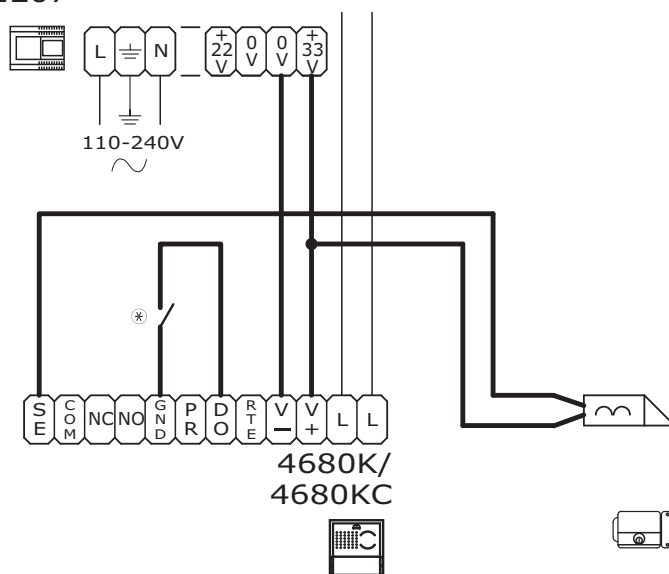

A series of horizontal green lines spaced evenly down the page, providing a template for handwriting practice.

