

Manuale tecnico Magis Kit monofamiliare Art. 8471MC
Technical manual for single-family Magis Kit Art. 8471MC
Manuel technique Magis Kit un usager Art. 8471MC
Technische handleiding Magis Kit eengezinswoning Art. 8471MC
**Technisches Handbuch Magis Kit Türsprechanlage
für Einfamilienhaus Art. 8471MC**
Manual técnico Magis Kit unifamiliar Art. 8471MC
Manual técnico Magis Kit monofamiliar Art. 8471MC

www.comelitgroup.com



Avvertenze

- Effettuare l'installazione seguendo scrupolosamente le istruzioni fornite dal costruttore ed in conformità alle norme vigenti.
- Tutti gli apparecchi devono essere destinati esclusivamente all'uso per cui sono stati concepiti. **Comelit Group S.p.A.** declina ogni responsabilità per un utilizzo improprio degli apparecchi, per modifiche effettuate da altri a qualunque titolo e scopo, per l'uso di accessori e materiali non originali.
- Tutti i prodotti sono conformi alle prescrizioni delle direttive 2006/95/CE (che sostituisce la direttiva 73/23/CEE e successivi emendamenti) e ciò è attestato dalla presenza della marcatura **CE** sugli stessi.
- Evitare di porre i fili di montante in prossimità di cavi di alimentazione (230/400V).
- Non inserire oggetti né versare liquidi all'interno del dispositivo.
- Gli interventi di installazione, montaggio e assistenza agli apparecchi elettrici devono essere eseguiti esclusivamente da elettricisti specializzati.
- Togliere l'alimentazione prima di effettuare qualsiasi manutenzione.
- Connettere il telaio porta moduli a terra (vedi Fig.)
- Non tenere premuto il gancio fonica con la cornetta sollevata.
- La telecamera non deve essere installata di fronte a grandi sorgenti luminose, oppure in luoghi dove il soggetto ripreso rimanga molto in controluce. Per risolvere il problema precedentemente descritto, si consiglia di modificare l'altezza di installazione della telecamera, solitamente 160 - 165 cm, ad un'altezza di 180 cm e di orientare l'obiettivo verso il basso in modo da migliorare la qualità delle riprese.
- Le telecamere con sensore CCD a colori, presentano in condizioni di scarsa luminosità, una sensibilità inferiore rispetto alle telecamere in bianco e nero. Si consiglia pertanto, in ambienti poco illuminati di prevedere una fonte di illuminazione aggiuntiva.

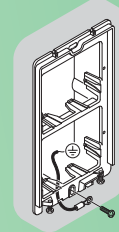

Generalità	3
Posto esterno	3
Art. 4882	3
Art. 1205/B	3
Installazione posto esterno	4
Posti interni	5
Montaggio posto interno Magis	5
Sgancio del monitor	5
Art. 6402E	6
Descrizione monitor	6
Art. 2608	7
Installazione citofono Art. 2608	7
Indicazioni generali di installazione e funzionamento	8
Tabella distanze di funzionamento	8
Funzionamento	8
Descrizione impostazioni e funzionamento pulsanti	9
Impostazione monitor Art. 6402E e citofono Art. 2608	9
TAB. A Indirizzi di montante	9
Descrizione funzione Pulsanti	9
Monitor supplementari principali o secondari	10
Configurazioni pulsanti di default	10
Avvertenze generali programmazione pulsanti	10
Programmazioni pulsanti per attuatore generico o indirizzato	11
Programmazioni per chiamata intercomunicante	11
Programmazione/cancellazione indirizzo intercomunicante (solo per intercomunicante selettivo)	11
TAB. B Indirizzi intercomunicante selettivo	11
Programmazioni pulsanti per chiamata intercomunicante	12
Programmazioni pulsanti per altre funzioni	12
TAB. C Indirizzi di montante	13
Reset programmazione	13
Programmazione range/suonerie	14
Programmazione ingresso IN1 per segnalazione led/allarme/apriporta/attuatore	15
Programmazione diretta chiamata intercomunicante	16
Variazione suonerie monitor	16
Programmazioni speciali Art. 4882	17
Schemi di collegamento	
MSK/012C Schema base per kit monofamiliari Art. 8471MC. Messa in funzione/verifica tensioni di impianto a riposo	114
MSK/017AC Schema per kit monofamiliari Art. 8471MC ampliati con un secondo Art. 4882.....	115
MSK/012/AC Schema per kit monofamiliare con alimentatore aggiuntivo Art. 1395.....	116
MSK/015C Utilizzo modulo telecamera scorporata Art. 1259C.....	117
SB2/AAR Collegamento amplificatore video Art. 4833C.....	118
MSK/HCA Aggiunta di un monitor principale in parallelo. Collegamento in cascata	118
MSK/IC Aggiunta di un monitor principale in parallelo. Collegamento in derivazione	119
MSK/A20S Collegamento in cascata del terzo monitor principale con alimentazione locale.....	119
MSK/A23S Collegamento in derivazione di 2 monitor principali e di 2 monitor secondari con lo stesso codice utente	120
MSK/A21S Collegamento in cascata di 2 monitor principali e di 1 monitor secondario con lo stesso codice utente	120
MSK/AAE Collegamento citofoni aggiuntivi in derivazione dal monitor.....	121
MSK/AAD Collegamento citofoni aggiuntivi in cascata dal monitor	121
MSK/FC Aggiunta di un citofono in parallelo in derivazione dal montante	122
SB/X3 Utilizzo per usi vari del pulsante P1 (Art. 2608)	122
SB2V/AAK Connessione di dispositivi di ripetizione di chiamata (Art. 1229 o Art. 1122/A)	123
Variante collegamento chiamata fuori porta.....	123

Utilizzo ingresso IN1 come contatto per segnalazione LED/ALLARME/APRIPORTA/ATTUATORE. Attivazione in chiusura verso CFP2.....	124
Utilizzo ingresso IN1 come contatto per segnalazione LED/ALLARME/APRIPORTA/ATTUATORE. Attivazione in presenza di tensione rispetto a IN2 ...	124
SB2/AAM2 Utilizzo per usi vari del pulsante P1	125
SMK/EC Collegamento relé attuatore Art. 1256.....	125
GK/AAGC Variante collegamento apriporta locale temporizzato	126
SMK/SNP Variante con serratura di sicurezza e alimentazione aggiuntiva	126
Utilizzo della rete RC per filtro serratura sui contatti del relé	127

Generalità

I Kit video citofonici monofamiliare Art. 8471MC sono utilizzabili in edifici civili o terziari dove è richiesto un'efficace controllo di accesso a fronte di semplici operazioni di installazione.

Infatti bastano 2 conduttori tra il posto esterno e il/i monitor interni per attivare il sistema (chiamata, fonica, video, autoaccensione), più 2 fili per alimentare il posto esterno e l'elettroserratura e 2 fili per alimentare il posto interno videocitofonico.

È disponibile inoltre una vasta gamma di accessori per risolvere facilmente ogni esigenza di impianto; infatti oltre a interessanti accessori di tipo standard è possibile ampliare l'impianto aggiungendo videocitofoni e/o citofoni e/o posti esterni.

In questo modo si può raggiungere un massimo di 2 posti esterni con 4 posti interni tra citofoni e videocitofoni per la configurazione monofamiliare.

Tramite opportune impostazioni è possibile effettuare comunicazioni intercomunicanti monofamiliari (cioè tra utenti con il medesimo codice utente) utilizzando sia videocitofoni che citofoni.

Più Kit possono essere connessi a una porta principale Simplebus e/o a un centralino Art. 1998A.

Posto esterno

Art. 4882

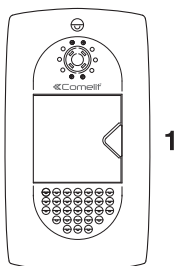

Art. 1205/B

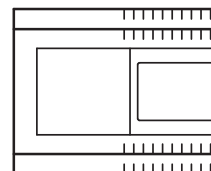

Caratteristiche tecniche

Connessione al monitor con 2 fili per audio, video, apriporta e chiamata più 2 fili per alimentazione da Art. 1205/B.

Telecamera orientabile ad alta sensibilità con sensore CCD 1/3".

Illuminazione LED bianchi (6 LED).

Cartellini portanome con illuminazione a LED.

Regolazione volume microfono e altoparlante.

Dimensione scatola da incasso: 176,5x95,5x35 mm.

Il pulsante dell'Art. 4882 è impostato di fabbrica per effettuare la chiamata all'indirizzo 1.

Dimensione posto esterno: 176x95x15 mm.

Descrizione morsettiera

LL connessione monitor (video, chiamata, fonica, apriporta).

- RTE ingresso apriporta locale temporizzato.

~ ~ alimentazione posto esterno.

SE. NC. - SE NO. - SE C. connessione elettroserratura.

Caratteristiche tecniche

Il trasformatore prevede 2 uscite: una per alimentare il posto esterno e l'elettroserratura, l'altra per alimentare il monitor.

Dimensioni: 105x85x85 mm (6 moduli DIN).

Fusibile di protezione 500mA ritardato.

Descrizione morsettiera

AC230V ingresso tensione di rete.

~ ~ uscita AC per posto esterno e elettroserratura.

+ - uscita 20V DC di alimentazione del monitor.

Installazione posto esterno

IT

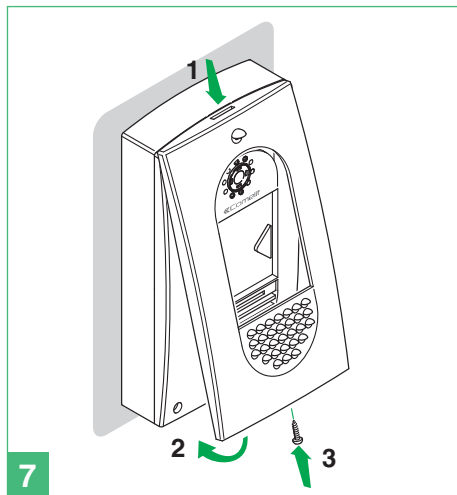
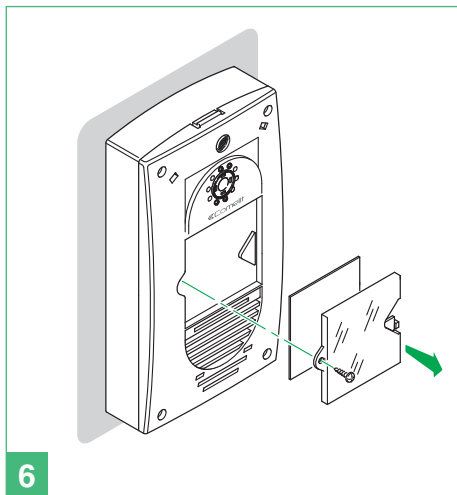
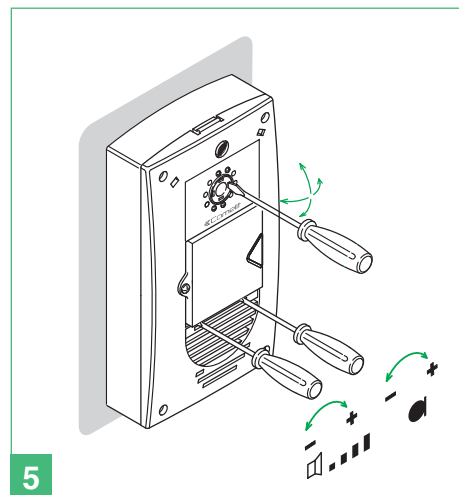
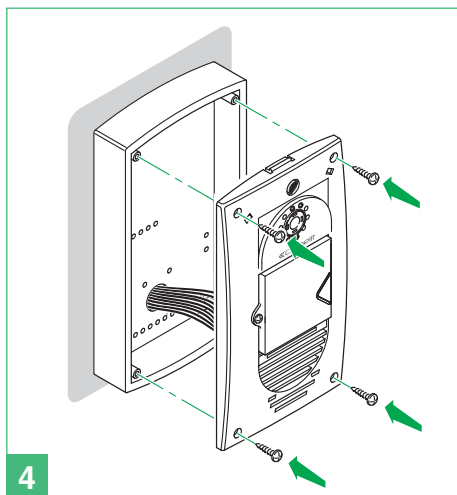
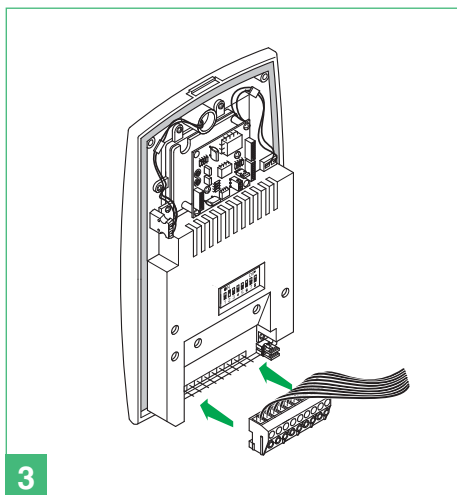
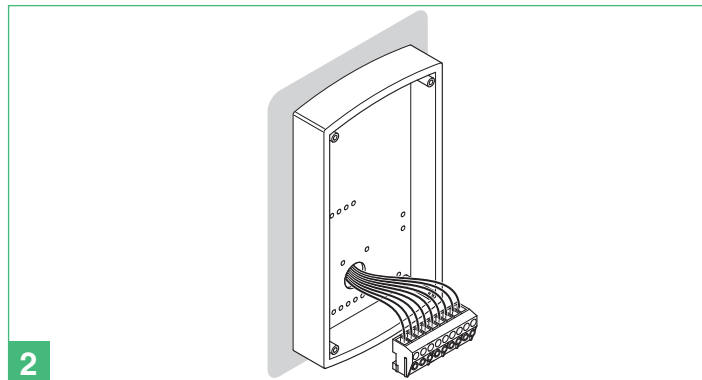
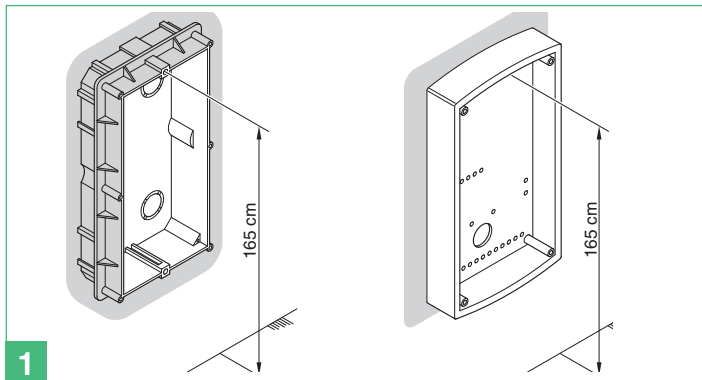
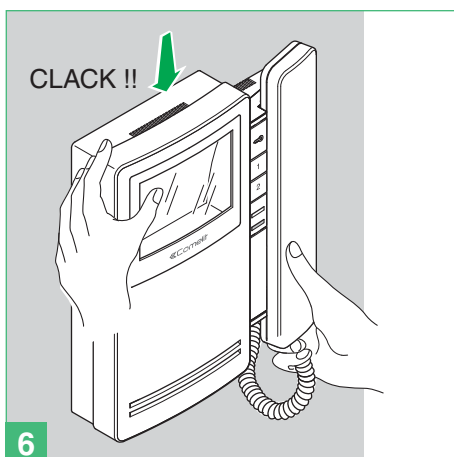
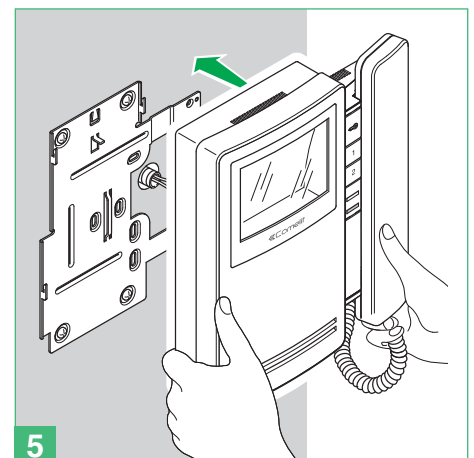
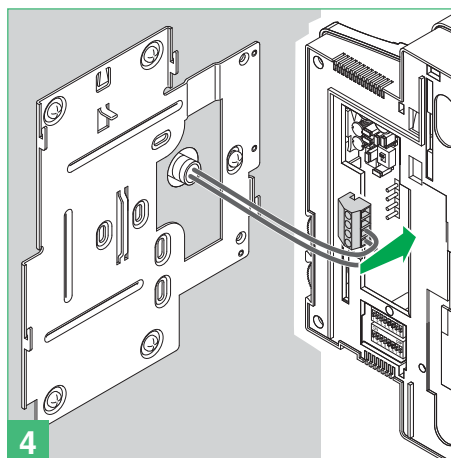
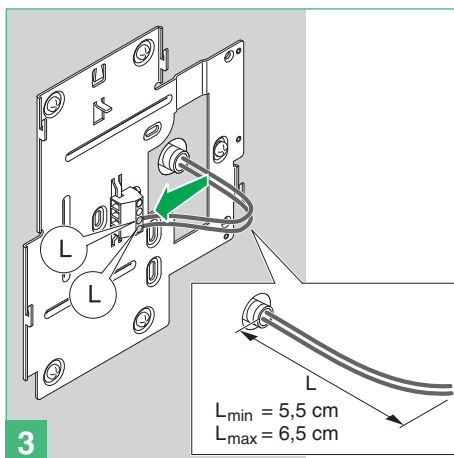
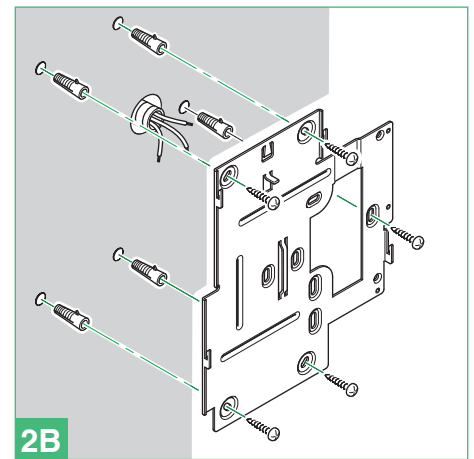
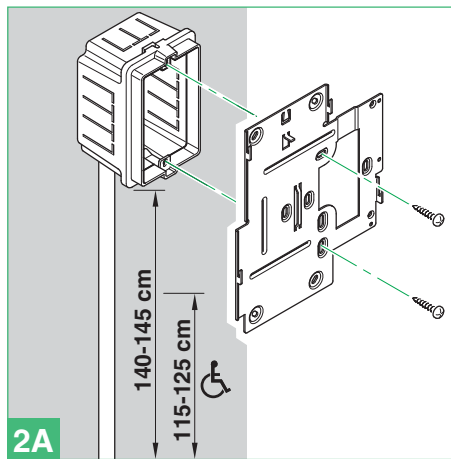
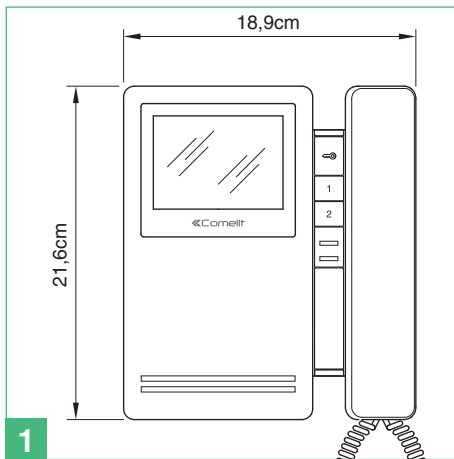

Fig 4 Prima di fissare le 4 viti assicurarsi che non si voglia procedere con la programmazione delle funzioni speciali a pag. 17.

Fig 5 Allentare leggermente le quattro viti per sbloccare l'orientamento della telecamera.

Montaggio posto interno Magis



Sgancio del monitor

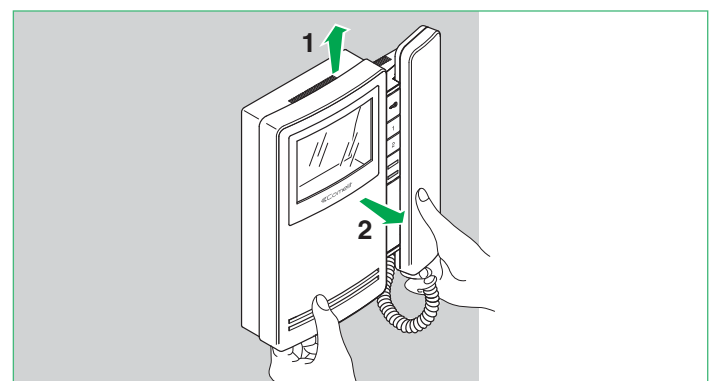

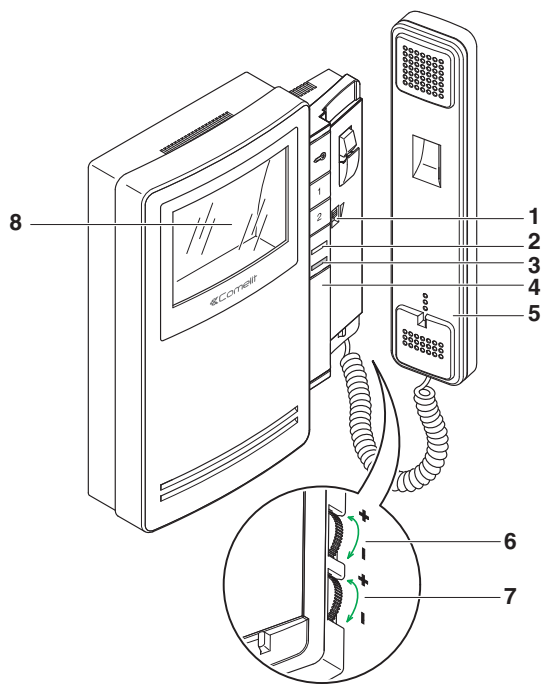

Descrizione monitor:

- 1 Regolazione volume chiamata / selettore funzione Privacy (per servizio Privacy si intende l'esclusione della chiamata dal posto esterno e da citofoni o videocitofoni intercomunicanti; l'attivazione della funzione privacy è evidenziata dalla comparsa di un indicatore rosso a lato del selettore).
- 2 Led di segnalazione impianto occupato/funzione dottore attiva/porta aperta.
- 3 Indicatore rosso - privacy attivata.
- 4 Spazio alloggiamento pulsanti supplementari con accessorio Art. 6433, Art. 6434.
- 5 Cornetta Monitor (sollevare la cornetta per iniziare la comunicazione)
- 6 Manopola regolazione intensità colore.
 - ▶ Per aumentare il valore ruotare in senso antiorario.
- 7 Manopola regolazione luminosità.
 - ▶ Per aumentare il valore ruotare in senso antiorario.
- 8 Schermo a colori 3,5".

Descrizione pulsanti:

- ☞ Pulsante apriporta.
- 1 Tasto 1 attuatore generico (programmabile).
- 2 Tasto 2 autoaccensione (programmabile).

Descrizione monitor

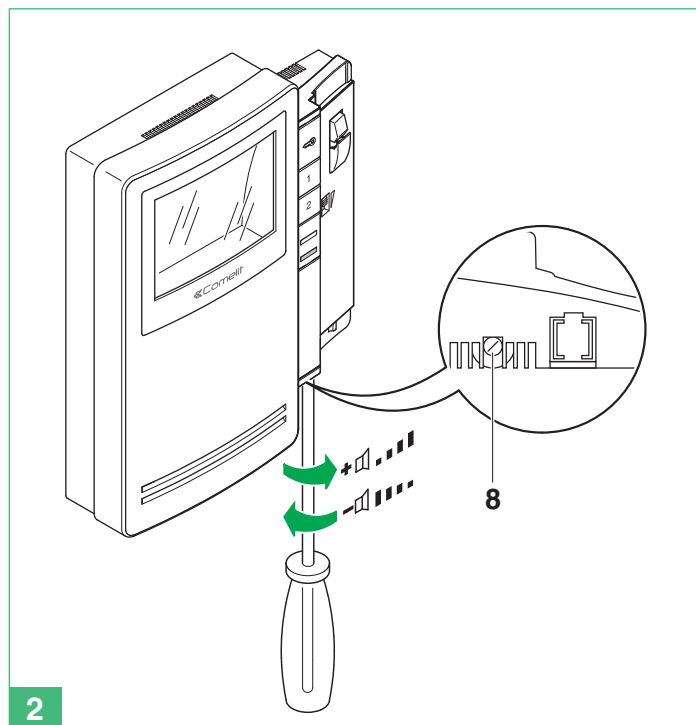
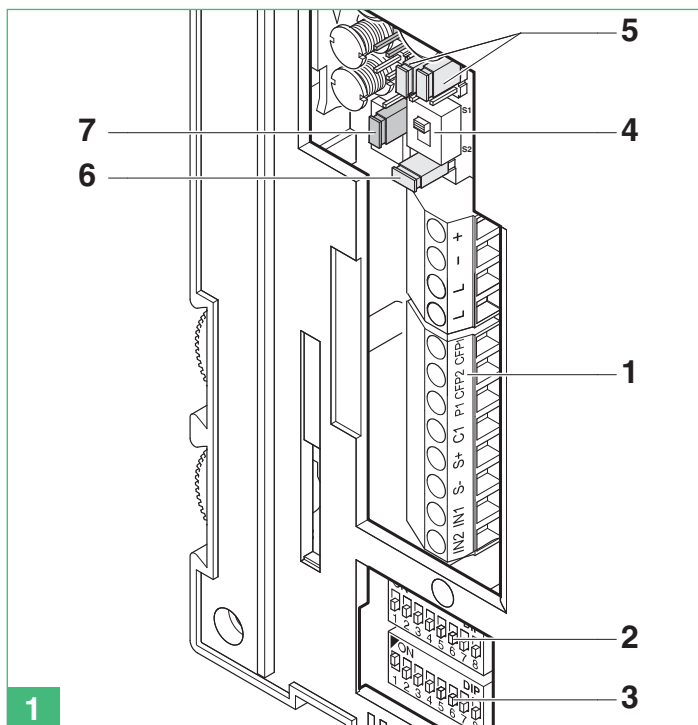

- 1 Morsettiera per connessione impianto:
 - + - Morsetti per alimentazione.
 - L L Morsetti di connessione linea Bus.
 - CFP1 CFP2 Ingresso chiamata da piano.
 - P1 C1 Morsetti Pulsante 1 per servizi vari.
 - Per avere un contatto C.NO. (24V-100mA max) spostare in posizione B i jumper CV3 e CV4.**
 - S+ S- Morsetti per dispositivo ripetizione di chiamata.
 - IN1 IN2 Ingresso LED (programmabile).
- 2 S1 Micro-interruttori per programmazione codice utente.
- 3 S2 Micro-interruttori per programmazione pulsanti e funzioni (identificato da angolo rosso):
 - DIP 1-2-3-4 per programmazione funzioni pulsanti.
 - DIP 5-6 accesso programmazioni.
 - DIP 7 per gestione tensione di alimentazione (vedere schemi e varianti da pag. 114) default = OFF.

- DIP 8:
 - ON staffa secondaria.
 - OFF staffa principale (default).
- 4 SW3 Selettore per modalità Simplebus 1 (S1- default) o Simplebus 2 (S2).
- 5 CV3 CV4 Jumper per liberare il pulsante 1 (contatto C.NO. 24V-100mA max).
 - A pulsante 1 attuatore generico (default) o programmabile.
 - B pulsante 1 per usi vari.
- 6 CV5 Jumper chiusura video.
- 7 CV6 selettore per utilizzo ingresso IN 1 (vedi pag. 124).
- 8 Regolazione volume altoparlante (solo per settaggio fonica intercomunicante).

Non è utilizzabile per sfruttare la funzione intercomunicante.
Il citofono va montato sempre utilizzando l'Art. 1214/2C come mostrato nello schema di collegamento MSK/FC a pag. 122.

- 1 Indicatore funzione Privacy.
- 2 Selettore suoneria/servizio Privacy a 3 posizioni:
Posizione alto: Suoneria volume massimo.
Posizione centrale: Suoneria volume medio.
Posizione basso: Attivazione funzione Privacy.
(Per servizio Privacy si intende l'esclusione della chiamata dal posto esterno e centralino; l'attivazione della funzione Privacy è evidenziata dalla comparsa di un indicatore rosso in alto a destra).
- 3 Trimmer regolazione volume microfono.
- 4 Micro-interruttori per impostazione codice utente.
- 5 Morsetti connessione impianto:
L L Connessione alla linea bus.
CFP CFP Ingresso chiamata da piano.
P1 C1 Morsetti Pulsante P1 per servizi vari (contatto C. NO. 24V-100mA max) (rimuovere CV1 e CV2, vedi variante SB/X3 pag. 122).
S+ S- Morsetti per dispositivo ripetizione di chiamata.
- 6 **CV1 CV2 Jumper da rimuovere per avere contatto pulito C.NO. sul pulsante P1.**
- 7A/7B **JP1** Jumper per selezionare la funzione Chiamata centralino (posizione C)/Attuatore generico (posizione A) del pulsante P1.

Descrizione pulsanti:

- ☞ Pulsante Apriporta.
- P1** Pulsante P1 chiamata centralino/attuatore generico/pulsante per servizi vari presente in morsettiera (P1 C1).

Pulire con un panno inumidito con acqua. Evitare Alcool e altri prodotti aggressivi.

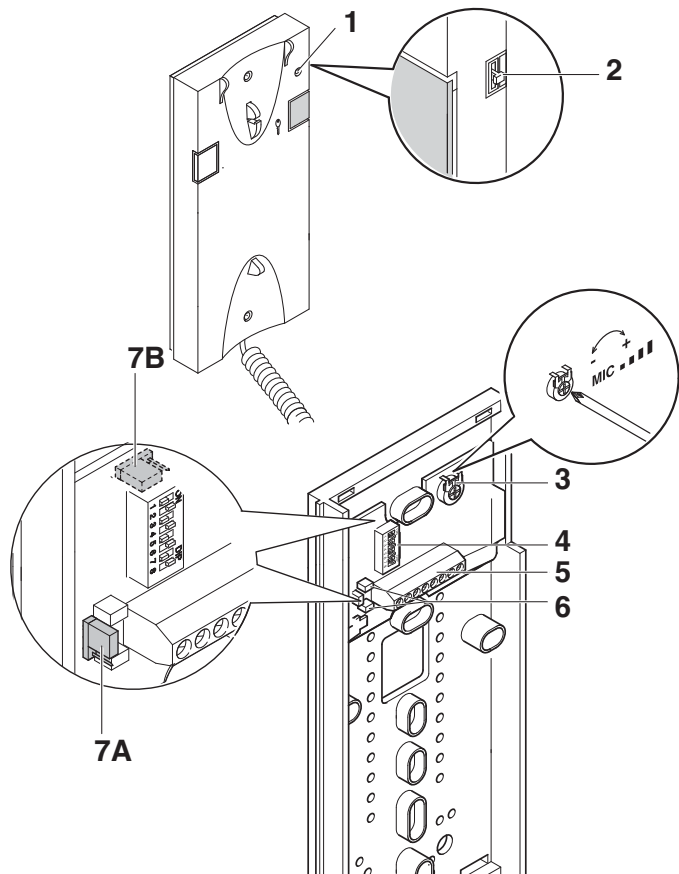

Installazione citofono Art. 2608

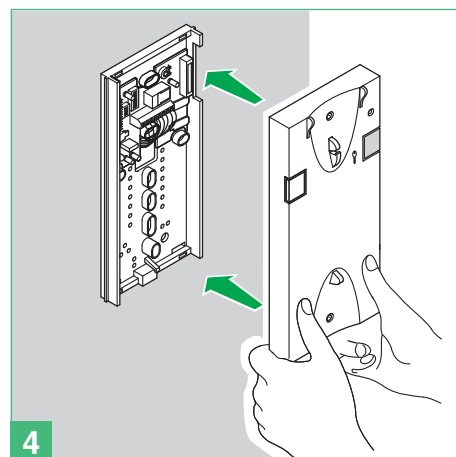
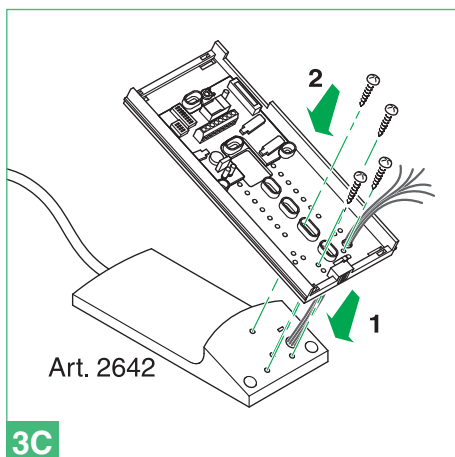
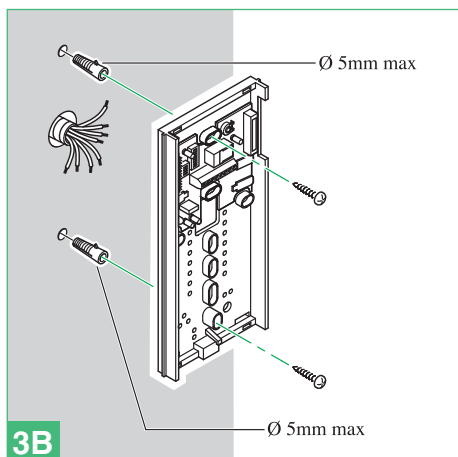
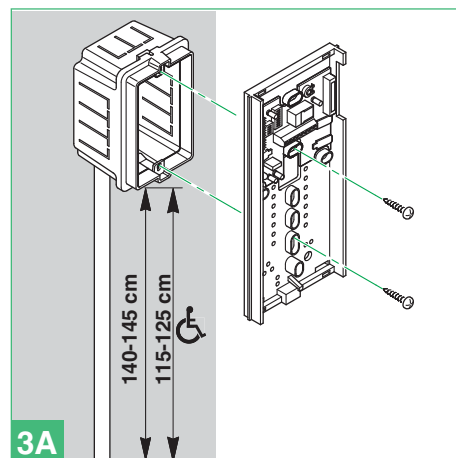
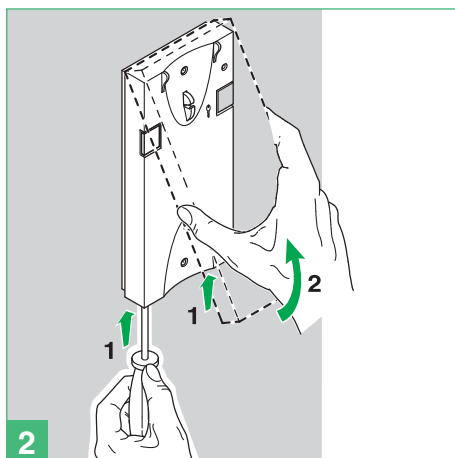
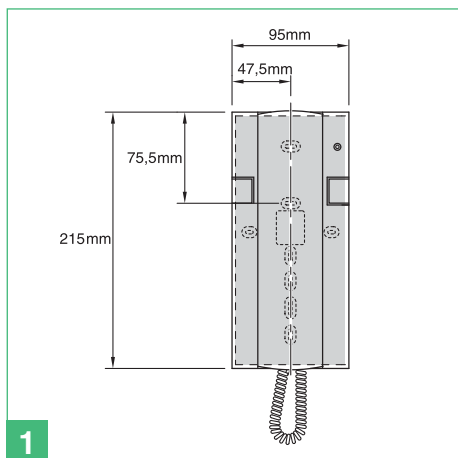

Indicazioni generali di installazione e funzionamento

La distanza massima totale tra il posto esterno e il monitor più lontano è 400 m (con amplificatore Art. 4833C).

La somma totale del numero di posti interni con stesso codice utente e del numero di dispositivi di ripetizione chiamata collegati ai suddetti posti interni non può superare il numero di 4.

Connettere un solo dispositivo di ripetizione chiamata per ogni posto interno.

La distanza MAX del collegamento tra posto interno e dispositivo di ripetizione chiamata è di 20m; utilizzare cavo schermato per il collegamento e non far passare i cavi in prossimità di carichi induttivi pesanti o cavi di alimentazione (230V / 400V).

Tabella distanze di funzionamento

		A/G MAX	B/E MAX	C MAX	D MAX	F MAX	Art. 1216
Comelit Art. 4577 1 mm ² (Ø 1,2 mm AWG 17)		50 m (165 feet)	50 m (165 feet)	200 m (655 feet)	100 m (330 feet)	150 m (495 feet)	
Comelit Art. 4576-4578	0,5 mm ² (Ø 0,8 mm AWG 20) bus		25 m (85 feet)	200 m (655 feet)	100 m (330 feet)	150 m (495 feet)	
	1,5 mm ² (Ø 1,4 mm AWG 15) power	75 m (245 feet)	100 m (330 feet)				
UTP5 cat. 5 0,2 mm ² (Ø 0,5 mm AWG 24)				190 m (625feet)	60 m (195 feet)	150 m (495 feet)	
0,28 mm ² (Ø 0,6 mm AWG 23)		5 m (15 feet)		190 m (625 feet)	60 m (195 feet)	150 m (495 feet)	
0,5 mm ² (Ø 0,8 mm AWG 20)		25 m (85 feet)	25 m (85 feet)	190 m (625 feet)	60 m (195 feet)	150 m (495 feet)	
1 mm ² (Ø 1,2 mm AWG 17)		50 m (165 feet)	50 m (165 feet)	190 m (625 feet)	60 m (195 feet)	150 m (495 feet)	
1 mm ² (Ø 1,2 mm AWG 17)		50 m (165 feet)	50 m (165 feet)	120 m (395 feet)	40 m (130 feet)	100 m (330 feet)	
1,5 mm ² (Ø 1,4 mm AWG 15)		75 m (245 feet)	100 m (330 feet)	190 m (625 feet)	60 m (195 feet)	150 m (495 feet)	
2,5 mm ² (Ø 1,8 mm AWG 13)		100 m (330 feet)	150 m (495 feet)	190 m (625 feet)	60 m (195 feet)	150 m (495 feet)	

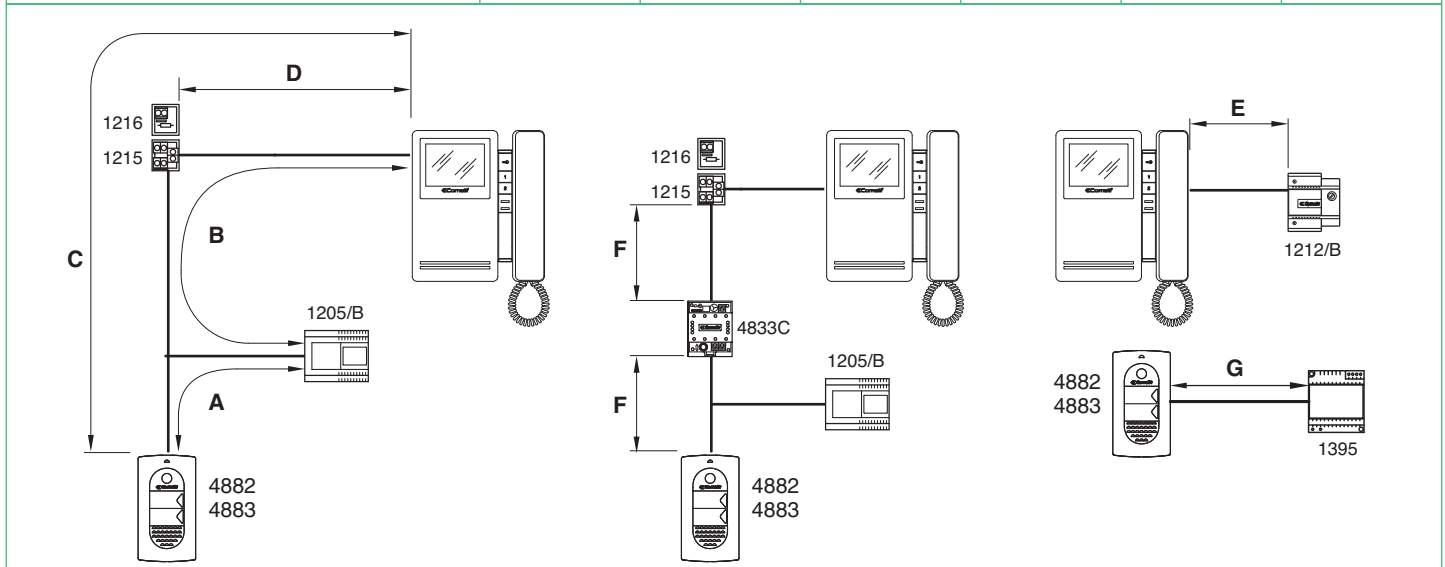

Funzionamento



In caso di cortocircuito persistente sulla linea bus il posto esterno emette un tono di segnalazione intermittente.

Il visitatore quando preme il tasto di chiamata accende l'illuminazione del soggetto, aziona la suoneria interna di chiamata (se la funzione privacy non è abilitata) e fa apparire l'immagine sul/sui monitor principale/i per circa 60".

La durata massima della conversazione tra posto esterno e posto interno è di 90".

Al posto esterno si ha un tono di avvenuta chiamata; se in impianti con 2 o più ingressi all'atto della chiamata, il posto esterno emette un tono di occupato invece che la replica della suoneria, significa che un'altra comunicazione è già in atto verso un altro posto esterno.

Per la programmazione di indirizzi utente diversi da quelli impostati di fabbrica (1 e 2) vedi pag. 9.

Per le funzionalità intercomunicanti del Sistema Magis Kit vedi pag. 11.

Descrizione impostazioni e funzionamento pulsanti

Impostazione monitor Art. 6402E e citofono Art. 2608

Posizione dei microinterruttori del monitor Art.6402E

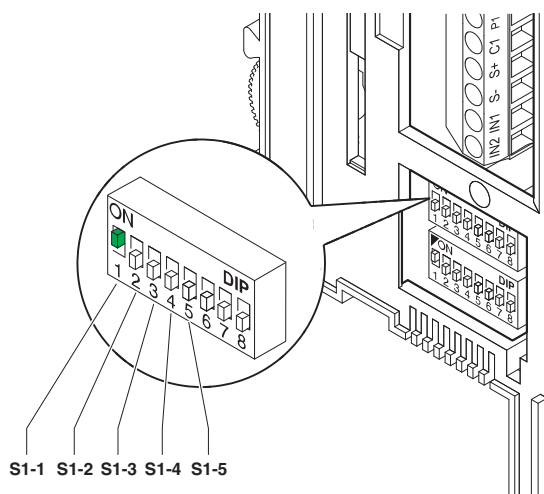

► Sui citofoni Art. 2608, Art. 2610 e Art. 2628 posizionare i dip **S1-6, S1-7, S1-8** su **OFF**

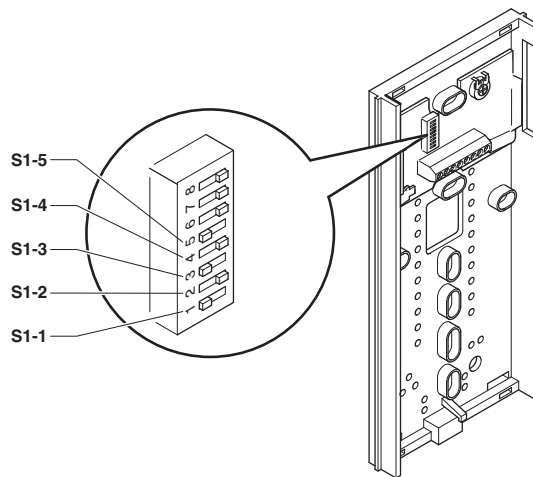

I valori di **S1-1, S1-2, S1-3, S1-4** e **S1-5** definiscono l'indirizzo di chiamata del monitor e dei citofoni come riportato nella seguente tabella.

TAB. A Indirizzi di montante

Codice	S1
1	

Descrizione funzione Pulsanti

☞ **Apriporta:** La pressione del Pulsante Apriporta attiva la serratura connessa al posto esterno.

Attuatore: La pressione del Pulsante 1 impostato nella modalità Attuatore permette l'attivazione dell'Art. 1256 che può essere utilizzato ad esempio per attivare l'apertura di cancelli, porte basculanti o per l'attivazione del modulo telecamere cicliche Art. 1259/A.

Pulsante Libero: L'indicazione Pulsante libero indica la possibilità di utilizzare il Pulsante 1 come contatto C.NO. in morsettiera mediante opportune impostazioni come illustrato nella variante SB2/AAM2 pag.125.

Autoaccensione / Richiesta Video:

- ✓ L'autoaccensione può essere disabilitata.
- ✓ L'autoaccensione è possibile solo con impianto a riposo.
- ✓ L'autoaccensione è consigliata solo per impianti con 1 o 2 ingressi.

La pressione del Pulsante 2 permette di visualizzare sullo schermo del Monitor l'immagine trasmessa dal posto esterno anche se non è stata effettuata nessuna chiamata.

In impianti dotati di due posti esterni, è possibile visualizzare alternativamente l'immagine da un posto esterno o dall'altro (funzione "bascula") con successive pressioni del Pulsante. L'autoaccensione è possibile solo ad impianto libero.

Su monitor secondari (**S2** DIP8 ON) il pulsante 2 ha anche la funzione di richiesta video, permette di accendere un monitor in seguito a una chiamata da posto esterno.

Abilitazione:

- premere il pulsante dedicato all'autoaccensione del monitor per un tempo superiore a 4 sec.
- » suoneria di conferma.

Disabilitazione:

- premere il pulsante dedicato all'autoaccensione per un tempo superiore a 4 sec.
- » 4 toni di conferma.

Accensione:

- premere e rilasciare immediatamente il pulsante dedicato (pulsante 2 - se mantenute le impostazioni di fabbrica).

Chiamata a centralino

La pressione del pulsante impostato in questa modalità permette di inviare una chiamata al centralino di portineria.

Chiamata intercomunicante monofamiliare

Questa funzione permette di inviare una chiamata agli altri apparecchi (videocitofoni e/o citofoni) impostati sullo stesso indirizzo di chiamata.

- Il ricevente della chiamata alzando la cornetta entra in comunicazione con il chiamante. Riagganciando la cornetta la comunicazione viene terminata.

Una chiamata intercomunicante non è prioritaria rispetto ad una conversazione/chiamata con il posto esterno.

In questo caso, durante un tentativo di chiamata intercomunicante, il LED di segnalazione lampeggerà per alcuni secondi per segnalare che il sistema è occupato.

Chiamata da posto esterno

Una chiamata da posto esterno è sempre prioritaria rispetto a una comunicazione intercomunicante (L'attivazione della comunicazione con il posto esterno interrompe la conversazione intercomunicante precedentemente in corso). In questo caso gli utenti che si trovano già in conversazione sentiranno in cornetta un tono simile a quello di chiamata se quest'ultima è indirizzata a loro o un triplice tono di segnalazione in caso contrario.

- Per rispondere alla chiamata da posto esterno è sufficiente sollevare la cornetta da qualunque apparecchio libero o riagganciare e sollevare la cornetta da un apparecchio impegnato nella comunicazione intercomunicante.

Dottore

Questa funzione permette l'azionamento automatico dell'apriporta su chiamata da posto esterno all'indirizzo del posto interno su cui la funzione è stata attivata.

Abilitazione/disabilitazione:

- tenere premuto per 2 sec. il pulsante impostato per tale funzione
- » a funzione attivata il led di segnalazione rimane acceso.

Monitor supplementari principali o secondari

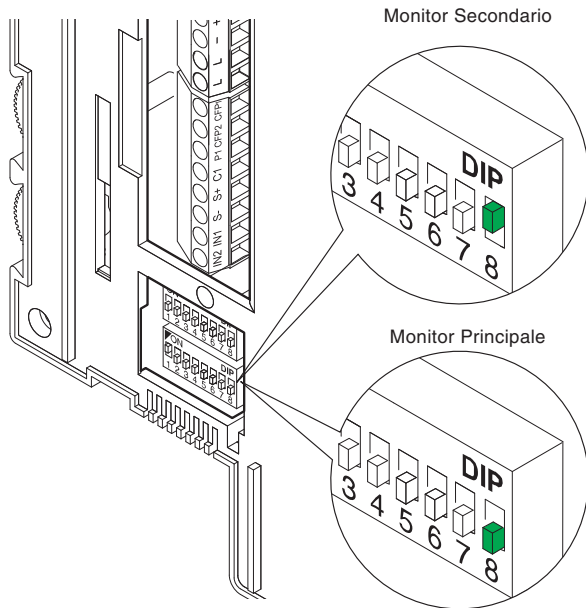

L'impostazione del DIP 8 di S2 definisce se la staffa in oggetto verrà gestita come principale (P) o secondaria (S).
 Il posto esterno può gestire fino a un massimo di 4 videocitofoni o citofoni per pulsante di chiamata.

Nella configurazione classica del Magis Kit si possono avere al massimo 2 videocitofoni principali e 2 videocitofoni secondari per pulsante di chiamata tutti alimentati dallo stesso **Art. 1205/B**.

È possibile gestire fino a 3 videocitofoni principali all'interno della stessa unità familiare (cioè impostati sul medesimo codice utente). In questa particolare configurazione, i videocitofoni principali aggiuntivi dovranno essere alimentati dall'apposito **Art. 1212/B** (vedi variante **MSK/HCA, MSK/IC** pag. 118, 119).

Quando dal posto esterno si effettua una chiamata, il monitor che si accende è il videocitofono principale.

Gli eventuali monitor secondari della medesima unità familiare resteranno spenti.

Rispondendo alla chiamata del posto esterno da un videocitofono secondario, l'immagine viene automaticamente visualizzata sul monitor.

A questo punto il monitor del videocitofono principale si spegne e l'immagine compare sul monitor del videocitofono su cui viene premuto il pulsante 2 - autoaccensione/riciesta video.

Per visualizzare l'immagine senza attivare la fonica con il posto esterno, premere il pulsante 2- autoaccensione/riciesta video.

Configurazioni pulsanti di default

DIP S2								con Art. 6433, 6434			
DIP 1	DIP 2	DIP 3	DIP 4	P1	P2	🔑	☎️	P3	P4	P5	P6
0	0	0	0	CCS	AI			ACT	D	PAN	K
1	0	0	0	ACT	AI			INT	INTb	D	CCS
0	1	0	0	INT	AI			INTb	ACT	CCS	CCP
1	1	0	0	ACT	CCS			CCP	PAN	K	D
0	0	1	0	ACT	ACT	ACT		ACT	ACT	ACT	ACT
1	0	1	0	INT	ACT			CCS	CCP	INTb	PAN
0	1	1	0	AI	D			K	CCS	CCP	INTb
1	1	1	0	INTb	INT			AI	INT	PAN	D
0	0	0	1	CCS	PAN			D	AI	INT	INTb
1	0	0	1	K	CCS			PAN	CCP	AI	INT
0	1	0	1	CCP	K			PAN	ACT	INT	AI
1	1	0	1	PAN	CCP			CCS	K	ACT	D
0	0	1	1	D	INTb			INT	ACT	AI	CCS
1	0	1	1	INT	INT			INT	INT	INT	INT
0	1	1	1	NULL	NULL	NULL	NULL	NULL	NULL	NULL	NULL
1	1	1	1								

Legenda

🔑	Apriporta	CCS	Chiamata a centralino	INTb	Intercomunicante bifamiliare - solo per KIT
☎️	Fonica	K	Chiamata citofono guardiano	NULL	Nessuna funzione
ACT	Attuatore	D	Dottore	PROG	Funzioni programmate, vedi pag. 10-11-12-13. In questa impostazione dei dip i pulsanti gestiscono le funzioni programmate; i pulsanti NON programmati gestiscono le funzioni riferite alla riga 0000
AI	Autoaccensione	PAN	Panico		
CCP	Chiamata a centralino principale	INT	Intercomunicante programmabile generale o selettivo - di serie chiamata monofamiliare per KIT e Simplebus Top		



Avvertenze generali programmazione pulsanti

Nel caso le configurazioni di default (vedi tabella pag. 10) non rispecchino le necessità è possibile programmare diversamente i pulsanti secondo le procedure descritte di seguito.

Al termine posizionare i DIP 1-2-3-4 di S2 in combinazione 1111 (settaggio PROG nelle tabelle di configurazione pag. 10, 11, 12, 13). In questa

impostazione dei dip i pulsanti gestiscono le funzioni programmate; i pulsanti NON programmati gestiscono le funzioni riferite alla riga 0000 (vedi tabella pag. 10). Ripristinare su S1 l'impostazione del codice utente, vedi tabella A pag. 9.

Programmazioni pulsanti per attuatore generico o indirizzato

DIP S2				con Art. 6433, 6434								DIP S1
DIP 1	DIP 2	DIP 3	DIP 4	P1	P2			P3	P4	P5	P6	INDIRIZZO 1 2 3 4 5 6 7 8
0	0	0	0							ACT		
1	0	0	0	ACT								
0	1	0	0						ACT			
1	1	0	0	ACT								
0	0	1	0	ACT	ACT	ACT		ACT	ACT	ACT	ACT	
1	0	1	0		ACT							
0	1	1	0									
1	1	1	0									
0	0	0	1									
1	0	0	1									
0	1	0	1						ACT			
1	1	0	1							ACT		
0	0	1	1									
1	0	1	1						ACT			
0	1	1	1									
1	1	1	1									

Esempio:

su monitor con codice utente 5 programmazione P1= attuatore generico, P2= attuatore indirizzato a codice 125.

1. Posizionare DIP 5-6 di S2 in combinazione 01.

» Il led (verde) lampeggia.

2. Consultare la tabella pag. 11 e scegliere una combinazione in cui compare la funzione attuatore (ACT) per i pulsanti che si intendono programmare.

ES: per P1= attuatore generico impostare DIP 1-2-3-4 di S2 in combinazione 1000 o 1100 o 0010 (P1=ACT), impostare DIP di S1 in combinazione 11111111, passare al punto 3.

ES: per P2= attuatore indirizzato a codice 125 impostare DIP 1-2-3-4 di S2 in combinazione 0010 o 1010 (P2=ACT), impostare S1 con indirizzo 125 secondo tabella C pag. 13, passare al punto 3.

3. Premere e rilasciare il pulsante a cui si vuole associare la funzione.

» il led (verde) si accende.

» tono di conferma in cornetta.

4. Per uscire dalla programmazione posizionare i DIP 5-6 di S2 in combinazione 00.

» il led (verde) si spegne.

5. Al termine della programmazione posizionare i DIP 1-2-3-4 di S2 in combinazione 1111. Ripristinare su S1 l'impostazione del codice utente, vedi tabella A pag. 9.

Programmazioni per chiamata intercomunicante



Intercomunicante generale e selettivo **NON** sono compatibili sullo stesso montante.

Programmazione/cancellazione indirizzo intercomunicante (solo per intercomunicante selettivo)

1)	2)						3)
S1	DIP 1	DIP 2	DIP 3	DIP 4	DIP 5	DIP 6	S2
Programmazione; impostare codice, TAB. B pag. 11	0	0	0	1	1	1	
Cancellazione 	1	1	1	1	1	1	 2 sec



Prendere nota dell'impostazione di S2, S1 e ripristinarla al termine della programmazione.

TAB. B Indirizzi intercomunicante selettivo

Codice / Code	Dip switch ON	S1	Codice / Code	Dip switch ON	S1	Codice / Code	Dip switch ON	S1
1	1		4	4		7	7	
2	2		5	5		8	8	
3	3		6	6				

È necessario impostare l'indirizzo intercomunicante a tutti i posti interni del montante.

È possibile associare lo stesso indirizzo intercomunicante a un max di 3 posti interni.

Per la chiamata di gruppo selezionare contemporaneamente i codici intercomunicanti desiderati (max 3).

Programmazioni pulsanti per chiamata intercomunicante

DIP S2				con Art. 6433, 6434				DIP S1					
DIP 1	DIP 2	DIP 3	DIP 4	P1	P2			P3	P4	P5	P6	INDIRIZZO 	
0	0	0	0										
1	0	0	0					INT	INTb				
0	1	0	0	INT				INTb					
1	1	0	0										
0	0	1	0										
1	0	1	0	INT						INTb			
0	1	1	0								INTb		
1	1	1	0	INTb	INT				INT				
0	0	0	1							INT	INTb		
1	0	0	1								INT		
0	1	0	1							INT			
1	1	0	1										
0	0	1	1		INTb			INT					
1	0	1	1	INT	INT			INT	INT	INT	INT		
0	1	1	1										
1	1	1	1										
PROG													

Esempio 1 - Intercomunicante selettivo

su monitor con codice utente 1 e indirizzo intercomunicante 1 programmazione P3= intercomunicante selettivo a indirizzo 2, P4= intercomunicante selettivo a indirizzo 3.

Esempio 2 - Intercomunicante KIT

(intercomunicante tra 2 indirizzi contigui nel range da 1 a 30 di cui il primo dispari):

su monitor con codice utente 1 programmazione P3= chiamata generale interna, P4= intercomunicante bifamiliare a indirizzo 2.

1. Posizionare DIP 5-6 di S2 in combinazione 01.

» il led (verde) lampeggia.

2. Consultare la tabella pag. 12 e scegliere una combinazione in cui compare la funzione intercomunicante (INT o INTb) per i pulsanti che si intendono programmare.

ES1: per P3= intercomunicante selettivo impostare DIP 1-2-3-4 di S2 in combinazione 1000 o 0011 o 1011 (P3=INT), impostare S1 con indirizzo 2 secondo **tabella B** pag. 11, passare al punto 3.

ES1: per P4= intercomunicante selettivo impostare DIP 1-2-3-4 di S2 in combinazione 1110 o 1011 (P4=INT), impostare S1 con indirizzo 3 secondo **tabella B** pag. 11, passare al punto 3.

ES2: per P3= chiamata generale interna e P4= intercomunicante bifamiliare impostare DIP 1-2- 3-4 di S2 in combinazione 1000 (P3=INT, P4=INTb), impostare S1 con codice utente 1 secondo **tabella A** pag. 9, passare al punto 3.

3. Premere e rilasciare il pulsante a cui si vuole associare la funzione.

» il led (verde) si accende.

» tono di conferma in cornetta.

4. Per uscire dalla programmazione posizionare i DIP 5-6 di S2 in combinazione 00.

» il led (verde) si spegne.

5. Al termine della programmazione posizionare i DIP 1-2-3-4 di S2 in combinazione 1111. Ripristinare su S1 l'impostazione del codice utente, vedi **tabella A** pag. 9.

Programmazioni pulsanti per altre funzioni

DIP S2				con Art. 6433, 6434				DIP S1					
DIP 1	DIP 2	DIP 3	DIP 4	P1	P2			P3	P4	P5	P6	PROG	
0	0	0	0	CCS	AI				D	PAN	K		
1	0	0	0		AI					D	CCS		
0	1	0	0		AI					CCS	CCP		
1	1	0	0		CCS			CCP	PAN	K	D		
0	0	1	0										
1	0	1	0										
0	1	1	0	AI	D			CCS	CCP	CCP	PAN		
1	1	1	0					K	CCS	PAN	D		
0	0	0	1	CCS	PAN			AI	AI				
1	0	0	1	K	CCS			PAN	CCP	AI			
0	1	0	1	CCP	K			PAN			AI		
1	1	0	1	PAN	CCP			CCS	K		D		
0	0	1	1	D						AI	CCS		
1	0	1	1										
0	1	1	1	NULL	NULL	NULL	NULL	NULL	NULL	NULL	NULL		NULL
1	1	1	1										

Legenda

	Apriporta	CCS	Chiamata a centralino	NULL	Nessuna funzione
	Fonica	K	Chiamata citofono guardiano	PROG	Funzioni programmate
AI	Autoaccensione	D	Dottore		
CCP	Chiamata a centralino principale	PAN	Panico		

Esempio:

su monitor con codice utente 5 programmazione P5= autoaccensione, P6= chiamata a centralino.

1. Posizionare DIP 5-6 di S2 in combinazione 01.

» il led (verde) lampeggia.

2. Consultare la tabella pag. 12 e scegliere una combinazione in cui compaiono le funzioni desiderate/necessarie per i pulsanti che si intendono programmare.

ES: per P5= autoaccensione P6= chiamata a centralino impostare DIP 1-2-3-4 di S2 in combinazione 0011 (P5=AI, P6=CCS).

3. Premere e rilasciare il pulsante a cui si vuole associare la funzione.

» il led (verde) si accende

» tono di conferma in cornetta

4. Per uscire dalla programmazione posizionare i DIP 5-6 di S2 in combinazione 00.

» il led (verde) si spegne

5. Al termine della programmazione posizionare i DIP 1-2-3-4 di S2 in combinazione 1111.





TAB. C Indirizzi di montante

Code	Dip switch ON	Code	Dip switch ON	Code	Dip switch ON	Code	Dip switch ON	Code	Dip switch ON	Code	Dip switch ON	Code	Dip switch ON	Code	Dip switch ON
1	1	31	1,2,3,4,5	61	1,3,4,5,6	91	1,2,4,5,7	121	1,4,5,6,7	151	1,2,3,5,8	181	1,3,5,6,8	211	1,2,5,7,8
2	2	32	6	62	2,3,4,5,6	92	3,4,5,7	122	2,4,5,6,7	152	4,5,8	182	2,3,5,6,8	212	3,5,7,8
3	1,2	33	1,6	63	1,2,3,4,5,6	93	1,3,4,5,7	123	1,2,4,5,6,7	153	1,4,5,8	183	1,2,3,5,6,8	213	1,3,5,7,8
4	3	34	2,6	64	7	94	2,3,4,5,7	124	3,4,5,6,7	154	2,4,5,8	184	4,5,6,8	214	2,3,5,7,8
5	1,3	35	1,2,6	65	1,7	95	1,2,3,4,5,7	125	1,3,4,5,6,7	155	1,2,4,5,8	185	1,4,5,6,8	215	1,2,3,5,7,8
6	2,3	36	3,6	66	2,7	96	6,7	126	2,3,4,5,6,7	156	3,4,5,8	186	2,4,5,6,8	216	4,5,7,8
7	1,2,3	37	1,3,6	67	1,2,7	97	1,6,7	127	1,2,3,4,5,6,7	157	1,3,4,5,8	187	1,2,4,5,6,8	217	1,4,5,7,8
8	4	38	2,3,6	68	3,7	98	2,6,7	128	8	158	2,3,4,5,8	188	3,4,5,6,8	218	2,4,5,7,8
9	1,4	39	1,2,3,6	69	1,3,7	99	1,2,6,7	129	1,8	159	1,2,3,4,5,8	189	1,3,4,5,6,8	219	1,2,4,5,7,8
10	2,4	40	4,6	70	2,3,7	100	3,6,7	130	2,8	160	6,8	190	2,3,4,5,6,8	220	3,4,5,7,8
11	1,2,4	41	1,4,6	71	1,2,3,7	101	1,3,6,7	131	1,2,8	161	1,6,8	191	1,2,3,4,5,6,8	221	1,3,4,5,7,8
12	3,4	42	2,4,6	72	4,7	102	2,3,6,7	132	3,8	162	2,6,8	192	7,8	222	2,3,4,5,7,8
13	1,3,4	43	1,2,4,6	73	1,4,7	103	1,2,3,6,7	133	1,3,8	163	1,2,6,8	193	1,7,8	223	1,2,3,4,5,7,8
14	2,3,4	44	3,4,6	74	2,4,7	104	4,6,7	134	2,3,8	164	3,6,8	194	2,7,8	224	6,7,8
15	1,2,3,4	45	1,3,4,6	75	1,2,4,7	105	1,4,6,7	135	1,2,3,8	165	1,3,6,8	195	1,2,7,8	225	1,6,7,8
16	5	46	2,3,4,6	76	3,4,7	106	2,4,6,7	136	4,8	166	2,3,6,8	196	3,7,8	226	2,6,7,8
17	1,5	47	1,2,3,4,6	77	1,3,4,7	107	1,2,4,6,7	137	1,4,8	167	1,2,3,6,8	197	1,3,7,8	227	1,2,6,7,8
18	2,5	48	5,6	78	2,3,4,7	108	3,4,6,7	138	2,4,8	168	4,6,8	198	2,3,7,8	228	3,6,7,8
19	1,2,5	49	1,5,6	79	1,2,3,4,7	109	1,3,4,6,7	139	1,2,4,8	169	1,4,6,8	199	1,2,3,7,8	229	1,3,6,7,8
20	3,5	50	2,5,6	80	5,7	110	2,3,4,6,7	140	3,4,8	170	2,4,6,8	200	4,7,8	230	2,3,6,7,8
21	1,3,5	51	1,2,5,6	81	1,5,7	111	1,2,3,4,6,7	141	1,3,4,8	171	1,2,4,6,8	201	1,4,7,8	231	1,2,3,6,7,8
22	2,3,5	52	3,5,6	82	2,5,7	112	5,6,7	142	2,3,4,8	172	3,4,6,8	202	2,4,7,8	232	4,6,7,8
23	1,2,3,5	53	1,3,5,6	83	1,2,5,7	113	1,5,6,7	143	1,2,3,4,8	173	1,3,4,6,8	203	1,2,4,7,8	233	1,4,6,7,8
24	4,5	54	2,3,5,6	84	3,5,7	114	2,5,6,7	144	5,8	174	2,3,4,6,8	204	3,4,7,8	234	2,4,6,7,8
25	1,4,5	55	1,2,3,5,6	85	1,3,5,7	115	1,2,5,6,7	145	1,5,8	175	1,2,3,4,6,8	205	1,3,4,7,8	235	1,2,4,6,7,8
26	2,4,5	56	4,5,6	86	2,3,5,7	116	3,5,6,7	146	2,5,8	176	5,6,8	206	2,3,4,7,8	236	3,4,6,7,8
27	1,2,4,5	57	1,4,5,6	87	1,2,3,5,7	117	1,3,5,6,7	147	1,2,5,8	177	1,5,6,8	207	1,2,3,4,7,8	237	1,3,4,6,7,8
28	3,4,5	58	2,4,5,6	88	4,5,7	118	2,3,5,6,7	148	3,5,8	178	2,5,6,8	208	5,7,8	238	2,3,4,6,7,8
29	1,3,4,5	59	1,2,4,5,6	89	1,4,5,7	119	1,2,3,5,6,7	149	1,3,5,8	179	1,2,5,6,8	209	1,5,7,8	239	1,2,3,4,6,7,8
30	2,3,4,5	60	3,4,5,6	90	2,4,5,7	120	4,5,6,7	150	2,3,5,8	180	3,5,6,8	210	2,5,7,8	*240	5,6,7,8

*NOTA: il codice 240 è riservato per il centralino di portineria

Reset programmazione

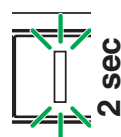
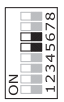
1)	2)						3)		4)	
S1	DIP 1	DIP 2	DIP 3	DIP 4	DIP 5	DIP 6	S2	S1/S2/LED1		
<p>DIP ON</p>	1	1	1	1	1	1		<p>5 sec</p>	<p>2 sec</p>	<p>Prendere nota dell'impostazione di S2, S1 e ripristinarla al termine della programmazione</p>
<p>Configurazioni di fabbrica:</p> <ul style="list-style-type: none"> • Funzioni pulsanti in funzione della combinazione DIP 1-2-3-4 di S2; • Indirizzo intercomunicante assente; • Funzione range e indirizzi min e max assenti; • Reset suonerie; • Ingresso IN 1 ⇒ LED (default). 										

Eseguire le operazioni da 1 a 4											
Programmazione range/suonerie	! 1)		! 2)						3)		4)
	S1	S2	DIP 1	DIP 2	DIP 3	DIP 4	DIP 5	DIP 6	S1/S2/LED1		
Indirizzo minimo range											 <p>Prendere nota dell'impostazione di S2, S1 e riportarla al termine della programmazione</p>
Indirizzo massimo range	impostare codice, TAB. C pag. 13		0	0	0	0	1	0			
Abilitazione range											 
Disabilitazione range											
Selezione suoneria polifonica											 
Selezione suoneria toni (default)			0	1	0	1	1	0			

Eseguire le operazioni da 1 a 4									
		! 2)					3)		4)
! 1)		S1		S2				S1/S2/LED1	
		DIP 1	DIP 2	DIP 3	DIP 4	DIP 5	DIP 6		
Programmazione ingresso IN1 per segnalazione led/allarme/apriporta/attuatore									
Ingresso IN 1 ⇒ LED (default), vedi pag. 124									
Ingresso IN 1 ⇒ ALLARME, vedi pag. 124		0 0		1 1		0			
Ingresso IN 1 ⇒ APRIPORTA, vedi pag. 124									
Ingresso IN 1 ⇒ ATTUATORE INDIRIZZATO, vedi pag. 124				0 0		1 1			
Ingresso IN 1 ⇒ ATTUATORE GENERICO, vedi pag. 124									

! Prndere nota dell'impostazione di S2, S1 e ripristinarla al termine della programmazione

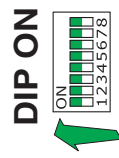
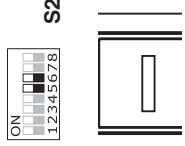
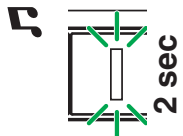

Programmazione diretta chiamata intercomunicante

Consente la programmazione delle chiamate intercomunicanti direttamente dai posti interni.

✓ Necessita di 2 operatori.

Fase 1: ingresso in programmazione

Operatore 1 e Operatore 2 eseguono le seguenti operazioni su 2 posti interni:

1. Impostare dip 1-2-3-4 di S2 in combinazione 1111.
2. Sollevare la cornetta.
3. Premere il tasto 1 e 2 per 3 sec.
 - » Il posto interno emette 1 tono.
 - » Il led verde lampeggia.
 - » Il posto interno entra in fonica.
 - » A questo punto i 2 operatori sono in comunicazione tra di loro.

Fase 2: programmazione chiamata intercomunicante

Operatore 1:

- ▶ Preme il pulsante che vuole programmare per chiamare l'operatore 2 (es. 2).
- » Il posto interno dell'operatore 1 emette un tono di conferma.

Operatore 2:

- ▶ Preme il pulsante che vuole programmare per chiamare l'operatore 1 (es. 1).
- » Il posto interno dell'operatore 2 emette un tono di conferma.

Operatore 1/Operatore 2:

- ▶ Agganciare la cornetta.
- » Il posto interno emette 1 tono.
- » La programmazione dei 2 posti interni è così ultimata.

Per programmare un ulteriore posto interno passare alla FASE 3.



Fase 3: programmazione di altri posti interni

Operatore 1/Operatore 2:

1. Raggiunta la nuova postazione esegue la fase 1 per entrare in comunicazione.
2. Ripetere la fase 2.

N.B. Nel caso in cui si riceve una chiamata durante la programmazione è necessario rispondere alla chiamata e successivamente riprendere la fase di programmazione.

Variatione suonerie monitor

1. Tenere premuto il pulsante  fino a che non verrà emesso un suono di conferma (l'operazione è possibile solo con l'impianto in situazione di riposo; in caso contrario il led di segnalazione lampeggerà per avvisare l'utente).
2. Premere e rilasciare il pulsante  :
 - 1 volta (viene emesso un tono di conferma) per modificare la suoneria di chiamata da posto esterno.
 - 2 volte (vengono emessi 2 toni di conferma) per modificare la suoneria di chiamata da centralino.
 - 3 volte (vengono emessi 3 toni di conferma) per modificare la suoneria di chiamata intercomunicante da posto interno.
 - 4 volte (vengono emessi 4 toni di conferma) per modificare la suoneria della chiamata da piano.
 Ulteriori pressioni del pulsante  ripetono la sequenza appena descritta.
3. Premere e rilasciare il pulsante 1 per scorrere in sequenza le varie suonerie disponibili.
4. Premere il pulsante 2 per confermare la scelta dell'ultima suoneria ascoltata e per uscire (in qualunque momento) dalla modalità di variazione suoneria monitor. All'uscita dalla modalità di variazione suoneria monitor verrà emesso un suono di conferma.

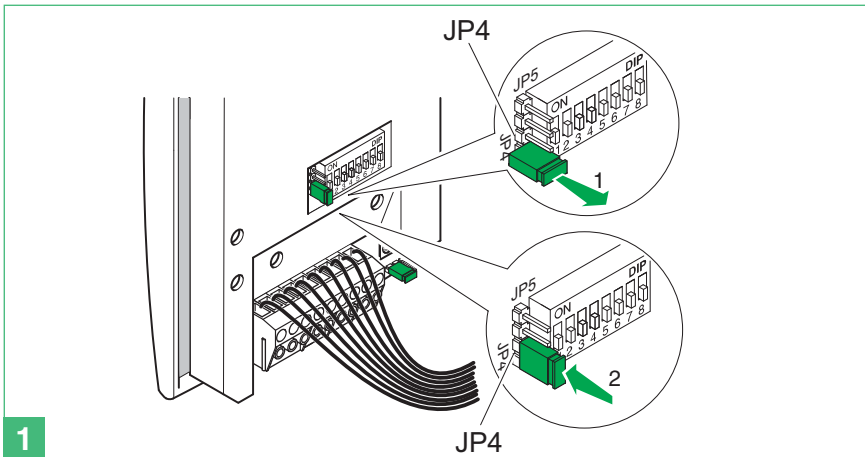

1

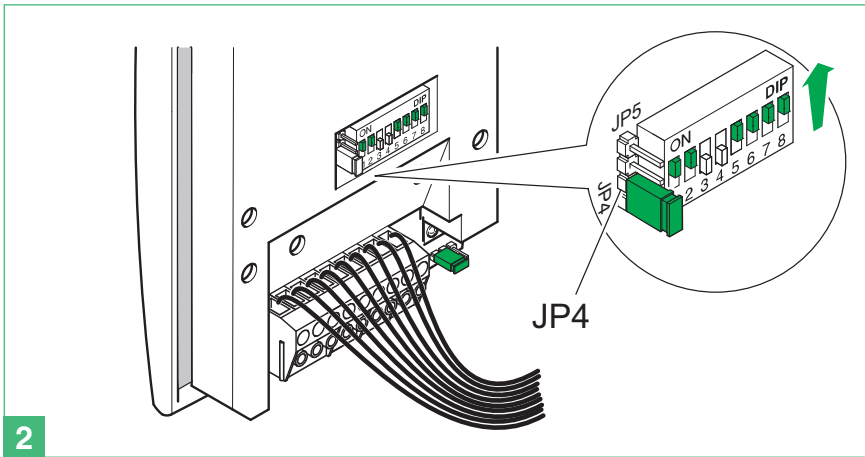

2

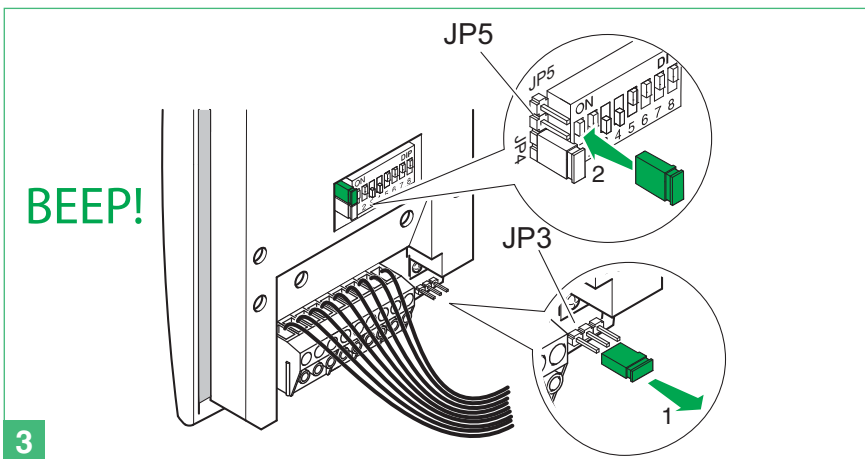

3

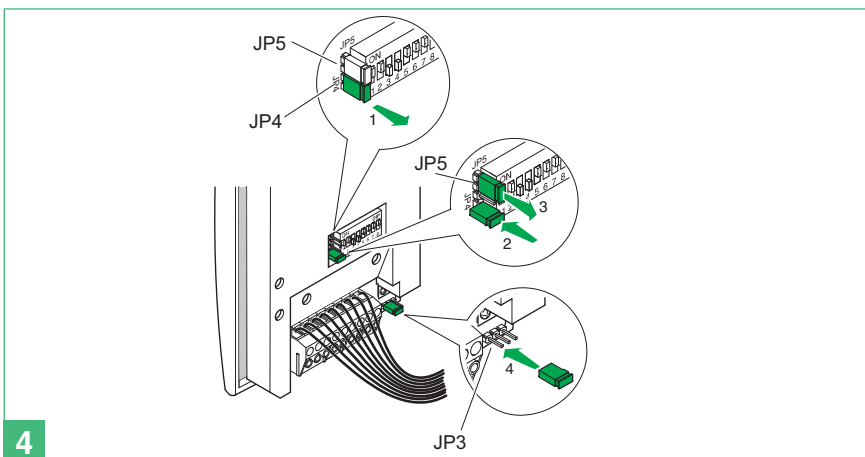

4

Codice	Dip switch ON	
Serratura		
245	1,3,5,6,7,8	Tempo serratura: 2 sec + tono disattivo (default)
246	2,3,5,6,7,8	Tono conferma serratura: attivo
247	1,2,3,5,6,7,8	Tempo serratura: 8 sec
252	3,4,5,6,7,8	Apriporta sempre attivo (default)
253	1,3,4,5,6,7,8	Apriporta attivo solo per utente chiamato

Funzioni impianto		
243	1,2,5,6,7,8	Tempo di attesa reset: 10 sec (default)
244	3,5,6,7,8	Tempo di attesa reset: 1 sec
248	4,5,6,7,8	Invio chiamata: singola (default)
249	1,4,5,6,7,8	Invio chiamata: tripla

254	2,3,4,5,6,7,8	Ripristino default
-----	---------------	---------------------------

Sull'Art. 4882 è possibile effettuare una serie di programmazioni speciali in funzione delle varie esigenze di impianto.

1. Entrare in modalità di programmazione posizionando in verticale il jumper di JP4 (Fig. 1).
2. Impostare sui dip-switch il codice relativo alla funzione che si desidera programmare (Fig. 2), secondo la tabella a pag. 17.
3. Confermare la funzione impostata spostando il jumper da JP3 in posizione JP5 (Fig. 3) e attendere che venga emesso un tono di conferma.
4. Per effettuare un'altra programmazione speciale, rimuovere il jumper da JP5 e ripetere le operazioni descritte al punto 2 e 3.
5. Al termine della procedura riposizionare i jumper nella loro posizione iniziale (Fig. 4): il jumper di JP4 in posizione orizzontale e il secondo jumper da JP5 in posizione JP3.

Warning:

- Install the equipment by carefully following the instructions given by the manufacturer and in compliance with the standards in force.
- All the equipment must only be used for the purpose it was designed for. **Comelit Group S.p.A.** declines any responsibility for improper use of the apparatus, for modifications made by third parties for any reason or purpose, and for the use of accessories and materials which are not originals.
- All the products comply with the requirements of Directive 2006/95/EC (which replaced Directive 73/23/EEC and subsequent amendments), as certified by the **CE** mark they carry.
- Do not route the riser wires in proximity to power supply cables (230/400V).
- Do not insert objects or pour liquids into the device.
- Installation, mounting and assistance procedures for electrical devices must only be performed by specialised electricians.
- Cut off the power supply before carrying out any maintenance work.
- Connect the module-holder frame to earth (see Fig.).
- Do not press and hold the audio hook while the handset is lifted.
- The camera must not be installed opposite bright light sources, or in places where the filmed subject is against the light. To resolve this problem, we recommend modifying the installation height of the camera, which is usually 160 - 165 cm, to a height of 180 cm and pointing the lens downward so as to improve filming quality.
- Cameras with colour CCD sensor have poorer sensitivity in low light conditions than black/white cameras. We therefore recommend, in dimly lit environments, that an additional light source is installed.

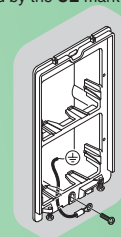

General information	19
External unit	19
Art. 4882	19
Art. 1205/B	19
Installing the external unit	20
Internal units	21
Mounting the Magis internal unit	21
Removing the monitor	21
Art. 6402E	22
Description of monitor	22
Art. 2608	23
Installing door-entry phone Art. 2608	23
General installation and operating instructions	24
Operating distances table	24
Operation	24
Description of button functions and settings	25
Settings for monitor Art. 6402E and Style door-entry phone	25
TAB. A Riser addresses	25
Description of functions	25
Additional main or secondary monitors	26
Default button settings	26
General button programming warnings	26
Programming buttons for generic or coded actuator	27
Programming for intercom call	27
Programming/deleting intercom address (selective intercom only)	27
TAB. B Selective intercom addresses	27
Programming buttons for intercom call	28
Programming buttons for other functions	28
TAB.C Riser addresses	29
Programming reset	29
Programming range/ringtones	30
Programming input IN1 for LED/alarm/lock-release/actuator indication	31
Direct programming of intercom call	32
Monitor ringtone selection	32
Special programming - Art. 4882	33
Wiring diagrams	
MSK/012C Basic diagram for single-family kit Art. 8471MC. Switching on/voltage check with system in standby.....	114
MSK/017AC Diagram for single-family kits Art. 8471MC extended with a second Art. 4882	115
MSK/012/AC Diagram for single-family kit with additional power supply unit Art. 1395	116
MSK/015C Use of remote camera module Art. 1259C	117
SB2/AAR Connection of video amplifier Art. 4833C.....	118
MSK/HCA Addition of a main monitor in parallel. Cascade connection	118
MSK/IC Addition of a main monitor in parallel. Branch connection	119
MSK/A20S Cascade connection of third main monitor with local power supply	119
MSK/A23S Branch connection of 2 main monitors and 2 secondary monitors with the same user code	120
MSK/A21S Cascade connection of 2 main monitors and 1 secondary monitor with the same user code	120
MSK/AAE Connection of additional door-entry phones with branch connection from monitor	121
MSK/AAD Connection of additional door-entry phones with cascade connection from monitor.....	121
MSK/FC Addition of a parallel door-entry phone, with branch connection from riser.....	122
SB/X3 Use for various purposes of button P1 (Art. 2608).....	122
SB2V/AAK Connection of call repetition devices (Art. 1229 or Art. 1122/A)	123
Floor door call connection variant	123

Using IN1 input for LED/ALARM/LOCK-RELEASE/ACTUATOR indication. Activation on closure towards CFP2 124
 Using IN1 input for LED/ALARM/LOCK-RELEASE/ACTUATOR indication. Activation in the presence of voltage in relation to IN2 124
 SB2/AAM2 Use for various purposes of button P1 125
 SMK/EC Connecting actuator relay Art. 1256 125
 GK/AAGC Variant to connect the timed local lock button (request to exit) 126
 SMK/SNP Variant with security door lock and additional power supply 126
 Using the RC network for door lock filter on relay contacts 127

General information

The single-family door entry monitor kits Art. 8471MC can be used in residential or service sector buildings where effective access control and simple installation procedures are required.

In fact, it only requires 2 wires between the external unit and the internal monitor/s to activate the system (calls, audio, video self-ignition), plus 2 wires to power the external unit and the electric lock and 2 wires to power the door entry monitor internal unit.

A wide range of accessories is also available to deal with the needs of any type of system; in fact, in addition to interesting standard type accessories, the system can also be extended by adding door entry monitors and/or door-entry phones and/or external units. This makes it possible to reach a maximum of 2 external units with 4 internal units including door-entry phones and door entry monitors for single-family configuration.

By means of appropriate settings single-family intercom communications (i.e. between users with the same user code) are possible using both door entry monitors and door-entry phones.

Several kits can be connected to a Simplebus main entrance panel and/or a switchboard Art. 1998A.

External unit

Art. 4882

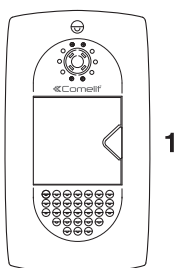

Art. 1205/B

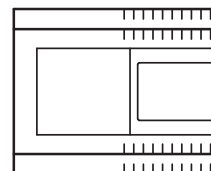

Technical characteristics

Connection to monitor with 2 wires for audio, video, lock-release and call plus 2 wires for power supply from Art. 1205/B.

High sensitivity, adjustable camera with 1/3" CCD sensor.

White LED illumination (6 LED).

Nameplates with LED lighting.

Microphone and loudspeaker volume control.

Flush-mounted box dimensions: 176,5x95,5x35 mm.

The button for Art. 4882 is factory set to call address 1.

External unit dimensions: 176x95x15 mm.

Description of terminal block

LL monitor connection (video, call, audio, lock-release).

RTE request to exit input.

~ ~ external unit power supply.

SE. NC. - SE NO. - SE C. electric lock connection.

Technical characteristics

The transformer provides 2 outputs: one to power the external unit and the electric lock and the other to power the monitor.

Dimensions: 105x85x85 mm (6 DIN modules).

500 mA delayed protection fuse.

Description of terminal block

AC230V network voltage input.

~ ~ AC output for external unit and electric lock.

+ - 20V DC power supply output of the monitor.

Installing the external unit

EN

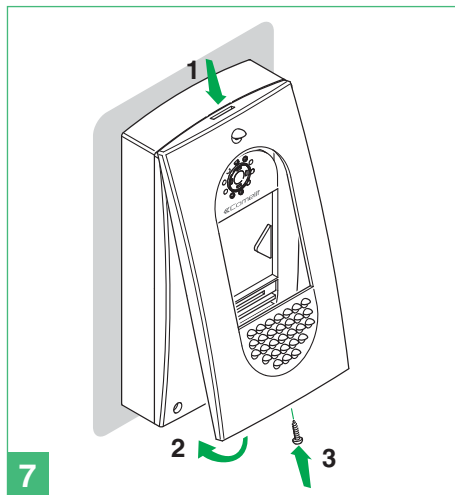
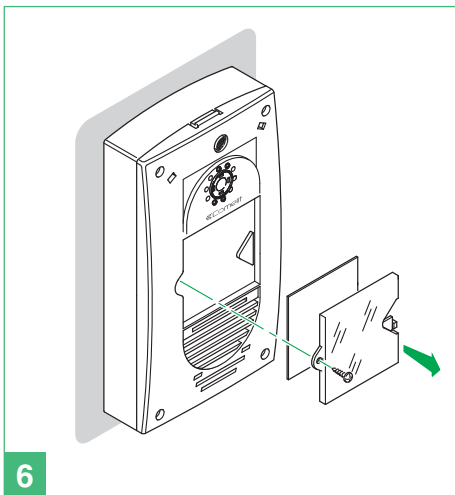
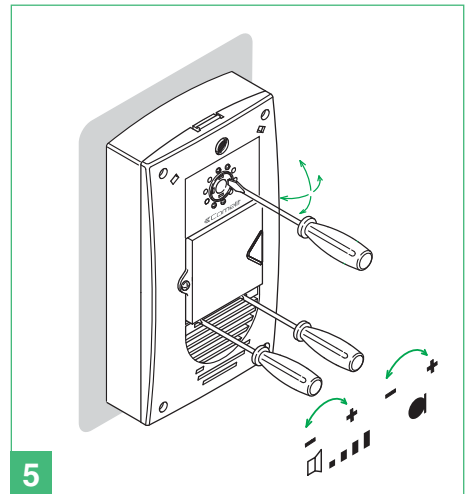
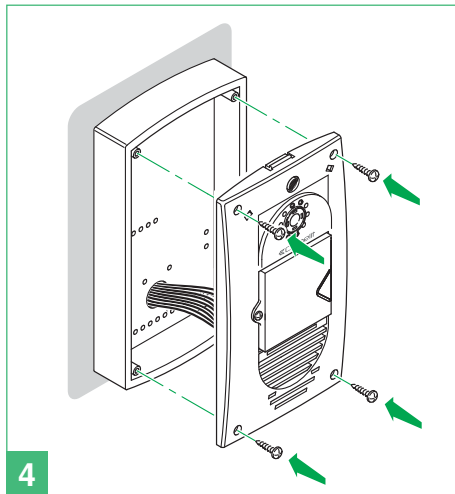
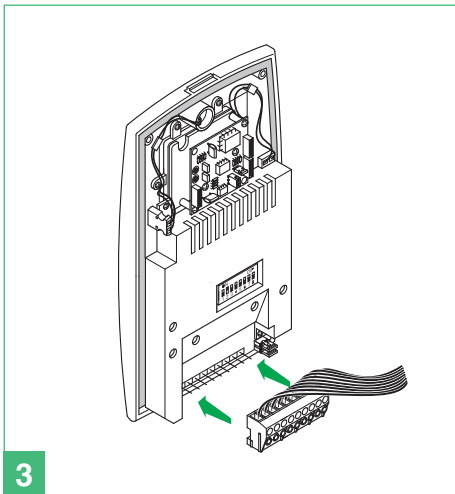
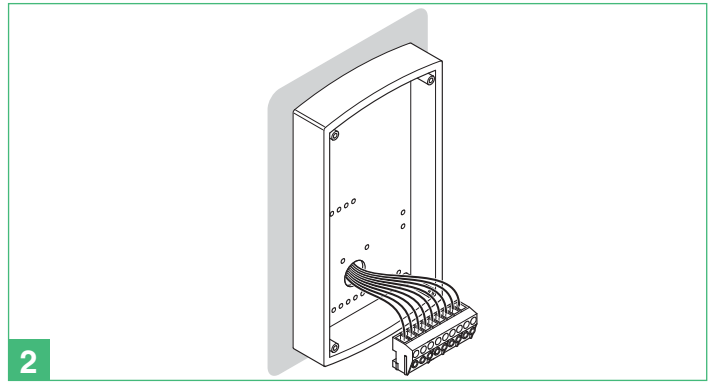
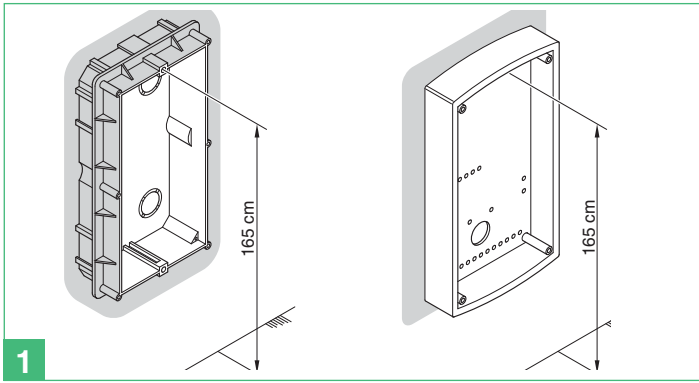
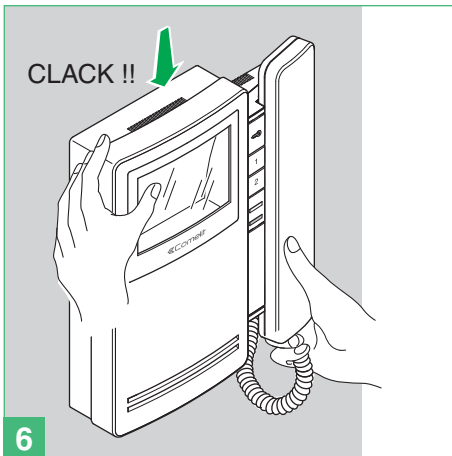
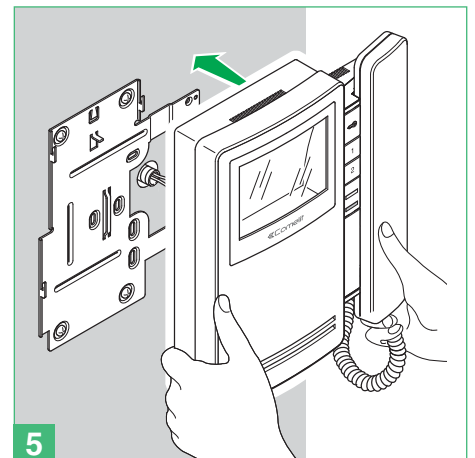
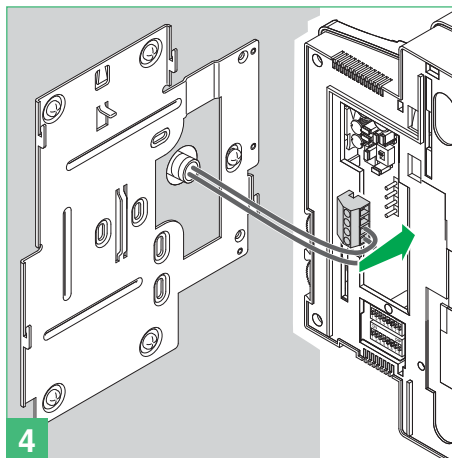
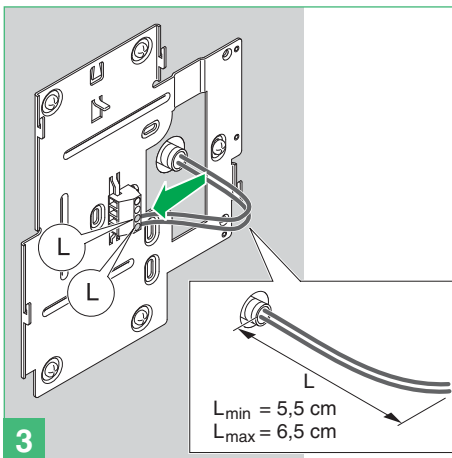
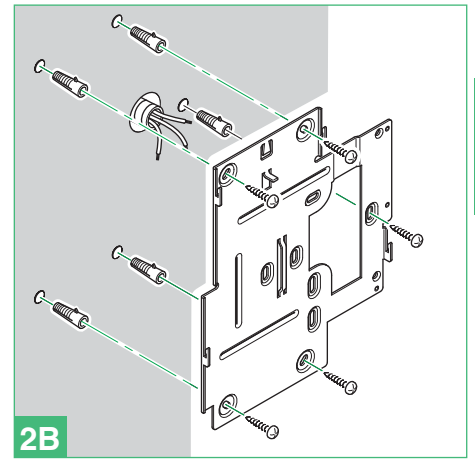
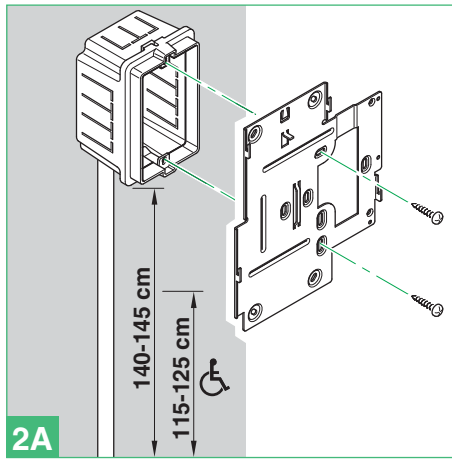
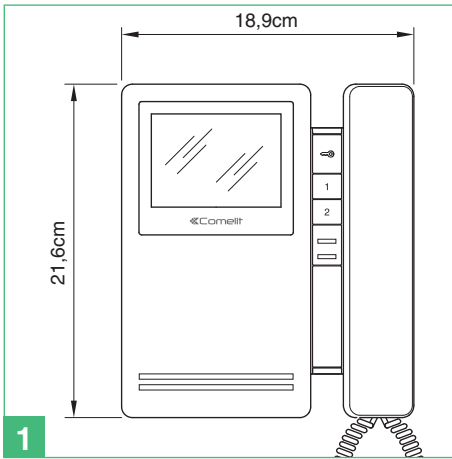

Fig. 4 - NOTE Before fixing the 4 screws, make sure that there is no need to program the special functions described on page 33.

Fig. 5 - NOTE Loosen the four screws slightly to unlock the camera and allow adjustment.

Mounting the Magis internal unit



Removing the monitor

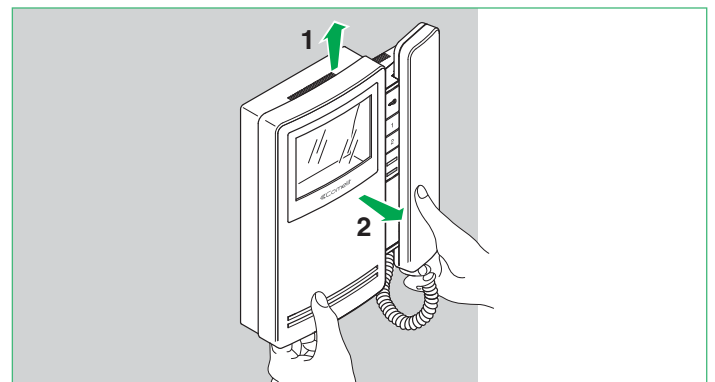

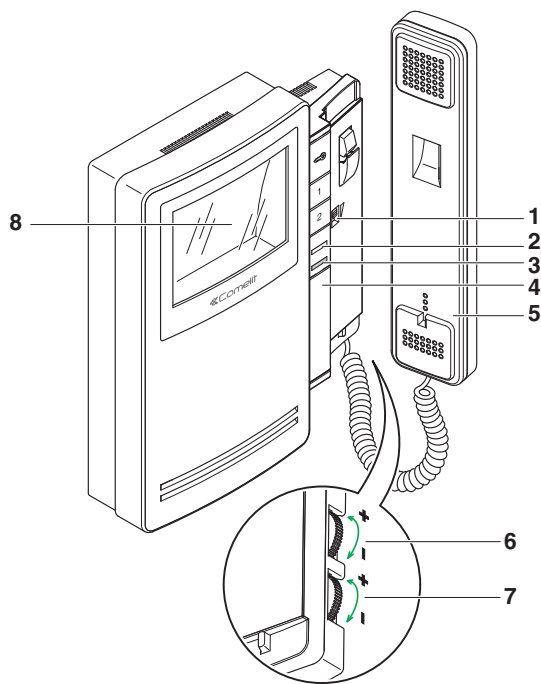

Monitor description:

- 1 Call volume adjustment / Privacy function selector (Privacy service means exclusion of the call from the external unit and from intercommunicating interphones or video doorphones; activation of the Privacy function is shown by a red indicator appearing on the left-hand side of the selector).
- 2 Indicator LED for system busy/Doctor function enabled/door open
- 3 Red indicator - Privacy enabled.
- 4 Space for additional button installation with accessory Art. 6333, Art. 6434.
- 5 Monitor handset (lift handset to start communication).
- 6 Colour intensity adjustment knob.
 - ▶ To increase the value, turn anticlockwise.
- 7 Brightness control knob.
 - ▶ To increase the value, turn anticlockwise.
- 8 3,5" colour screen.

Description of buttons:

- ☞ Door-opening pushbutton.
- 1 Key 1 general actuator (programmable).
- 2 Self-ignition key 2 (programmable).

Description of monitor

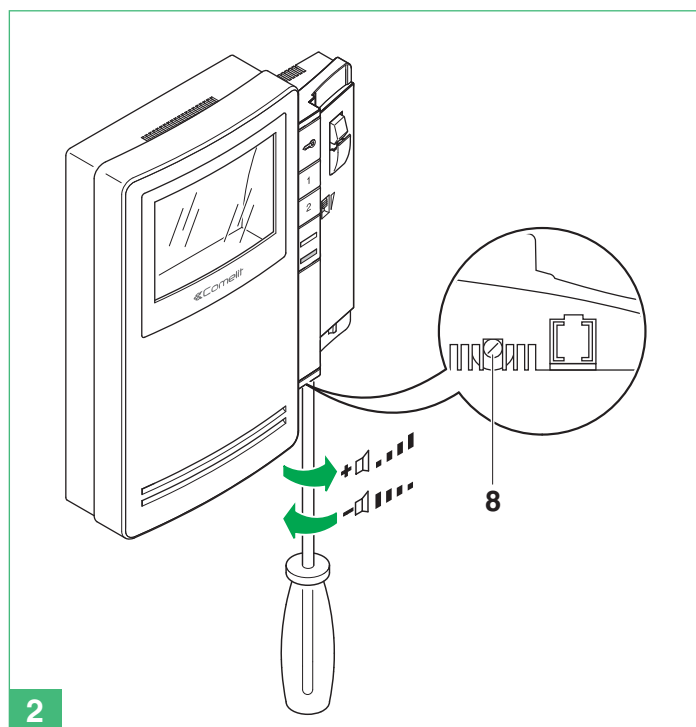
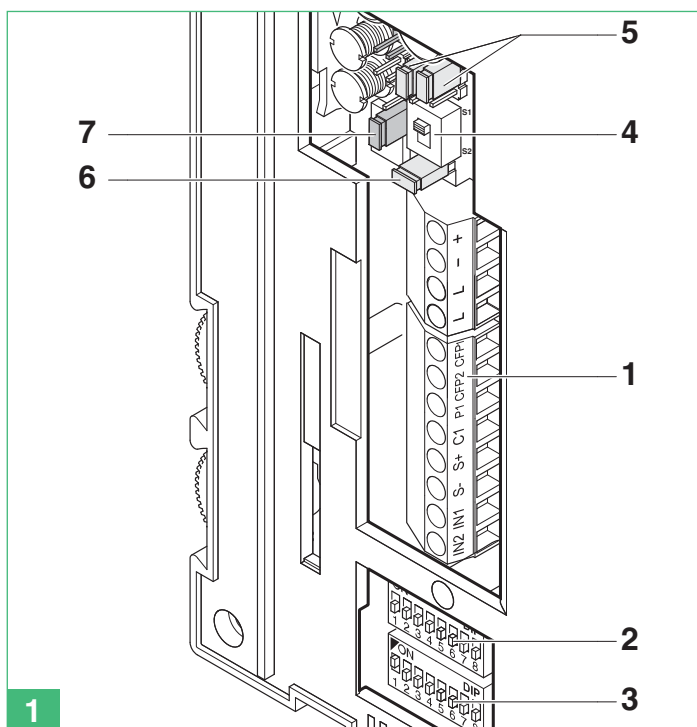

- 1 Terminal block for system connection:
 - + - Power supply terminals.
 - L L Bus line connection terminals.
 - CFP1 CFP2 Floor door call input.
 - P1 C1 Button 1 terminals for various services.
 - To have a C.NO. contact (24 V-100 mA max.), move jumpers CV3 and CV4. to position B.
 - S+ S- Terminals for call repetition device.
 - IN1 IN2 LED input (programmable).
- 2 S1 User code programming microswitches.
- 3 S2 Microswitches for programming buttons and functions (marked with a red corner):
 - DIP 1-2-3-4 for button function programming.
 - DIP 5-6 access to programming.
 - DIP 7 for power supply voltage management (see diagrams and variants on page 114), default = OFF .

- DIP 8:
 - ON secondary bracket.
 - OFF main bracket (default).
- 4 SW3 Selector for Simplebus 1 (S1- default) or Simplebus 2 (S2) modes.
- 5 CV3 CV4 Jumper for freeing button 1 (C.NO. contact 24 V-100 mA max.).
 - A button 1 general actuator (default) or programmable.
 - B button 1 for various uses.
- 6 CV5 Jumper for video closure.
- 7 CV6 selector for using input IN 1 (see page 124).
- 8 Loudspeaker volume adjustment (for setting intercom audio only).

Cannot be used for the intercom function.
The door-entry phone should always be mounted using Art. 1214/2C as illustrated in connection diagram MSK/FC a pag. 122.

- 1 Privacy function indicator.
- 2 3-position ringtone/Privacy service selector:
High position: Maximum ringtone volume.
Middle position: Medium ringtone volume.
Low position: Privacy function activation.
Privacy service means exclusion of the call ringtone from the external unit and switchboard; activation of the Privacy function is signalled by a red indicator appearing at the top right-hand side).
- 3 Trimmer for adjusting the microphone volume.
- 4 User code programming microswitches.
- 5 System connection terminals:
L L Bus line connection.
CFP CFP Floor door call input.
P1 C1 Button P1 terminals for various purposes (contact C. NO 24 V - 100 mA max.) (remove CV1 and CV2, see variant SB/X3 pag. 122).
S+ S- Terminals for call repetition device.
- 6 CV1 CV2 Jumpers to be removed in order to have potential-free C. NO contact on button P1.
- 7A/7B JP1 Jumpers for selecting the switchboard call (position C) / generic actuator (position A) function of button P1.

Description of buttons:

- Key button.
- P1 Button P1 for switchboard call / generic actuator / button for various purposes present on terminal block (P1 C1).

Clean using a damp cloth. Do not use alcohol or other aggressive products.

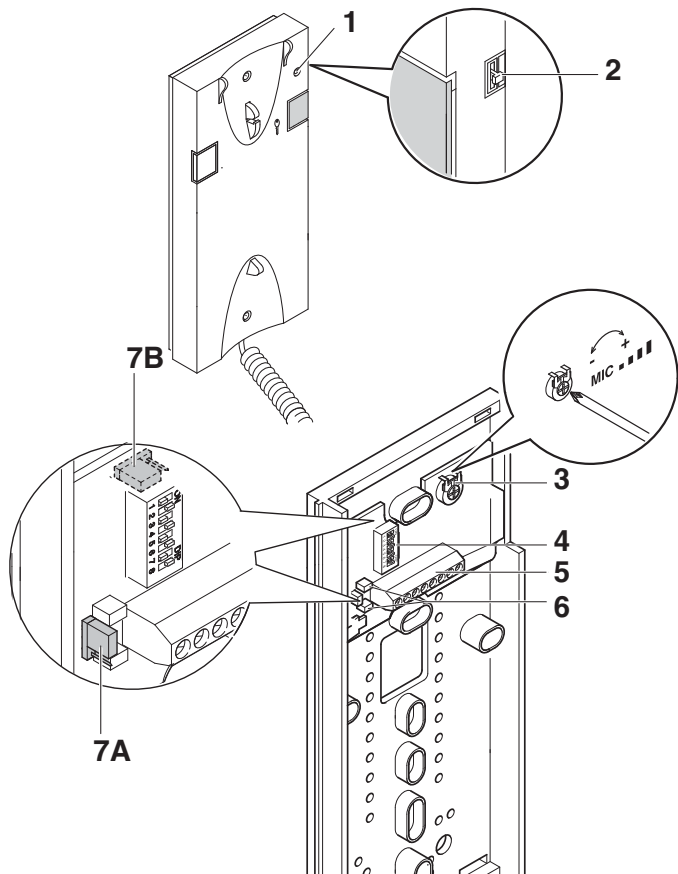

Installing door-entry phone Art. 2608

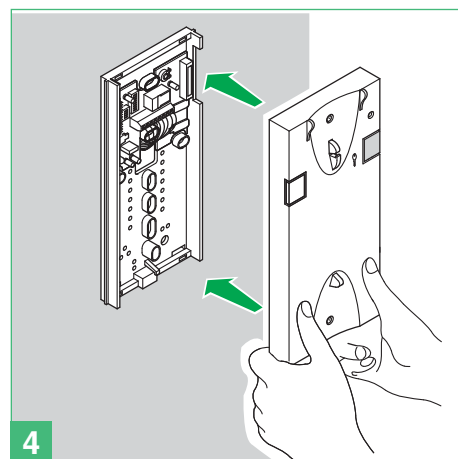
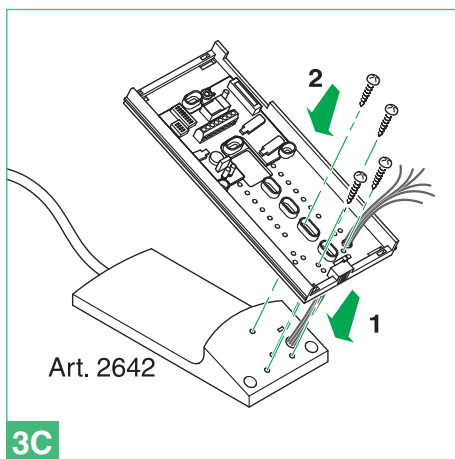
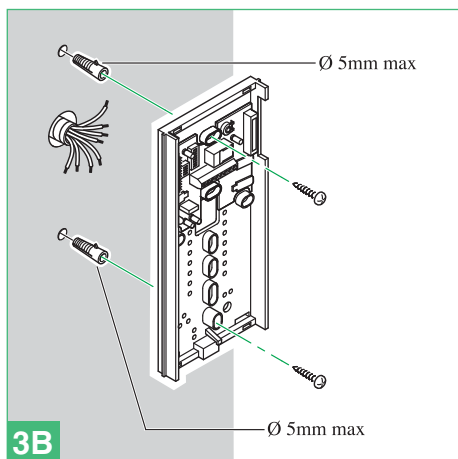
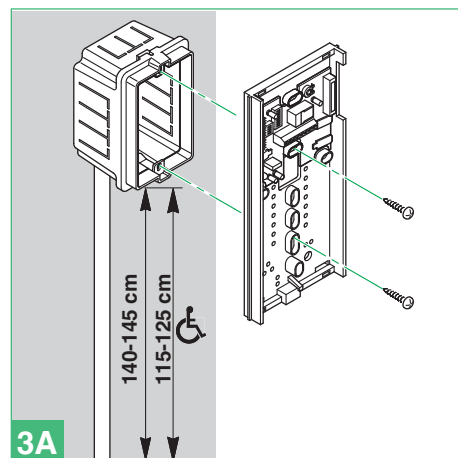
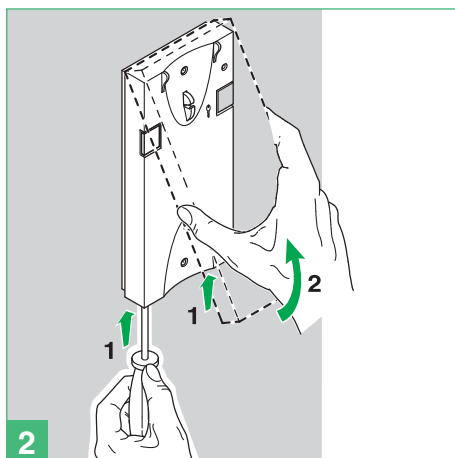
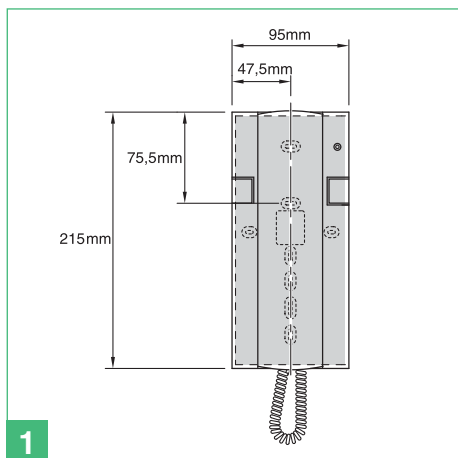

General installation and operating instructions

The maximum total distance between the external unit and the furthest monitor is 400 m (with amplifier Art. 4833C).
 The total number of internal units with the same user code added to the number of call repetition devices connected to these internal units cannot exceed 4.
 Connect only one call repetition device for each internal unit.
 The MAX. cable length between the internal unit and call repetition device is 20 m. A shielded cable should be used for the connection and should not run close to heavy inductive loads or power supply cables (230 V / 400 V).

Operating distances table

		A/G MAX	B/E MAX	C MAX	D MAX	F MAX	Art. 1216
Comelit Art. 4577 1 mm ² (Ø 1,2 mm AWG 17)		50 m (165 feet)	50 m (165 feet)	200 m (655 feet)	100 m (330 feet)	150 m (495 feet)	
Comelit Art. 4576-4578	0,5 mm ² (Ø 0,8 mm AWG 20) bus		25 m (85 feet)	200 m (655 feet)	100 m (330 feet)	150 m (495 feet)	
	1,5 mm ² (Ø 1,4 mm AWG 15) power	75 m (245 feet)	100 m (330 feet)				
UTP5 cat. 5 0,2 mm ² (Ø 0,5 mm AWG 24)				190 m (625 feet)	60 m (195 feet)	150 m (495 feet)	
0,28 mm ² (Ø 0,6 mm AWG 23)		5 m (15 feet)		190 m (625 feet)	60 m (195 feet)	150 m (495 feet)	
0,5 mm ² (Ø 0,8 mm AWG 20)		25 m (85 feet)	25 m (85 feet)	190 m (625 feet)	60 m (195 feet)	150 m (495 feet)	
1 mm ² (Ø 1,2 mm AWG 17)		50 m (165 feet)	50 m (165 feet)	190 m (625 feet)	60 m (195 feet)	150 m (495 feet)	
1 mm ² (Ø 1,2 mm AWG 17)		50 m (165 feet)	50 m (165 feet)	120 m (395 feet)	40 m (130 feet)	100 m (330 feet)	
1,5 mm ² (Ø 1,4 mm AWG 15)		75 m (245 feet)	100 m (330 feet)	190 m (625 feet)	60 m (195 feet)	150 m (495 feet)	
2,5 mm ² (Ø 1,8 mm AWG 13)		100 m (330 feet)	150 m (495 feet)	190 m (625 feet)	60 m (195 feet)	150 m (495 feet)	

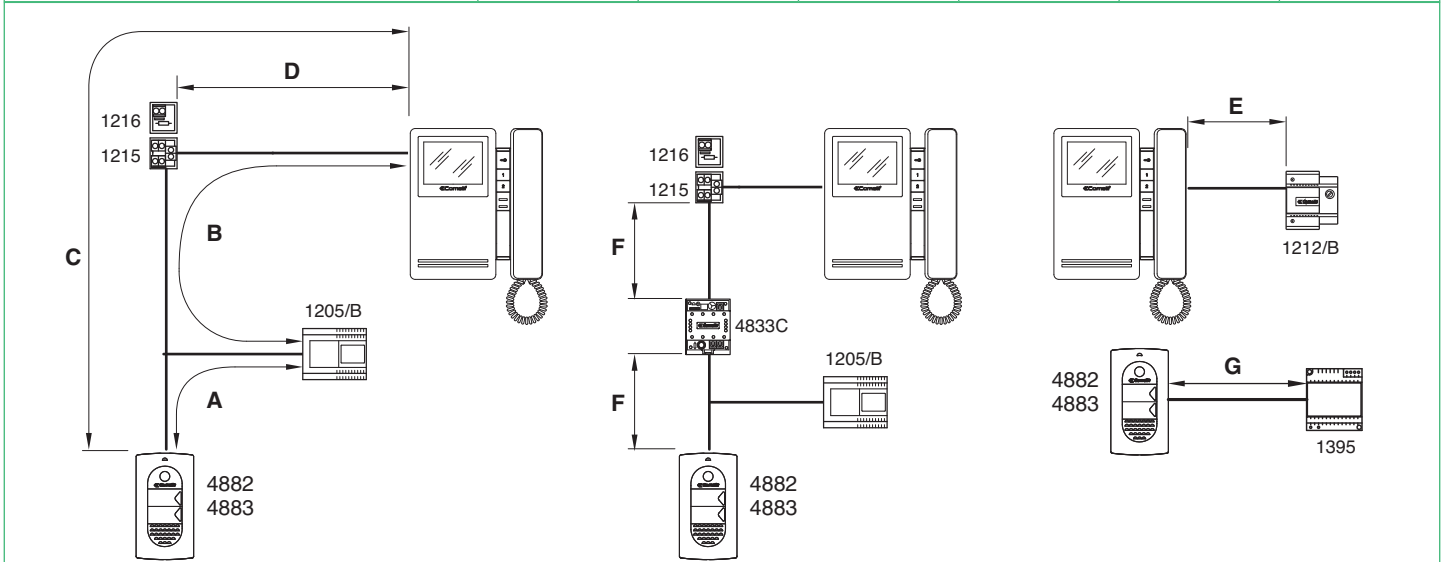

Operation



In case of a persistent short-circuit on the bus line, the external unit emits an intermittent signalling tone.

When the visitor presses the call button, caller illumination and the internal call ringtone (if the Privacy function is not enabled) are activated and image is displayed on the main monitor/s for approx. 60 seconds.

The maximum duration of the conversation between the external and internal units is 90 seconds.

A call confirmation tone sounds at the external unit; in systems with 2 or more entrances, if the external unit gives a busy tone instead of replicating the ringtone, this means that another communication is already in progress with another external unit.

For programming user addresses different from the factory settings (1 and 2), see page 25.

For the intercom functions of the Magis Kit System, see page 27.

Description of button functions and settings

Settings for monitor Art. 6402E and Style door-entry phone

Position of the microswitches for monitor Art. 6402E

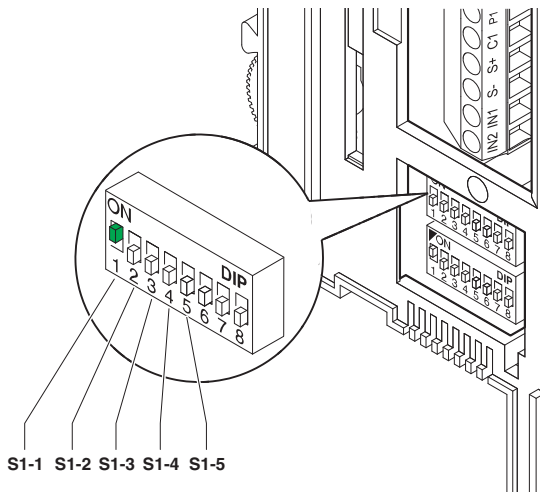

► For door-entry phones Art. 2608, Art. 2610 and Art. 2628, set dip switches **S1-6, S1-7, S1-8** to **OFF**

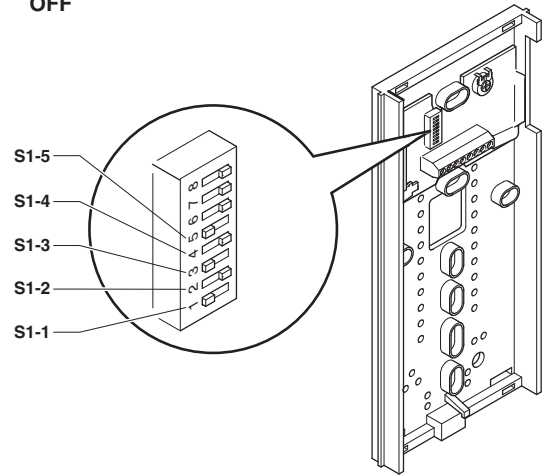

The values of **S1-1, S1-2, S1-3, S1-4** and **S1-5** define the **call address** of the monitor and door-entry phones as shown in the table below.

TAB. A Riser addresses

Code	S1
1	

Description of functions

☞ **Door opener:** Pressing the Door opener Pushbutton triggers the lock connected to the external unit.

Actuator: Pressing Pushbutton 1 set to Actuator mode allows activation of Art. 1256, which can be used, for example, to open gates, swinging doors or to activate the cyclic camera module Art. 1259/C.

Free Pushbutton: The indication Free Pushbutton means that it is possible to use Pushbutton 1 as a C.NO. contact in the terminal board using suitable settings, as illustrated in variant SB2/AAM2 pag. 125.

Self-ignition / Video request

- ✓ Self-ignition can be disabled.
- ✓ Self-ignition is possible only when the system is in standby.
- ✓ Self-ignition is recommended only for systems with 1 or 2 entrances.

Press button 2 in this mode to display the image transmitted by the external unit on the monitor, even if no call has been made.

In systems with 2 external units, it is possible to view the image from one external unit or the other alternately ("toggle" function) by pressing button 2. On secondary monitors (**S2** DIP8 ON), button 2 also has the video request function and can be used to switch on a monitor on receipt of a call from the external unit.

Enabling:

- press the monitor self-ignition button and hold for longer than 4 seconds.
- » confirmation ringtone.

Disabling:

- press the self-ignition button and hold for longer than 4 seconds.
- » 4 confirmation tones.

Ignition:

- press and immediately release the specific button (button 2 - if the factory settings have been retained).

Switchboard call

Press the button set in this mode to transmit a call to the porter switchboard.

Single-family intercom call

This function can be used to transmit a call to the other units (door entry monitors and/or door-entry phones) set to the same call address.

- By lifting the handset, the receiver of the call starts communicating with the caller. Communication is ended by hanging up the handset. An intercom call does not have priority over a conversation/call with the external unit. In this case, during an intercom call attempt, the LED indicator will flash for a few seconds to signal that the system is busy.

Call from the external unit

In any case, a call from the external unit always takes priority over intercom communication. In this case, users who are already speaking will hear a tone similar to the ringtone in the handset if the call is for them, otherwise a triple signal tone will sound.

- To answer the call from the external unit, simply lift the handset of any free unit or hang up and lift the handset of a unit engaged in the intercom call.

Doctor

This function enables automatic activation of the lock-release when a call is made from an external unit to the address of the internal unit for which the function was enabled.

Enabling/Disabling:

- press the button set for this function and hold for 2 seconds.
- » when the function is enabled, the LED indicator stays on.

Additional main or secondary monitors

EN

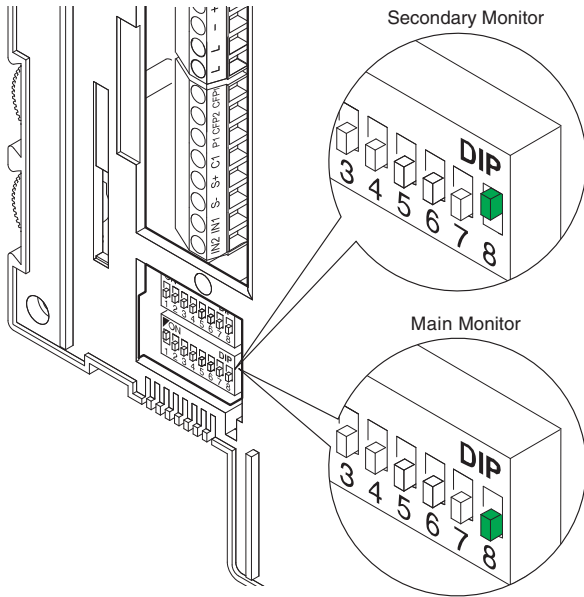

The setting of S2 DIP 8 defines whether the bracket in question will be managed as main (M) or secondary (S). The external unit can manage up to a maximum of 4 door entry monitors or door-entry phones for each call button. In the classic Magis Kit configuration, it is therefore possible to have at most 2 secondary door entry monitors and 2 main door entry monitors for each call button, all powered by the same **Art. 1205/B**. It is possible to manage up to 3 main door entry monitors within the same family unit (i.e. set to the same user code). In this particular configuration, the additional main door entry monitors must each be powered by the special **Art. 1212/B** (see variant MSK/HCA and MSK/IC, page 118, 119). When a call is made from the external unit, the monitor switched on will be the main door entry monitor. Any other secondary monitors in the same family unit will remain off. When responding to a call from the external unit using a secondary door entry monitor, the image is automatically displayed on the monitor. At this point, the main door entry monitor switches off and the image appears on the door entry monitor on which the 2 Self-ignition / Video request button was pressed. To display the image without activating audio communication with the external unit, press the 2 button - Self-ignition / Video request.

Default button settings

DIP S2								with Art. 6433, 6434			
DIP 1	DIP 2	DIP 3	DIP 4	P1	P2			P3	P4	P5	P6
0	0	0	0	CCS	AI	🔑	📞	ACT	D	PAN	K
1	0	0	0	ACT	AI			INT	INTb	D	CCS
0	1	0	0	INT	AI	🔑	📞	INTb	ACT	CCS	CCP
1	1	0	0	ACT	CCS			ACT	PAN	K	D
0	0	1	0	ACT	ACT	🔑	📞	ACT	ACT	ACT	ACT
1	0	1	0	INT	ACT			CCS	CCP	INTb	PAN
0	1	1	0	AI	D	🔑	📞	K	CCS	CCP	INTb
1	1	1	0	INTb	INT			AI	INT	PAN	D
0	0	0	1	CCS	PAN	🔑	📞	D	AI	INT	INTb
1	0	0	1	K	CCS			PAN	CCP	AI	INT
0	1	0	1	CCP	K	🔑	📞	PAN	ACT	INT	AI
1	1	0	1	PAN	CCP			CCS	K	ACT	D
0	0	1	1	D	INTb	🔑	📞	INT	ACT	AI	CCS
1	0	1	1	INT	INT			INT	INT	INT	INT
0	1	1	1	NULL	NULL	NULL	NULL	NULL	NULL	NULL	NULL
1	1	1	1	PROG							

Legend

🔑	Lock- release	CCS	Switchboard call	INTb	Two-family intercom - for KIT only
📞	Speech	K	Guardian door-entry phone call	NULL	No function
ACT	Actuator	D	Doctor	PROG	Programmed functions, see pages 26-27-28-29. In this Dip switch setting, the buttons control the programmed functions; the NON-programmed buttons control functions referred to on line 0000
AI	Self-ignition	PAN	Panic		
CCP	Main switchboard call	INT	Programmable intercom, general or selective - standard single-family calling for KIT and Simplebus Top		



General button programming warnings

If the default settings (see table on page 26) do not reflect requirements, the buttons can be programmed differently by carrying out the steps below. At the end, set S2 DIP switches 1-2-3-4 to the combination 1111 (PROG setting in the configuration tables on pages 26,27,28,29).

In this dip switch setting, the buttons control the programmed functions; the NON-programmed buttons control functions referred to on line 0000 (see table on page 26). Restore the user code setting on S1, see table A on page 25.

Programming buttons for intercom call

DIP S2				with Art. 6433, 6434				DIP S1					
DIP 1	DIP 2	DIP 3	DIP 4	P1	P2			P3	P4	P5	P6	ADDRESS 1 2 3 4 5 6 7 8	
0	0	0	0										
1	0	0	0					INT	INTb				
0	1	0	0	INT				INTb					
1	1	0	0										
0	0	1	0										
1	0	1	0	INT						INTb			
0	1	1	0	INTb	INT				INT		INTb		
0	0	0	1							INT	INTb		
1	0	0	1								INT		
0	1	0	1							INT			
1	1	0	1										
0	0	1	1		INTb			INT					
1	0	1	1	INT	INT			INT	INT	INT	INT		
0	1	1	1										
1	1	1	1										
PROG													

Example 1 - Selective intercom

on a monitor with user code 1 and intercom address 1, P3 programming = selective intercom with address 2, P4 = selective intercom with address 3.

Example 2 - KIT intercom

(intercom between 2 contiguous addresses in the range from 1 to 30, with the first being an odd number):

on a monitor with user code 1, P3 programming = general internal call, P4 = two-family intercom with address 2.

1. Set S2 DIP switch 5-6 to the combination 01.
» the LED (green) flashes.
2. Refer to the table on page 28 and select a combination in which the intercom function (INT or INTb) is listed for the buttons you wish to program.

E.g. 1: for P3= single-family intercom, set S2 DIP switches 1-2-3-4 to the combination 1000 or 0011 or 1011 (P3=INT), set S1 with address 2 in accordance with **table B** on page 27, go to point 3.

E.g. 1: for P4= selective intercom, set S2 DIP switches 1-2-3-4 to the combination 1110 or 1011 (P4=INT), set S1 with address 3 in accordance with **table B** on page 27, go to point 3.

E.g. 2: for P3= general internal call and P4= two-family intercom, set S2 DIP switches 1-2-3-4 to the combination 1000 (P3=INT, P4=INTb), set S1 with user code 1 in accordance with **table A** on page 25, go to point 3

3. Press and release the button to be associated with the function
» the LED (green) lights up
» confirmation tone in handset
4. To exit programming mode, set S2 DIP switches 5-6 to the combination 00
» the LED (green) switches off
5. When programming is complete, set S2 DIP switches 1-2-3-4 to the combination 1111. Restore the user code setting on S1, see **table A** on page 25.

Programming buttons for other functions

DIP S2				with Art. 6433, 6434				DIP S1					
DIP 1	DIP 2	DIP 3	DIP 4	P1	P2			P3	P4	P5	P6	ADDRESS 1 2 3 4 5 6 7 8	
0	0	0	0	CCS	AI				D	PAN	K		
1	0	0	0		AI					D	CCS		
0	1	0	0		AI					CCS	CCP		
1	1	0	0		CCS			CCP	PAN	K	D		
0	0	1	0										
1	0	1	0					CCS	CCP		PAN		
0	1	1	0	AI	D			K	CCS	CCP	PAN		
1	1	1	0					AI		PAN	D		
0	0	0	1	CCS	PAN			D	AI				
1	0	0	1	K	CCS			PAN	CCP	AI			
0	1	0	1	CCP	K			PAN			AI		
1	1	0	1	PAN	CCP			CCS	K		D		
0	0	1	1	D						AI	CCS		
1	0	1	1										
0	1	1	1	NULL	NULL	NULL	NULL	NULL	NULL	NULL	NULL		NULL
PROG													

Legend

	Lock- release	CCS	Switchboard call	NULL	No function
	Speech	K	Guardian door-entry phone call	PROG	Programmed functions
AI	Self-ignition	D	Doctor		
CCP	Main switchboard call	PAN	Panic		

Example:

on a monitor with user code 5, P5 programming = self-ignition, P6 = switchboard call.

1. Set S2 DIP switch 5-6 to the combination 01.
» the LED (green) flashes.
2. Refer to the table on page 28 and select a combination in which the desired/necessary functions are listed for the buttons you wish to program.

E.g.: for P5= self-ignition, P6= switchboard call, set S2 DIP switches 1-2-3-4 to the combination 0011 (P5=AI, P6=CCS).

3. Press and release the button to be associated with the function.
» the LED (green) lights up.
» confirmation tone in handset.
4. To exit programming mode, set S2 DIP switches 5-6 to the combination 00.
» the LED (green) switches off.
5. When programming is complete, set S2 DIP switches 1-2-3-4 to the combination 1111.









TAB.C Riser addresses

Code	Dip switch ON	Code	Dip switch ON	Code	Dip switch ON	Code	Dip switch ON	Code	Dip switch ON	Code	Dip switch ON	Code	Dip switch ON	Code	Dip switch ON
1	1	31	1,2,3,4,5	61	1,3,4,5,6	91	1,2,4,5,7	121	1,4,5,6,7	151	1,2,3,5,8	181	1,3,5,6,8	211	1,2,5,7,8
2	2	32	6	62	2,3,4,5,6	92	3,4,5,7	122	2,4,5,6,7	152	4,5,8	182	2,3,5,6,8	212	3,5,7,8
3	1,2	33	1,6	63	1,2,3,4,5,6	93	1,3,4,5,7	123	1,2,4,5,6,7	153	1,4,5,8	183	1,2,3,5,6,8	213	1,3,5,7,8
4	3	34	2,6	64	7	94	2,3,4,5,7	124	3,4,5,6,7	154	2,4,5,8	184	4,5,6,8	214	2,3,5,7,8
5	1,3	35	1,2,6	65	1,7	95	1,2,3,4,5,7	125	1,3,4,5,6,7	155	1,2,4,5,8	185	1,4,5,6,8	215	1,2,3,5,7,8
6	2,3	36	3,6	66	2,7	96	6,7	126	2,3,4,5,6,7	156	3,4,5,8	186	2,4,5,6,8	216	4,5,7,8
7	1,2,3	37	1,3,6	67	1,2,7	97	1,6,7	127	1,2,3,4,5,6,7	157	1,3,4,5,8	187	1,2,4,5,6,8	217	1,4,5,7,8
8	4	38	2,3,6	68	3,7	98	2,6,7	128	8	158	2,3,4,5,8	188	3,4,5,6,8	218	2,4,5,7,8
9	1,4	39	1,2,3,6	69	1,3,7	99	1,2,6,7	129	1,8	159	1,2,3,4,5,8	189	1,3,4,5,6,8	219	1,2,4,5,7,8
10	2,4	40	4,6	70	2,3,7	100	3,6,7	130	2,8	160	6,8	190	2,3,4,5,6,8	220	3,4,5,7,8
11	1,2,4	41	1,4,6	71	1,2,3,7	101	1,3,6,7	131	1,2,8	161	1,6,8	191	1,2,3,4,5,6,8	221	1,3,4,5,7,8
12	3,4	42	2,4,6	72	4,7	102	2,3,6,7	132	3,8	162	2,6,8	192	7,8	222	2,3,4,5,7,8
13	1,3,4	43	1,2,4,6	73	1,4,7	103	1,2,3,6,7	133	1,3,8	163	1,2,6,8	193	1,7,8	223	1,2,3,4,5,7,8
14	2,3,4	44	3,4,6	74	2,4,7	104	4,6,7	134	2,3,8	164	3,6,8	194	2,7,8	224	6,7,8
15	1,2,3,4	45	1,3,4,6	75	1,2,4,7	105	1,4,6,7	135	1,2,3,8	165	1,3,6,8	195	1,2,7,8	225	1,6,7,8
16	5	46	2,3,4,6	76	3,4,7	106	2,4,6,7	136	4,8	166	2,3,6,8	196	3,7,8	226	2,6,7,8
17	1,5	47	1,2,3,4,6	77	1,3,4,7	107	1,2,4,6,7	137	1,4,8	167	1,2,3,6,8	197	1,3,7,8	227	1,2,6,7,8
18	2,5	48	5,6	78	2,3,4,7	108	3,4,6,7	138	2,4,8	168	4,6,8	198	2,3,7,8	228	3,6,7,8
19	1,2,5	49	1,5,6	79	1,2,3,4,7	109	1,3,4,6,7	139	1,2,4,8	169	1,4,6,8	199	1,2,3,7,8	229	1,3,6,7,8
20	3,5	50	2,5,6	80	5,7	110	2,3,4,6,7	140	3,4,8	170	2,4,6,8	200	4,7,8	230	2,3,6,7,8
21	1,3,5	51	1,2,5,6	81	1,5,7	111	1,2,3,4,6,7	141	1,3,4,8	171	1,2,4,6,8	201	1,4,7,8	231	1,2,3,6,7,8
22	2,3,5	52	3,5,6	82	2,5,7	112	5,6,7	142	2,3,4,8	172	3,4,6,8	202	2,4,7,8	232	4,6,7,8
23	1,2,3,5	53	1,3,5,6	83	1,2,5,7	113	1,5,6,7	143	1,2,3,4,8	173	1,3,4,6,8	203	1,2,4,7,8	233	1,4,6,7,8
24	4,5	54	2,3,5,6	84	3,5,7	114	2,5,6,7	144	5,8	174	2,3,4,6,8	204	3,4,7,8	234	2,4,6,7,8
25	1,4,5	55	1,2,3,5,6	85	1,3,5,7	115	1,2,5,6,7	145	1,5,8	175	1,2,3,4,6,8	205	1,3,4,7,8	235	1,2,4,6,7,8
26	2,4,5	56	4,5,6	86	2,3,5,7	116	3,5,6,7	146	2,5,8	176	5,6,8	206	2,3,4,7,8	236	3,4,6,7,8
27	1,2,4,5	57	1,4,5,6	87	1,2,3,5,7	117	1,3,5,6,7	147	1,2,5,8	177	1,5,6,8	207	1,2,3,4,7,8	237	1,3,4,6,7,8
28	3,4,5	58	2,4,5,6	88	4,5,7	118	2,3,5,6,7	148	3,5,8	178	2,5,6,8	208	5,7,8	238	2,3,4,6,7,8
29	1,3,4,5	59	1,2,4,5,6	89	1,4,5,7	119	1,2,3,5,6,7	149	1,3,5,8	179	1,2,5,6,8	209	1,5,7,8	239	1,2,3,4,6,7,8
30	2,3,4,5	60	3,4,5,6	90	2,4,5,7	120	4,5,6,7	150	2,3,5,8	180	3,5,6,8	210	2,5,7,8	*240	5,6,7,8

*NOTE: code 240 is reserved for the porter switchboard

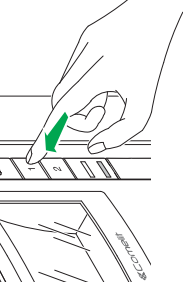
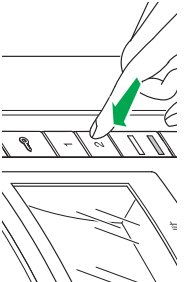
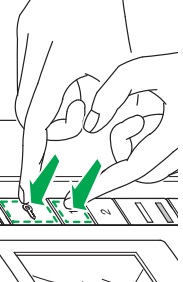
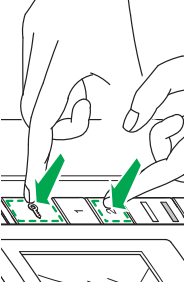
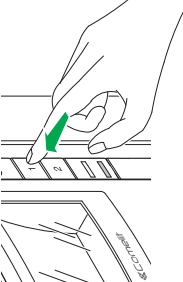
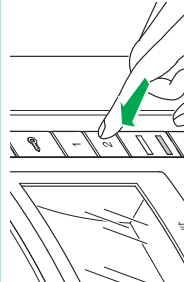
Programming reset

! 1)	! 2)						3)	4)	
S1	DIP 1	DIP 2	DIP 3	DIP 4	DIP 5	DIP 6	S2	S1/S2/LED1	
<p>DIP ON</p>	1	1	1	1	1	1	<p>5 sec</p>	<p>2 sec</p>	<p>Take note of the S2, S1 setting and restore it when programming is complete.</p>
<p>Factory settings:</p> <ul style="list-style-type: none"> • Button functions for the S2 DIP switch 1-2-3-4 combination; • Intercom address absent; • Range function and min./max. addresses absent; • Ringtone reset; • IN 1 input ⇒ LED (default). 									

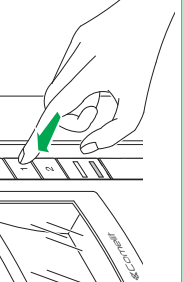
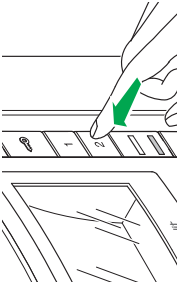
Programming range/ringtones		Carry out steps 1 to 4							S1/S2/LED1	4)	
		1)	2)								3)
		S1	DIP 1	DIP 2	DIP 3	DIP 4	DIP 5	DIP 6	S2		
Range minimum address											 <p>Take note of the S2, S1 setting and restore it when programming is complete.</p>
Range maximum address		set code, TAB. C on page 29	0	0	0	0	1	0	  	     	
Enable range											
Disable range											
Select polyphonic ringtone			0	1	0	1	1	0	  	 	
Select tone sound (default)											

Carry out steps 1 to 4											
Programming input IN1 for LED/alarm/lock-release/ actuator indication	1)		2)						3)		4)
	S1	S2	DIP 1	DIP 2	DIP 3	DIP 4	DIP 5	DIP 6	S1/S2/LED1		
IN 1 input ⇒ LED (default), see page 124											
Input IN 1 ⇒ ALARM, see page 124			0	0	0	1	1	0			
Input IN 1 ⇒ LOCK-RELEASE, see page 124											
Input IN 1 ⇒ CODED ACTUATOR, see page 124	set code, TAB. C on page 29		0	0	1	0	1	0			
Input IN 1 ⇒ GENERIC ACTUATOR, see page 124	DIP ON 										

Direct programming of intercom call

Allows direct programming of intercom call via the internal units.
 ✓ Requires 2 operators.

Step 1: enter programming mode

Operator 1 and Operator 2 carry out the following procedures on 2 internal units:

1. Set S2 DIP switches 1-2 -3-4 to the combination 1111.
2. Lift the handset.
3. Press and hold buttons 1 and 2 for 3 sec.
 - » *The internal unit emits 1 tone.*
 - » *The green LED flashes.*
 - » *The internal unit enters audio mode.*
 - » *At this point the 2 operators will be communicating with each other.*

Step 2: intercom call programming

Operator 1:

- ▶ Press the button you want to program to call operator 2 (e.g. 2).
- » *The internal unit manned by operator 1 emits a confirmation tone.*

Operator 2:

- ▶ Press the button you want to program to call operator 1 (e.g. 1).
- » *The internal unit manned by operator 2 emits a confirmation tone.*

Operator 1/Operator 2:

- ▶ Hang up the handset.
- » *The internal unit emits 1 tone.*
- » *Programming of the 2 internal units is now complete.*

To program another internal unit, move on to STEP 3.



Step 3: programming other internal units

Operator 1/Operator 2:

1. Once the new station has been reached, carry out step 1 to begin communication.
2. Repeat step 2.

NOTE If a call is received during programming, it must be answered and the programming procedure resumed afterwards.

Monitor ringtone selection

1. Press and hold button  until a confirmation tone is emitted (this procedure is only possible with the system in standby; otherwise the LED indicator will flash to warn the user).
2. Press and release button  :
 - once (1 confirmation tone is emitted) to change the ringtone for calls from the external unit.
 - twice (2 confirmation tones are emitted) to change the ringtone for calls from the switchboard.
 - 3 times (3 confirmation tones are emitted) to change the ringtone for intercom calls made from the internal unit.
 - 4 times: (4 confirmation tones are emitted) to change the floor door call ringtone.
 Any further pressing of button  repeats the sequence described above.
3. Press and release button 1 to scroll through the various available ringtones in sequence.
4. Press button 2 to confirm selection of the last ringtone heard and to exit (at any time) the monitor ringtone change mode. On exiting the monitor ringtone selection mode a confirmation tone will be emitted.

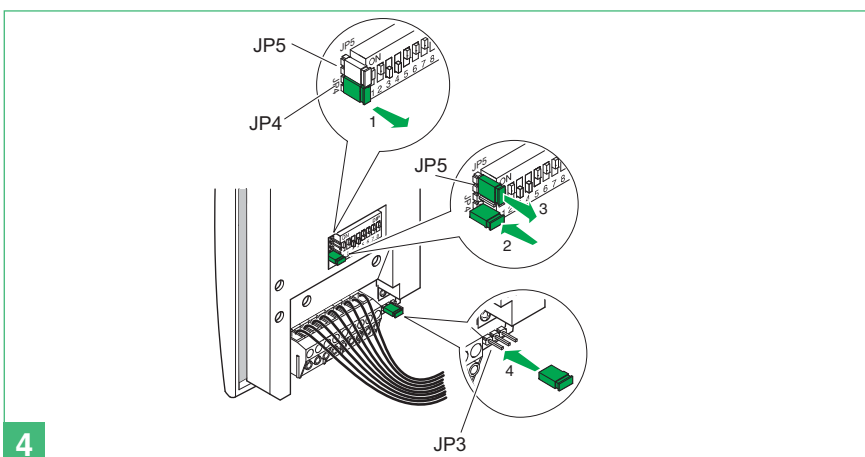
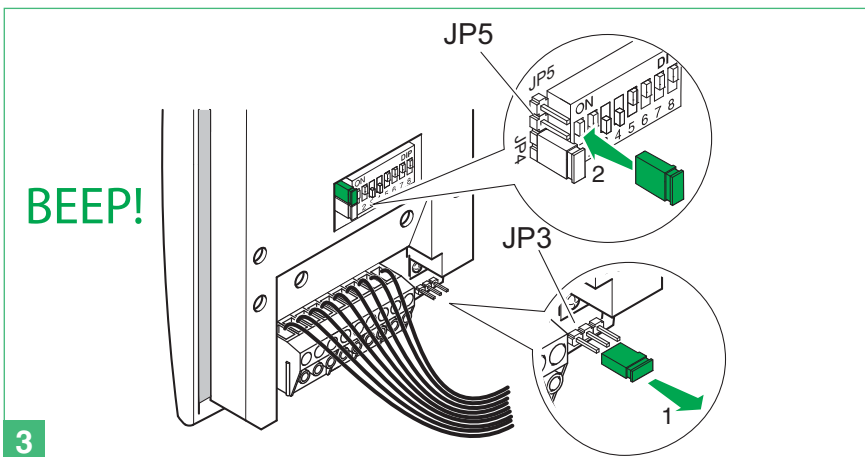
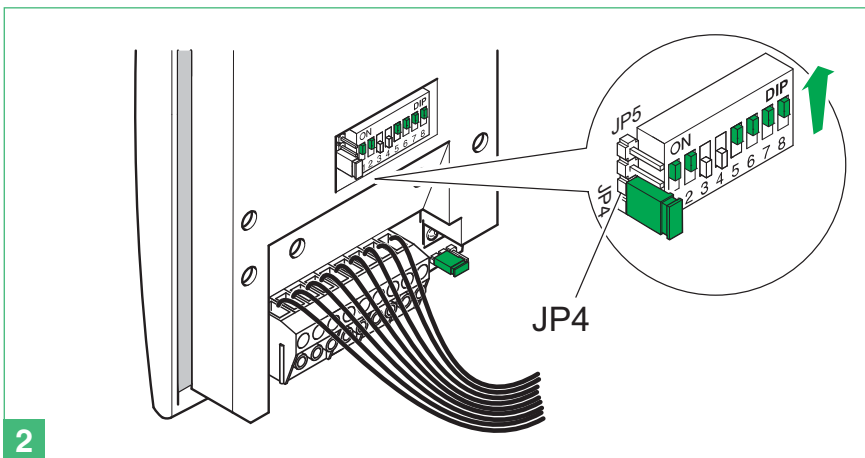
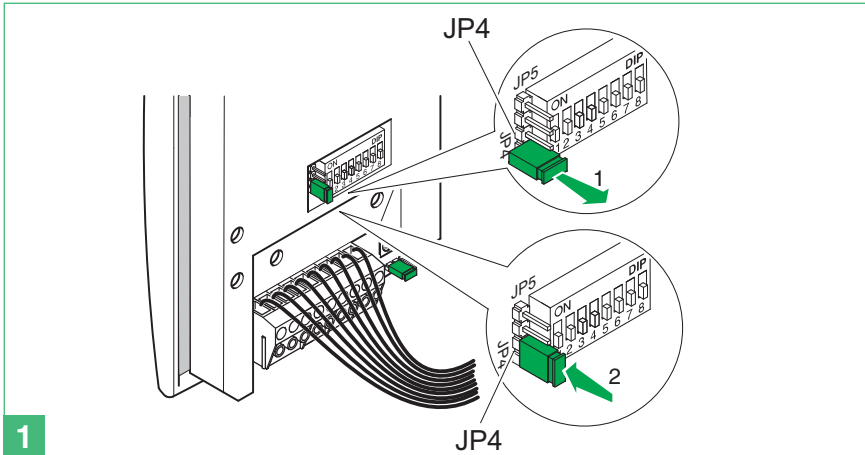

Code	Dip switch ON	
Door lock		
245	1,3,5,6,7,8	Door lock time: 2 sec. + disabling tone (default)
246	2,3,5,6,7,8	Door lock confirmation tone: enabled
247	1,2,3,5,6,7,8	Door lock time: 8 sec.
252	3,4,5,6,7,8	Lock-release always enabled (default)
253	1,3,4,5,6,7,8	Lock-release only enabled for user called

System functions		
243	1,2,5,6,7,8	Reset wait time: 10 sec. (default)
244	3,5,6,7,8	Reset wait time: 1 sec.
248	4,5,6,7,8	Call transmission: single (default)
249	1,4,5,6,7,8	Call transmission: triple

254	2,3,4,5,6,7,8	Restore default
-----	---------------	------------------------

A number of special programming operations can be carried out on Art. 4882, in accordance with the various system requirements.

1. Enter programming mode by positioning the JP4 jumper (Fig. 1) vertically.
2. Set the code corresponding to the function you wish to program on the dip-switches (Fig. 2), in accordance with the table on page 33.
3. Confirm the selected function by moving the jumper from JP3 to the JP5 position (Fig. 3) and wait until you hear a confirmation tone.
4. To carry out further special programming, remove the jumper from JP5 and repeat the steps described in points 2 and 3.
5. When the procedure is complete, set the jumpers back to their initial positions (Fig. 4): the JP4 jumper in a horizontal position and the second jumper from JP5 to the JP3 position.

Avertissements

- Effectuer l'installation en suivant scrupuleusement les instructions fournies par le constructeur et conformément aux normes en vigueur.
- Tous les appareils doivent être strictement destinés à l'emploi pour lequel ils ont été conçus. La société **Comelit Group S.p.A.** décline toute responsabilité en cas de mauvais usage des appareils, pour des modifications effectuées par d'autres personnes pour n'importe quelle raison et pour l'utilisation d'accessoires et matériaux non d'origine.
- Tous les produits sont conformes aux prescriptions de la directive 2006/95/CE (qui remplace la directive 73/23/CEE et amendements successifs), avec marquage **CE**.
- Éviter de placer les fils de montant à proximité des câbles d'alimentation (230/400V).
- Ne jamais introduire d'objets, ni verser de liquides, à l'intérieur du dispositif.
- Les interventions d'installation, de montage et d'assistance aux appareils électriques doivent être effectuées exclusivement par des électriciens spécialisés.
- Couper l'alimentation avant d'effectuer toute opération d'entretien.
- Relier le cadre porte-modules à la terre (voir Fig.).
- Ne pas maintenir le crochet phonie enfoncé lorsque le combiné est décroché.
- La caméra ne doit pas être installée face à de fortes sources de lumière ni dans des lieux où la personne filmée est fortement à contre-jour. Pour résoudre le problème précédemment décrit, il est conseillé de modifier la hauteur d'installation de la caméra, normalement à 160 - 165 cm, en la plaçant à une hauteur de 180 cm et d'orienter l'objectif vers le bas de manière à améliorer la qualité des prises de vue.
- Les caméras avec capteur CCD couleurs présentent, dans des conditions de mauvaise luminosité, une sensibilité inférieure par rapport aux caméras en noir et blanc. Par conséquent, dans les milieux faiblement éclairés, il est conseillé de prévoir une source d'éclairage supplémentaire.



FR

Généralités	35
Poste extérieur	35
Art. 4882	35
Art. 1205/B	35
Installation poste extérieur	36
Postes Intérieurs	37
Montage poste intérieur Magis	37
Retrait du moniteur	37
Art. 6402E	38
Description moniteur	38
Art. 2608	39
Installation combiné parlophonique Art. 2608	39
Indications générales d'installation et fonctionnement	40
Tableau distances de fonctionnement	40
Fonctionnement	40
Description programmations et fonctions boutons	41
Réglage du moniteur Réf. 6402E et du combiné parlophonique Style	41
TAB. A Adresse de montant	41
Description fonctions	41
Moniteurs supplémentaires principaux ou secondaires	42
Configuration des boutons par défaut	42
Recommandations générales pour la programmation des boutons	42
Programmation des boutons pour actionneur générique ou particulier	43
Programmation pour appel intercommunicant	43
Programmation/effacement adresse intercommunicant (uniquement pour l'appel intercommunicant sélecteur)	43
TAB. B Adresses intercommunicant sélecteur	43
Programmation des boutons pour appel intercommunicant	44
Programmation des boutons pour d'autres fonctions	44
TAB. C Adresse de montant	45
Reset de programmation	45
Programmation range/sonneries	46
Programmation de l'entrée IN1 pour signal led/alarme/ouvre-porte/actionneur	47
Programmation directe appel intercommunicant	48
Variation sonnerie moniteur	48
Programmations spéciales Art.4882	49
Schémas de connexion	
MSK/012C Schéma base pour kit un usager Art. 8471MC. Mise en service/vérification tensions d'installation au repos.	114
MSK/017AC Schéma pour kit un usager Art. 8471MC amplifié par un second Art. 4882	115
MSK/012/AC Schéma pour kit un usager avec alimentateur complémentaire Art. 1395	116
MSK/015C Emploi module caméra déportée Art. 1259C.....	117
SB2/AAR Connexion amplificateur vidéo Art. 4833C.....	118
MSK/HCA Adjonction d'un moniteur principal en parallèle. Connexion en cascade	118
MSK/IC Adjonction d'un moniteur principal en parallèle. Connexion en dérivation	119
MSK/A20S Connexion en cascade du troisième moniteur principal avec alimentation locale	119
MSK/A23S Connexion en dérivation de 2 moniteurs principaux et de 2 moniteurs secondaires avec le même code usager.....	120
MSK/A21S Connexion en cascade de 2 moniteurs principaux et de 1 moniteur secondaire avec le même code usager	120
MSK/AAE Connexion combinés parlophoniques supplémentaires en dérivation du moniteur	121
MSK/AAD Connexion combinés parlophoniques supplémentaires en cascade du moniteur	121
MSK/FC Adjonction d'un combiné parlophonique en parallèle en dérivation du montant.....	122
SB/X3 Utilisation pour usages divers du bouton P1 (Art. 2608)	122
SB2V/AAK Connexion de dispositifs de répétition d'appel (Art. 1229 ou Art. 1122/A).....	123
Variante connexion appel palier	123

Utilisation de l'entrée IN1 comme contact pour signal LED/ALARME/OUVRE-PORTE/ACTIONNEUR. Activation en fermeture vers CFP2	124
Utilisation de l'entrée IN1 comme contact pour signal LED/ALARME/OUVRE-PORTE/ACTIONNEUR. Activation en présence de tension par rapport à IN2..	124
SB2/AAM2 Utilisation pour usages divers du bouton P1	125
SMK/EC Branchement relais actionneur Art.1256	125
GK/AAGC Variante pour connecter le bouton de commande de gâche local temporisé	126
SMK/SNP Variante avec gâche de sécurité et alimentation supplémentaire	126
Utilisation du réseau RC pour filtre gâche sur les contacts du relais	127

Généralités

Les kits parlophoniques et visiophoniques à un usager Art. 8471MC peuvent être utilisés dans des bâtiments privés ou tertiaires dans lesquels un contrôle efficace des accès est demandé face à de simples opérations d'installation.

En effet, 2 conducteurs suffisent entre le poste extérieur et le/s moniteur/s intérieur/s pour activer le système (appel, phonie, vidéo, auto-allumage) plus 2 fils pour alimenter le poste extérieur et la gâche électrique et 2 fils pour alimenter le poste intérieur visiophonique.

En outre, une vaste gamme d'accessoires est disponible pour résoudre facilement chaque exigence d'installation ; en effet, outre des accessoires intéressants de type standard, il est possible d'agrandir l'installation en ajoutant des portiers vidéo et/ou des interphones et/ou des postes extérieurs.

Il est ainsi possible d'ajouter au maximum 2 postes extérieurs avec 4 postes intérieurs entre combinés parlophoniques et moniteurs visiophoniques pour la version un usager.

Avec une configuration spécifique, on peut effectuer des communications intercommunicantes un usager (c'est-à-dire entre les usagers possédant le même code) en utilisant tant les moniteurs visiophoniques que les combinés parlophoniques.

Plusieurs kits peuvent être reliés à un port principal Simplebus et/ou à un standard Art. 1998A.

Poste extérieur

Art. 4882

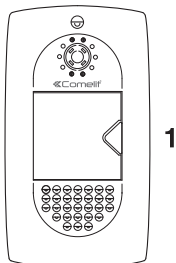

Art. 1205/B

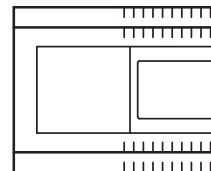

Caractéristiques techniques

Connexion au moniteur avec 2 fils pour audio, vidéo, ouvre-porte et appel plus 2 fils pour alimentation par Art. 1205/B.

Caméra orientable à haute sensibilité avec capteur CCD 1/3".

Éclairage à Leds blanches (6 LED).

Étiquettes porte-noms avec éclairage à led.

Églage du volume du micro et du haut-parleur.

Dimensions boîtier à encastrer : 176,5x95,5x35 mm.

Le bouton de l'Art.4882 est réglé en usine pour effectuer l'appel à l'adresse 1.

Dimensions poste extérieur : 176x95x15 mm.

Description bornier

LL connexion moniteur (vidéo, appel, phonie, ouvre-porte).

RTE entrées ouvre-porte local temporisé.

~ ~ alimentation poste extérieur.

SE. NC. - SE NO. - SE C. connexion gâche électrique.

Caractéristiques techniques

Le transformateur prévoit 2 sorties : une pour alimenter le poste extérieur et la gâche électrique, et une pour alimenter le moniteur.

Dimensions : 105x85x85 mm (6 modules DIN).

Fusible de protection 500 mA retardé.

Description bornier

230 V CA entrée tension de réseau.

~~ sortie CA pour poste externe et électro-serrure.

+ - sortie 20 V CC d'alimentation du moniteur.

Installation poste extérieur

FR

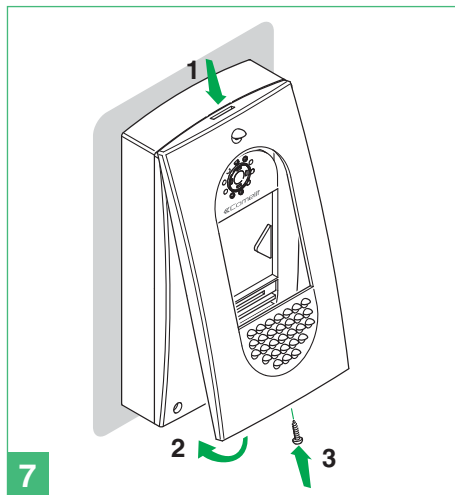
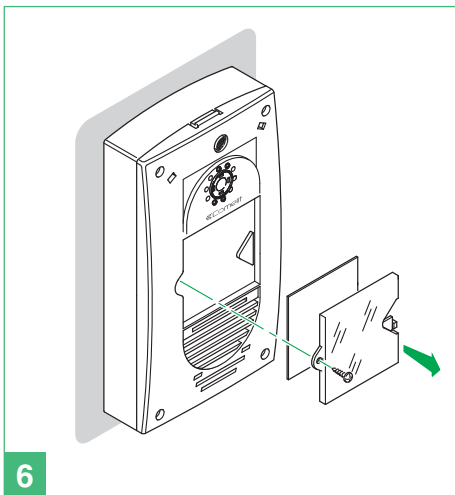
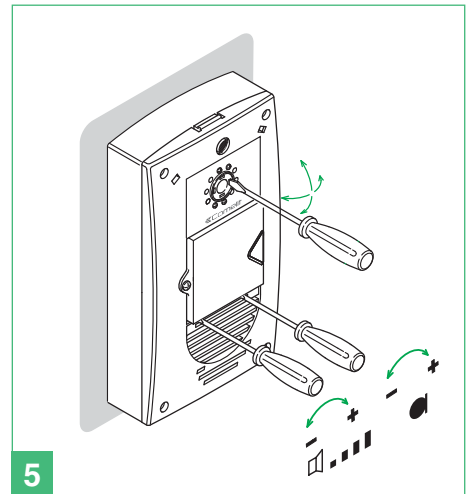
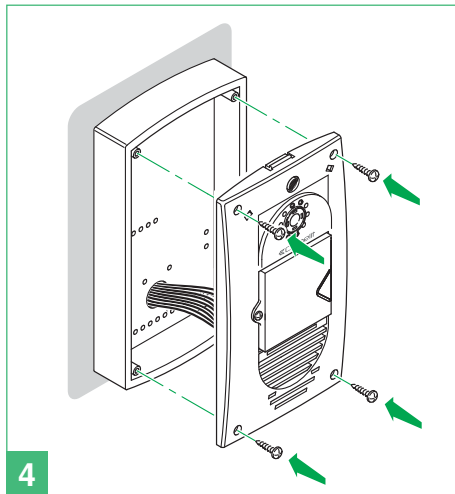
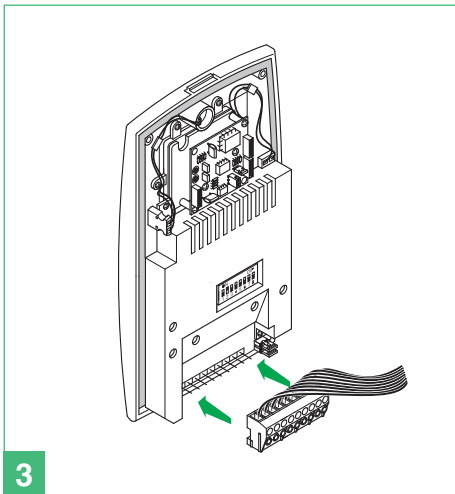
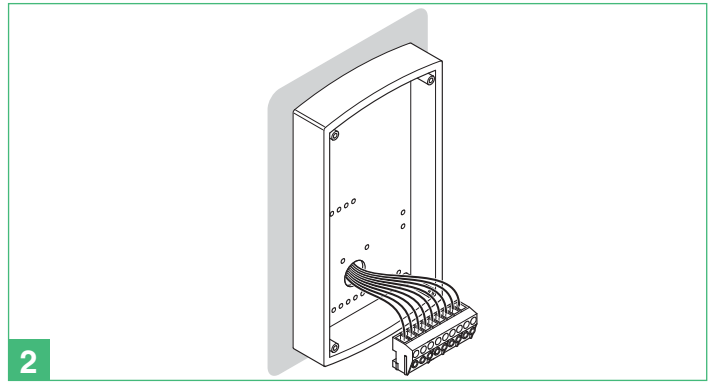
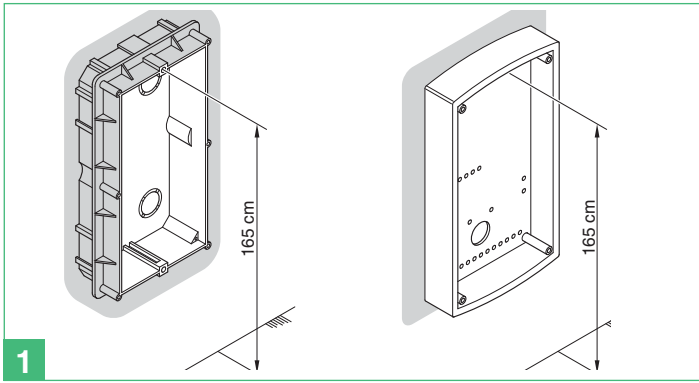
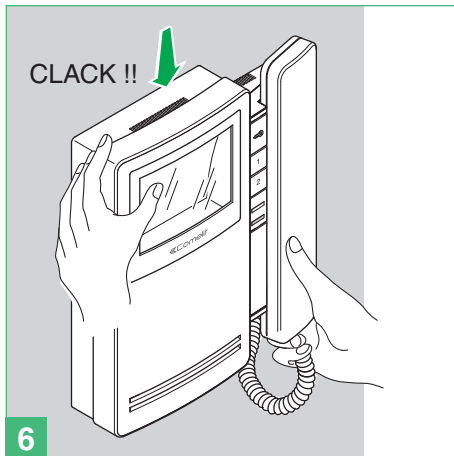
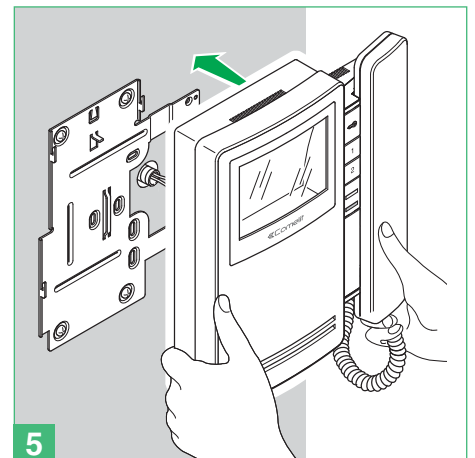
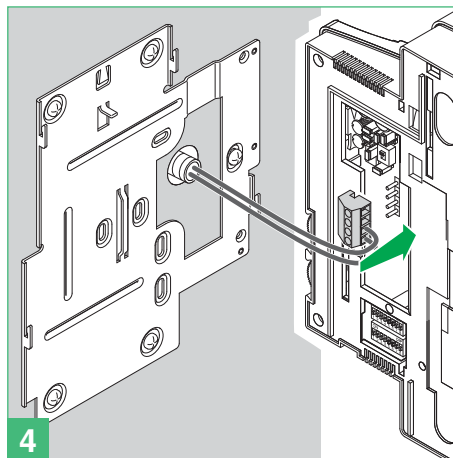
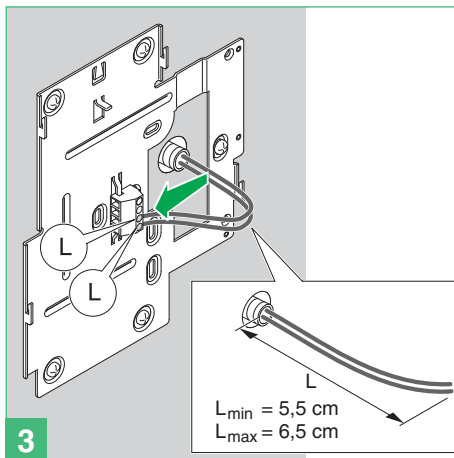
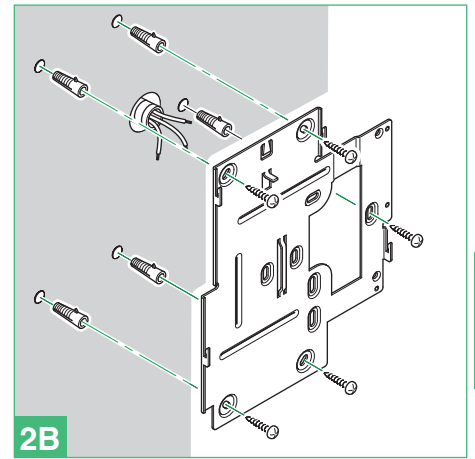
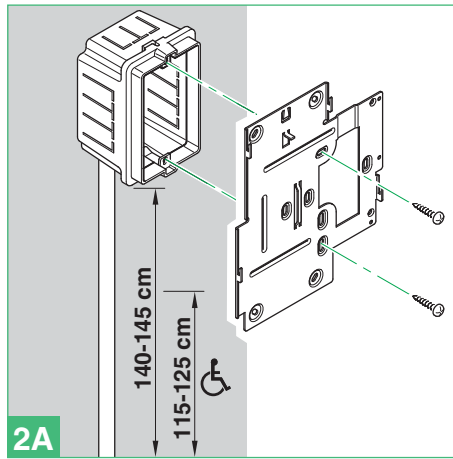
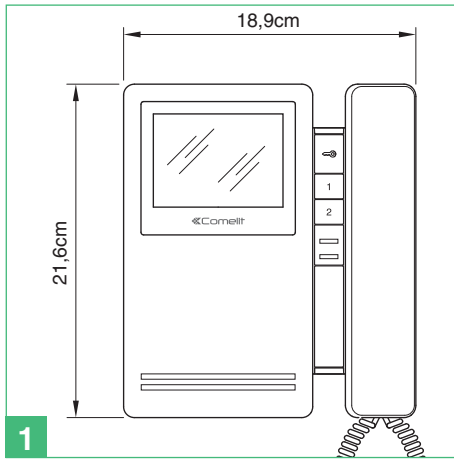

Fig. 4 - REMARQUE Avant de fixer les 4 vis, vérifier s'il est nécessaire de procéder à la programmation des fonctions spéciales page 49.

Fig. 5 - REMARQUE Desserrer légèrement les quatre vis pour débloquer l'orientation de la caméra.

Montage poste intérieur Magis



Retrait du moniteur

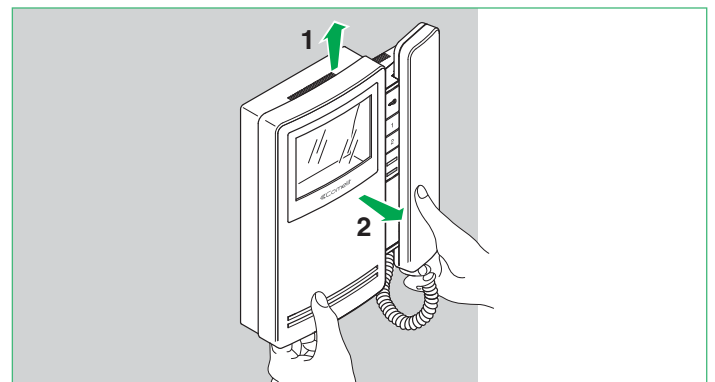

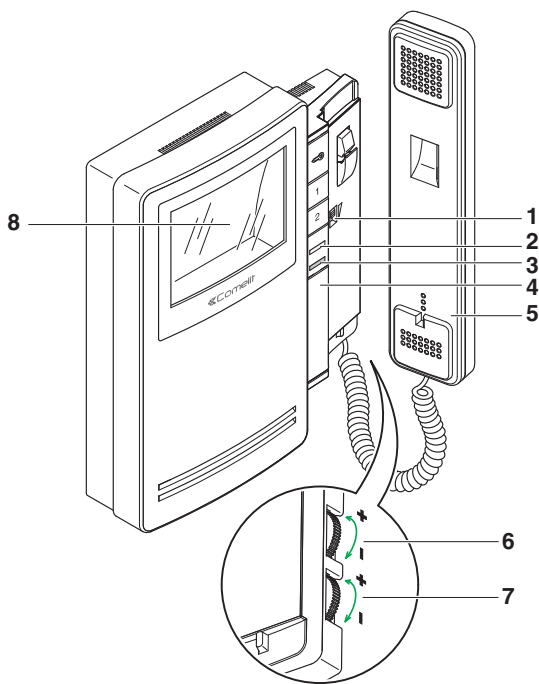

Description moniteur :

- 1 Réglage volume appel / sélecteur fonction Privé (par service Privé, on entend l'exclusion de l'appel depuis la plaque de rue et des combinés parlophoniques ou visiophones intercommunicants ; l'activation du service Privé est indiquée par l'apparition d'un indicateur rouge à côté du sélecteur).
- 2 Led de signalisation installation occupée/fonction docteur ON/porte ouverte.
- 3 Témoin rouge - privacy validée.
- 4 Espace logement boutons supplémentaires avec accessoire Art. 6333, Art. 6434.
- 5 Combiné Moniteur (soulever le combiné pour commencer la communication).
- 6 Bouton de réglage de l'intensité de la couleur.
 - ▶ Pour augmenter la valeur, tourner dans le sens inverse des aiguilles d'une montre.
- 7 Bouton de réglage de la luminosité.
 - ▶ Pour augmenter la valeur, tourner dans le sens inverse des aiguilles d'une montre.
- 8 Écran 3,5" couleurs.

Description boutons :

- ☞ Bouton ouvre-porte,
- 1 Touche 1 actionneur générique (programmable).
- 2 Touche 2 auto-allumage (programmable).

Description moniteur

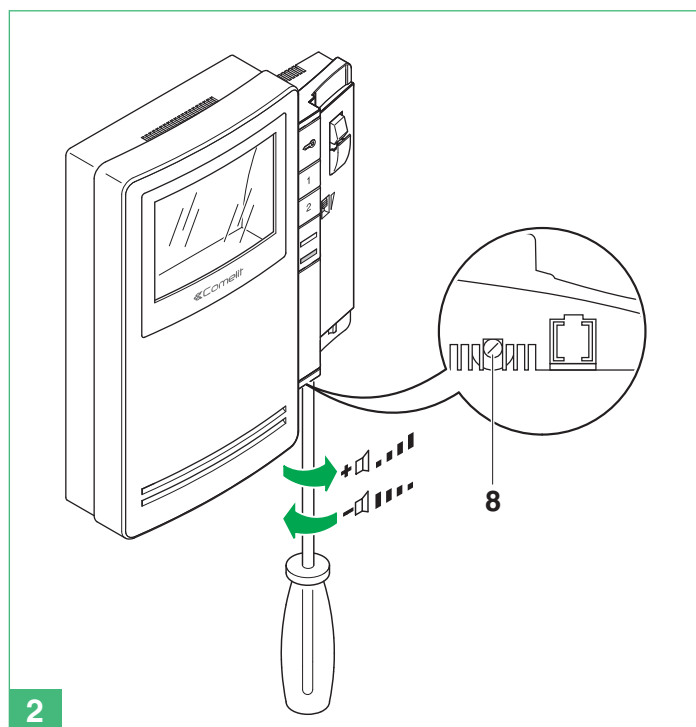
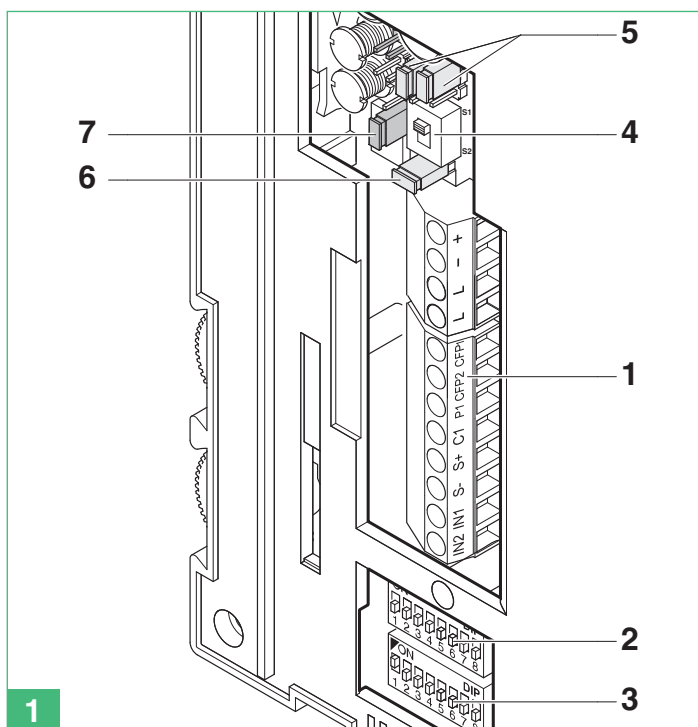

- 1 Bornier pour la connexion de l'installation :
 - + - Bornes pour alimentation.
 - L L Bornes de connexion ligne Bus.
 - CFP1 CFP2 Entrée de l'appel palier.
 - P1 C1 Bornes bouton 1 pour services divers.
 - Pour avoir un contact C.NO. (24V-100mA maxi), déplacer les cavaliers CV3 et CV4 sur la position B.**
 - S+ S- Bornes pour le dispositif de répétition de l'appel.
 - IN1 IN2 Entrée LED (programmable).
- 2 S1 Microswitches pour la programmation du code utilisateur.
- 3 S2 DIP switches de programmation des boutons et fonctions (identifié par un coin rouge) :
 - DIP 1-2-3-4 de programmation des fonctions des boutons.
 - DIP 5-6 accès à la programmation.
 - DIP 7 de gestion de la tension d'alimentation (voir schémas et variantes page 114) défaut = OFF.

- DIP 8:
 - ON étrier secondaire.
 - OFF étrier principal (défaut).
- 4 SW3 Sélecteur pour modalité Simplebus 1 (S1 - défaut) ou Simplebus 2 (S2).
- 5 CV3 CV4 Cavalier pour libérer le bouton 1 (contact C.NO. 24V-100mA maxi).
 - A bouton 1 actionneur générique (par défaut) ou programmable.
 - B bouton 1 pour usages divers.
- 6 CV5 Cavalier débranchement.
- 7 CV6 sélecteur pour l'utilisation de l'entrée IN 1 (voir page 124).
- 8 Réglage du volume du haut-parleur (uniquement pour le réglage de la phonie d'intercommunication).

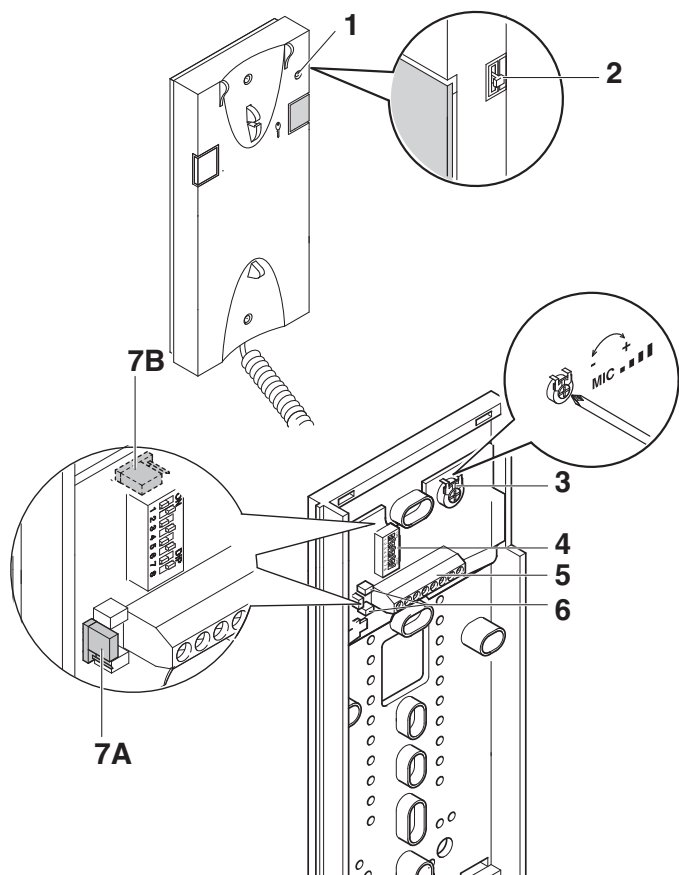

Non utilisable pour la fonction intercommunicante.
Le combiné parlophonique doit toujours être monté en utilisant l'Art. 1214/2C comme indiqué par le schéma de branchement MSK/FC page 122.

- 1 Voyant fonction Privacy.
- 2 Sélecteur sonnerie / service Privacy à 3 positions :
Position haute : Sonnerie volume maximum.
Position centrale : Sonnerie volume moyen.
Position basse : Activation fonction Privacy.
(Le Service Privé exclut l'appel du poste extérieur ou du standard de conciergerie ; l'activation de la fonction Privé est indiquée par l'apparition d'un voyant rouge en haut à droite).
- 3 Potentiomètre de réglage du volume du microphone.
- 4 Micro-interrupteurs pour programmation code usager.
- 5 Bornes pour le raccordement de l'installation :
L L Connexion à la ligne bus.
CFP CFP Entrée de l'appel palier.
P1 C1 Bornes bouton P1 pour services divers (contact C.NO, 24V-100mA max) (retirer CV1 et CV2, voir variante SB/X3 page 122).
S+ S- Bornes pour le dispositif de répétition de l'appel.
- 6 CV1 CV2 Cavalier à retirer pour avoir un contact libre C.NO. sur le bouton P1.
- 7A/7B JP1 cavalier pour sélectionner la fonction appel standard (position C)/Actionneur générique (position A) du bouton P1.

Description boutons :

- ↔ Bouton ouvre-porte.
- P1 Bouton P1 appel standard/actionneur générique/bouton pour usages divers présent en bornier (P1 C1).

Nettoyer avec un chiffon humidifié avec de l'eau. Éviter d'utiliser de l'alcool ou d'autres produits agressifs.

Installation combiné parlophonique Art. 2608

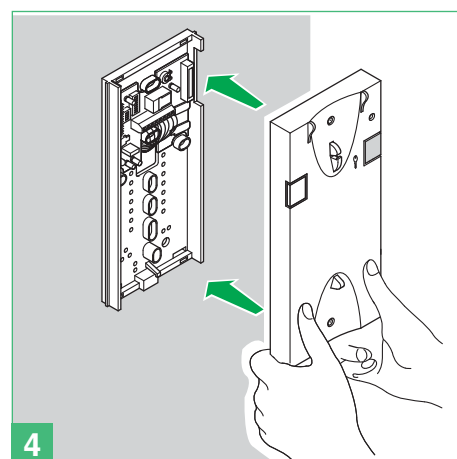
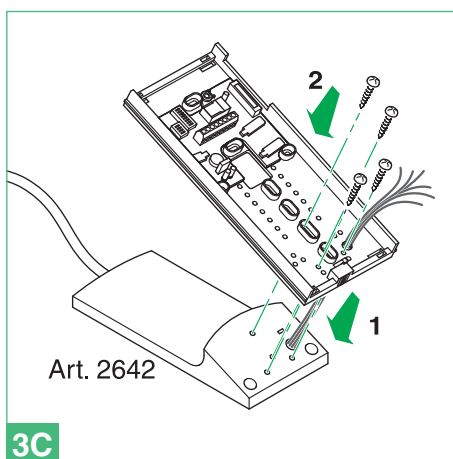
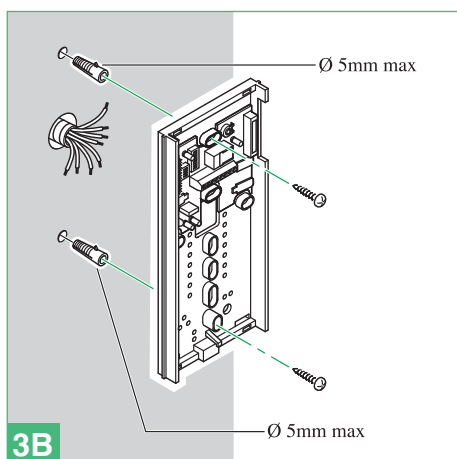
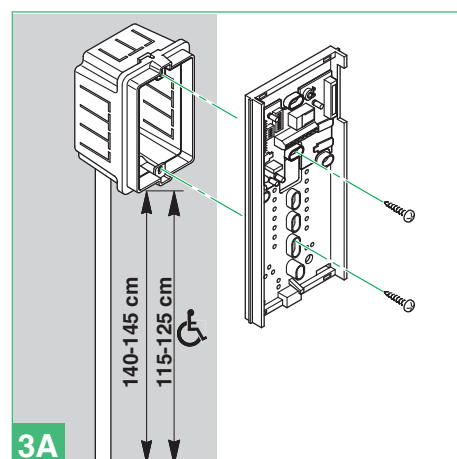
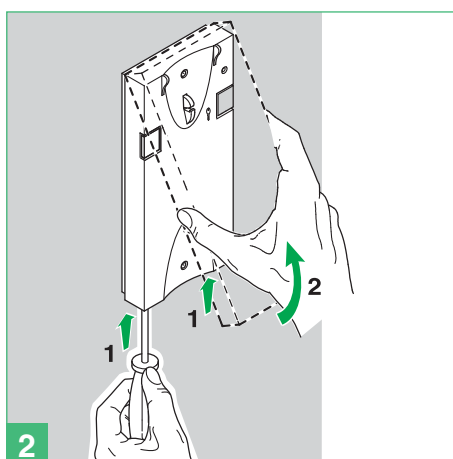
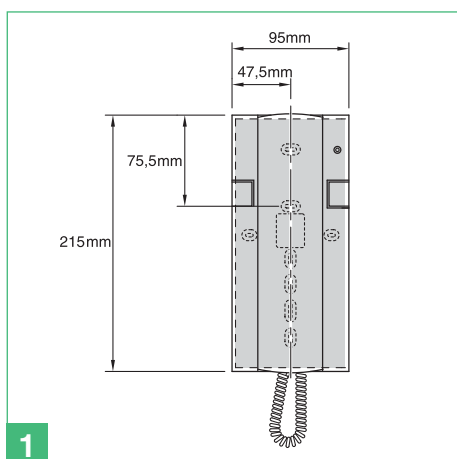

Indications générales d'installation et fonctionnement

La distance maximum totale entre le poste extérieur et le moniteur le plus éloigné est de 400 m (avec amplificateur Réf. 4833C).
 La somme du nombre de postes intérieurs ayant le même code usager et du nombre de dispositifs de répétition d'appel branchés à ces postes intérieurs ne peut pas être supérieure à 4.
 Brancher un seul dispositif de répétition d'appel pour chaque poste intérieur.
 La distance MAX de la connexion entre le poste intérieur et le dispositif de répétition d'appel est de 20m ; pour la connexion, utiliser un câble blindé et ne pas faire passer les câbles à proximité de charges inductives lourdes ou de câbles d'alimentation (230V / 400V).

Tableau distances de fonctionnement

		A/G MAX	B/E MAX	C MAX	D MAX	F MAX	Art. 1216
Comelit Art. 4577 1 mm ² (Ø 1,2 mm AWG 17)		50 m (165 feet)	50 m (165 feet)	200 m (655 feet)	100 m (330 feet)	150 m (495 feet)	
Comelit Art. 4576-4578	0,5 mm ² (Ø 0,8 mm AWG 20) bus		25 m (85 feet)	200 m (655 feet)	100 m (330 feet)	150 m (495 feet)	
	1,5 mm ² (Ø 1,4 mm AWG 15) power	75 m (245 feet)	100 m (330 feet)				
UTP5 cat. 5 0,2 mm ² (Ø 0,5 mm AWG 24)				190 m (625feet)	60 m (195 feet)	150 m (495 feet)	
0,28 mm ² (Ø 0,6 mm AWG 23)		5 m (15 feet)		190 m (625 feet)	60 m (195 feet)	150 m (495 feet)	
0,5 mm ² (Ø 0,8 mm AWG 20)		25 m (85 feet)	25 m (85 feet)	190 m (625 feet)	60 m (195 feet)	150 m (495 feet)	
1 mm ² (Ø 1,2 mm AWG 17)		50 m (165 feet)	50 m (165 feet)	190 m (625 feet)	60 m (195 feet)	150 m (495 feet)	
1 mm ² (Ø 1,2 mm AWG 17)		50 m (165 feet)	50 m (165 feet)	120 m (395 feet)	40 m (130 feet)	100 m (330 feet)	
1,5 mm ² (Ø 1,4 mm AWG 15)		75 m (245 feet)	100 m (330 feet)	190 m (625 feet)	60 m (195 feet)	150 m (495 feet)	
2,5 mm ² (Ø 1,8 mm AWG 13)		100 m (330 feet)	150 m (495 feet)	190 m (625 feet)	60 m (195 feet)	150 m (495 feet)	

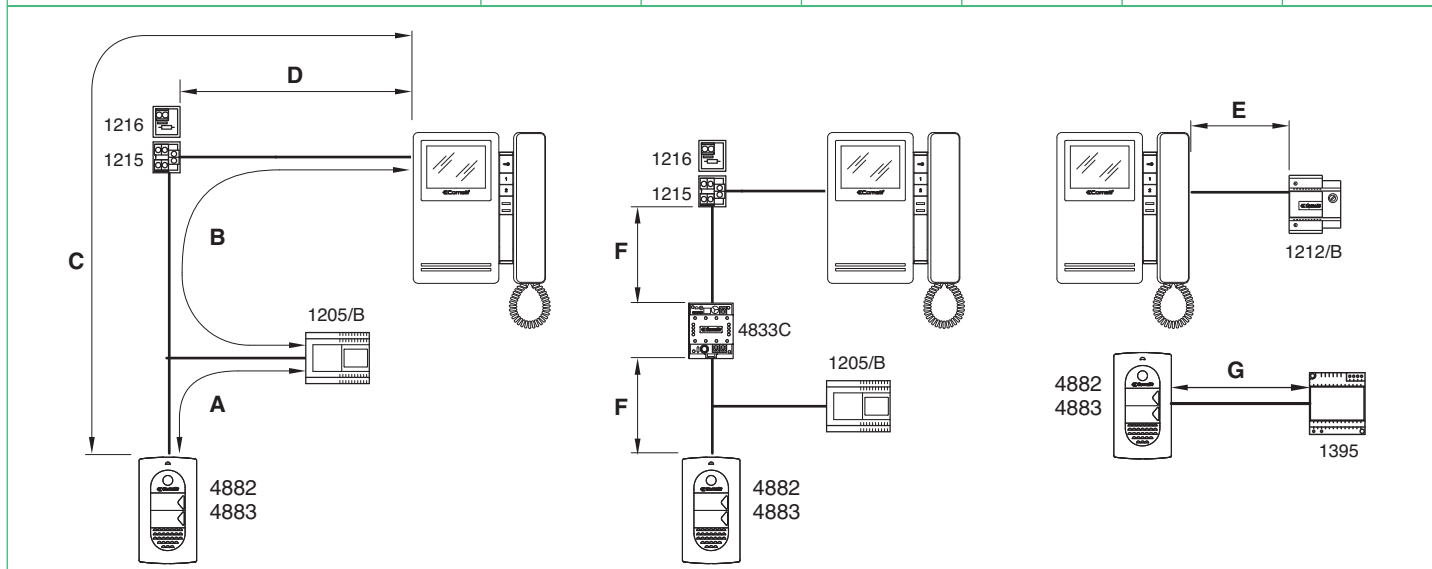

Fonctionnement



En cas de court-circuit persistant sur la ligne bus, le poste extérieur émet un signal sonore intermittent d'avertissement.

Lorsque le visiteur appuie sur le bouton d'appel, les leds blanches s'allument pour éclairer la personne, la sonnerie interne d'appel s'enclenche (si la fonction privé n'est pas validée) et l'image s'affiche au moniteur principal ou aux moniteurs principaux, pendant environ 60".

La durée maximum de la conversation entre poste extérieur et poste intérieur est de 90".

Sur le poste extérieur on a une tonalité d'appel ; lorsque, dans les installations à 2 entrées ou plus, au moment de l'appel le poste extérieur émet une tonalité d'occupé au lieu de la sonnerie, cela signifie qu'une autre conversation est en cours vers un autre poste extérieur.

Pour la programmation d'adresses usagers différentes de celles programmées d'origine (1 et 2), voir page 41.

Pour les fonctions d'intercommunication du système Magis KIT, voir la page 43.

Description programmations et fonctions boutons

Réglage du moniteur Réf. 6402E et du combiné parlophonique Style

Position des dip-switches du moniteur Réf. 6402E

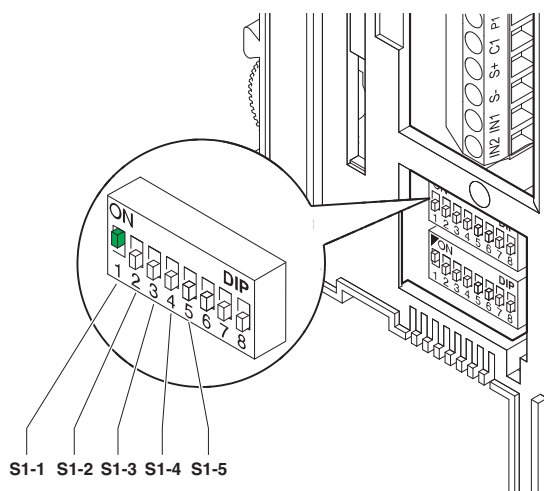

► Sur les combinés parlophoniques Art. 2608, Art. 2610 et Art. 2628 placer les dips **S1-6, S1-7, S1-8** sur **OFF**.

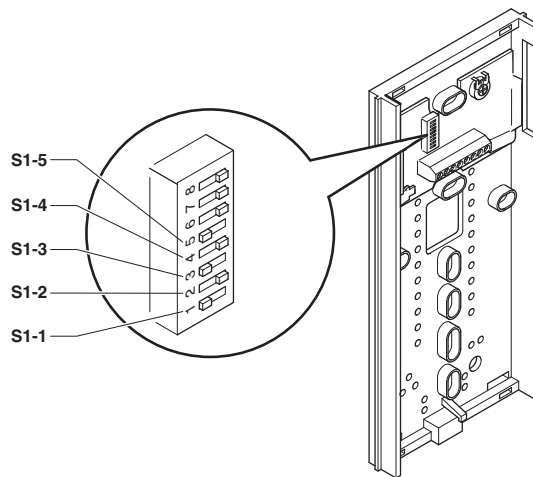

Les valeurs de **S1-1, S1-2, S1-3, S1-4** et **S1-5** définissent l'**adresse d'appel** du moniteur et des combinés parlophoniques, comme indiqué dans le tableau ci-après.

TAB. A Adresse de montant

Code	S1
1	

Description fonctions

☞ **Ouvre-porte** : La pression du bouton Ouvre-porte active la serrure reliée à la plaque de rue.

Actionneur : La pression du Bouton 1 programmé dans la modalité Actionneur permet d'activer l'Art. 1256 qui peut être utilisé par exemple pour activer l'ouverture de portails, portes basculantes ou pour l'activation du module caméras cycliques Art. 1259C.

Bouton Libre : L'indication Bouton libre indique la possibilité d'utiliser le bouton comme contact C.NO en bornier au moyen de programmations opportunes comme illustré dans la variante SB2/AAM2 pag. 125.

Autoallumage/demande vidéo

- ✓ L'auto-allumage peut être invalidé.
- ✓ L'auto-allumage n'est possible que lorsque l'installation est en veille.
- ✓ Conseillé uniquement pour les installations avec 1 ou 2 entrées.

La pression du bouton 2 dans cette modalité permet de visualiser sur l'écran du moniteur l'image transmise depuis le poste extérieur même si aucun appel n'a été effectué.

Dans les installations équipées de 2 postes externes, il est possible de visualiser alternativement l'image depuis un poste extérieur ou depuis l'autre (fonction "basculer") en appuyant plusieurs fois sur le bouton 2.

Sur moniteurs secondaires (DIP 8 de S2 sur ON) le bouton 2 a également la fonction de demande vidéo, qui permet d'allumer un moniteur suite à un appel de poste extérieur.

Activation :

- appuyer le bouton dédié à l'auto-allumage du moniteur pendant un temps dépassant 4 sec.
- » sonnerie de confirmation.

Désactivation :

- appuyer le bouton dédié à l'auto-allumage du moniteur pendant un temps dépassant 4 sec.
- » 4 tonalités de confirmation.

Allumage :

- appuyer sur le bouton 2 et le relâcher immédiatement (si les programmations faites à l'usine ont été maintenues).

Appel au standard

Appuyer sur le bouton réglé sur cette modalité pour envoyer un appel au standard de conciergerie de l'installation.

Appel intercommunicant un usager

Cette fonction permet d'envoyer un appel aux autres appareils (moniteurs visiophoniques et/ou combinés parlophoniques) programmés sur la même adresse d'appel.

- En saisissant le combiné, le destinataire de l'appel engage la communication avec l'appelant. La communication prend fin lorsque le combiné est raccroché.

Un appel intercommunicant n'est pas prioritaire sur une conversation/un appel avec le poste extérieur.

Dans ce cas, lors d'une tentative d'appel intercommunicant, la led clignote pendant quelques secondes pour indiquer que le système est occupé.

Appel depuis le poste extérieur

Un appel provenant d'un poste extérieur est toujours prioritaire sur une communication intercommunicante (l'activation de la communication avec le poste extérieur interrompt la conversation intercom en cours).

Dans ce cas, les utilisateurs déjà en communication entendent dans le combiné un signal sonore similaire à un signal d'appel si ce dernier leur est destiné, ou un triple signal sonore dans le cas contraire.

- Pour prendre l'appel provenant du poste extérieur, il suffit de saisir le combiné d'une unité disponible ou de raccrocher, puis de saisir le combiné d'une unité occupée par une communication intercommunicante.

Docteur

Cette fonction permet d'actionner automatiquement l'ouvre-porte sur appel extérieur à l'adresse du poste intérieur sur lequel la fonction a été activée.

Validation / Invalidation :

- appuyer pendant 2 sec. le bouton spécifique de cette fonction.
- » Lorsque la fonction est active, la led de signalisation reste allumée.

Moniteurs supplémentaires principaux ou secondaires

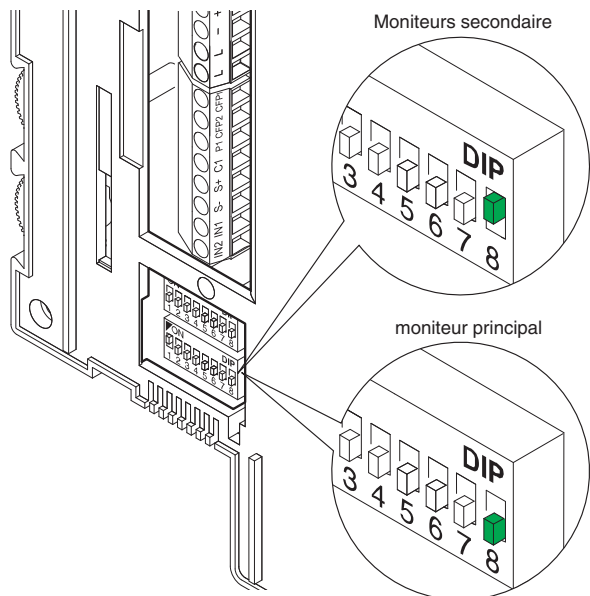

La programmation du DIP 8 de S2 définit si la bride en objet sera gérée comme principale (P) ou comme secondaire (S).

Le poste extérieur peut gérer jusqu'à un maximum de 4 visiophones ou parlophones par bouton d'appel.

Dans la configuration classique de Magis KIT, on peut donc avoir au maximum 2 visiophones principaux et 2 visiophones secondaire par bouton d'appel, tous alimentés par le même **Art.1205/B**.

On a la possibilité de gérer jusqu'à 3 visiophones principaux au sein de la même unité familiale (c'est-à-dire programmés sur le même code usager). Dans cette configuration particulière, les visiophones principaux supplémentaires devront être alimentés chacun par l'**Art. 1212/B** (voir variante MSK/HCA, MSK/IC page. 118, 119).

Lorsque l'on effectue un appel depuis le poste extérieur, le moniteur que le système allumera sera celui du visiophone principal.

Les autres moniteurs secondaires de la même unité familiale resteront éteints.

En répondant à l'appel du poste extérieur depuis un moniteur visiophonique secondaire, l'image est automatiquement visualisée sur le moniteur.

À ce stade, le moniteur visiophonique principal s'éteint et l'image s'affiche au moniteur visiophonique sur lequel on a appuyé sur le bouton 2 - auto-allumage/demande vidéo.

Pour visualiser l'image sans activer la phonie avec le poste extérieur, appuyer sur le bouton 2 - auto-allumage/demande vidéé.

Configuration des boutons par défaut

DIP S2								avec Art. 6433, 6434			
DIP 1	DIP 2	DIP 3	DIP 4	P1	P2	🔑	☎️	P3	P4	P5	P6
0	0	0	0	CCS	AI			ACT	D	PAN	K
1	0	0	0	ACT	AI			INT	INTb	D	CCS
0	1	0	0	INT	AI			INTb	ACT	CCS	CCP
1	1	0	0	ACT	CCS			CCP	PAN	K	D
0	0	1	0	ACT	ACT	ACT		ACT	ACT	ACT	ACT
1	0	1	0	INT	ACT			CCS	CCP	INTb	PAN
0	1	1	0	AI	D			K	CCS	CCP	INTb
1	1	1	0	INTb	INT			AI	INT	PAN	D
0	0	0	1	CCS	PAN			D	AI	INT	INTb
1	0	0	1	K	CCS			PAN	CCP	AI	INT
0	1	0	1	CCP	K			PAN	ACT	INT	AI
1	1	0	1	PAN	CCP			CCS	K	ACT	D
0	0	1	1	D	INTb			INT	ACT	AI	CCS
1	0	1	1	INT	INT			INT	INT	INT	INT
0	1	1	1	NULL	NULL	NULL	NULL	NULL	NULL	NULL	NULL
1	1	1	1						PROG		

Légende

🔑	Ouvre-porte	CCS	Appel standard	INTb	intercommunicant deux usagers - uniquement pour KIT
☎️	Phonie	K	Appel combiné parlophonique gardien	NULL	Aucune fonction
ACT	Actionneur	D	Docteur	PROG	Fonctions programmées, voir pages 42-43-44-45 Dans cette modalité des dip switches les boutons gèrent les fonctions programmées ; les boutons NON programmés commandent les fonctions signalées à la ligne 0000
AI	Auto-allumage	PAN	Panique		
CCP	Appel standard principal	INT	Intercommunicant programmable, général ou sélecteur - de série appel un usager pour KIT et Simplebus Top		



Recommandations générales pour la programmation des boutons

Au cas où les configurations par défaut (voir tableau page 42) ne répondraient pas à vos besoins, vous pouvez modifier la programmation des boutons en suivant les procédures décrites ci-après.

Une fois la procédure terminée, placer les DIP 1-2-3-4 de S2 en combinaison 1111 (réglage PROG dans les tableaux de configuration page 42-43-44-

45). Lorsque les dip sont ainsi configurés, les boutons gouvernent les fonctions programmées ; les boutons NON programmés commandent les fonctions signalées à la ligne 0000 (voir tableau page 42). Rétablir sur S1 la configuration du code usager, voir tableau A page 41.

Programmation des boutons pour actionneur générique ou particulier

DIP S2								avec Art. 6433, 6434				DIP S1	
DIP 1	DIP 2	DIP 3	DIP 4	P1	P2			P3	P4	P5	P6	ADRESSE ON 1 2 3 4 5 6 7 8	
0	0	0	0					ACT					
1	0	0	0	ACT									
0	1	0	0						ACT				
1	1	0	0	ACT									
0	0	1	0	ACT	ACT	ACT		ACT	ACT	ACT	ACT		
1	0	1	0		ACT								
0	1	1	0										
1	1	1	0										
0	0	0	1										
1	0	0	1										
0	1	0	1						ACT				
1	1	0	1							ACT			
0	0	1	1										
1	0	1	1										
0	1	1	1										
1	1	1	1										

Exemple :

sur moniteur avec code usager 5 programmation P1= actionneur générique, P2= actionneur particulier avec code 125.

1. Placer DIP 5-6 de S2 en combinaison 01.

» la Led (verte) clignote.

2. Consulter le tableau page 43 et choisir une combinaison qui affiche la fonction actionneur (ACT) pour les boutons qui doivent être programmés.

ex : pour P1= actionneur générique, programmer DIP 1-2-3-4 de S2 en combinaison 1000 ou 1100 ou 0010 (P1=ACT), programmer DIP de S1 en combinaison 11111111, passer au point 3.

ex : pour P2= actionneur particulier avec code 125, programmer DIP 1-2-3-4 de S2 en combinaison 0010 ou 1010 (P2=ACT), programmer S1 avec adresse 125 conformément au **tableau C** page 45, passer au point 3.

3. Appuyer sur le bouton puis le relâcher pour associer la fonction.

» la Led (verte) s'allume.

» tonalité de confirmation dans le combiné.

4. Pour quitter la programmation, mettre les DIP 5-6 de S2 en combinaison 00

» la Led (verte) s'éteint.

5. Au terme de la programmation, mettre les DIP 1-2-3-4 de S2 en combinaison 1111. Rétablir sur S1 la configuration du code usager, voir tableau A page 41.

Programmation pour appel intercommunicant



Appel intercommunicant général et sélecteur **NE SONT PAS** compatibles sur le même montant.

Programmation/effacement adresse intercommunicant (uniquement pour l'appel intercommunicant sélecteur)

1)	2)						3)	
S1	DIP 1	DIP 2	DIP 3	DIP 4	DIP 5	DIP 6	S2	
Programmation; programmer code, TAB. B page 43	0	0	0	1	1	1	 ON 1 2 3 4 5 6 7 8	 1
Effacement ON 1 2 3 4 5 6 7 8	1	1	1	1	1	1	 ON 1 2 3 4 5 6 7 8	 2 2 sec



Prendre note de la configuration de **S2, S1** et la rétablir à la fin de la programmation.

TAB. B Adresses intercommunicant sélecteur

Code	Dip switch ON	S1	Code	Dip switch ON	S1	Code	Dip switch ON	S1
1	1		4	4		7	7	
2	2		5	5		8	8	
3	3		6	6				

Il est nécessaire de programmer l'adresse intercommunicante sur tous les postes intérieurs de la colonne montante.

Il est possible d'associer la même adresse intercommunicante à 3 postes intérieurs maximum.

Pour un appel de groupe sélectionner simultanément les codes intercommunicants voulus(max 3).

Programmation des boutons pour appel intercommunicant

DIP S2								avec Art. 6433, 6434				DIP S1	
DIP 1	DIP 2	DIP 3	DIP 4	P1	P2			P3	P4	P5	P6	ADDRESS 	
0	0	0	0										
1	0	0	0					INT	INTb				
0	1	0	0	INT				INTb					
1	1	0	0										
0	0	1	0										
1	0	1	0	INT						INTb			
0	1	1	0	INTb	INT				INT		INTb		
0	0	0	1							INT	INTb		
1	0	0	1								INT		
0	1	0	1							INT			
1	1	0	1					INT					
1	0	1	1	INT	INT			INT	INT	INT	INT		
0	1	1	1										
1	1	1	1										
PROG													

Exemple 1 - Intercommunicant sélecteur

sur moniteur avec code usager 1 et adresse intercommunicant 1 programmation P3= intercommunicant sélecteur avec adresse 2, P4= intercommunicant sélecteur avec adresse 3.

Exemple 2 - KIT intercommunicant

(intercommunicant entre 2 adresses contiguës dans la plage de 1 à 30 dont la première est impaire) :

sur moniteur avec code usager 1 programmation P3= appel général interne, P4= intercommunicant 2 usagers avec adresse 2.

1. Placer DIP 5-6 de S2 en combinaison 01.

» la Led (verte) clignote.

2. Consulter le tableau page 44 et choisir une combinaison qui affiche la fonction appel intercommunicant (INT ou INTb) pour les boutons qui doivent être programmés.

ex 1 : pour P3= intercommunicant sélecteur, programmer DIP 1-2-3-4 de S2 en combinaison 1000 ou 0011 ou 1011 (P3=INT), programmer S1 avec adresse 2 conformément au **tableau B** page 43, passer au point 3.

ex 1 : pour P4= intercommunicant sélecteur, programmer DIP 1-2-3-4 de S2 en combinaison 1110 ou 1011 (P4=INT), programmer S1 avec adresse 3 conformément au **tableau B** page 43, passer au point 3.

ex 2 : pour P3= appel général interne et P4=intercommunicant 2 usagers, programmer DIP 1-2-3-4 de S2 en combinaison 1000 (P3=INT, P4=INTb), programmer S1 avec code usager 1 conformément au **tableau A** page 41, passer au point 3.

3. Appuyer sur le bouton puis le relâcher pour associer la fonction.

» la Led (verte) s'allume.

» tonalité de confirmation dans le combiné.

4. Pour quitter la programmation, mettre les DIP 5-6 de S2 en combinaison 00.

» la Led (verte) s'éteint.

5. Au terme de la programmation, mettre les DIP 1-2-3-4 de S2 en combinaison 1111. Rétablir sur S1 la configuration du code usager, voir **tableau A** page 41.

Programmation des boutons pour d'autres fonctions

DIP S2								avec Art. 6433, 6434			
DIP 1	DIP 2	DIP 3	DIP 4	P1	P2			P3	P4	P5	P6
0	0	0	0	CCS	AI				D	PAN	K
1	0	0	0		AI					D	CCS
0	1	0	0		AI					CCS	CCP
1	1	0	0		CCS			CCP	PAN	K	D
0	0	1	0								
1	0	1	0					CCS	CCP		PAN
0	1	1	0	AI	D			K	CCS	CCP	PAN
1	1	1	0					AI		PAN	D
0	0	0	1	CCS	PAN			D	AI		
1	0	0	1	K	CCS			PAN	CCP	AI	
0	1	0	1	CCP	K			PAN			AI
1	1	0	1	PAN	CCP			CCS	K		D
0	0	1	1	D						AI	CCS
1	0	1	1								
0	1	1	1	NULL	NULL	NULL	NULL	NULL	NULL	NULL	NULL
PROG											

Légende

	Ouvre-porte	CCS	Appel standard	NULL	Aucune fonction
	Phonie	K	Appel combiné parlophonique gardien	PROG	Fonctions programmées
AI	Auto-allumage	D	Docteur		
CCP	Appel standard principal	PAN	Panique		

Exemple :

sur moniteur avec code usager 5 programmation P5= auto-allumage, P6=appel au standard.

1. Placer DIP 5-6 de S2 en combinaison 01.

» la Led (verte) clignote.

2. Consulter le tableau page 44 et choisir une combinaison qui affiche les fonctions choisies/nécessaires pour les boutons qui doivent être programmés.

ex : pour P5= auto-allumage P6= appel au standard, programmer DIP 1-2-3-4 de S2 en combinaison 0011 (P5=AI, P6=CCS).

3. Appuyer sur le bouton puis le relâcher pour associer la fonction.

» la Led (verte) s'allume.

» tonalité de confirmation dans le combiné.

4. Pour quitter la programmation, mettre les DIP 5-6 de S2 en combinaison 00.

» la Led (verte) s'éteint.

5. Au terme de la programmation, mettre les DIP 1-2-3-4 de S2 en combinaison 1111.

TAB. C Adresse de montant

Code	Dip switch ON	Code	Dip switch ON	Code	Dip switch ON	Code	Dip switch ON	Code	Dip switch ON	Code	Dip switch ON	Code	Dip switch ON	Code	Dip switch ON
1	1	31	1,2,3,4,5	61	1,3,4,5,6	91	1,2,4,5,7	121	1,4,5,6,7	151	1,2,3,5,8	181	1,3,5,6,8	211	1,2,5,7,8
2	2	32	6	62	2,3,4,5,6	92	3,4,5,7	122	2,4,5,6,7	152	4,5,8	182	2,3,5,6,8	212	3,5,7,8
3	1,2	33	1,6	63	1,2,3,4,5,6	93	1,3,4,5,7	123	1,2,4,5,6,7	153	1,4,5,8	183	1,2,3,5,6,8	213	1,3,5,7,8
4	3	34	2,6	64	7	94	2,3,4,5,7	124	3,4,5,6,7	154	2,4,5,8	184	4,5,6,8	214	2,3,5,7,8
5	1,3	35	1,2,6	65	1,7	95	1,2,3,4,5,7	125	1,3,4,5,6,7	155	1,2,4,5,8	185	1,4,5,6,8	215	1,2,3,5,7,8
6	2,3	36	3,6	66	2,7	96	6,7	126	2,3,4,5,6,7	156	3,4,5,8	186	2,4,5,6,8	216	4,5,7,8
7	1,2,3	37	1,3,6	67	1,2,7	97	1,6,7	127	1,2,3,4,5,6,7	157	1,3,4,5,8	187	1,2,4,5,6,8	217	1,4,5,7,8
8	4	38	2,3,6	68	3,7	98	2,6,7	128	8	158	2,3,4,5,8	188	3,4,5,6,8	218	2,4,5,7,8
9	1,4	39	1,2,3,6	69	1,3,7	99	1,2,6,7	129	1,8	159	1,2,3,4,5,8	189	1,3,4,5,6,8	219	1,2,4,5,7,8
10	2,4	40	4,6	70	2,3,7	100	3,6,7	130	2,8	160	6,8	190	2,3,4,5,6,8	220	3,4,5,7,8
11	1,2,4	41	1,4,6	71	1,2,3,7	101	1,3,6,7	131	1,2,8	161	1,6,8	191	1,2,3,4,5,6,8	221	1,3,4,5,7,8
12	3,4	42	2,4,6	72	4,7	102	2,3,6,7	132	3,8	162	2,6,8	192	7,8	222	2,3,4,5,7,8
13	1,3,4	43	1,2,4,6	73	1,4,7	103	1,2,3,6,7	133	1,3,8	163	1,2,6,8	193	1,7,8	223	1,2,3,4,5,7,8
14	2,3,4	44	3,4,6	74	2,4,7	104	4,6,7	134	2,3,8	164	3,6,8	194	2,7,8	224	6,7,8
15	1,2,3,4	45	1,3,4,6	75	1,2,4,7	105	1,4,6,7	135	1,2,3,8	165	1,3,6,8	195	1,2,7,8	225	1,6,7,8
16	5	46	2,3,4,6	76	3,4,7	106	2,4,6,7	136	4,8	166	2,3,6,8	196	3,7,8	226	2,6,7,8
17	1,5	47	1,2,3,4,6	77	1,3,4,7	107	1,2,4,6,7	137	1,4,8	167	1,2,3,6,8	197	1,3,7,8	227	1,2,6,7,8
18	2,5	48	5,6	78	2,3,4,7	108	3,4,6,7	138	2,4,8	168	4,6,8	198	2,3,7,8	228	3,6,7,8
19	1,2,5	49	1,5,6	79	1,2,3,4,7	109	1,3,4,6,7	139	1,2,4,8	169	1,4,6,8	199	1,2,3,7,8	229	1,3,6,7,8
20	3,5	50	2,5,6	80	5,7	110	2,3,4,6,7	140	3,4,8	170	2,4,6,8	200	4,7,8	230	2,3,6,7,8
21	1,3,5	51	1,2,5,6	81	1,5,7	111	1,2,3,4,6,7	141	1,3,4,8	171	1,2,4,6,8	201	1,4,7,8	231	1,2,3,6,7,8
22	2,3,5	52	3,5,6	82	2,5,7	112	5,6,7	142	2,3,4,8	172	3,4,6,8	202	2,4,7,8	232	4,6,7,8
23	1,2,3,5	53	1,3,5,6	83	1,2,5,7	113	1,5,6,7	143	1,2,3,4,8	173	1,3,4,6,8	203	1,2,4,7,8	233	1,4,6,7,8
24	4,5	54	2,3,5,6	84	3,5,7	114	2,5,6,7	144	5,8	174	2,3,4,6,8	204	3,4,7,8	234	2,4,6,7,8
25	1,4,5	55	1,2,3,5,6	85	1,3,5,7	115	1,2,5,6,7	145	1,5,8	175	1,2,3,4,6,8	205	1,3,4,7,8	235	1,2,4,6,7,8
26	2,4,5	56	4,5,6	86	2,3,5,7	116	3,5,6,7	146	2,5,8	176	5,6,8	206	2,3,4,7,8	236	3,4,6,7,8
27	1,2,4,5	57	1,4,5,6	87	1,2,3,5,7	117	1,3,5,6,7	147	1,2,5,8	177	1,5,6,8	207	1,2,3,4,7,8	237	1,3,4,6,7,8
28	3,4,5	58	2,4,5,6	88	4,5,7	118	2,3,5,6,7	148	3,5,8	178	2,5,6,8	208	5,7,8	238	2,3,4,6,7,8
29	1,3,4,5	59	1,2,4,5,6	89	1,4,5,7	119	1,2,3,5,6,7	149	1,3,5,8	179	1,2,5,6,8	209	1,5,7,8	239	1,2,3,4,6,7,8
30	2,3,4,5	60	3,4,5,6	90	2,4,5,7	120	4,5,6,7	150	2,3,5,8	180	3,5,6,8	210	2,5,7,8	*240	5,6,7,8

*REMARQUE : le code 240 est réservé au standard de conciergerie

Reset de programmation

! 1)	! 2)						3)	4)
S1	DIP 1	DIP 2	DIP 3	DIP 4	DIP 5	DIP 6	S2	S1/S2/LED1
<p>DIP ON</p>	1	1	1	1	1	1	<p>5 sec</p>	<p>2 sec</p>
<p>Configurations d'usine :</p> <ul style="list-style-type: none"> • Fonctions des boutons selon la combinaison DIP 1-2-3-4 de S2 ; • Adresse intercommunicant absente ; • Fonction range et adresses mini et maxi absentes ; • Reset sonneries ; • Entrée IN 1 => LED (défaut). 								<p>Prendre note de la configuration de S2, S1 et la rétablir à la fin de la programmation.</p>

FR

Effectuer les opérations de 1 à 4											
Programmation range/sonneries	! 1)		! 2)						3)		4)
	S1		DIP 1	DIP 2	DIP 3	DIP 4	DIP 5	DIP 6	S2	S1/S2/LED1	
Adresse range minimum			0	0	0	0	1	0			
Adresse range maximum	programmer code, TAB. C page 45		0	0	0	0	0	0			
Validation range											
Désactivation range											
Sélection de la sonnerie polyphonique			0	1	0	1	1	0			
Sélection de la sonnerie tonalités (défaut)			0	1	0	1	1	0			

Effectuer les opérations de 1 à 4															
		! 1)					! 2)					3)		4)	
		S1					S2							S1/S2/LED1	
		DIP 1	DIP 2	DIP 3	DIP 4	DIP 5	DIP 6								
Programmation de l'entrée IN1 pour signal led/ alarme/ouvre-porte/actionneur															
Entrée IN 1 ⇒ LED (défaut), voir pages 124		0	0	0	1	1	0								
Entrée IN 1 ⇒ ALARME, voir pages 124		0	0	0	1	1	0								
Entrée IN 1 ⇒ OUVRE-PORTE, voir pages 124		0	0	0	1	1	0								
Entrée IN 1 ⇒ ACTIONNEUR PARTICULIER, voir pages 124		0	0	1	0	1	0								
Entrée IN 1 ⇒ ACTIONNEUR GÉNÉRIQUE, voir pages 124		0	0	1	0	1	0								

! Prendre note de la configuration de S2, S1 et la rétablir à la fin de la programmation.

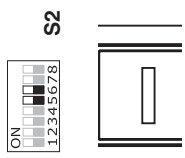
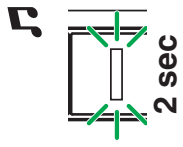

Programmation directe appel intercommunicant

Permet la programmation des appels intercommunicants directement depuis les postes intérieurs.

✓ Nécessite la présence de 2 opérateurs.

Phase 1 : entrée en programmation

L'opérateur 1 et l'opérateur 2 effectuent les opérations suivantes sur 2 postes intérieurs :

1. Configurer DIP 1-2-3-4 de S2 en combinaison 1111.

2. Décrocher le combiné.

3. Appuyer 3 secondes sur les touches 1 et 2 .

» *Le poste intérieur émet 1 tonalité.*

» *La Led verte clignote.*

» *Le poste intérieur se met en phonie.*

» *À ce stade, les 2 opérateurs sont en communication entre eux.*

Phase 2 : programmation appel intercommunicant

Opérateur 1 :

▶ Il appuie sur le bouton qu'il veut programmer pour appeler l'opérateur 2 (ex. 2).

» *Le poste intérieur de l'opérateur 1 émet une tonalité de confirmation.*

Opérateur 2 :

▶ Il appuie sur le bouton qu'il veut programmer pour appeler l'opérateur 1 (ex. 1).

» *Le poste intérieur de l'opérateur 2 émet une tonalité de confirmation.*

Opérateur 1/Opérateur 2 :

▶ Raccrocher le combiné.

» *Le poste intérieur émet 1 tonalité.*

» *La programmation des 2 postes intérieurs est terminée.*

Pour programmer un autre poste intérieur, passer à la PHASE 3.

Phase 3 : Programmation d'autres postes intérieurs

Opérateur 1/Opérateur 2 :

1. Une fois le nouveau poste atteint, il effectue la phase 1 pour entrer en communication.

2. Répéter la phase 2.

REMARQUE Si l'on reçoit un appel durant la programmation, il est nécessaire de répondre à l'appel puis de reprendre la phase de programmation.

Variation sonnerie moniteur

1. Maintenir appuyé le bouton  jusqu'à ce qu'une tonalité de confirmation soit audible (cette opération n'est possible que lorsque le système est en condition de repos ; dans le cas contraire, la led de signalisation clignote pour avertir l'utilisateur).

2. Appuyer et relâcher le bouton  :

1 fois (émission d'une tonalité de confirmation) pour modifier la sonnerie d'appel depuis le poste extérieur.

2 fois (émission de 2 tonalités de confirmation) pour modifier la sonnerie depuis standard.

3 fois (émission de 3 tonalités de confirmation) pour modifier la sonnerie d'appel intercommunicant depuis un poste intérieur.

4 fois (émission de 4 tonalités de confirmation) pour modifier la sonnerie de l'appel palier.

Appuyer ultérieurement sur le bouton  pour répéter la séquence décrite ci-dessus.

3. Appuyer et relâcher le bouton 1 pour écouter les diverses sonneries disponibles l'une après l'autre.

4. Appuyer sur le bouton 2 pour confirmer la sélection de la dernière tonalité que vous avez entendue et pour quitter (à tout moment) le mode de sélection sonnerie moniteur. Une tonalité de confirmation vous avertira que vous avez quitté la modalité de variation de la sonnerie moniteur.

Programmations spéciales Art.4882

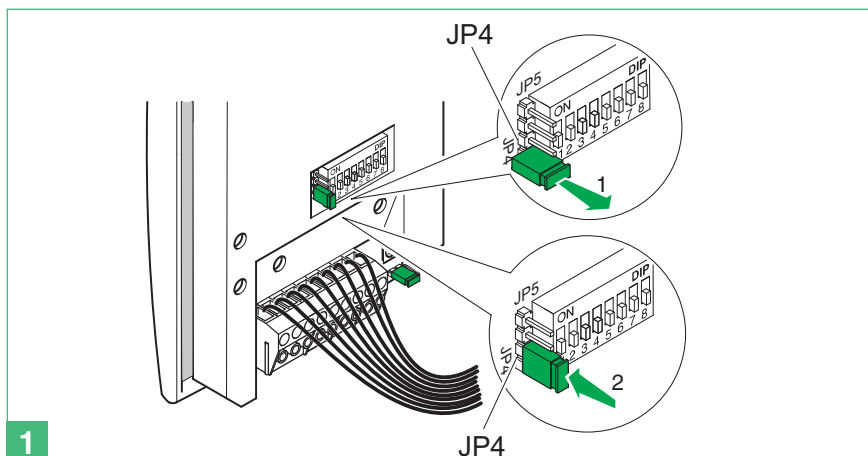

1

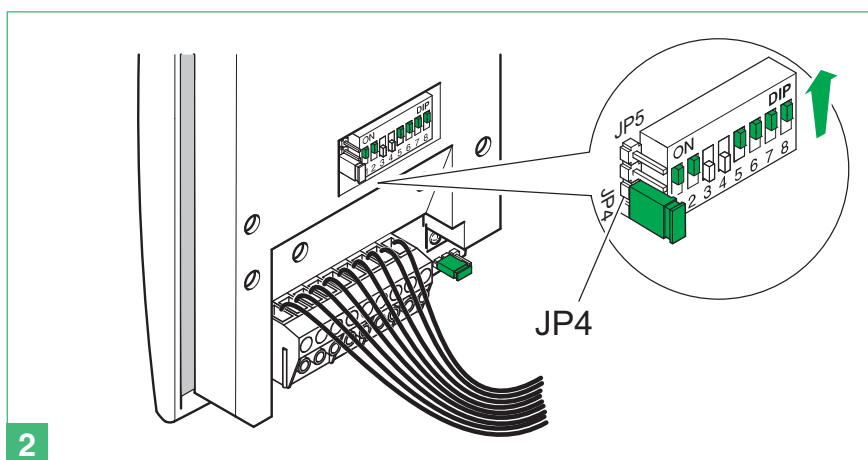

2

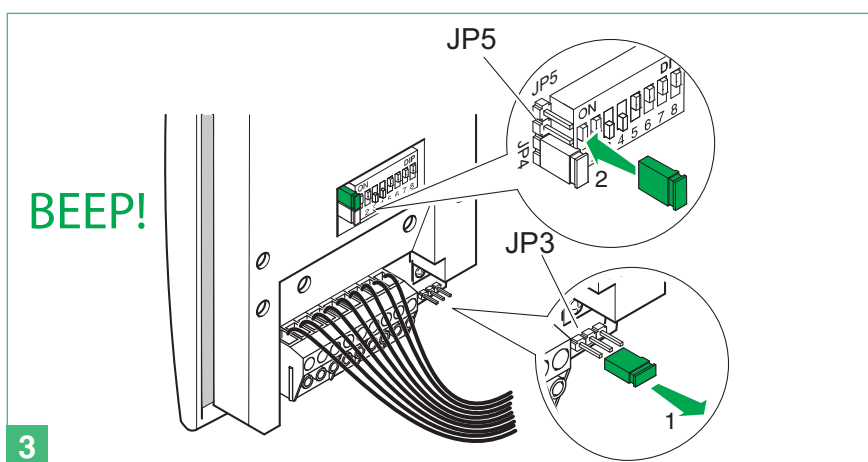

3

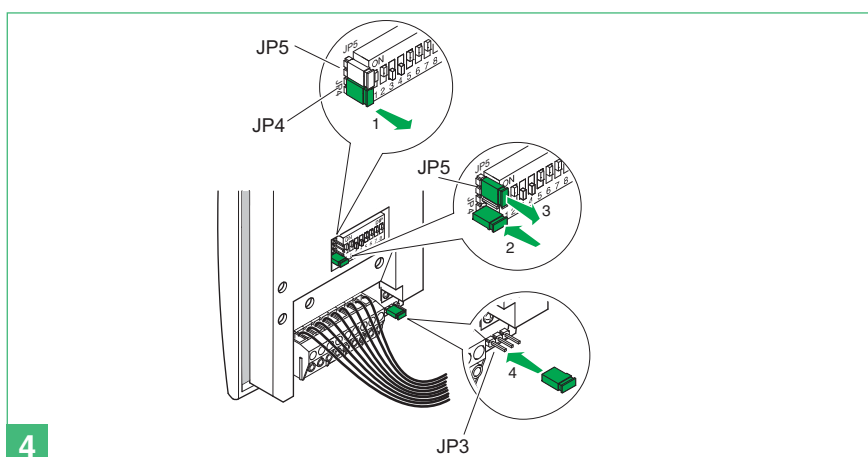

4

Code	Dip switch ON	Gâche
245	1,3,5,6,7,8	Temps gâche : 2 sec + tonalité désactivée (par défaut)
246	2,3,5,6,7,8	Tonalité confirmation gâche : actif
247	1,2,3,5,6,7,8	Temps gâche : 8 sec
252	3,4,5,6,7,8	Ouvre-porte toujours actif (par défaut)
253	1,3,4,5,6,7,8	Ouvre-porte actif uniquement pour usager appelé

Fonctions installation		
243	1,2,5,6,7,8	Temps d'attente reset : 10 sec (par défaut)
244	3,5,6,7,8	Temps d'attente reset : 1 sec
248	4,5,6,7,8	Envoi appel : unique (default)
249	1,4,5,6,7,8	Envoi appel : triple

Rétablissement réglage d'usine		
254	2,3,4,5,6,7,8	

Sur les Art. 4882, il est possible d'effectuer une série de programmations spéciales en fonction des différentes exigences d'installation.

1. Entrer en mode de programmation en positionnant à la verticale le cavalier JP4 (Fig. 1).
2. Définir sur les DIP switches le code correspondant à la fonction que l'on désire programmer (Fig. 2), selon le tableau page 49.
3. Confirmer la fonction programmée en déplaçant le cavalier de JP3 en position JP5 (Fig. 3) et attendre la tonalité de confirmation.
4. Pour effectuer une autre programmation spéciale, enlever le cavalier de JP5 et répéter les opérations décrites aux points 2 et 3.
5. À la fin de la procédure, repositionner les cavaliers dans leur position initiale (Fig. 4) : le cavalier JP4 en position horizontale et le second cavalier de JP5 en position JP3.

Waarschuwingen

- Voer de installatiewerkzaamheden zorgvuldig uit volgens de door de fabrikant gegeven instructies en met inachtneming van de geldende normen. Alle componenten mogen alleen gebruikt worden voor de doeleinden waarvoor ze zijn ontworpen. **Comelit Group S.p.A.** is niet verantwoordelijk voor oneigenlijk gebruik van de apparatuur, voor wijzigingen die om welke reden dan ook door derden zijn aangebracht, en voor het gebruik van accessoires en materialen die niet door de fabrikant zijn aangeleverd.
- Alle producten voldoen aan de eisen van de richtlijn 2006/95/EG (die de richtlijn 73/23/EEG en latere wijzigingen vervangt). Dit wordt bevestigd door het **CE**-label op de producten
- Monteer de aders van de stamleiding niet in de nabijheid van voedingskabels (230/400V).
- Voorkom het binnendringen van vreemde voorwerpen of vloeistoffen in de toestellen.
- De installatie-, montage- en servicewerkzaamheden aan de elektrische apparaten mogen uitsluitend door gespecialiseerde elektriciens worden verricht.
- Onderbreek de voeding, voordat u onderhoudswerkzaamheden uitvoert.
- Sluit het moduleframe op de aardleiding aan (zie afb.).
- Houd de telefoonhaak niet ingedrukt als de hoorn is opgenomen.
- Installeer de camera niet tegenover felle lichtbronnen of op plaatsen waar de opgenomen persoon met de rug naar het licht staat. Om het hierboven beschreven probleem op te lossen, is het raadzaam om de installatiehoogte van de videocamera, die normaal 160 - 165 cm is, te wijzigen naar een hoogte van 180 cm en om de lens naar beneden te richten, zodat de opnamekwaliteit wordt verbeterd.
- Camera's met CCD-kleurensensor hebben in schaars verlichte omstandigheden een lagere gevoeligheid dan zwart-witcamera's. Het wordt daarom aanbevolen om in schaars verlichte omgevingen een extra lichtbron te plaatsen.

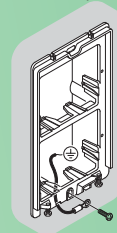

Algemeen	51
Entrepaneel	51
Art. 4882	51
Art. 1205/B	51
Installatie entrepaneel	52
Interne aansluitingen	53
Montage interne aansluiting Magis	53
Verwijderen van de monitor	53
Art. 6402E	54
Beschrijving van de monitor	54
Art. 2608	55
Installatie deurtelefoon Art. 2608	55
Algemene aanwijzingen voor de installatie en de werking	56
Tabel afstanden	56
Werking	56
Beschrijving van de instellingen en werking van de knoppen	57
Instellingen monitor Art. 6402E en Style-intercom	57
TAB. A Adressen van de stamleiding	57
Beschrijving van de functies	57
Extra hoofd- of secundaire monitors	58
Standaardconfiguratie	58
Algemene waarschuwingen voor de programmering van de drukknoppen	58
Programmering drukknoppen voor algemene of geadresseerde relaissturing	59
Programmeringen voor intercomoproep	59
Programmeren/wissen van een intercomadres (enkel voor selectieve intercom)	59
TAB. B Adressen voor selectieve intercom	59
Programmeringen drukknoppen voor intercomoproep	60
Programmering drukknoppen voor andere functies	60
TAB. C Adressen van de stamleiding	61
Reset van de programmering	61
Programmering range/beltonen	62
Programmering ingang IN1 voor signalering led/alarm/deuropener/relais	63
Directe programmering van de intercomoproep	64
Wijzigen van de beltonen van de monitor	64
Speciale programmeringsmogelijkheden Art. 4882	65
Aansluitschema's	
MSK/012C Basisschema pour kits voor eengezinswoningen Art. 8471MC. Inwerkingstelling/spanningscontrole van een systeem in de ruststand..	114
MSK/017AC Schema voor kit eengezinswoning Art. 8471MC uitgebreid met een tweede Art. 4882	115
MSK/012/AC Schema voor kit voor eengezinswoningen met extra voedingstransformator Art. 1395	116
MSK/015C Gebruik module voor externe camera Art. 1259C	117
SB2/AAR Aansluiting van de videoversterker Art. 4833C	118
MSK/HCA Toevoeging van een hoofdmonitor in parallelschakeling. Aansluiting in cascade	118
MSK/IC Toevoeging van een hoofdmonitor. Afgetakte aansluiting	119
MSK/A20S Aansluiting in cascade van een derde hoofdmonitor met individuele voeding	119
MSK/A23S Afgetakte aansluiting van 2 hoofdmonitors en 2 secundaire monitors met dezelfde gebruikerscode	120
MSK/A21S Aansluiting in cascade van 2 hoofdmonitors en 1 secundaire monitor met dezelfde gebruikerscode.....	120
MSK/AAE Aansluiting van extra deurtelefoons afgetakt van de monitor	121
MSK/AAD Aansluiting in cascade van extra deurtelefoons vanaf de monitor	121
MSK/FC Aansluiting in cascade van extra deurtelefoons vanaf de monitor	122
SB/X3 Gebruik voor verschillende doeleinden van drukknop P1 (Art. 2608)	122
SB2V/AAK Aansluiting van een extra bel (Art. 1229 of Art. 1122/A)	123
Variant met aansluiting van een etagebel	123

Gebruik ingang IN1 als contact voor signalering LED/ALARM/DEUROPENER/RELAIS. Activering bij sluiting naar CFP2.....	124
Gebruik ingang IN1 als contact voor signalering LED/ALARM/DEUROPENER/RELAIS. Activering bij aanwezigheid van spanning ten opzichte van IN	124
SB2/AAM2 Gebruik voor verschillende doeleinden van drukknop P1	125
SMK/EC Aansluiting relais module Art. 1256	125
GK/AAGC Variant voor het aansluiten van een lokale deuropener met tijdsinstelling	126
SMK/SNP Variant met veiligheids slot en extra voeding	126
Gebruik van het RC-net voor storingsfilter op de contacten van het relais	127

Algemeen

De video-systeemkits voor eengezinswoningen Art. 8471MC kunnen worden toegepast in woningen of bedrijfspanden waar een doelmatige toegangscontrole nodig is met een eenvoudig te bedienen installatie.

Er zijn slechts 2 aders nodig tussen het entreepaneel en de interne monitor(s) om het systeem te activeren (oproep, intercom, video, beeldoproep), plus 2 draden voor de voeding van het entreepaneel en het elektrische slot en 2 draden voor de voeding van het interne video-intercomtoestel.

Daarnaast is een uitgebreid assortiment accessoires beschikbaar, die een eenvoudige oplossing bieden voor alle eisen die aan de installatie worden gesteld: naast interessante standaardaccessoires, kan de installatie worden uitgebreid met video-intercoms en/of extra deurtelefoons en/of entreepanelen. Op die manier kunnen maximaal 2 entreepanelen met 4 interne aansluitingen gerealiseerd worden waaronder deurtelefoons en video-intercoms voor de eengezinsconfiguratie.

Met geschikte instellingen kunnen eengezinsintercomoproepen gedaan worden (dat wil zeggen tussen gebruikers met dezelfde gebruikerscode) bij gebruik van zowel video-intercoms als deurtelefoons.

Op een Simplebus-hoofdentreepaneel en/of een centrale Art. 1998A kunnen meerdere kits worden aangesloten.

Entreepaneel

Art. 4882

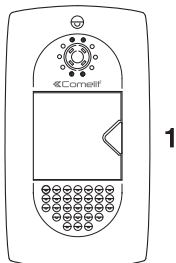

Art. 1205/B

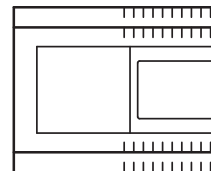

Technische gegevens

Aansluiting op de monitor met 2 draden voor audio, video, deuropener en oproepen plus 2 draden voor voeding vanaf Art. 1205/B.

Instelbare camera met hoge gevoeligheid en 1/3" CCD-sensor.

Verlichting met witte leds (6 LED).

Naambordjes met verlichting met leds.

Volumeregeling van microfoon en luidspreker.

Afmeting inbouwdoos: 176,5x95,5x35 mm.

De toets van Art. 4882 is in de fabriek ingesteld om een oproep te doen aan adres 1.

Afmeting entreepaneel: 176x95x15 mm.

Beschrijving van het aansluitblok

LL aansluiting monitor (video, oproep, audioverbinding, deuropener).

RTE ingang lokale deuropener met tijdsinstelling.

~ ~ voeding entreepaneel.

SE. NC. - SE NO. - SE C. aansluiting elektrisch slot.

Technische gegevens

De transformator heeft 2 uitgangen: één voor de voeding van het entreepaneel en het elektrische slot en één voor de voeding van de monitor.

Afmetingen: 105x85x85 mm (6 DIN-modulen).

Vertraagde zekering 500mA.

Beschrijving van het aansluitblok

AC230V ingresso tensione di rete.

~ ~ uscita AC per posto esterno e elettroserratura.

+ - uscita 20V DC di alimentazione del monitor.

Installatie entreepaneel

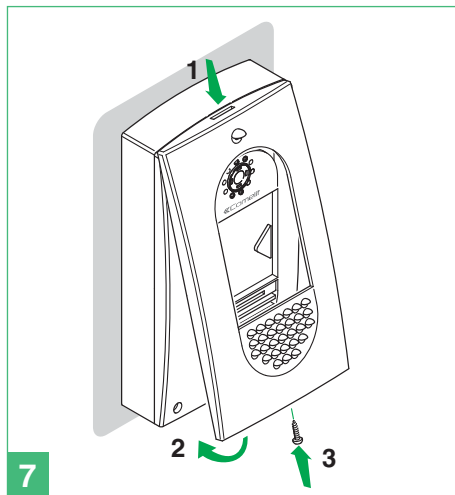
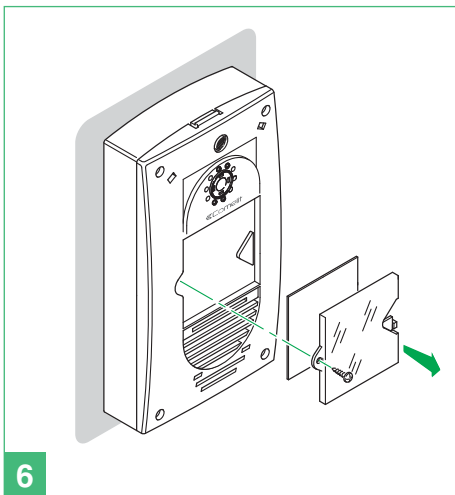
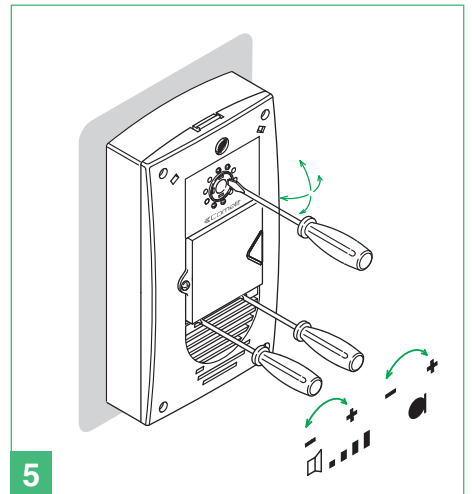
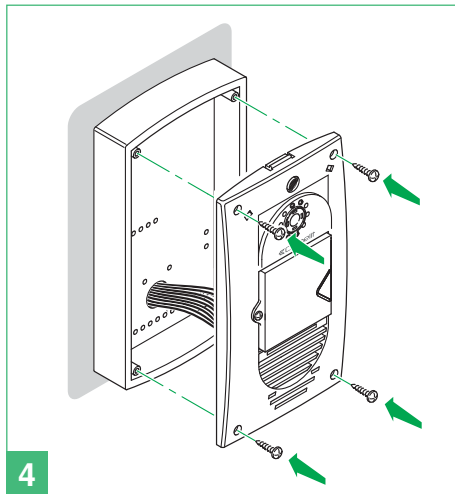
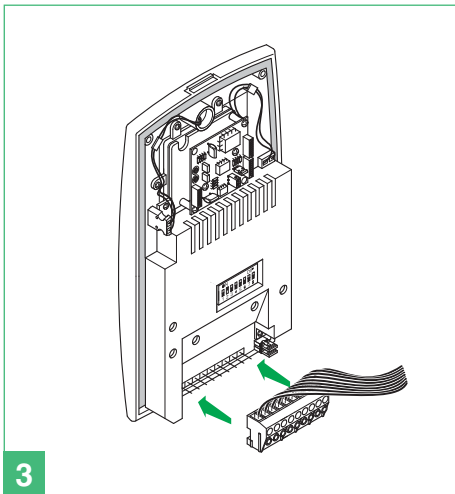
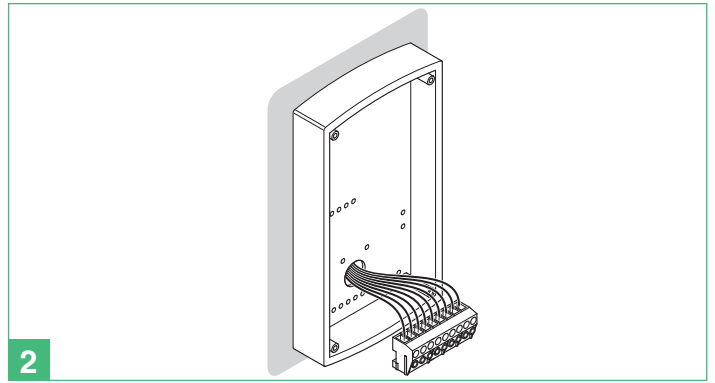
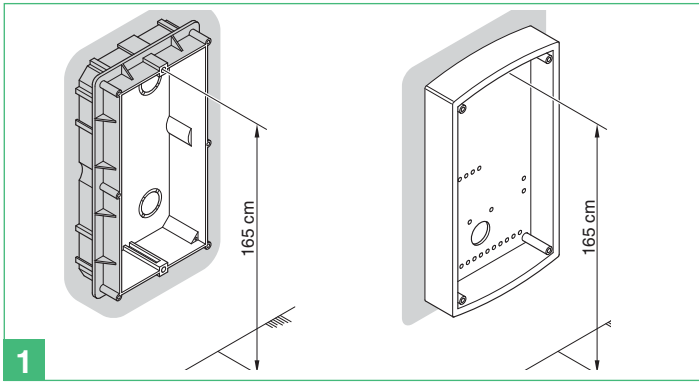

afb. 4 - OPMERKING Alvorens de 4 schroeven vast te zetten, dient u zich ervan te verzekeren of u niet door wilt gaan met de programmering van de speciale functies op pag. 65

afb. 5 - OPMERKING Draai de vier schroeven iets los om de richting van de camera te kunnen wijzigen.

Montage interne aansluiting Magis

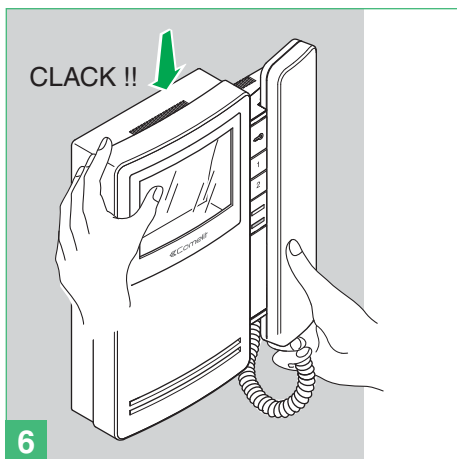
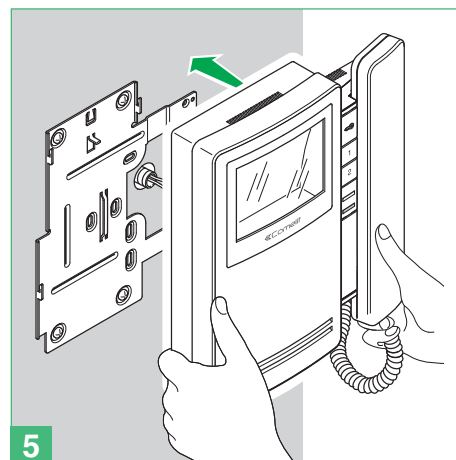
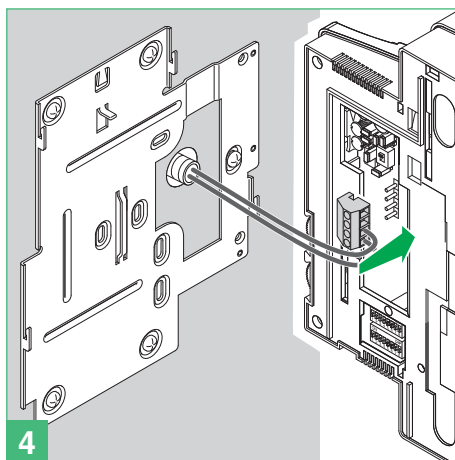
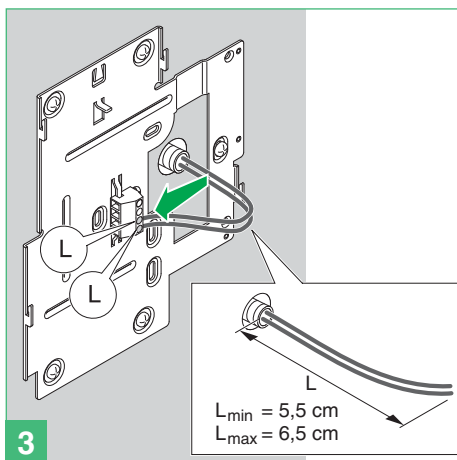
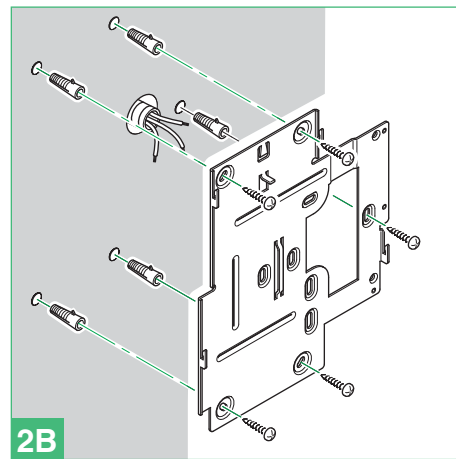
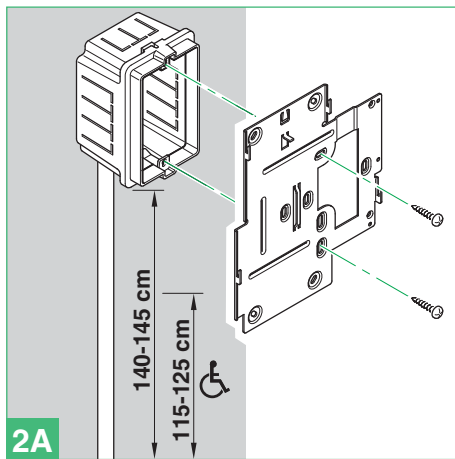
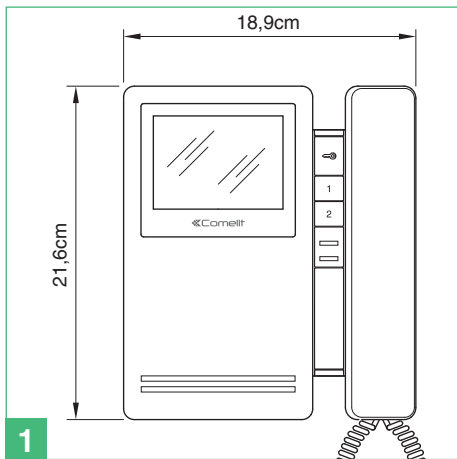

Verwijderen van de monitor

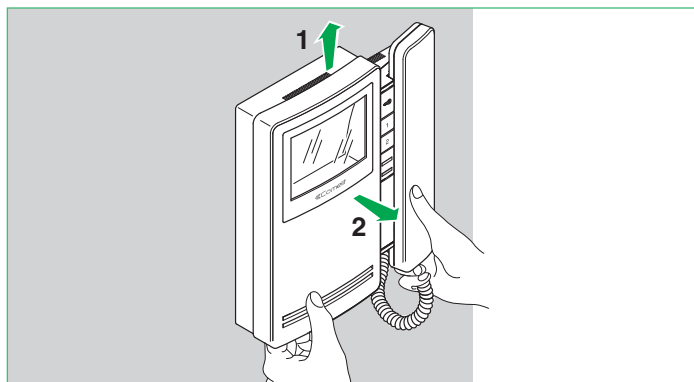

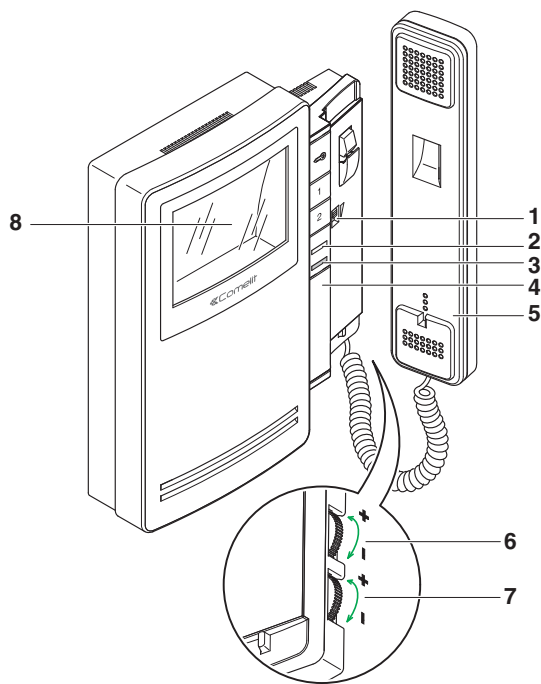

Beschrijving van de monitor:

- 1 Instelling belvolume / schakelaar privacyfunctie (de privacyfunctie schakelt oproepen vanaf het entreepaneel en vanaf deurtelefoons of video-intercommonitors uit; l'attivazione wanneer de privacyfunctie actief is, is een rode indicator naast de schakelaar zichtbaar).
- 2 Signaalled (standaard beschikbaar) voor bezetmelding/artsfunctie aan/deur open.
- 3 Indicatielampje rood - privacy actief.
- 4 Ruimte voor extra knoppen met accessoire Art. 6333, Art. 6434.
- 5 Hoorn van de monitor (de hoorn opnemen om een gesprek te voeren).
- 6 Knop voor instelling van de kleursterkte.
▶ Naar links draaien om de waarde te verhogen.
- 7 Knop voor instelling van de helderheid.
▶ Naar links draaien om de waarde te verhogen.
- 8 Kleurenscherm 3,5".

Beschrijving van de drukknoppen:

- ☞ Deuropener.
- 1 Toets 1 algemene relaissturing (programmeerbaar).
- 2 Toets 2 beeldroep (programmeerbaar).

Beschrijving van de monitor

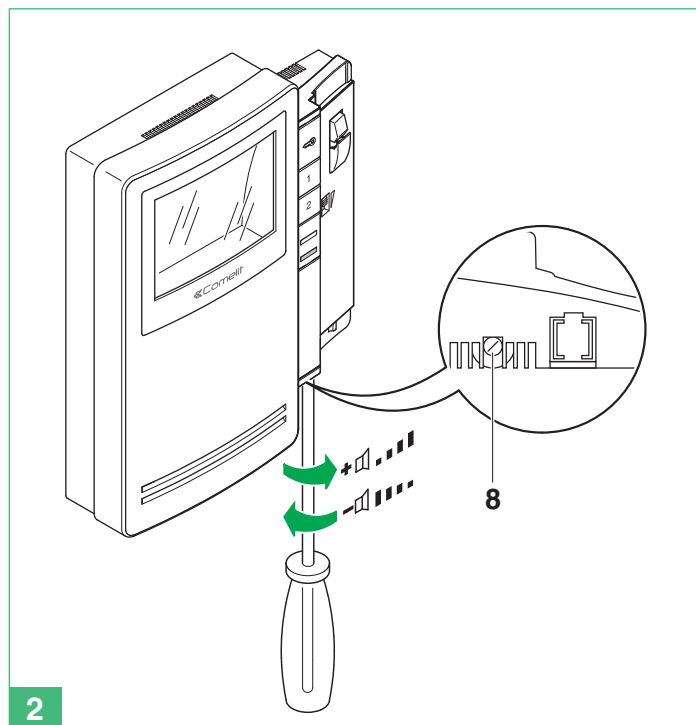
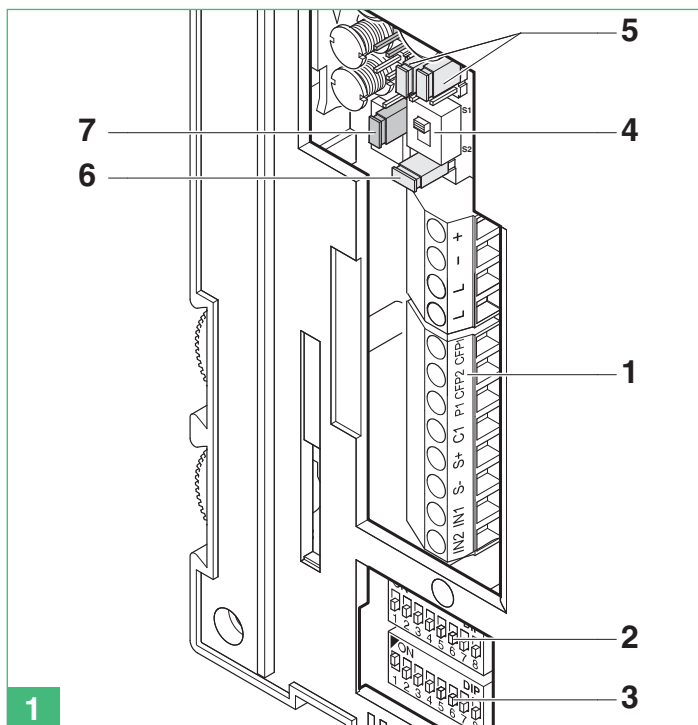

- 1 Aansluitblok voor aansluiting van het systeem:
+ - Klemmen voor voeding.
L L Klemmen voor aansluiting busleiding.
CFP1 CFP2 Ingang voor etagebel.
P1 C1 Klemmen drukknop 1 voor verschillende functies.
Voor een C.NO.-contact (max. 24V-100mA) zet u de jumpers CV3 en CV4 op stand B.
S+ S- Klemmen voor aansluiting van extra bel.
IN1 IN2 Ingang led (programmeerbaar).
- 2 S1 Microschakelaars voor programmering van de gebruikerscode.
- 3 S2 Microschakelaars voor de programmering van drukknoppen en functies (te herkennen aan rode driehoek):
DIP 1-2-3-4 voor de programmering van de functies van de drukknoppen.
DIP 5-6 toegang tot de programmeringen.
DIP 7 voor beheer voedingsspanning (zie schema's en varianten vanaf pag. 114) default = OFF.

- DIP 8:**
ON secundaire grondplaat.
OFF hoofdgrondplaat (default).
- 4 SW3 Keuzeschakelaar voor de modus Simplebus 1 (S1 - default) of Simplebus 2 (S2).
 - 5 CV3 CV4 Jumper voor het vrijmaken van drukknop 1 (C.NO.-contact max. 24V-100mA).
A drukknop 1 algemene relaissturing (standaard) of programmeerbaar.
B drukknop 1 voor diverse functies.
 - 6 CV5 Jumper voor het afsluiten van het videosignaal.
 - 7 CV6 keuzeschakelaar voor gebruik ingang IN 1 (zie pag. 124).
 - 8 Volumeregeling luidspreker (alleen voor geluidsinstelling intercom).

De deurtelefoon kan niet worden gebruikt voor intercomfuncties. De deurtelefoon moet altijd gemonteerd worden met behulp van Art. 1214/2C, zoals afgebeeld in het aansluitschema MSK/FC op pag. 122.

- 1 Indicatielampje voor privacyfunctie.
- 2 Keuzeschakelaar beltoon/privacyfunctie met 3 standen:
Bovenste stand: luide beltoon.
Middelste stand: normale beltoon.
Onderste stand: inschakeling privacyfunctie.
(Met de privacyfunctie wordt bedoeld dat de beltoon van een oproep vanaf het entreepaneel en vanuit de centrale uitgeschakeld wordt. Wanneer de privacyfunctie actief is, brandt er een rood indicatielampje rechtsboven).
- 3 Trimmer voor volumeregeling van microfoon.
- 4 Microschakelaars voor instelling gebruikerscode.
- 5 Aansluitklemmen voor de installatie:
L L Aansluiting op de buslijn.
CFP CFP Ingang voor etagebel.
P1 C1 Klemmen drukknop P1 voor verschillende functies (C. 24V-100mA max) (CV1 en CV2 verwijderen, zie variant SB/X3 op pag. 122).
S+ S- Klemmen voor aansluiting van extra bel.
- 6 CV1 CV2 Jumper, te verwijderen om drukknop P1 C. NO potentiaalvrij te maken.
- 7A/7B JP1 Jumper voor het selecteren van de functie Bellen naar portierscentrale (stand C) / Algemene relaissturing (stand A) van de drukknop P1.

Beschrijving van de drukknoppen:

- Knop deuropener.
- P1 Drukknop P1 bellen naar portierscentrale/algemene relaissturing/ drukknop voor verschillende doeleinden aanwezig in aansluitblok (P1 C1).

Reinigen met een met water bevochtigde doek. Vermijd het gebruik van alcohol en andere agressieve producten.

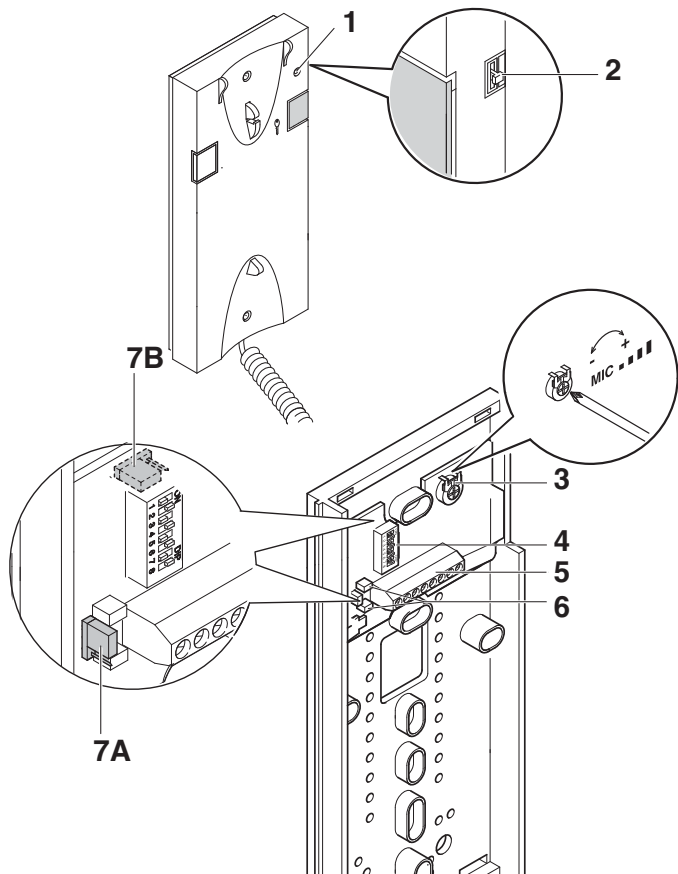

Installatie deurtelefoon Art. 2608

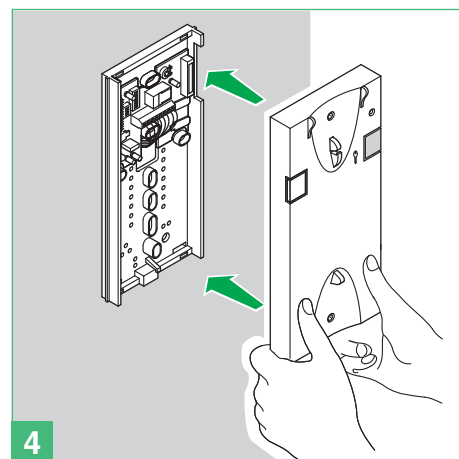
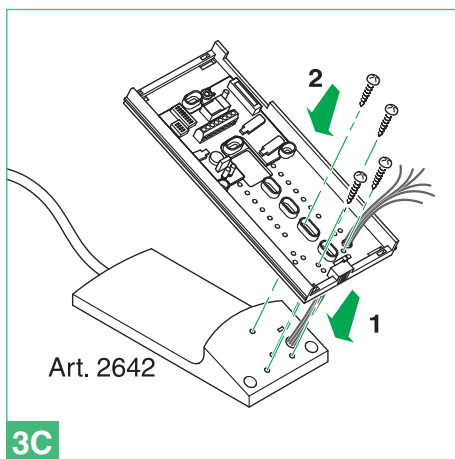
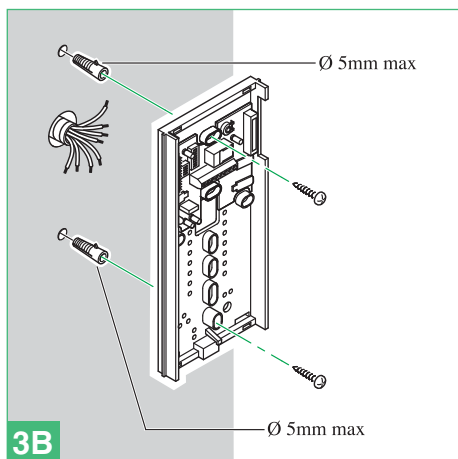
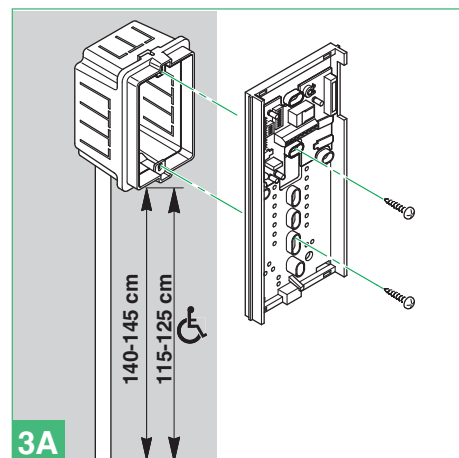
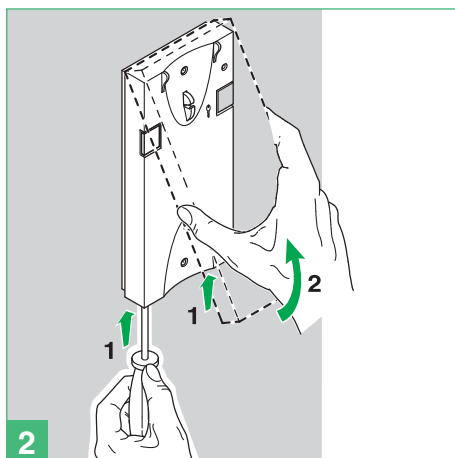
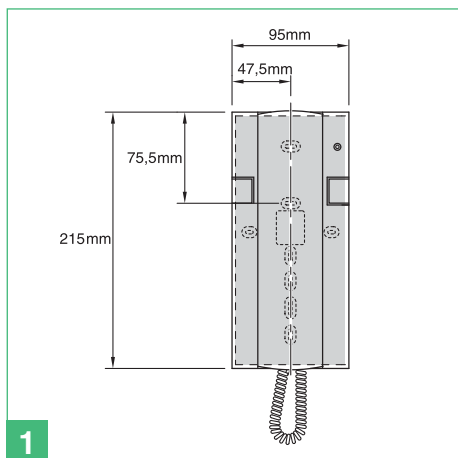

Algemene aanwijzingen voor de installatie en de werking

De maximale totale afstand tussen het entreepaneel en de verst verwijderde monitor is 400 m (met versterker Art. 4833C).
 Het aantal interne aansluitingen met dezelfde gebruikerscode en het aantal extra bellen die op bovenstaande interne aansluitingen zijn aangesloten mogen samen niet meer dan 4 zijn.
 Sluit één extra bel aan per interne aansluiting.
 De MAXIMALE afstand van de verbinding tussen de interne aansluiting en de extra bel bedraagt 20m; gebruik afgeschermd kabel voor deze verbinding en leid de kabels niet in de nabijheid van hoge inductieve belastingen of voedingskabels (230V / 400V).

Tabel afstanden

		A/G MAX	B/E MAX	C MAX	D MAX	F MAX	Art. 1216
Comelit Art. 4577 1 mm ² (Ø 1,2 mm AWG 17)		50 m (165 feet)	50 m (165 feet)	200 m (655 feet)	100 m (330 feet)	150 m (495 feet)	
Comelit Art. 4576-4578	0,5 mm ² (Ø 0,8 mm AWG 20) bus		25 m (85 feet)	200 m (655 feet)	100 m (330 feet)	150 m (495 feet)	
	1,5 mm ² (Ø 1,4 mm AWG 15) power	75 m (245 feet)	100 m (330 feet)				
UTP5 cat. 5 0,2 mm ² (Ø 0,5 mm AWG 24)				190 m (625feet)	60 m (195 feet)	150 m (495 feet)	
0,28 mm ² (Ø 0,6 mm AWG 23)		5 m (15 feet)		190 m (625 feet)	60 m (195 feet)	150 m (495 feet)	
0,5 mm ² (Ø 0,8 mm AWG 20)		25 m (85 feet)	25 m (85 feet)	190 m (625 feet)	60 m (195 feet)	150 m (495 feet)	
1 mm ² (Ø 1,2 mm AWG 17)		50 m (165 feet)	50 m (165 feet)	190 m (625 feet)	60 m (195 feet)	150 m (495 feet)	
1 mm ² (Ø 1,2 mm AWG 17)		50 m (165 feet)	50 m (165 feet)	120 m (395 feet)	40 m (130 feet)	100 m (330 feet)	
1,5 mm ² (Ø 1,4 mm AWG 15)		75 m (245 feet)	100 m (330 feet)	190 m (625 feet)	60 m (195 feet)	150 m (495 feet)	
2,5 mm ² (Ø 1,8 mm AWG 13)		100 m (330 feet)	150 m (495 feet)	190 m (625 feet)	60 m (195 feet)	150 m (495 feet)	

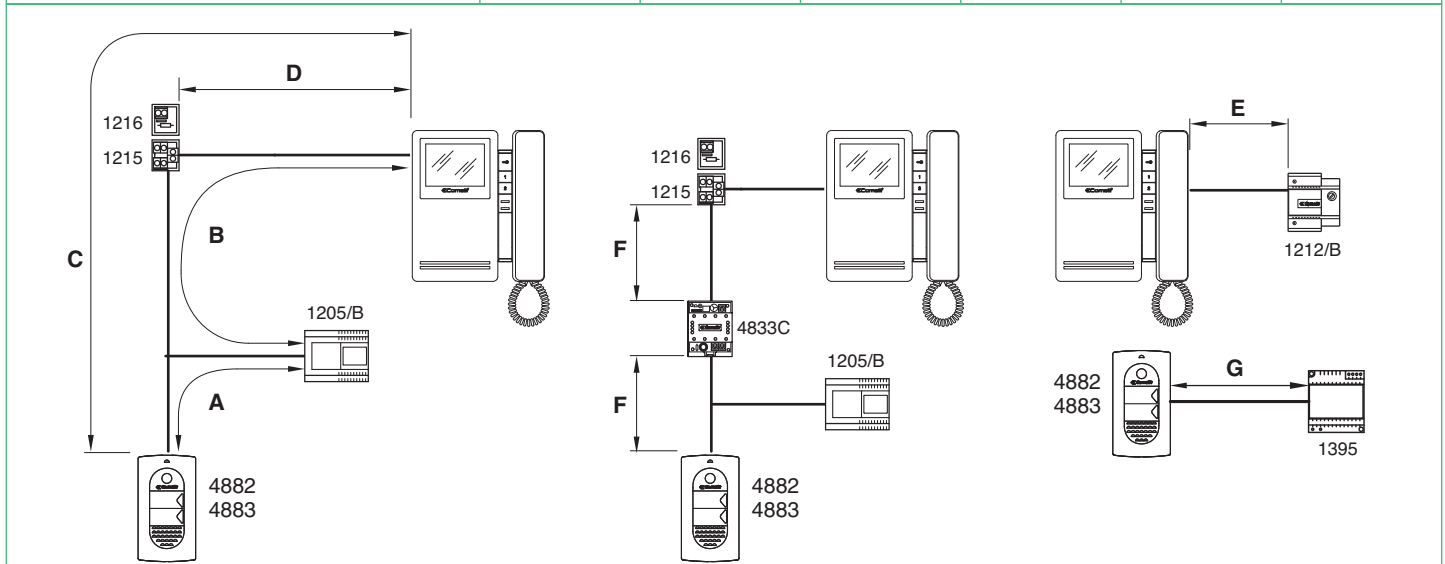

Werking



In geval van voortdurende kortsluiting op de buslijn klinkt bij het entreepaneel een intermitterende waarschuwingston.

Als de bezoeker op de oproep-toets drukt, gaan de witte leds voor de verlichting van de persoon branden, gaat de interne beltoon over (als de privacyfunctie niet is ingeschakeld) en verschijnt het beeld op de hoofdmonitor(en) gedurende circa 60".

De maximale tijdsduur van het gesprek tussen entreepaneel en interne aansluiting bedraagt 90".

Wanneer bij systemen met 2 of meerdere ingangen bij het entreepaneel na de oproep een bezettoon klinkt in plaats van de herhaling van de beltoon, betekent dit dat er al een andere spraakverbinding naar een ander entreepaneel bezig is.

Zie pagina 57 voor het programmeren van andere gebruikersadressen dan die welke zijn ingesteld in de fabriek (1 en 2).

Zie pagina 59 voor de intercomfuncties van het Magis Kit-systeem.

Beschrijving van de instellingen en werking van de knoppen

Instellingen monitor Art. 6402E en Style-intercom

Stand van de microschakelaars van de monitor Art. 6402E

► Zet bij de deurtelefoons Art. 2608, Art. 2610 en Art. 2628 de dipswitches **S1-6, S1-7, S1-8** op **OFF**.

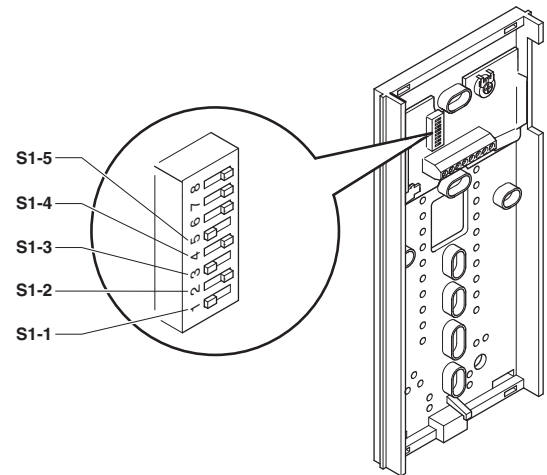
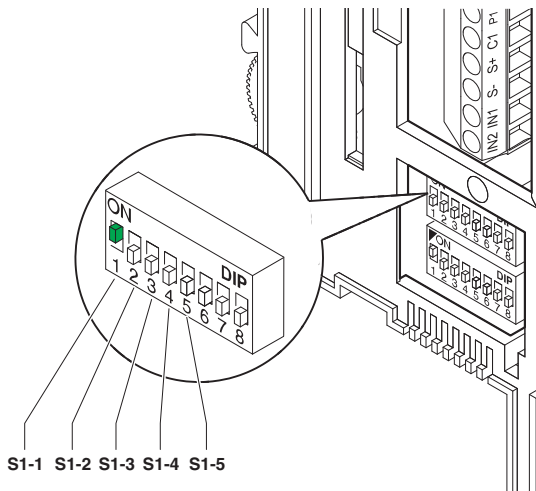

De waarden van **S1-1, S1-2, S1-3, S1-4** en **S1-5** bepalen het **oproepadres** van de monitor en van de intercoms zoals weergegeven is in de volgende tabel.

TAB. A Adressen van de stamleiding

Code	S1
1	

Beschrijving van de functies

☞ **Deuropener:** Door op de knop Deuropener te drukken, wordt het slot dat is aangesloten op het entreepaneel geactiveerd.

Relais " Door op de in de modus Relaissturing ingestelde knop te drukken kan het relais Art 1256 bekrachtigd worden, bijvoorbeeld voor het openen van hekken of garagedeuren of om de beeldwisselaar, Art. 1259C, te activeren.

Vrije knop: De aanduiding Vrije knop geeft aan dat de knop als C.NO.-contact in het aansluitblok kan worden gebruikt, door de juiste instellingen te maken, zie de variant SB2/AAM2 op pagina 125.

Beeldoproep/passieve beeldoproep

- ✓ Deze functie kan ook worden gedeactiveerd.
- ✓ De beeldoproepfunctie is alleen mogelijk als het systeem in de ruststand staat.
- ✓ De functie Beeldoproep wordt alleen aanbevolen voor systemen met 1 of 2 ingangen.

Door op de in deze modus ingestelde knop 2 te drukken, kan op het scherm het beeld dat afkomstig is van het entreepaneel worden weergegeven, ook als er geen oproep heeft plaatsgevonden.

Bij installaties met 2 entreepanelen kan afwisselend het beeld van het ene of het andere entreepaneel weergegeven worden (functie "wisselen") door telkens op de knop 2 te drukken.

Bij secundaire monitors (dipswitch 8 van S2 op ON) heeft de knop 2 tevens de functie van beeldoproep, hiermee kan een monitor worden ingeschakeld na een oproep vanaf het entreepaneel.

Inschakeling:

- druk op de knop voor beeldoproep van de monitor gedurende langer dan 4 sec.

» bevestigingsbeltoon.

Uitschakeling:

- druk op de knop voor beeldoproep van de monitor gedurende langer dan 4 sec.

» 4 bevestigingstonen

Inschakeling:

- De monitor wordt ingeschakeld door op de betreffende knop te drukken (knop 2 - bij gehandhaafde fabrieksinstellingen) en deze meteen weer los te laten.

Inkomende oproep

Door op de in deze modus ingestelde knop te drukken, kan de portierscentrale van het systeem worden opgeroepen.

Intercomoproep eengezinswoning

Met deze functie kunnen andere apparaten (video-intercoms en/of deurtelefoons) die ingesteld zijn op hetzelfde oproepadres worden opgeroepen.

- Door de hoorn van het toestel te nemen, kan de gebelde persoon communiceren met de beller. De verbinding wordt verbroken door de hoorn weer op het toestel te plaatsen.

Een intercomoproep heeft geen voorrang boven een gesprek met/oproep naar het entreepaneel.

In dat geval zal tijdens een poging om een intercomoproep te doen, de led gedurende enkele seconden knipperen om aan te geven dat het systeem bezet is.

Oproep vanaf het entreepaneel

Een oproep vanaf het entreepaneel heeft echter altijd voorrang boven een intercomogesprek. (Het inschakelen van de communicatie met het entreepaneel onderbreekt het eerder aan de gang zijnde intercomogesprek). De gebruikers die reeds met elkaar in gesprek zijn, horen in de hoorn een toon die gelijk is aan een oproeptoon als de oproep voor hen bestemd is, of anders een drietonige waarschuwing.

- Om de oproep van het entreepaneel te beantwoorden, moet de hoorn van een vrij apparaat worden opgenomen, of moet de hoorn van een apparaat waarop een intercomogesprek gaande is worden opgehangen en weer opgenomen.

Artsfunctie

Met deze functie kan de deuropener automatisch in werking gesteld worden bij een oproep vanaf het entreepaneel naar het adres van de interne aansluiting waarop deze functie geactiveerd is.

Inschakeling / uitschakeling:

- houd de knop die voor deze functie is ingesteld gedurende 2 sec. ingedrukt.

» als de functie actief is, blijft de signaalled aan.

Extra hoofd- of secundaire monitors

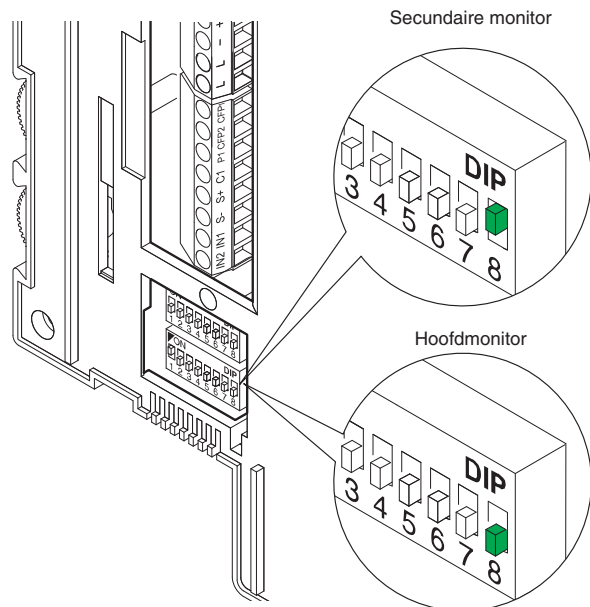

De instelling van dipswitch 8 van S2 bepaalt of de grondplaat in kwestie zal worden beheerd als hoofdgrondplaat (P) of secundaire grondplaat (S). Het entreepaneel kan maximaal 4 video-intercoms of deurtelefoons per oproepstoets beheren.

In de traditionele configuratie van de Magis Kit kunnen maximaal 2 hoofd-video-intercoms en 2 secundaire video-intercoms per oproepstoets bestaan die allemaal worden gevoed door hetzelfde **Art. 1205/B**.

Binnen één gezinseenheid kunnen maximaal 3 hoofd-video-intercoms worden beheerd (d.w.z. ingesteld op dezelfde gebruikerscode). In deze specifieke configuratie moet ieder van de extra hoofd-video-intercoms worden gevoed door het speciale **Art. 1212/B** (zie variant MSK/HCA, MSK/IC pag. 118, 119).

Als er een oproep plaatsvindt vanaf het entreepaneel, zal het systeem de monitor van de hoofd-video-intercom inschakelen.

Eventuele secundaire monitors van dezelfde gezinseenheid blijven uit.

Als een oproep van het entreepaneel door een secundaire video-intercom wordt beantwoordt, wordt het beeld automatisch op de monitor weergegeven.

De monitor van de hoofd-video-intercom gaat dan uit en het beeld wordt weergegeven op de monitor van de video-intercom waarvan de knop 2 beeldoproep/passieve beeldoproep is ingedrukt.

Om het beeld weer te geven zonder het geluid met het entreepaneel in te schakelen, drukt u op de knop 2- beeldoproep/passieve beeldoproep.

Standaardconfiguratie

DIP S2								met Art. 6433, 6434			
DIP 1	DIP 2	DIP 3	DIP 4	P1	P2	🔑	☎️	P3	P4	P5	P6
0	0	0	0	CCS	AI			ACT	D	PAN	K
1	0	0	0	ACT	AI			INT	INTb	D	CCS
0	1	0	0	INT	AI			INTb	ACT	CCS	CCP
1	1	0	0	ACT	CCS			CCP	PAN	K	D
0	0	1	0	ACT	ACT	ACT		ACT	ACT	ACT	ACT
1	0	1	0	INT	ACT			CCS	CCP	INTb	PAN
0	1	1	0	AI	D			K	CCS	CCP	INTb
1	1	1	0	INTb	INT			AI	INT	PAN	D
0	0	0	1	CCS	PAN			D	AI	INT	INTb
1	0	0	1	K	CCS			PAN	CCP	AI	INT
0	1	0	1	CCP	K			PAN	ACT	INT	AI
1	1	0	1	PAN	CCP			CCS	K	ACT	D
0	0	1	1	D	INTb			INT	ACT	AI	CCS
1	0	1	1	INT	INT			INT	INT	INT	INT
0	1	1	1	NULL	NULL	NULL	NULL	NULL	NULL	NULL	NULL
1	1	1	1					PROG			

🔑	Deuropener	CCS	Bellen naar portierscentrale	INTb	Intercomsysteem tweegezinswoning - alleen voor KIT
☎️	Audioverbinding	K	Oproep deurtelefoon bewaker	NULL	Geen functie
ACT	Relais	D	Arts	PROG	Geprogrammeerde functies, zie pag. 58-59-60-61 Bij deze instelling van de dip beheren de drukknoppen de geprogrammeerde functies; De NIET-geprogrammeerde drukknoppen bedienen de functies vermeld op regel 0000
AI	Beeldoproep	PAN	Paniek		
CCP	Bellen naar hoofcentrale	INT	Programmeerbaar intercomsysteem, algemeen of selectief - standaard oproep eengezinswoning voor KIT en Simplebus Top		



Algemene waarschuwingen voor de programmering van de drukknoppen

Indien de standaardconfiguratie (zie tabel pag. 58) niet voldoet aan de vereisten, kunnen de drukknoppen anders worden geprogrammeerd volgens de hieronder beschreven procedure.

Aan het eind plaatst u de dipswitches 1-2-3-4 van S2 op 1111 (setting PROG in de configuratietabellen pag. 58-59-60-61). Met deze instelling van

de dipswitches bedienen de drukknoppen de geprogrammeerde functies, de NIET-geprogrammeerde drukknoppen bedienen de functies vermeld op regel 0000 (zie tabel pag. 58). Stel de instelling van de gebruikerscode opnieuw in op S1, zie tabel A op pag. 57.

Programmering drukknoppen voor algemene of geadresseerde relaissturing

DIP S2				met Art. 6433, 6434								DIP S1	
DIP 1	DIP 2	DIP 3	DIP 4	P1	P2			P3	P4	P5	P6	ADRES ON 1 2 3 4 5 6 7 8	
0	0	0	0					ACT					
1	0	0	0	ACT									
0	1	0	0						ACT				
1	1	0	0	ACT									
0	0	1	0	ACT	ACT	ACT		ACT	ACT	ACT	ACT		
1	0	1	0		ACT								
0	1	1	0										
1	1	1	0										
0	0	0	1										
1	0	0	1										
0	1	0	1						ACT				
1	1	0	1							ACT			
0	0	1	1										
1	0	1	1										
0	1	1	1										
1	1	1	1										
PROG													

Voorbeeld:

op monitor met gebruikerscode 5 is programmering P1 = algemene relaissturing, P2 = geadresseerde relaissturing met code 125.

1. Plaats dipswitches 5-6 van S2 in de combinatie 01.

» de led (groen) knippert.

2. Raadpleeg de tabel op pag. 59 en kies een combinatie waarin de relaisfunctie (ACT) verschijnt voor de drukknoppen die u wenst te programmeren.

Voorbeeld: voor P1 = algemene relaissturing stelt u de dipswitches 1-2-3-4 van S2 in op de combinatie 1000 of 1100 of 0010 (P1=ACT), en stelt u de dipswitch van S1 in op de combinatie 11111111, ga door naar punt 3.

Voorbeeld: voor P2 = relaissturing geadresseerd op code 125 stelt u de dipswitches 1-2-3-4 van S2 in op de combinatie 0010 of 1010 (P2=ACT),

en stelt u S1 in met adres 125 volgens **tabel C** op pag. 61, ga door naar punt 3.

3. Duw op de drukknop waaraan u de functie wil toewijzen en laat weer los.

» de led (groen) gaat aan.

» bevestigingstoon in de hoorn.

4. Om de programmering te verlaten stelt u dipswitches 5-6 van S2 in op de combinatie 00.

» de led (groen) gaat uit.

5. Aan het eind van de programmering stelt u de dipswitches 1-2-3-4 van S2 in op de combinatie 1111. Stel de instelling van de gebruikerscode opnieuw in op S1, zie tabel A op pag. 57.

Programmeringen voor intercomoproep



De algemene en selectieve intercom zijn **NIET** compatibel op dezelfde stamleiding.

Programmeren/wissen van een intercomadres (enkel voor selectieve intercom)

1)	2)						3)	
S1	DIP 1	DIP 2	DIP 3	DIP 4	DIP 5	DIP 6	S2	
Programmering: code invoeren, TAB. B op pag. 59	0	0	0	1	1	1	 	
Wissen	1	1	1	1	1	1	 	



Noteer de instelling van S2, S1 en herstel deze aan het einde van de programmering.

TAB. B Adressen voor selectieve intercom

Code	Dip switch ON	S1	Code	Dip switch ON	S1	Code	Dip switch ON	S1
1	1		4	4		7	7	
2	2		5	5		8	8	
3	3		6	6				

Het intercomadres moet bij alle binnentoestellen van de stamleiding worden ingesteld.

Het is mogelijk om hetzelfde intercomadres aan max. 3 binnentoestellen te koppelen.

Voor de groepsoproep moeten de gewenste intercomcodes tegelijkertijd worden geselecteerd (max. 3).

Programmeringen drukknoppen voor intercomoproep

DIP S2								met Art. 6433, 6434				DIP S1	
DIP 1	DIP 2	DIP 3	DIP 4	P1	P2			P3	P4	P5	P6	ADRES ON 1 2 3 4 5 6 7 8	
0	0	0	0										
1	0	0	0					INT	INTb				
0	1	0	0	INT				INTb					
1	1	0	0										
0	0	1	0										
1	0	1	0	INT						INTb			
0	1	1	0								INTb		
1	1	1	0	INTb	INT				INT				
0	0	0	1							INT	INTb		
1	0	0	1								INT		
0	1	0	1							INT			
1	1	0	1										
0	0	1	1		INTb			INT					
1	0	1	1	INT	INT			INT	INT	INT	INT		
0	1	1	1										
1	1	1	1										

Voorbeeld 1 - Selectieve intercom

op monitor met gebruikerscode 1 en intercomadres 1 is programmering P3 = selectieve intercom op adres 2, P4 = selectieve intercom op adres 3.

Voorbeeld 2 - Intercom KIT (intercom tussen 2 aangrenzende adressen binnen de range van 1 tot 30, waarvan het eerste oneven is):

op monitor met gebruikerscode 1 is programmering P3 = interne algemene oproep, P4 = intercomsysteem tweegezinwoning op adres 2.

1. Stel de dipswitches 5-6 van S2 in op de combinatie 01.
» *de led (groen) knippert.*
2. Raadpleeg de tabel op pag. 60 en kies een combinatie waarin de intercomfunctie (INT of INTb) verschijnt voor de drukknoppen die u wenst te programmeren.

Voorbeeld 1: voor P3 = selectieve intercom stelt u de dipswitches 1-2-3-4 van S2 in op de combinatie 1000 of 0011 of 1011 (P3=INT), en stelt u S1 in met adres 2 volgens **tabel B** op pag. 59, ga naar punt 3.

Voorbeeld 1: voor P4 = selectieve intercom stelt u de dipswitches 1-2-3-4 van

S2 in op de combinatie 1110 of 1011 (P4=INT), en stelt u S1 in met adres 3 volgens **tabel B** op pag. 59, ga naar punt 3.

Voorbeeld 2: voor P3 = interne algemene oproep en P4 = intercomsysteem tweegezinwoning stelt u de dipswitches 1-2-3-4 van S2 in op de combinatie 1000 (P3=INT, P4=INTb), en stelt u S1 in met gebruikerscode 1 volgens **tabel A** op pag. 57, ga naar punt 3.

3. Duw op de drukknop waaraan u de functie wil toewijzen en laat weer los
» *de led (groen) gaat aan.*
» *bevestigingstoon in de hoorn.*
4. Om de programmering te verlaten stelt u dipswitches 5-6 van S2 in op combinatie 00.
» *de led (groen) gaat uit.*
5. **Aan het eind van de programmering stelt u de dipswitches 1-2-3-4 van S2 in op de combinatie 1111. Stel de instelling van de gebruikerscode opnieuw in op S1, zie tabel A op pag. 57.**

Programmering drukknoppen voor andere functies

DIP S2								met Art. 6433, 6434			
DIP 1	DIP 2	DIP 3	DIP 4	P1	P2			P3	P4	P5	P6
0	0	0	0	CCS	AI				D	PAN	K
1	0	0	0		AI					D	CCS
0	1	0	0		AI					CCS	CCP
1	1	0	0		CCS			CCP	PAN	K	D
0	0	1	0								
1	0	1	0					CCS	CCP		PAN
0	1	1	0	AI	D			K	CCS	CCP	PAN
1	1	1	0					AI		PAN	D
0	0	0	1	CCS	PAN			D	AI		
1	0	0	1	K	CCS			PAN	CCP	AI	
0	1	0	1	CCP	K			PAN			AI
1	1	0	1	PAN	CCP			CCS	K		D
0	0	1	1	D						AI	CCS
1	0	1	1								
0	1	1	1	NULL	NULL	NULL	NULL	NULL	NULL	NULL	NULL
1	1	1	1								

Legenda

	Deuropener	CCS	Bellen naar portierscentrale	NULL	Geen functie
	Audioverbinding	K	Oproep deurtelefoon bewaker	PROG	Geprogrammeerde functies
AI	Beeldoproep	D	Arts		
CCP	Bellen naar hoofcentrale	PAN	Paniek		

Voorbeeld:

op de monitor met gebruikerscode 5 is programmering P5 = beeldoproep, P6 = bellen naar intercomcentrale.

1. Stel de dipswitches 5-6 van S2 in op de combinatie 01.
» *de led (groen) knippert.*
2. Raadpleeg de tabel op pag. 60 en kies een combinatie waarin de gewenste/nodige functies verschijnen voor de drukknoppen die u wenst te programmeren.

Voorbeeld: voor P5 = beeldoproep en P6 = bellen naar intercomcentrale, stelt u de dipswitches 1-2-3-4 van S2 in op de combinatie 0011 (P5=AI, P6=CCS).

3. Duw de drukknop waaraan u de functie wil toewijzen en laat weer los.
» *de led (groen) gaat aan.*
» *bevestigingstoon in de hoorn.*
4. Om de programmering te verlaten stelt u dipswitches 5-6 van S2 in op de combinatie 00.
» *de led (groen) gaat uit.*
5. **Aan het eind van de programmering stelt u de dipswitches 1-2-3-4 van S2 in op de combinatie 1111.**







TAB. C Adressen van de stamleiding

Code	Dip switch ON	Code	Dip switch ON	Code	Dip switch ON	Code	Dip switch ON	Code	Dip switch ON	Code	Dip switch ON	Code	Dip switch ON	Code	Dip switch ON
1	1	31	1,2,3,4,5	61	1,3,4,5,6	91	1,2,4,5,7	121	1,4,5,6,7	151	1,2,3,5,8	181	1,3,5,6,8	211	1,2,5,7,8
2	2	32	6	62	2,3,4,5,6	92	3,4,5,7	122	2,4,5,6,7	152	4,5,8	182	2,3,5,6,8	212	3,5,7,8
3	1,2	33	1,6	63	1,2,3,4,5,6	93	1,3,4,5,7	123	1,2,4,5,6,7	153	1,4,5,8	183	1,2,3,5,6,8	213	1,3,5,7,8
4	3	34	2,6	64	7	94	2,3,4,5,7	124	3,4,5,6,7	154	2,4,5,8	184	4,5,6,8	214	2,3,5,7,8
5	1,3	35	1,2,6	65	1,7	95	1,2,3,4,5,7	125	1,3,4,5,6,7	155	1,2,4,5,8	185	1,4,5,6,8	215	1,2,3,5,7,8
6	2,3	36	3,6	66	2,7	96	6,7	126	2,3,4,5,6,7	156	3,4,5,8	186	2,4,5,6,8	216	4,5,7,8
7	1,2,3	37	1,3,6	67	1,2,7	97	1,6,7	127	1,2,3,4,5,6,7	157	1,3,4,5,8	187	1,2,4,5,6,8	217	1,4,5,7,8
8	4	38	2,3,6	68	3,7	98	2,6,7	128	8	158	2,3,4,5,8	188	3,4,5,6,8	218	2,4,5,7,8
9	1,4	39	1,2,3,6	69	1,3,7	99	1,2,6,7	129	1,8	159	1,2,3,4,5,8	189	1,3,4,5,6,8	219	1,2,4,5,7,8
10	2,4	40	4,6	70	2,3,7	100	3,6,7	130	2,8	160	6,8	190	2,3,4,5,6,8	220	3,4,5,7,8
11	1,2,4	41	1,4,6	71	1,2,3,7	101	1,3,6,7	131	1,2,8	161	1,6,8	191	1,2,3,4,5,6,8	221	1,3,4,5,7,8
12	3,4	42	2,4,6	72	4,7	102	2,3,6,7	132	3,8	162	2,6,8	192	7,8	222	2,3,4,5,7,8
13	1,3,4	43	1,2,4,6	73	1,4,7	103	1,2,3,6,7	133	1,3,8	163	1,2,6,8	193	1,7,8	223	1,2,3,4,5,7,8
14	2,3,4	44	3,4,6	74	2,4,7	104	4,6,7	134	2,3,8	164	3,6,8	194	2,7,8	224	6,7,8
15	1,2,3,4	45	1,3,4,6	75	1,2,4,7	105	1,4,6,7	135	1,2,3,8	165	1,3,6,8	195	1,2,7,8	225	1,6,7,8
16	5	46	2,3,4,6	76	3,4,7	106	2,4,6,7	136	4,8	166	2,3,6,8	196	3,7,8	226	2,6,7,8
17	1,5	47	1,2,3,4,6	77	1,3,4,7	107	1,2,4,6,7	137	1,4,8	167	1,2,3,6,8	197	1,3,7,8	227	1,2,6,7,8
18	2,5	48	5,6	78	2,3,4,7	108	3,4,6,7	138	2,4,8	168	4,6,8	198	2,3,7,8	228	3,6,7,8
19	1,2,5	49	1,5,6	79	1,2,3,4,7	109	1,3,4,6,7	139	1,2,4,8	169	1,4,6,8	199	1,2,3,7,8	229	1,3,6,7,8
20	3,5	50	2,5,6	80	5,7	110	2,3,4,6,7	140	3,4,8	170	2,4,6,8	200	4,7,8	230	2,3,6,7,8
21	1,3,5	51	1,2,5,6	81	1,5,7	111	1,2,3,4,6,7	141	1,3,4,8	171	1,2,4,6,8	201	1,4,7,8	231	1,2,3,6,7,8
22	2,3,5	52	3,5,6	82	2,5,7	112	5,6,7	142	2,3,4,8	172	3,4,6,8	202	2,4,7,8	232	4,6,7,8
23	1,2,3,5	53	1,3,5,6	83	1,2,5,7	113	1,5,6,7	143	1,2,3,4,8	173	1,3,4,6,8	203	1,2,4,7,8	233	1,4,6,7,8
24	4,5	54	2,3,5,6	84	3,5,7	114	2,5,6,7	144	5,8	174	2,3,4,6,8	204	3,4,7,8	234	2,4,6,7,8
25	1,4,5	55	1,2,3,5,6	85	1,3,5,7	115	1,2,5,6,7	145	1,5,8	175	1,2,3,4,6,8	205	1,3,4,7,8	235	1,2,4,6,7,8
26	2,4,5	56	4,5,6	86	2,3,5,7	116	3,5,6,7	146	2,5,8	176	5,6,8	206	2,3,4,7,8	236	3,4,6,7,8
27	1,2,4,5	57	1,4,5,6	87	1,2,3,5,7	117	1,3,5,6,7	147	1,2,5,8	177	1,5,6,8	207	1,2,3,4,7,8	237	1,3,4,6,7,8
28	3,4,5	58	2,4,5,6	88	4,5,7	118	2,3,5,6,7	148	3,5,8	178	2,5,6,8	208	5,7,8	238	2,3,4,6,7,8
29	1,3,4,5	59	1,2,4,5,6	89	1,4,5,7	119	1,2,3,5,6,7	149	1,3,5,8	179	1,2,5,6,8	209	1,5,7,8	239	1,2,3,4,6,7,8
30	2,3,4,5	60	3,4,5,6	90	2,4,5,7	120	4,5,6,7	150	2,3,5,8	180	3,5,6,8	210	2,5,7,8	*240	5,6,7,8

*OPMERKING: de code 240 is gereserveerd voor de portierscentrale

Reset van de programmering

! 1)	! 2)						3)	4)
S1	DIP 1	DIP 2	DIP 3	DIP 4	DIP 5	DIP 6	S2	S1/S2/LED1
<p>DIP ON</p>	1	1	1	1	1	1	<p>5 sec</p>	<p>2 sec</p>
<p>Fabrieksinstellingen:</p> <ul style="list-style-type: none"> • Functies drukknoppen afhankelijk van de combinatie van DIP 1-2-3-4 van S2; • Intercomadres niet voorzien; • Functie range en min. en max. adressen niet voorzien; • Reset beltonen; • Ingang IN 1 => LED (default). 								<p>Noteer de instelling van S2, S1 en herstel deze aan het einde van de programmering.</p>

Voer de werkzaamheden van 1 tot 4 uit													
Programming range/beltonen	! 1)		! 2)						3)		4)		
	S1	S2	DIP 1	DIP 2	DIP 3	DIP 4	DIP 5	DIP 6	S1/S2/LED1				
Range minimaal adres												 <p>Noteer de instelling van S2, S1 en herstel deze aan het einde van de programmering</p>	
Range maximaal adres	code instellen, TAB. C op pag. 61		0	0	0	0	1	0			 		
Activering range													
Desactivering range													
Keuze van de polyfone beltoon			0	1	0	1	1	0					
Keuze van de klassieke beltoon (default)													

Voer de werkzaamheden van 1 tot 4 uit										
		! 1)				! 2)			3)	4)
Programmering ingang IN1 voor signalering led/ alarm/deuropener/relais		S1	DIP 1	DIP 2	DIP 3	DIP 4	DIP 5	DIP 6	S2	S1/S2/LED1
Ingang IN 1 ⇒ LED (default), zie blz. 124			0	0	0	1	1	0		
Ingang IN 1 ⇒ ALARM, zie blz. 124			0	0	0	1	1	0		
Ingang IN 1 ⇒ DEUROPENER, zie blz. 124			0	0	1	0	1	0		
Ingang IN 1 ⇒ GEADRESSEERDE RELAISSTURING, zie blz. 124		code instellen, TAB. C op pag. 61	0	0	1	0	1	0		
Ingang N 1 ⇒ ALGEMENE RELAISSTURING, zie blz. 124			0	0	1	0	1	0		

! Noteer de instelling van S2, S1 en herstel deze aan het einde van de programmering

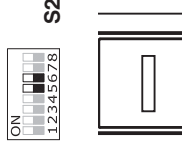
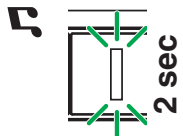

Directe programmering van de intercomoproep

Hiermee kunnen de intercomoproepen rechtstreeks vanop de binnentoestellen worden geprogrammeerd.

✓ Hiervoor zijn 2 operators nodig.

Fase 1: toegang tot programmering

Operator 1 en Operator 2 voeren dezelfde handelingen uit op 2 binnentoestellen:

1. Stel dipswitch 1-2-3-4 van S2 in op de combinatie 1111.

2. Neem de hoorn op.

3. *Houd de knoppen 1 en 2 gedurende 3 sec. ingedrukt.*

» *Er komt 1 toon uit het binnentoestel.*

» *De groene led knippert.*

» *Het binnentoestel gaat in audioverbinding.*

» *Nu kunnen de 2 operators met elkaar communiceren.*

Fase 2: programmering intercomoproep

Operator 1:

▶ Drukt op de knop die hij wil programmeren om operator 2 op te roepen (bv. 2).

» *Er komt een bevestigingston uit het binnentoestel van operator 1.*

Operator 2:

▶ Drukt op de knop die hij wil programmeren om operator 1 op te roepen (bv. 1).

» *Er komt een bevestigingston uit het binnentoestel van operator 2.*

Operator 1/Operator 2:

▶ Hang de hoorn op.

» *Er komt 1 toon uit het binnentoestel.*

» *Zo is de programmering van de 2 binnentoestellen voltooid.*

Om nog een binnentoestel te programmeren moet worden overgegaan naar FASE 3.

Fase 3: programmering van andere binnentoestellen

Operator 1/Operator 2:

1. Als hij op de nieuwe locatie is, voert hij fase 1 uit om de communicatie tot stand te brengen.

2. Herhaal fase 2.

OPMERKING: Indien er een oproep binnenkomt tijdens het programmeren, moet de oproep eerst worden beantwoord. Vervolgens kan de programmeringsfase hervat worden.

Wijzigen van de beltonen van de monitor

1. Houd knop  ingedrukt tot u een bevestigingston hoort (dit is alleen mogelijk wanneer de installatie in de ruststand verkeert; wanneer dit niet het geval is, knippert de led om de gebruiker te waarschuwen).

2. Druk op knop  en laat weer los:

1 maal (er klinkt één enkele bevestigingston) om de beltoon van een oproep vanaf het entreepaneel te wijzigen.

2 maal (er klinken 2 bevestigingstonen) om de beltoon van een oproep vanaf de intercomocentrale te wijzigen.

3 maal (er klinken 3 bevestigingstonen) om de beltoon van een intercomoproep vanaf het binnentoestel te wijzigen.

4 maal (er klinken 4 bevestigingstonen) om de beltoon van een oproep van de etagebel te wijzigen.

Wanneer u nog vaker op de knop  drukt, wordt de bovenstaande volgorde herhaald.

3. Druk op de knop 1 en laat hem weer los om de beschikbare beltonen in volgorde te beluisteren.

4. Druk op de knop 2 om de keuze van de laatst beluisterde beltoon te bevestigen en om de modus Wijzigen oproeptoon van monitor (op ieder gewenst moment) te verlaten. Wanneer u de modus Wijzigen beltoon van monitor verlaat, klinkt er een bevestigingston.

Speciale programmeringsmogelijkheden Art. 4882

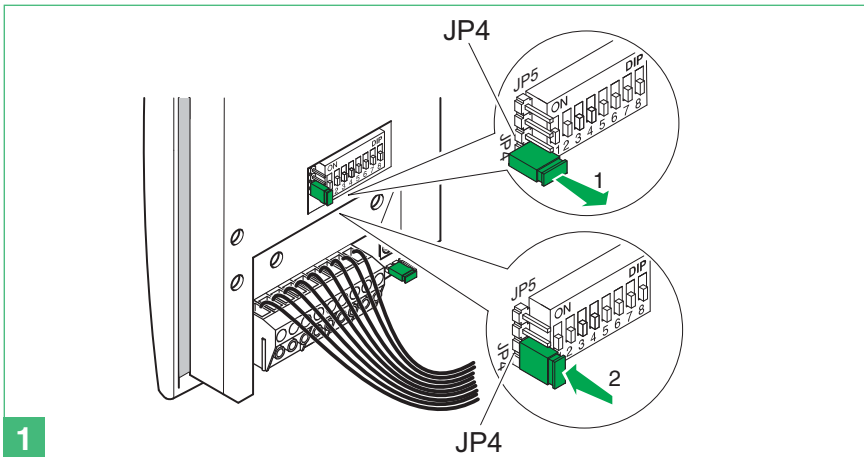

1

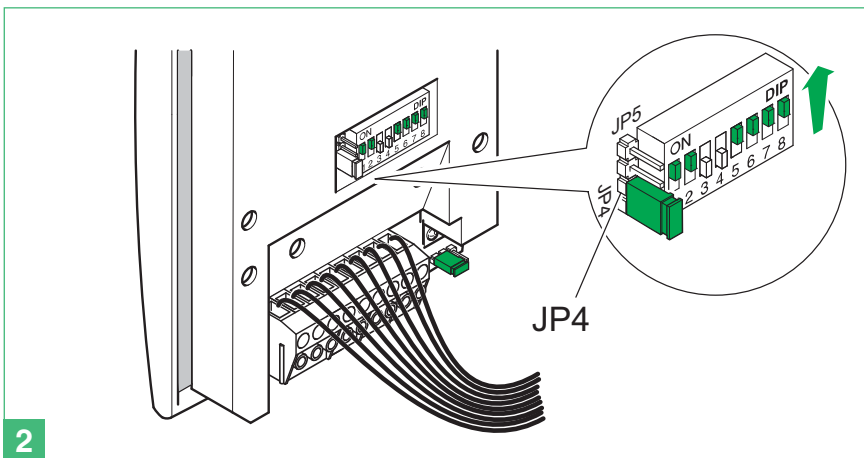

2

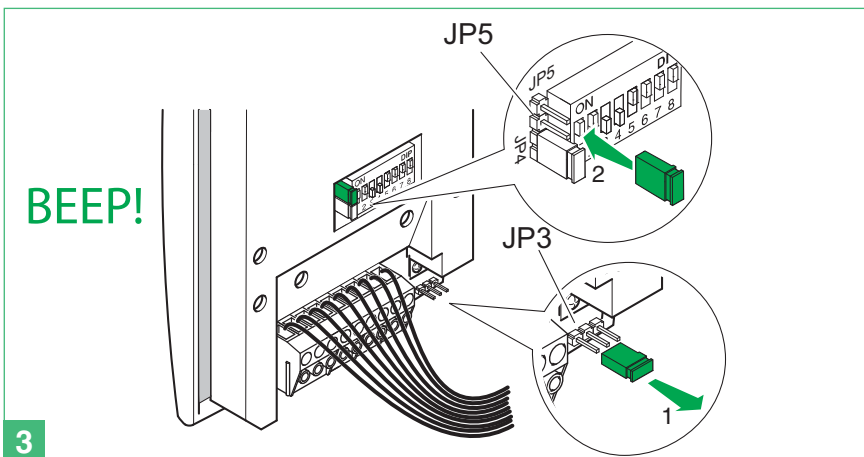

3

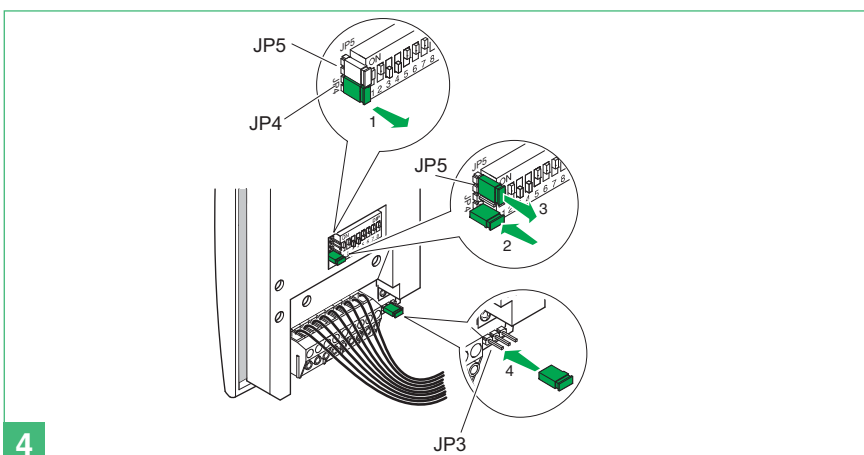

4

Code	Dip switch ON	Slot
245	1,3,5,6,7,8	Tijd slot: 2 sec. + toon uit (default)
246	2,3,5,6,7,8	Bevestigingstoon slot: ingeschakeld
247	1,2,3,5,6,7,8	Tijd slot: 8 sec.
252	3,4,5,6,7,8	Deuropener altijd aan (default)
253	1,3,4,5,6,7,8	Deuropener alleen aan voor de opgeroepen gebruiker

Functies installatie		
243	1,2,5,6,7,8	Wachttijd reset: 10 sec. (default)
244	3,5,6,7,8	Wachttijd reset: 1 sec.
248	4,5,6,7,8	Oproep: enkel (default)
249	1,4,5,6,7,8	Oproep verzenden: drievoudig

Reset default		
254	2,3,4,5,6,7,8	

Art. 4882 bieden een aantal speciale programmeringsmogelijkheden afhankelijk van de verschillende systeemvereisten.

1. Ga naar de programmeermodus door de jumper JP4 (afb. 1) in een verticale stand te zetten.
2. Stel op de dipswitches de code van de functie in die u wilt programmeren (afb. 2) volgens de tabel op pag. 65.
3. Bevestig de ingestelde functie door de jumper JP3 in de stand JP5 (afb. 3) te zetten en wacht tot een bevestigingstoon klinkt.
4. Haal de jumper uit JP5 en herhaal de stappen 2 en 3 van de procedure voor het programmeren van andere parameters.
5. Plaats de jumpers na deze procedure weer in hun oorspronkelijke stand (afb. 4): de jumper JP4 in een horizontale stand en de tweede jumper van JP5 in de stand JP3.

Hinweise

- Der Einbau muss genau nach den Anweisungen des Herstellers und unter Einhaltung der einschlägigen Vorschriften erfolgen.
- Alle Geräte dürfen ausschließlich nur zu dem Zweck eingesetzt werden, für den sie entwickelt worden sind. Die **Comelit Group S.p.A.** übernimmt keine Haftung für einen unsachgemäßen Gebrauch der Geräte, für durch Dritte vorgenommene Änderungen oder die Verwendung von Nicht-Original-Zubehör und -Ersatzteilen.
- Alle unsere Produkte erfüllen die Anforderungen der Richtlinien 2006/95/EG (geändert durch die Richtlinie 73/23/EWG und deren nachfolgende Ergänzungen), wie durch ihre **CE**-Kennzeichnung bestätigt wird.
- Die Kabel der Steigleitung nicht in Nähe der Stromkabel (230/400 V) verlegen.
- Stecken Sie keine spitzen Gegenstände in das Gerät und sorgen Sie dafür, dass keine Flüssigkeiten hineingelangen können.
- Kabelverlegung sowie Einbau und Wartung der elektrischen Geräte müssen von einem Elektrofachmann ausgeführt werden.
- Vor Wartungseingriffen immer erst die Spannungsversorgung unterbrechen.
- Den Modulträger an Masse anschließen (siehe Abb.).
- Die Gabel der Sprechgarnitur bei abgehobenem Hörer nicht gedrückt halten.
- Die Kamera darf nicht vor großen Lichtquellen oder an Stellen installiert werden, an denen das Motiv zu sehr im Gegenlicht steht. Zur Lösung des obigen Problems empfiehlt sich, die Kamera auf einer Höhe von 180 cm anstatt der üblichen 160 - 165 cm zu installieren, und das Objektiv nach unten zu richten, um die Qualität der Aufnahmen zu verbessern.
- Die Kameras mit CCD-Farbsensor haben bei schlechten Lichtverhältnissen eine geringere Empfindlichkeit als Schwarz/Weiß-Kameras. In schlecht beleuchteter Umgebung wird daher empfohlen, für eine zusätzliche Lichtquelle zu sorgen.

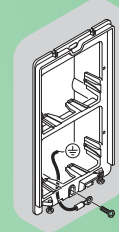

Allgemeines	67
Außenstelle	67
Art. 4882	67
Art. 1205/B	67
Installation der Außenstelle	68
Innensprechstellen	69
Einbau der Innensprechstelle Magis	69
Abnahme des Monitors	69
Art. 6402E	70
Beschreibung des Monitors	70
Art. 2608	71
Installation der Innensprechstelle Art. 2608	71
Allgemeine Installations- und Betriebshinweise	72
Tabelle der zulässigen Entfernungen der Geräte	72
Funktionsweise	72
Beschreibung Tasteneinstellungen und -funktionen	73
Einstellungen Monitor Art. 6402E und Innensprechstelle Style	73
TAB. A Adressen der Steigleitung	73
Beschreibung der Tastenfunktionen	73
Zusätzliche Haupt- oder Nebenmonitore	74
Default-Tastenkongfiguration	74
Allgemeine Hinweise zur Tastenprogrammierung	74
Tastenprogrammierung für allgemeine oder codierte Relaissteuerung	75
Programmierungen für Interngespräch	75
Programmierung/Löschung der Intercom-Adresse (nur für selektive Intercom-Verbindung)	75
TAB. B Adressen für selektive Intercom-Verbindung	75
Tastenprogrammierung für Interngespräch	76
Tastenprogrammierung für andere Funktionen	76
TAB. C Adressen der Steigleitung	77
Reset de Programmierung	77
Programmierung range/Ruftöne	78
Programmierung Eingang IN1 für Meldung LED/Alarm/Türöffner/Relais	79
Direkte Programmierung des Internrufs	80
Änderung der Monitor-Ruftöne	80
Besondere Programmierungen Art. 4882	81
Anschlusspläne	
MSK/012C Grundanschlussplan für Einfamiliensets Art. 8471MC. Inbetriebnahme/Spannungsprüfung an der Anlage in Standby.....	114
MSK/017AC Plan für Einfamilien-Set Art. 8471MC, erweitert mit einem zweiten Art. 4882	115
MSK/012/AC Schaltplan für Einfamilien-set mit zusätzlichem Netzteil Art. 1395	116
MSK/015C Einsatz des separaten Kameramoduls Art. 1259C	117
SB2/AAR Anschluss Videosignalverstärker Art. 4833C	118
MSK/HCA Zusätzliche Installation eines Hauptmonitors in Parallelschaltung, Kaskadenverbindung.....	118
MSK/IC Zusätzliche Installation eines Hauptmonitors in Parallelschaltung, Abzweigverbindung	119
MSK/A20S Anschluss in Kaskadenschaltung des dritten Hauptmonitors mit lokaler Stromversorgung	119
MSK/A23S Anschluss über Abzweigung von 2 Hauptmonitoren und 2 Zusatzmonitor mit identischem Teilnehmercode	120
MSK/A21S Anschluss über Abzweigung von 2 Hauptmonitoren und 1 Zusatzmonitor mit identischem Teilnehmercode	120
MSK/AAE Anschluss zusätzlicher Sprechstellen mit Abzweigung vom Monitor	121
MSK/AAD Anschluss zusätzlicher Sprechstellen in Kaskadenschaltung vom Monitor	121
MSK/FC Anschluss zusätzlicher Sprechstellen in Kaskadenschaltung vom Monitor.....	122
SB/X3 Verwendung von Taste P1 für sonstige Funktionen (Art. 2608).....	122
SB2V/AAK Anschluss von Rufwiederholeinrichtungen (Art. 1229 bzw. Art. 1122/A)	123
Anschlussvariante Rufsignale der Außensprechstellen	123

Verwendung des Eingangs IN1 als Meldekontakt LED/ALARM/TÜRÖFFNER/RELAIS. Aktivierung bei Schließen des Kontakts zwischen IN1 und CFP2	124
Verwendung des Eingangs IN1 als Meldekontakt LED/ALARM/TÜRÖFFNER/RELAIS. Aktivierung bei Anliegen von Spannung im gegenüber IN2	124
SB2/AAM2 Verwendung von Taste P1 für sonstige Funktionen	125
SMK/EC Anschluss Relais Art. 1256.....	125
GK/AAGC Variante mit Anschluss der zeitgesteuerten lokalen Türöffertaste.....	126
SMK/SNP Variante mit Sicherheits-Türöffner und zusätzlicher Stromversorgung.....	126
Verwendung des RC-Glieds als Türöffner-Filter an den Relaiskontakten.....	127

Allgemeines

Die Video-Türsprechanlagen als Einfamilienhaus-Set Art. 8471MC können in Wohngebäuden oder im Dienstleistungssektor verwendet werden, wo eine effektive Zugangskontrolle bei gleichzeitig einfachem Installationsaufwand gefordert ist.

Zur Aktivierung des Systems (Ruf, Sprechverbindung, Video, Selbsteinschaltung) sind lediglich 2 Leiter zwischen der Außensprechstelle und dem/den Monitor/en an der/den Innensprechstelle/n sowie 2 Drähte zur Versorgung der Außensprechstelle und des elektrischen Türöffners und 2 Drähte zur Versorgung der Video-Innensprechstelle erforderlich.

Zudem steht ein breites Angebot an Zubehörteilen zur Verfügung, um jeder Anlagenanforderung gerecht zu werden: Neben der Installation von interessanten Standard-Zubehörteilen kann eine bereits installierte Anlage durch Videosprech- und/oder Innensprechstellen und/oder Außenstellen erweitert werden. Somit sind in der Konfiguration als Einfamilienanlage bis zu 2 Außenstellen mit 4 Innensprechstellen (Sprech- und/oder Videosprechgeräte) möglich.

Über entsprechende Einstellungen können sowohl mit Videosprechstellen als auch mit Innensprechstellen Interngespräche innerhalb der Einfamilienanlage (d.h. zwischen Teilnehmern mit demselben Teilnehmercode) durchgeführt werden.

Mehrere Sets können an einen Simplebus Haupteingang und/oder eine Rufzentrale Art. 1998A angeschlossen werden.

Außenstelle

Art. 4882

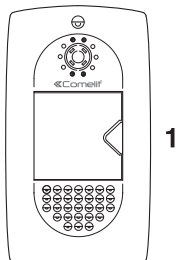

Art. 1205/B

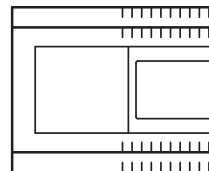

Technische Daten

Anschluss an Monitor mit 2 Leitern für Audio, Video, Türöffner und Ruf sowie 2 Leitern zur Versorgung von Art. 1205/B.

Hochempfindliche schwenkbare Videokamera mit CCD 1/3" Sensor.

Weißer LED-Beleuchtung (6 LED).

Namensschilder mit LED-Beleuchtung.

Lautstärkeeinstellung für Mikrofon und Lautsprecher.

Abmessungen des Unterputzgehäuses: 176,5x95,5x35 mm.

Die Taste von Art. 4882 ist werkseitig auf den Anruf an die Adresse 1 eingestellt.

Abmessung der Außenstelle: 176x95x15 mm.

Beschreibung der Klemmenleiste

LL Monitor-Anschluss (Video, Ruf, Sprechverbindung, Türöffner).

~ ~ Versorgung von Außenstelle.

RTE Eingang für zeitgesteuerten lokalen Türöffner.

SE. NC. - SE NO. - SE C. Anschluss elektrischer Türöffner.

Technische Daten

Der Transformator hat 2 Ausgänge: einen für die Versorgung der Außenstelle und des elektrischen Türöffners und einen für die Versorgung des Monitors.

Abmessungen: 105x85x85 mm (6 DIN-Module).

Träger Schutzsicherung 500 mA.

Beschreibung der Klemmenleiste

AC230V Eingang Netzspannung.

~ ~ AC-Ausgang für Außenstelle und Elektroschloss.

+ - Ausgang 20 V DC zur Versorgung des Monitors.

Installation der Außenstelle



Abb. 4 - ANM. Vor dem Festziehen der vier Schrauben erst prüfen, ob die Programmierung von Sonderfunktionen ausgeführt werden soll (siehe Seite 81).

Abb. 5 - ANM. Die vier Schrauben ein wenig lockern, um die Arretierung der Videokamera zu lockern.

Einbau der Innensprechstelle Magis

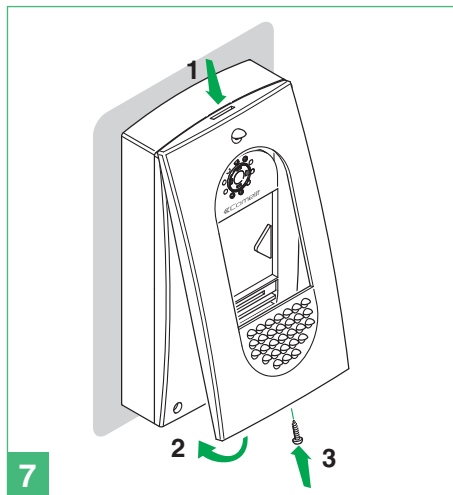
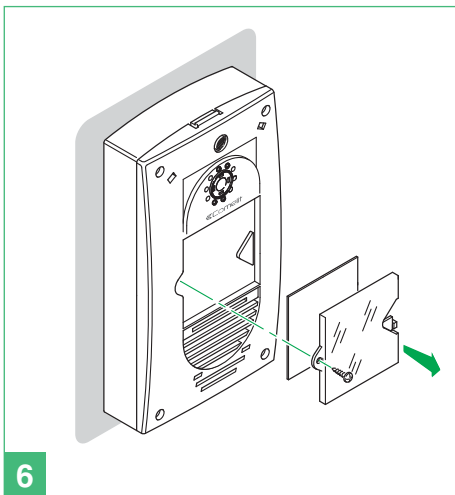
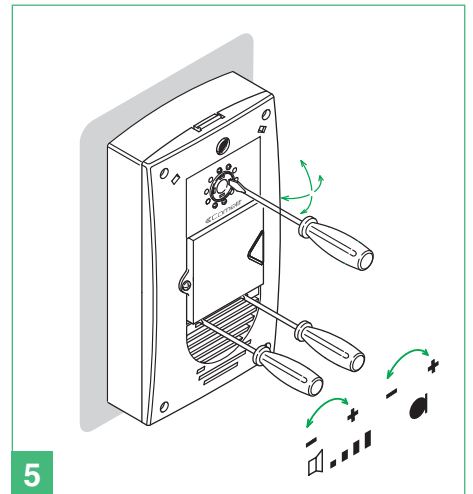
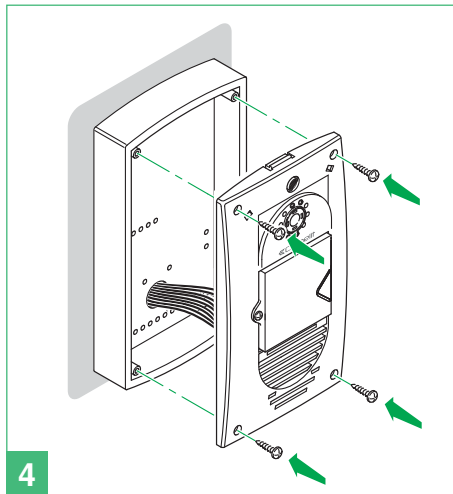
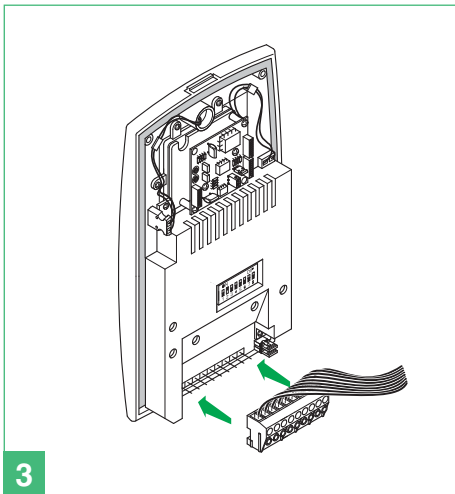
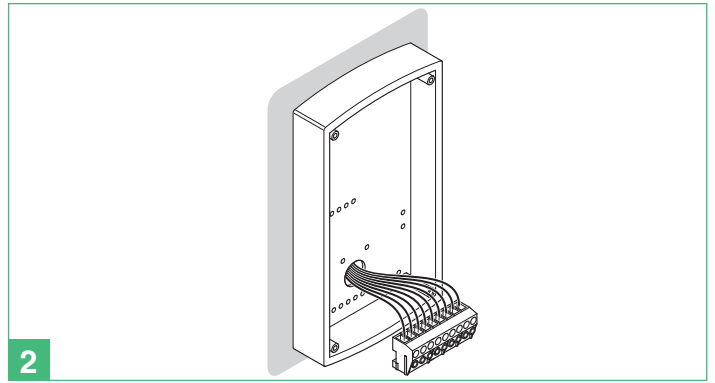
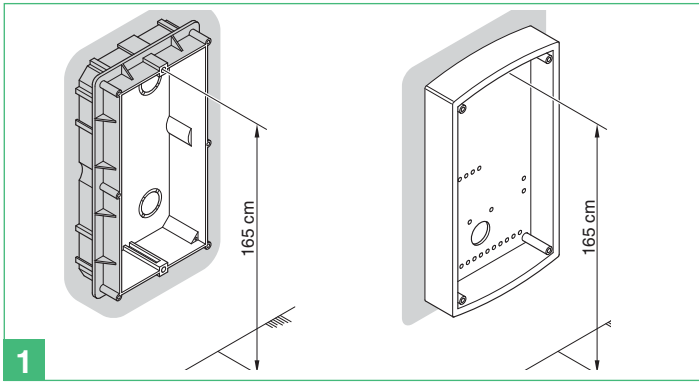
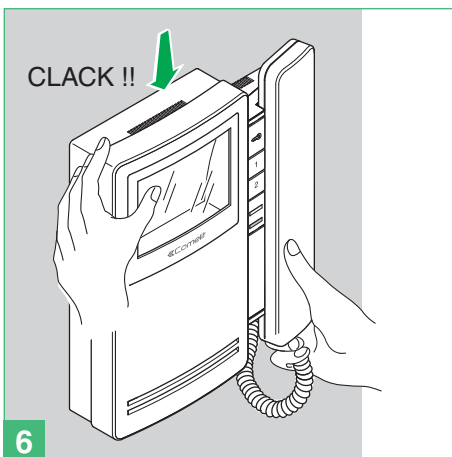
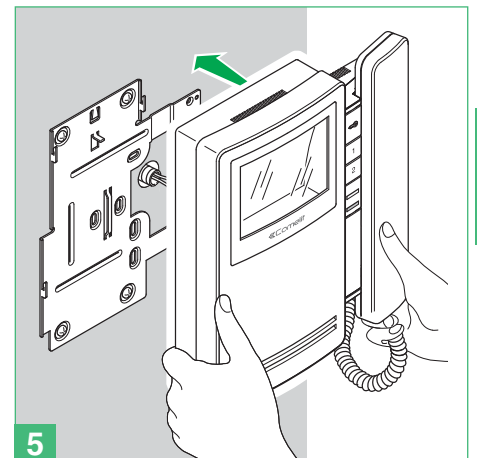
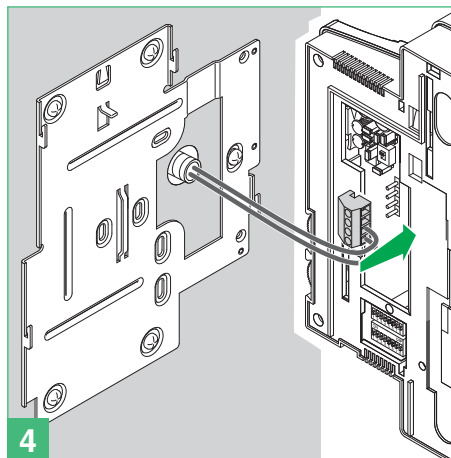
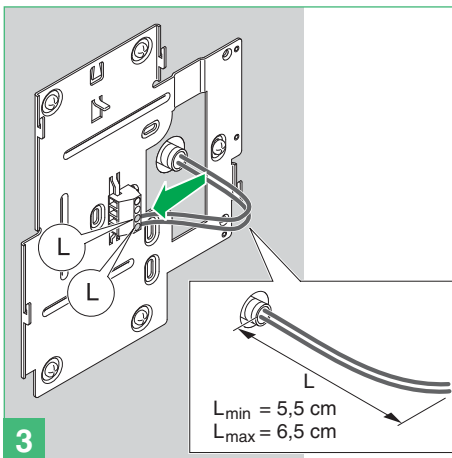
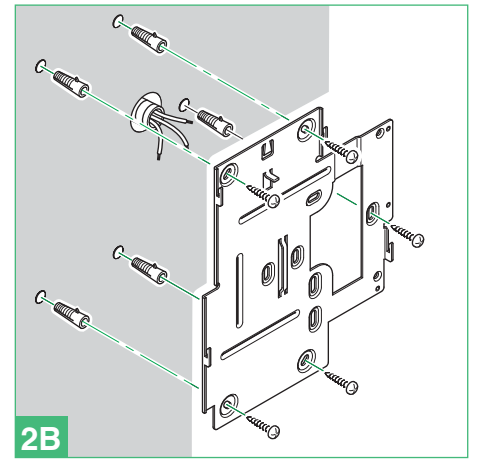
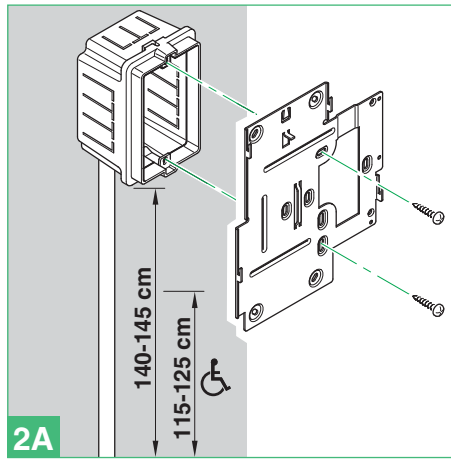
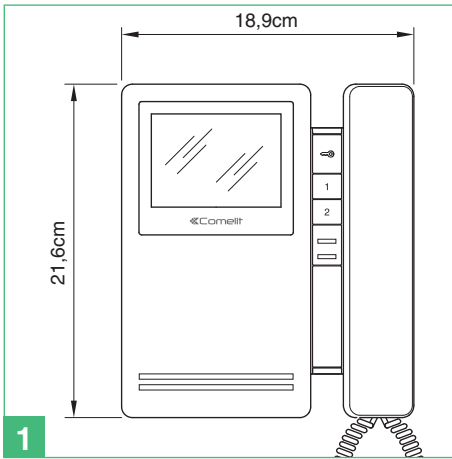

Abnahme des Monitors

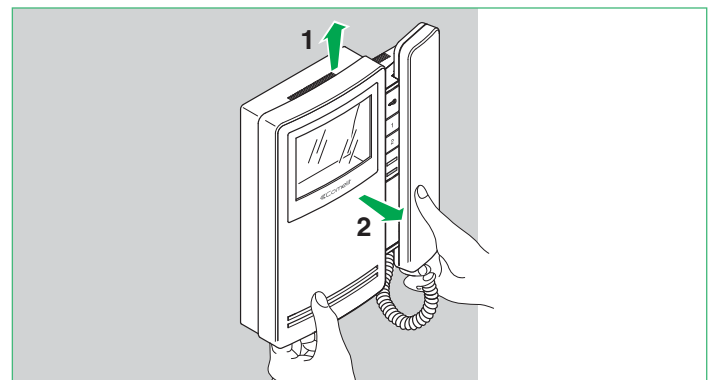

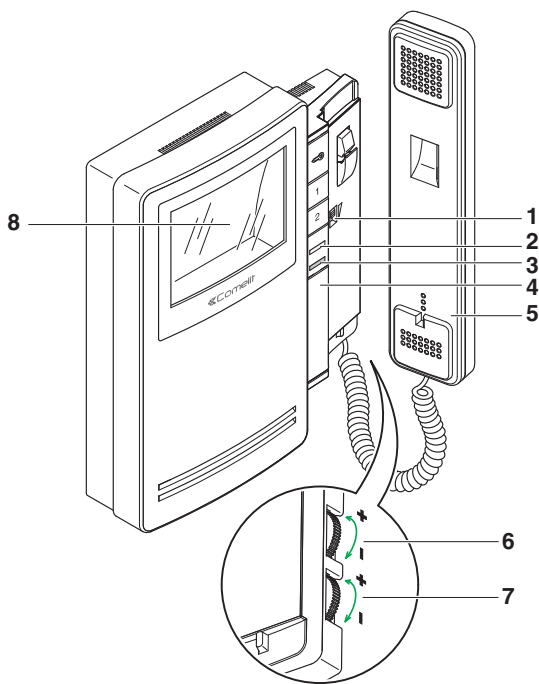

Monitorbeschreibung:

- 1 Einstellung Ruflautstärke/ Wahl- oder Funktionstaste Rufabschaltung (damit ist die Deaktivierung des Rufs von der Außenstelle und von Interngesprächen zwischen Sprech- und Videosprechstellen gemeint; die Aktivierung der Funktion Rufabschaltung wird durch das Einschalten einer roten Anzeige an der Seite des Wahlschalters angezeigt).
- 2 Anzeige-Led für Anlage besetzt/Arzt Ruf-Funktion aktiv/tür offen.
- 3 Rote Anzeige - Privacy aktiviert.
- 4 Einbaueinheit für Zusatzfunktionen mit Zubehör Art. 6333, Art. 6434.
- 5 Monitor-Hörer (den Hörer abnehmen, um mit der Kommunikation zu beginnen).
- 6 Drehregler für Farbintensitätsregelung.
▶ Gegen den Uhrzeigersinn drehen, um den Wert zu erhöhen.
- 7 Helligkeitsregler.
▶ Gegen den Uhrzeigersinn drehen, um den Wert zu erhöhen.
- 8 3,5" Farbbildschirm.

Beschreibung der Tasten:

- ☞ Türöffnertaste.
- 1 Taste 1 Standardrelais (programmierbar).
- 2 Taste 2 Selbsteinschaltung (programmierbar).

Beschreibung des Monitors

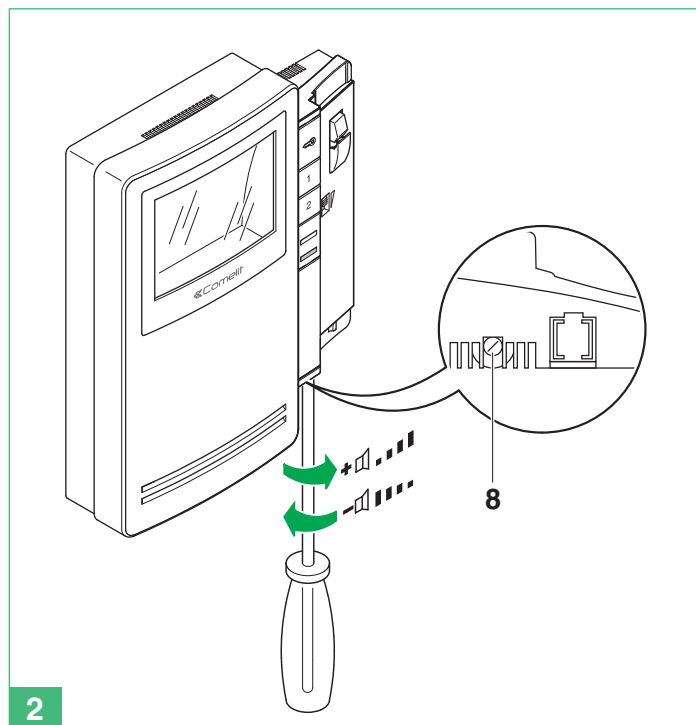
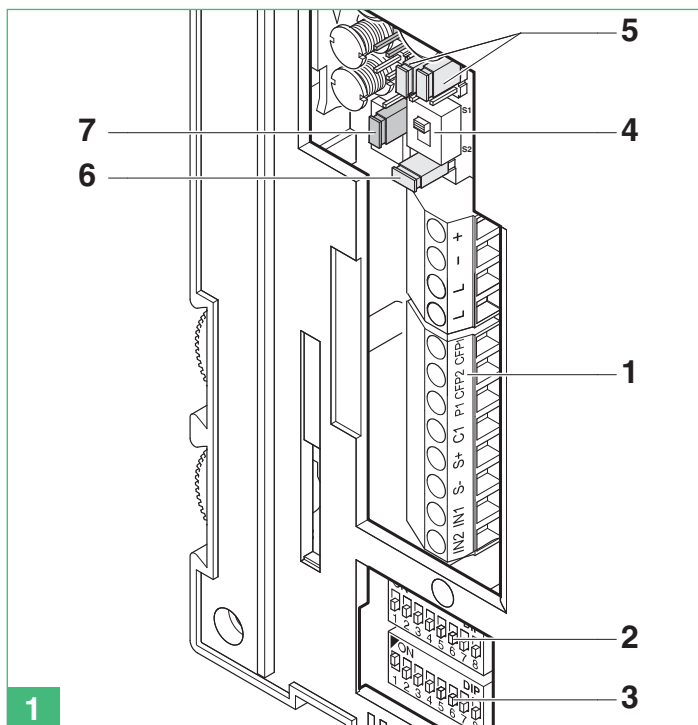

- 1 Klemmleiste für Anschluss an die Anlage:
+ - Klemmen für Stromversorgung.
L L Anschlussklemmen Busleitung.
CFP1 CFP2 Eingang Etagenruf.
P1 C1 Klemmen Taste 1 für Zusatzfunktionen.
Zur Herstellung eines Schließkontakts (max. 24V – 100mA) die Stecker CV3 und CV4 in Stellung B versetzen.
S+ S- Klemmen für Rufwiederholeinrichtung.
IN1 IN2 Eingang LED (programmierbar).
- 2 S1 Mikroschalter für Programmierung des Benutzercodes.
- 3 S2 Mikroschalter für die Programmierung der Tasten und Funktionen. (gekennzeichnet durch ein rotes Dreieck):
DIP 1-2-3-4 für die Programmierung der Tastenfunktionen.
DIP 5-6 öffnen der Programmierungen.
DIP 7 für die Einstellung der Versorgungsspannung (siehe Schaltpläne und Varianten ab Seite 114) Default = OFF.

- DIP 8:
ON Zusatz-Grundplatte.
OFF Haupt-Grundplatte (Default).
- 4 SW3 Wahlschalter für Modus Simplebus 1 (S1- Default) oder Simplebus 2 (S2).
- 5 CV3 CV4 Stecker für die Freigabe von Taste 1 (Schließkontakt 24V-100mA max.).
A Taste 1 Standardrelais (Default) oder programmierbar.
B Taste 1 für verschiedene Anwendungen.
- 6 CV5 Stecker zur Ausschaltung des Videosignals.
- 7 CV6 Wahlschalter für die Benutzung des Eingangs IN 1 (siehe Seite 124).
- 8 Lautstärkeregelung des Lautsprechers (nur für die Einstellung der Sprechleitung der Internkommunikation).

Nicht zur Nutzung der Funktion Gegensprechbetrieb verwendbar.
Die Innensprechstelle immer unter Verwendung von Art. 1214/2C, wie auf dem Anschlussplan MSK/FC auf Seite 122 dargestellt, installieren.

- 1 Anzeige Privacy.
- 2 Wahlschalter Rufon/Privacy mit 3 Stellungen:
Stellung oben: Rufon mit maximaler Lautstärke.
Mittelstellung: Rufon mit mittlerer Lautstärke.
Stellung unten: Aktivierung der Privacy-Funktion.
(Unter Privacy-Funktion ist die Deaktivierung des Rufs von der Außenstelle oder der Zentrale gemeint; die Aktivierung der Funktion Rufabschaltung wird durch das Aufleuchten einer roten LED rechts oben angezeigt).
- 3 Lautstärkeregler des Mikrofons.
- 4 Mikroschalter zur Einstellung des Teilnehmercodes.
- 5 Anschlussklemmen der Anlage:
LL Anschluss an Busleitung.
CFP CFP Eingang Etagenruf.
P1 C1 Klemmen der Taste P1 für Zusatzfunktionen Schließerkontakt 24V-100mA max) (CV1 und CV2 entfernen, siehe Variante SB/X3 Seite 122).
S+ S- Klemmen für Rufwiederholeinrichtung.
- 6 CV1 CV2 Jumper sind zu entfernen, um einen potentialfreien Schließer an Taste P1 herzustellen.
- 7A/7B JP1 Jumper zur Wahl der Funktion „Ruf an Pfortnerzentrale“ (Stellung C) bzw. Standardrelais (Stellung A) der Taste P1.

Beschreibung der Tasten:

- ☞ Türöffnertaste.
- P1 Taste P1 Ruf an Pfortnerzentrale / allgemeine Relaissteuerung / Taste für verschiedene Funktionen auf Klemmleiste (P1 C1).

Das Gerät mit einem feuchten Tuch reinigen. Dazu keinen Alkohol oder ähnliche aggressive Substanzen verwenden.

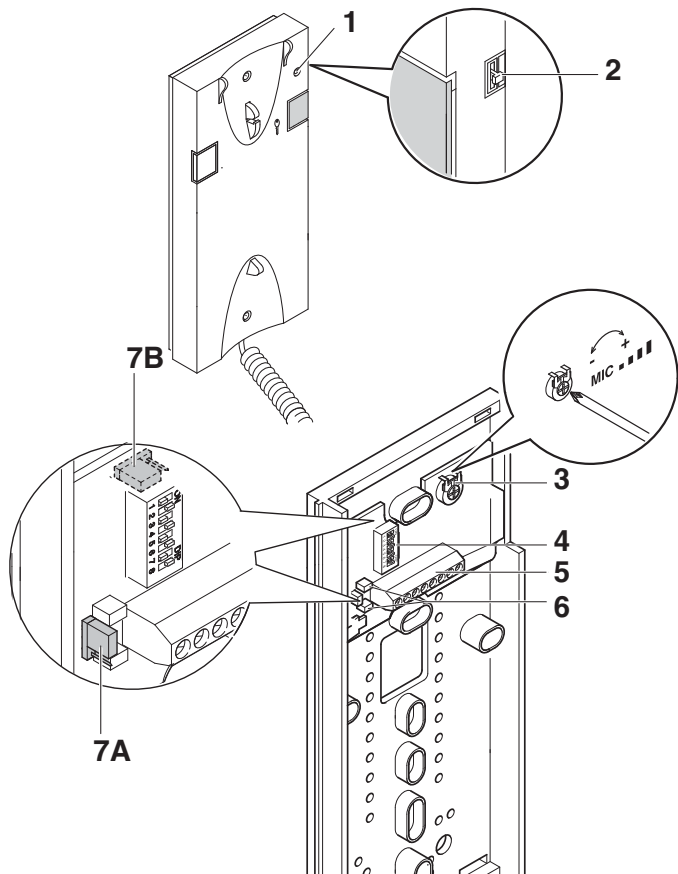

Installation der Innensprechstelle Art. 2608

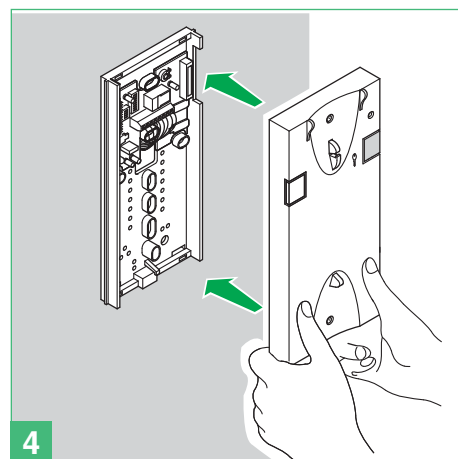
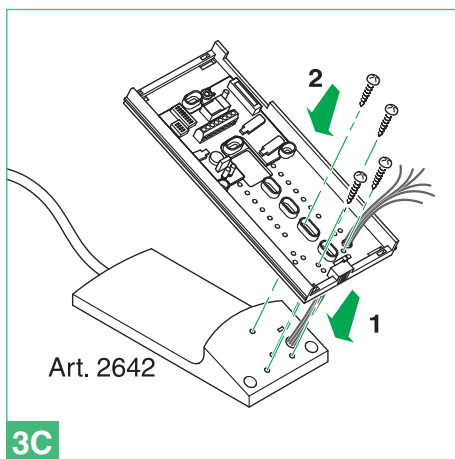
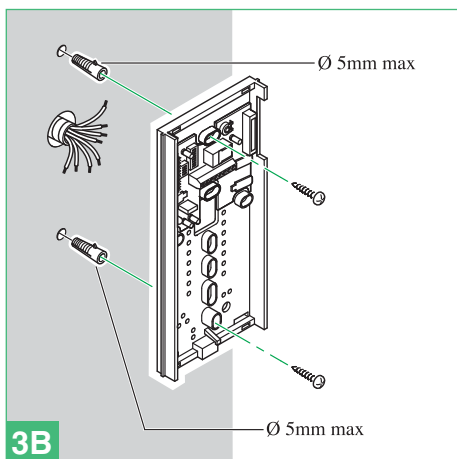
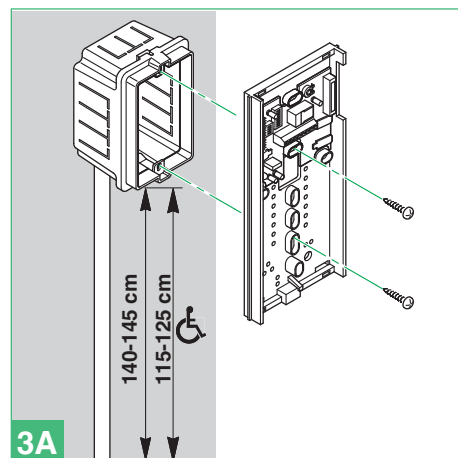
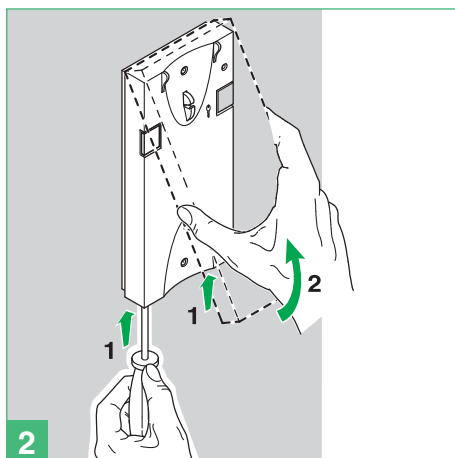
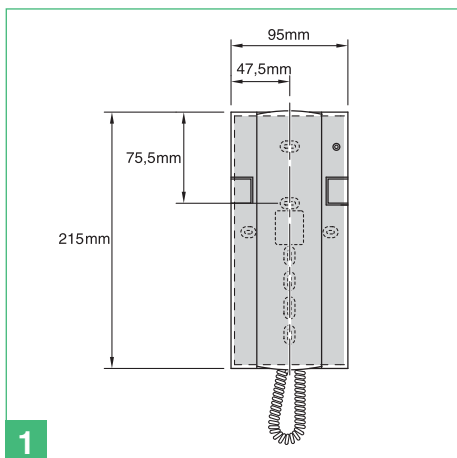

Allgemeine Installations- und Betriebshinweise

Die maximal zulässige Entfernung zwischen Außenstelle und entferntestem Monitor beträgt 400 m (mit Verstärker Art. 4833C).
 Die sich aus der Anzahl der Innenstellen mit dem gleichen Benutzercode und der Anzahl der mit diesen Innenstellen verbundenen Rufwiederholungsrichtungen ergebende Gesamtsumme darf nicht mehr als sein.
 Jeweils nur eine Rufwiederholeinrichtung pro Innensprechstelle anschließen.
 Die maximale Entfernung zwischen Innensprechstelle und Rufwiederholeinrichtung beträgt 20 m; zur Verbindung ist ein abgeschirmtes Kabel zu verwenden und die Kabel dürfen nicht in der Nähe von induktiven Belastungen oder von Stromkabeln (230V/400V) verlegt werden.

Tabelle der zulässigen Entfernungen der Geräte

		A/G MAX	B/E MAX	C MAX	D MAX	F MAX	Art. 1216
Comelit Art. 4577 1 mm ² (Ø 1,2 mm AWG 17)		50 m (165 feet)	50 m (165 feet)	200 m (655 feet)	100 m (330 feet)	150 m (495 feet)	
Comelit Art. 4576-4578	0,5 mm ² (Ø 0,8 mm AWG 20) bus		25 m (85 feet)	200 m (655 feet)	100 m (330 feet)	150 m (495 feet)	
	1,5 mm ² (Ø 1,4 mm AWG 15) power	75 m (245 feet)	100 m (330 feet)				
UTP5 cat. 5 0,2 mm ² (Ø 0,5 mm AWG 24)				190 m (625 feet)	60 m (195 feet)	150 m (495 feet)	
0,28 mm ² (Ø 0,6 mm AWG 23)		5 m (15 feet)		190 m (625 feet)	60 m (195 feet)	150 m (495 feet)	
0,5 mm ² (Ø 0,8 mm AWG 20)		25 m (85 feet)	25 m (85 feet)	190 m (625 feet)	60 m (195 feet)	150 m (495 feet)	
1 mm ² (Ø 1,2 mm AWG 17)		50 m (165 feet)	50 m (165 feet)	190 m (625 feet)	60 m (195 feet)	150 m (495 feet)	
1 mm ² (Ø 1,2 mm AWG 17)		50 m (165 feet)	50 m (165 feet)	120 m (395 feet)	40 m (130 feet)	100 m (330 feet)	
1,5 mm ² (Ø 1,4 mm AWG 15)		75 m (245 feet)	100 m (330 feet)	190 m (625 feet)	60 m (195 feet)	150 m (495 feet)	
2,5 mm ² (Ø 1,8 mm AWG 13)		100 m (330 feet)	150 m (495 feet)	190 m (625 feet)	60 m (195 feet)	150 m (495 feet)	

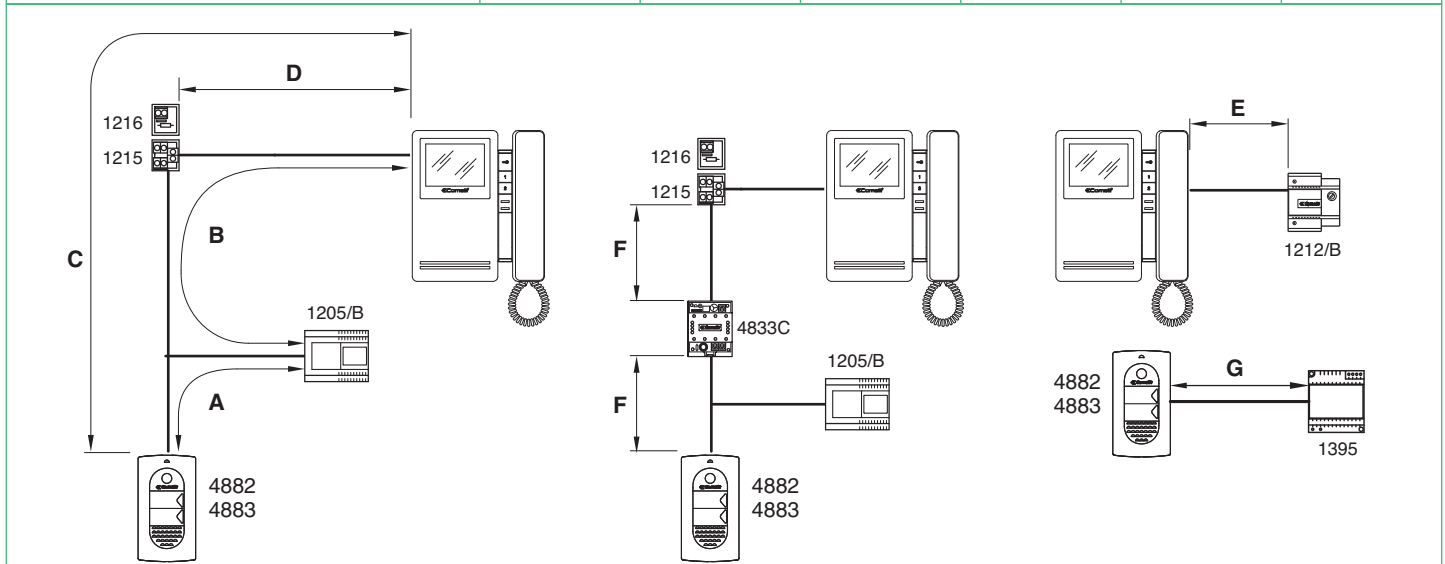

Funktionsweise



Im Falle eines anhaltenden Kurzschlusses auf der Buslinie gibt die Außenstelle einen intermittierenden Signalton aus.

Durch Drücken der Ruftaste schaltet der Besucher die Beleuchtung des Motivs ein, löst den Rufton der Innensprechstelle aus (insofern die Privacy-Funktion nicht aktiviert ist) und lässt sein Bild für ca. 60 Sek. auf dem/den Hauptmonitor/en erscheinen.
 Die maximale Gesprächsdauer zwischen Außenstelle und Innensprechstelle beträgt 90 Sekunden.
 An der Außenstelle ist ein Ton zu hören, mit dem der erfolgte Ruf bestätigt wird; ist bei Anlagen mit zwei oder mehreren Eingängen zum Zeitpunkt des Rufs ein Besetztzeichen anstelle der Wiederholung des Ruftons zu hören, bedeutet dies, dass bereits eine Kommunikation mit einer anderen Außenstelle stattfindet.
 Für die Programmierung von anderen als den werkseitig eingestellten Benutzeradressen (1 und 2) siehe Seite 73.
 Für die Intercom-Funktionen des Systems Magis Kit siehe Seite 75.

Beschreibung Tasteneinstellungen und -funktionen

Einstellungen Monitor Art. 6402E und Innensprechstelle Style

Stellung der Mikroschalter des Monitors Art. 6402E

► An den Innensprechstellen Art. 2608, Art. 2610 und Art. 2628 die Dipschalter **S1-6, S1-7, S1-8** auf **OFF** setzen.

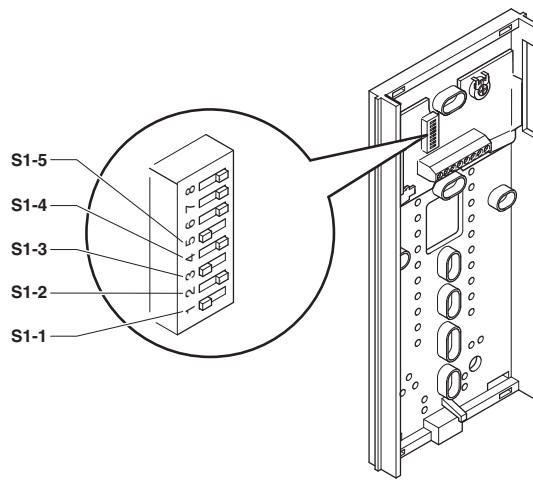
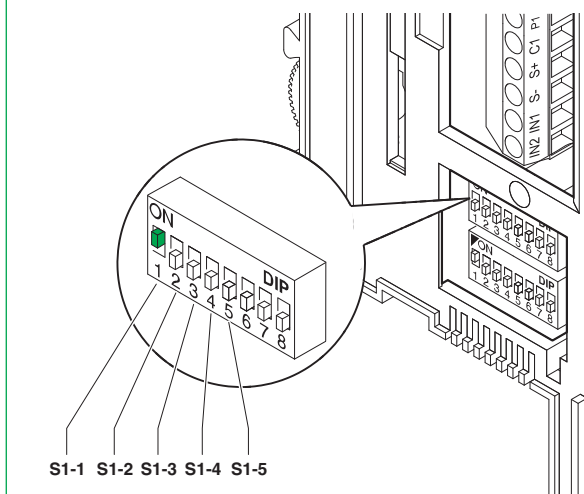

Die Werte **S1-1, S1-2, S1-3, S1-4** und **S1-5** definieren die **Rufadresse** des Monitors und der Innensprechstellen gemäß folgender Tabelle.

TAB. A Adressen der Steigleitung

Code	S1
1	

Beschreibung der Tastenfunktionen

☞ **Türöffner:** Durch Drücken der Türöffnertaste aktiviert sich das mit der Außenstelle verbundene Schloss.

Antrieb: Durch Drücken der auf die Betriebsart Antrieb eingestellten Taste lässt sich Art. 1256 aktivieren, der zum Beispiel zur Öffnung von Toren, Kipptoren oder zur Aktivierung des Moduls zyklische Videokameras Art. 1259C genutzt werden kann.

Unbelegte Taste Die Angabe Unbelegte Taste weist auf die Möglichkeit hin, die Taste als Schließerkontakt an der Klemmenleiste nach entsprechenden Einstellungen, wie in der Variante SB2/AAM2 auf Seite 125 dargestellt, zu nutzen.

Selbsteinschaltung / Video-Anforderung

- ✓ Die Selbsteinschaltung kann deaktiviert werden.
- ✓ Die Selbsteinschaltung ist nur möglich, wenn sich die Anlage in Standby befindet.
- ✓ Die Funktion Selbsteinschaltung wird nur für Anlagen mit 1 oder 2 Eingängen empfohlen.

Durch Drücken der auf diese Betriebsart eingestellten Taste 2 lässt sich das von der Außenstelle gesendete Bild am Bildschirm anzeigen, auch wenn kein Ruf getätigt wurde.

Bei Anlagen mit 2 Außenstellen lässt sich abwechselnd das Bild der einen oder der anderen Außenstelle ('Pendelfunktion') anzeigen, indem die Taste 2 mehrmals nacheinander gedrückt wird.

An den Zusatzmonitoren (DIP 8 von S2 auf ON) hat die Taste 2 auch die Funktion der Video-Anforderung und dient zum Einschalten eines Monitors nach einem Ruf von der Außenstelle.

Aktivierung:

- Die Selbsteinschalttaste des Monitors länger als 4 Sek. gedrückt halten.
- » Klingelton zur Bestätigung.

Deaktivierung:

- Die Selbsteinschalttaste des Monitors länger als 4 Sek. gedrückt halten.

»4 Bestätigungstöne

Einschaltung:

- Die entsprechende Taste (Taste 2, falls die werkseitigen Einstellungen beibehalten wurden) drücken und sofort wieder loslassen.

Ruf an Pförtnerzentrale

Durch Drücken der auf diese Betriebsart eingestellten Taste lässt sich ein Ruf an die Pförtnerzentrale senden.

Einfamilienhaus-Internruf

Diese Funktion ermöglicht, einen Ruf an die anderen Geräte (Video- und /oder Innensprechstellen) zu tätigen, die auf dieselbe Rufadresse eingestellt sind.

- Wenn der Empfänger des Anrufs den Hörer abnimmt, nimmt er mit dem Anrufer Verbindung auf. Durch Auflegen des Hörers wird die Kommunikation beendet.

Interngespräche haben keinen Vorrang vor einem Gespräch/Ruf mit der Außenstelle. In diesem Fall blinkt bei einem versuchten Interngespräch die LED für einige Sekunden, um zu melden, dass das System besetzt ist.

Anrufen von einer Außenstelle

Ein von einer Außensprechstelle eingehender Anruf hat jedoch zu jeder Zeit Vorrang vor einem Interngespräch. (Die Aufnahme des Gesprächs mit der Außenstelle unterbricht das zuvor laufende Interngespräch). In diesem Fall vernehmen die bereits an einem Gespräch beteiligten Benutzer einen Ton, der dem eines an sie gerichteten Rufs ähnelt, oder andernfalls drei Signaltöne.

- Um den von der Außenstelle eingehenden Ruf anzunehmen, nur den Hörer von jedem beliebigen freien Gerät abnehmen oder den Hörer von einem am Interngespräch beteiligten Gerät abnehmen und wieder auflegen.

Arztruf

Diese Funktion gestattet die automatische Betätigung des Türöffners bei Ruf von der Außenstelle an die Adresse der Innensprechstelle, an der die Funktion aktiviert wurde.

Aktivierung / Deaktivierung:

- Die auf diese Funktion eingestellte Taste 2 Sek. lang gedrückt halten
- »Bei aktivierter Funktion bleibt die Anzeige-LED eingeschaltet.

Zusätzliche Haupt- oder Nebenmonitore

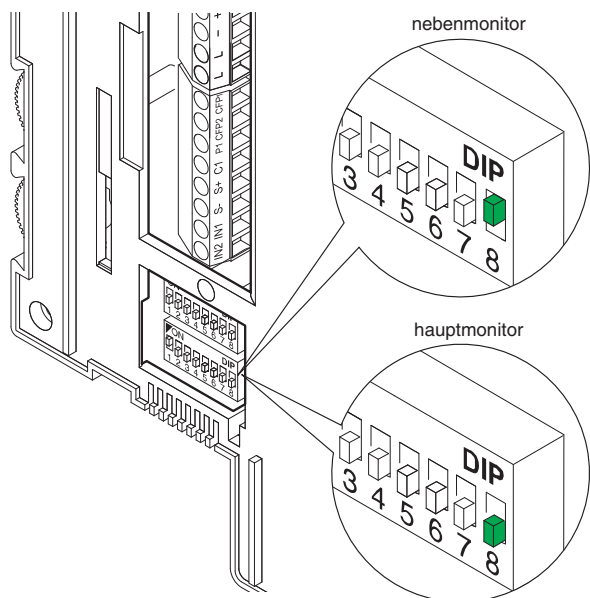

Mit der Einstellung des DIP-Schalters 8 von S2 wird festgelegt, ob die betreffende Grundplatte als Haupt- (P) oder Nebensprechstelle (S) verwaltet wird.

Die Außenstelle ist für die Steuerung von maximal 4 Videosprech- oder Innensprechstellen pro Rufaste ausgelegt.

In der klassischen Konfiguration von Magis Kit können demnach maximal 2 Haupt-Videosprechstellen und 2 Neben-Videosprechstelle je Rufaste installiert werden, deren Versorgung stets durch den Art. 1205/B erfolgt.

Es besteht die Möglichkeit, bis zu 3 Haupt-Videosprechstellen innerhalb der gleichen Wohnung (d.h. mit Einstellung auf den gleichen Teilnehmercode) zu steuern. In dieser besonderen Konfiguration müssen die zusätzlichen Haupt-Videosprechstellen von dem hierfür vorgesehenen Art. 1212/B versorgt werden (siehe Variante MSK/HCA, MSK/IC Seite 118, 119). Geht ein Ruf von der Außenstelle aus, ist der eingeschaltete Monitor die Haupt-Videosprechstelle.

Die eventuell vorhandenen Nebenmonitore der gleichen Wohnung bleiben ausgeschaltet.

Wird der Ruf der Außenstelle von einer Nebenvideosprechstelle beantwortet, erscheint das Bild automatisch am Monitor.

Nun wird der Monitor der Haupt-Videosprechstelle ausgeschaltet und das Bild am Monitor der Videosprechstelle angezeigt, deren Taste 2 - Selbsteinschaltung/Video-Anforderung gedrückt wird.

Zur Anzeige des Bildes ohne Aktivierung der Sprechverbindung mit der Außenstelle die Taste 2- Selbsteinschaltung/Video-Anforderung drücken.

DE

Default-Tastenkonfiguration

DIP S2								mit Art. 6433, 6434			
DIP 1	DIP 2	DIP 3	DIP 4	P1	P2	🔑	☎	P3	P4	P5	P6
0	0	0	0	CCS	AI			ACT	D	PAN	K
1	0	0	0	ACT	AI	🔑		INT	INTb	D	CCS
0	1	0	0	INT	AI			INTb	ACT	CCS	CCP
1	1	0	0	ACT	CCS			CCP	PAN	K	D
0	0	1	0	ACT	ACT	ACT		ACT	ACT	ACT	ACT
1	0	1	0	INT	ACT			CCS	CCP	INTb	PAN
0	1	1	0	AI	D			K	CCS	CCP	INTb
1	1	1	0	INTb	INT		☎	AI	INT	PAN	D
0	0	0	1	CCS	PAN			D	AI	INT	INTb
1	0	0	1	K	CCS	🔑		PAN	CCP	AI	INT
0	1	0	1	CCP	K			PAN	ACT	INT	AI
1	1	0	1	PAN	CCP			CCS	K	ACT	D
0	0	1	1	D	INTb			INT	ACT	AI	CCS
1	0	1	1	INT	INT			INT	INT	INT	INT
0	1	1	1	NULL	NULL	NULL	NULL	NULL	NULL	NULL	NULL
1	1	1	1						PROG		

Legende

🔑	Türöffnertaste	CCS	Ruf an Pfortnerzentrale	INTb	Intercom Zweifamilienhaus - nur für KIT
☎	Sprechverbindung	K	Ruf an Wechselsprechgerät des Wachmanns	NULL	Keine Funktion
ACT	Relais	D	Arzttruf	PROG	Programmierte Funktionen beschrieben, siehe Seiten 74-75-76-77 In dieser Stellung der DIP-Schalter betätigen die Tasten die programmierten Funktionen; Die NICHT programmierten Tasten betätigen die Funktionen der Zeile 0000
AI	Selbsteinschaltung	PAN	Notruf		
CCP	Ruf an Haupt-Pfortnerzentrale	INT	Intercom programmierbar allgemein oder selektiv - serienmäßig Ruf Einfamilienhaus für KIT und Simplebus Top		



Allgemeine Hinweise zur Tastenprogrammierung

Falls die Default-Konfigurationen (siehe Tabelle auf Seite 74) nicht den Anforderungen entsprechen, können die Tasten wie nachstehend beschrieben umprogrammiert werden.

Am Schluss die DIP-Schalter 1-2-3-4 von S2 auf Kombination 1111 stellen (Einstellung PROG in den Konfigurations-Tabellen Seite 74-75-76-

77). Wenn die DIP-Schalter so eingestellt sind, betätigen die Tasten die programmierten Funktionen; die NICHT programmierten Tasten betätigen die Funktionen der Zeile 0000 (siehe Tabelle Seite 74). Die Einstellung des Benutzercodes auf S1 wieder herstellen, siehe Tabelle A auf Seite 73.

Tastenprogrammierung für allgemeine oder codierte Relaissteuerung

DIP S2				mit Art. 6433, 6434						DIP S1			
DIP 1	DIP 2	DIP 3	DIP 4	P1	P2			P3	P4	P5	P6	ADRESSE 12345678	
0	0	0	0					ACT					
1	0	0	0	ACT									
0	1	0	0						ACT				
1	1	0	0	ACT									
0	0	1	0	ACT	ACT	ACT		ACT	ACT	ACT	ACT		
1	0	1	0		ACT								
0	1	1	0										
1	1	1	0										
0	0	0	1										
1	0	0	1										
0	1	0	1						ACT				
1	1	0	1							ACT			
0	0	1	1										
1	0	1	1										
0	1	1	1										
1	1	1	1										
PROG													

Beispiel:

Am Monitor mit Benutzercode 5 Programmierung P1= allgemeine Relaissteuerung, P2= codierte Relaissteuerung mit Code 125.

- DIP-Schalter 5-6 von S2 auf die Kombination 01 stellen.
» Die (grüne) LED blinkt.

- In der Tabelle auf Seite 75 eine Kombination wählen, in der für die Tasten, die programmiert werden sollen, die Funktion Relais (ACT) erscheint.

BEISPIEL: Für P1= allgemeine Relaissteuerung die DIP-Schalter 1-2-3-4 von S2 auf die Kombination 1000 oder 1100 oder 0010 (P1=ACT) stellen, DIP-Schalter von S1 auf die Kombination 11111111 stellen, weiter mit Punkt 3.

BEISPIEL: Für P2= Codierte Relaissteuerung mit Code 125 die DIP-Schalter 1-2-3-4 von S2 auf die Kombination 0010 oder 1010 (P2=ACT)

stellen, S1 gemäß **Tabelle C** auf Seite 77 mit Adresse 125 einstellen, weiter mit Punkt 3.

- Die Taste, der die Funktion zugewiesen werden soll, drücken und gedrückt halten.

» Die (grüne) LED leuchtet auf.

» Bestätigungston im Hörer.

- Zum Beenden der Programmierung die DIP-Schalter 5-6 von S2 auf die Kombination 00 stellen.

» Die (grüne) LED erlischt.

- Am Ende der Programmierung die DIP-Schalter 1-2-3-4 von S2 auf die Kombination 1111 stellen. Die Einstellung des Benutzercodes auf S1 wieder herstellen, siehe Tabelle A auf Seite 73.

DE

Programmierungen für Interngespräch



Allgemeine und selektive Intercom-Verbindungen sind **NICHT** an derselben Steigleitung möglich.

Programmierung/Löschung der Intercom-Adresse (nur für selektive Intercom-Verbindung)

S1	! 2)						S2	3)
	DIP 1	DIP 2	DIP 3	DIP 4	DIP 5	DIP 6		
! 1) Programmierung; eingabe des Codes, TAB. B seite 75	0	0	0	1	1	1	 	 2 sek
! Löschchen 	1	1	1	1	1	1	 	



Die Einstellung von S2, S1 notieren und nach Abschluss der Programmierung wieder herstellen.

TAB. B Adressen für selektive Intercom-Verbindung

Code	Dip switch ON	S1	Code	Dip switch ON	S1	Code	Dip switch ON	S1
1	1		4	4		7	7	
2	2		5	5		8	8	
3	3		6	6				

Die Intercom-Adresse muss an allen Innensprechstellen der Steigleitung eingerichtet werden. Dieselbe Intercom-Adresse kann maximal 3 Innensprechstellen zugeordnet werden. Für den Gruppenruf die gewünschten Intercom-Codes gleichzeitig wählen (max. 3).

Tastenprogrammierung für Interngespräch

DIP S2								mit Art. 6433, 6434				DIP S1	
DIP 1	DIP 2	DIP 3	DIP 4	P1	P2			P3	P4	P5	P6	ADRESSE 	
0	0	0	0										
1	0	0	0					INT	INTb				
0	1	0	0	INT				INTb					
1	1	0	0										
0	0	1	0										
1	0	1	0	INT						INTb			
0	1	1	0								INTb		
1	1	1	0	INTb	INT				INT				
0	0	0	1							INT	INTb		
1	0	0	1								INT		INT
0	1	0	1							INT			
1	1	0	1					INT					
0	0	1	1		INTb			INT	INT	INT	INT		
1	0	1	1	INT	INT			INT	INT	INT	INT		
0	1	1	1										
1	1	1	1										
PROG													

Beispiel 1 - Selektivem Internruf

Am Monitor mit Benutzercode 1 und Intercom-Adresse 1 Programmierung P3= Intercom selektiv mit Adresse 2, P4= Intercom selektiv mit Adresse 3.

Beispiel 2 - Internruf KIT (Intercom-Verbindung zwischen 2 benachbarten Adressen von 1 bis 30, davon die erste ungerade):

Am Monitor mit Benutzercode 1 Programmierung P3= Interner Gruppenruf, P4= Intercom Zweifamilienhaus mit Adresse 2.

- DIP-Schalter 5-6 von S2 auf die Kombination 01 stellen.
» Die (grüne) LED blinkt.
- In der Tabelle auf Seite 76 eine Kombination wählen, in der für die Tasten, die programmiert werden sollen, die Funktion Intercom (INT oder INTb) erscheint.

BEISPIEL 1: Für P3= Intercom selektiv die DIP-Schalter 1-2-3-4 von S2 auf die Kombination 1000 oder 0011 (P3=INT) stellen, S1 gemäß **Tabelle B** auf Seite 75 mit Adresse 2 einstellen, weiter mit Punkt 3.

BEISPIEL1: Für P4= Intercom selektiv die DIP-Schalter 1-2-3-4 von S2 auf die Kombination 1110 oder 1011 (P4=INT) stellen, S1 gemäß **Tabelle**

B auf Seite 75 mit Adresse 3 einstellen, weiter mit Punkt 3.

BEISPIEL 2: Für P3= Interner Gruppenruf und P4= Intercom Zweifamilienhaus die DIP-Schalter 1-2-3-4 von S2 auf die Kombination 1000 (P3=INT, P4=INTb) stellen, S1 gemäß **Tabelle A** auf Seite 73 mit Benutzercode 1 einstellen, weiter mit Punkt 3.

- Die Taste, der die Funktion zugewiesen werden soll, drücken und gedrückt halten.
» Die (grüne) LED leuchtet auf.
» Bestätigungston im Hörer.
- Zum Beenden der Programmierung die DIP-Schalter 5-6 von S2 auf die Kombination 00 stellen.
» Die (grüne) LED erlischt.
- Am Ende der Programmierung die DIP-Schalter 1-2-3-4 von S2 auf die Kombination 1111 stellen. Die Einstellung des Benutzercodes auf S1 wieder herstellen, siehe Tabelle A auf Seite 73.**

Tastenprogrammierung für andere Funktionen

DIP S2								mit Art. 6433, 6434			
DIP 1	DIP 2	DIP 3	DIP 4	P1	P2			P3	P4	P5	P6
0	0	0	0	CCS	AI				D	PAN	K
1	0	0	0		AI					D	CCS
0	1	0	0		AI					CCS	CCP
1	1	0	0		CCS			CCP	PAN	K	D
0	0	1	0								
1	0	1	0					CCS	CCP		PAN
0	1	1	0	AI	D			K	CCS	CCP	PAN
1	1	1	0					AI		PAN	D
0	0	0	1	CCS	PAN			D	AI		
1	0	0	1	K	CCS			PAN	CCP	AI	
0	1	0	1	CCP	K			PAN			AI
1	1	0	1	PAN	CCP			CCS	K		D
0	0	1	1	D						AI	CCS
1	0	1	1								
0	1	1	1	NULL	NULL	NULL	NULL	NULL	NULL	NULL	NULL
PROG											

Legende

	Turöffnertaste	CCS	Ruf an Pfortnerzentrale	NULL	Keine Funktion
	Sprechverbindung	K	Ruf an Wechselsprechgerät des Wachmanns	PROG	Programmierte Funktionen
AI	Selbsteinschaltung	D	Arzt Ruf		
CCP	Ruf an Haupt-Pfortnerzentrale	PAN	Notruf		

Beispiel:

Am Monitor mit Benutzercode 5 Programmierung P5= Selbsteinschaltung, P6= Ruf an Pfortnerzentrale.

- DIP-Schalter 5-6 von S2 auf die Kombination 01 stellen.
» Die (grüne) LED blinkt.
- In der Tabelle auf Seite 76 eine Kombination wählen, in der die gewünschten/erforderlichen Funktionen für die zu programmierenden Tasten erscheinen.

BEISPIEL: Für P5= Selbsteinschaltung P6= Ruf an Pfortnerzentrale die DIP-Schalter 1-2-3-4 von S2 auf die Kombination 0011 stellen (P5=AI, P6=CCS).



- Die Taste, der die Funktion zugewiesen werden soll, drücken und gedrückt halten.
» Die (grüne) LED leuchtet auf.
» Bestätigungston im Hörer.
- Zum Beenden der Programmierung die DIP-Schalter 5-6 von S2 auf die Kombination 00 stellen.
» Die (grüne) LED erlischt.
- Am Ende der Programmierung die DIP-Schalter 1-2-3-4 von S2 auf die Kombination 1111 stellen.**

TAB. C Adressen der Steigleitung

Code	Dip switch ON	Code	Dip switch ON	Code	Dip switch ON	Code	Dip switch ON	Code	Dip switch ON	Code	Dip switch ON	Code	Dip switch ON	Code	Dip switch ON
1	1	31	1,2,3,4,5	61	1,3,4,5,6	91	1,2,4,5,7	121	1,4,5,6,7	151	1,2,3,5,8	181	1,3,5,6,8	211	1,2,5,7,8
2	2	32	6	62	2,3,4,5,6	92	3,4,5,7	122	2,4,5,6,7	152	4,5,8	182	2,3,5,6,8	212	3,5,7,8
3	1,2	33	1,6	63	1,2,3,4,5,6	93	1,3,4,5,7	123	1,2,4,5,6,7	153	1,4,5,8	183	1,2,3,5,6,8	213	1,3,5,7,8
4	3	34	2,6	64	7	94	2,3,4,5,7	124	3,4,5,6,7	154	2,4,5,8	184	4,5,6,8	214	2,3,5,7,8
5	1,3	35	1,2,6	65	1,7	95	1,2,3,4,5,7	125	1,3,4,5,6,7	155	1,2,4,5,8	185	1,4,5,6,8	215	1,2,3,5,7,8
6	2,3	36	3,6	66	2,7	96	6,7	126	2,3,4,5,6,7	156	3,4,5,8	186	2,4,5,6,8	216	4,5,7,8
7	1,2,3	37	1,3,6	67	1,2,7	97	1,6,7	127	1,2,3,4,5,6,7	157	1,3,4,5,8	187	1,2,4,5,6,8	217	1,4,5,7,8
8	4	38	2,3,6	68	3,7	98	2,6,7	128	8	158	2,3,4,5,8	188	3,4,5,6,8	218	2,4,5,7,8
9	1,4	39	1,2,3,6	69	1,3,7	99	1,2,6,7	129	1,8	159	1,2,3,4,5,8	189	1,3,4,5,6,8	219	1,2,4,5,7,8
10	2,4	40	4,6	70	2,3,7	100	3,6,7	130	2,8	160	6,8	190	2,3,4,5,6,8	220	3,4,5,7,8
11	1,2,4	41	1,4,6	71	1,2,3,7	101	1,3,6,7	131	1,2,8	161	1,6,8	191	1,2,3,4,5,6,8	221	1,3,4,5,7,8
12	3,4	42	2,4,6	72	4,7	102	2,3,6,7	132	3,8	162	2,6,8	192	7,8	222	2,3,4,5,7,8
13	1,3,4	43	1,2,4,6	73	1,4,7	103	1,2,3,6,7	133	1,3,8	163	1,2,6,8	193	1,7,8	223	1,2,3,4,5,7,8
14	2,3,4	44	3,4,6	74	2,4,7	104	4,6,7	134	2,3,8	164	3,6,8	194	2,7,8	224	6,7,8
15	1,2,3,4	45	1,3,4,6	75	1,2,4,7	105	1,4,6,7	135	1,2,3,8	165	1,3,6,8	195	1,2,7,8	225	1,6,7,8
16	5	46	2,3,4,6	76	3,4,7	106	2,4,6,7	136	4,8	166	2,3,6,8	196	3,7,8	226	2,6,7,8
17	1,5	47	1,2,3,4,6	77	1,3,4,7	107	1,2,4,6,7	137	1,4,8	167	1,2,3,6,8	197	1,3,7,8	227	1,2,6,7,8
18	2,5	48	5,6	78	2,3,4,7	108	3,4,6,7	138	2,4,8	168	4,6,8	198	2,3,7,8	228	3,6,7,8
19	1,2,5	49	1,5,6	79	1,2,3,4,7	109	1,3,4,6,7	139	1,2,4,8	169	1,4,6,8	199	1,2,3,7,8	229	1,3,6,7,8
20	3,5	50	2,5,6	80	5,7	110	2,3,4,6,7	140	3,4,8	170	2,4,6,8	200	4,7,8	230	2,3,6,7,8
21	1,3,5	51	1,2,5,6	81	1,5,7	111	1,2,3,4,6,7	141	1,3,4,8	171	1,2,4,6,8	201	1,4,7,8	231	1,2,3,6,7,8
22	2,3,5	52	3,5,6	82	2,5,7	112	5,6,7	142	2,3,4,8	172	3,4,6,8	202	2,4,7,8	232	4,6,7,8
23	1,2,3,5	53	1,3,5,6	83	1,2,5,7	113	1,5,6,7	143	1,2,3,4,8	173	1,3,4,6,8	203	1,2,4,7,8	233	1,4,6,7,8
24	4,5	54	2,3,5,6	84	3,5,7	114	2,5,6,7	144	5,8	174	2,3,4,6,8	204	3,4,7,8	234	2,4,6,7,8
25	1,4,5	55	1,2,3,5,6	85	1,3,5,7	115	1,2,5,6,7	145	1,5,8	175	1,2,3,4,6,8	205	1,3,4,7,8	235	1,2,4,6,7,8
26	2,4,5	56	4,5,6	86	2,3,5,7	116	3,5,6,7	146	2,5,8	176	5,6,8	206	2,3,4,7,8	236	3,4,6,7,8
27	1,2,4,5	57	1,4,5,6	87	1,2,3,5,7	117	1,3,5,6,7	147	1,2,5,8	177	1,5,6,8	207	1,2,3,4,7,8	237	1,3,4,6,7,8
28	3,4,5	58	2,4,5,6	88	4,5,7	118	2,3,5,6,7	148	3,5,8	178	2,5,6,8	208	5,7,8	238	2,3,4,6,7,8
29	1,3,4,5	59	1,2,4,5,6	89	1,4,5,7	119	1,2,3,5,6,7	149	1,3,5,8	179	1,2,5,6,8	209	1,5,7,8	239	1,2,3,4,6,7,8
30	2,3,4,5	60	3,4,5,6	90	2,4,5,7	120	4,5,6,7	150	2,3,5,8	180	3,5,6,8	210	2,5,7,8	*240	5,6,7,8

*HINWEIS: Teilnehmercode 240 ist für die Pförtnerzentrale reserviert

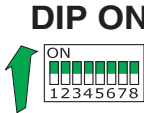
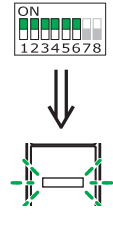
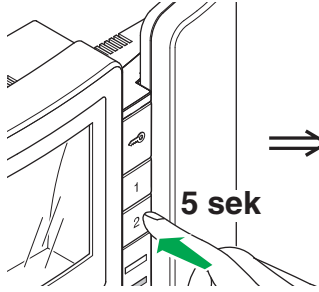
Reset de Programmierung

! 1)	! 2)						3)	4)
S1	DIP 1	DIP 2	DIP 3	DIP 4	DIP 5	DIP 6	S2	S1/S2/LED1
 <p>DIP ON</p>	1	1	1	1	1	1		 <p>5 sek</p>  <p>2 sek</p>  <p>Die Einstellung von S2, S1 notieren und nach Abschluss der Programmierung wieder herstellen.</p>
<p>Werkseitige Voreinstellungen:</p> <ul style="list-style-type: none"> • Tastenfunktionen abhängig von der Kombination DIP 1-2-3-4 von S2; • Keine Intercom-Adresse; • Keine Funktion Bereich und niedrigste/höchste Adressen; • Reset der Ruftöne; • Eingang IN 1 ⇒ LED (Default). 								

DE

Die Arbeitsschritte 1 bis 4 ausführen											
Programmierung range/Ruftöne	! 1)		! 2)						3)		4)
	S1		DIP 1	DIP 2	DIP 3	DIP 4	DIP 5	DIP 6	S2	S1/S2/LED1	
Niedrigste Adresse Bereich	eingabe des Codes, TAB. C seite 77		0	0	0	0	1	0			Die Einstellung von S2 , S1 notieren und nach Abschluss der Programmierung wieder herstellen
Höchste Adresse Bereich											
Aktivierung Bereich											2 sek
Deaktivierung Bereich											
Wahl Mehrklang-Läutwerk			0	1	0	1	1	0			S2
Wahl Töne-Läutwerk (Default)											

Die Arbeitsschritte 1 bis 4 ausführen									
1)	2)					3)		4)	
S1	DIP 1	DIP 2	DIP 3	DIP 4	DIP 5	DIP 6	S2	S1/S2/LED1	
Programmierung Eingang IN1 für Meldung LED/Alarm/Türöffner/Relais									
Eingang IN 1 ⇒ LED (Default), siehe auf S. 124	0	0	0	1	1	0			
Eingang IN 1 ⇒ ALARM, siehe auf S. 124									
Eingang IN 1 ⇒ TURÖFFNERTASTE, siehe auf S. 124									
Eingang IN 1 ⇒ CODIERTE RELAISSTEUERUNG, siehe auf S. 124	eingabe des Codes, TAB. C seite 77								
Eingang IN 1 ⇒ ALLGEMEINER AKTIVIERER, siehe auf S. 124	DIP ON								

Direkte Programmierung des Internrufs

Ermöglicht die Programmierung der Interngespräche direkt an den Innensprechstellen.

✓ Erfordert 2 Installateure.

Phase 1: Programmierung aufrufen

Installateur 1 und Installateur 2 führen an 2 Innensprechstellen folgende Arbeitsschritte aus:

1. Die DIP-Schalter 1-2-3-4 von S2 auf die Kombination 1111 stellen.
2. Hörer abheben.
3. Die Tasten 1 und 2 drei Sekunden lang drücken.
 - » Die Innensprechstelle gibt einen Signalton ab.
 - » Die (grüne) LED blinkt.
 - » Die Innensprechstelle aktiviert eine Sprechverbindung.
 - » Hiernach besteht eine Sprechverbindung zwischen den 2 Installateuren.

Phase 2: Programmierung des Interngesprächs

Installateur 1:

- ▶ Drückt die Taste, die darauf programmiert werden soll, Installateur 2 zu rufen (z.B. 2).
- » Die Innensprechstelle von Installateur 1 gibt einen Bestätigungston ab.

Installateur 2:

- ▶ Drückt die Taste, die darauf programmiert werden soll, Installateur 1 zu rufen (z.B. 1).
- » Die Innensprechstelle von Installateur 2 gibt einen Bestätigungston ab.

Installateur 1/Installateur 2:

- ▶ Legen Sie den Hörer.
- » Die Innensprechstelle gibt einen Signalton ab.
- » Die Programmierung der 2 Innensprechstellen ist hiermit abgeschlossen.

Um eine weitere Innensprechstelle zu programmieren, zu PHASE 3 wechseln.



Phase 3: Programmierung weiterer Innensprechstellen

Installateur 1/Installateur 2:

1. Führt an der neuen Innensprechstelle die Arbeitsschritte der Phase 1 aus, um die Sprechverbindung zu aktivieren.
2. Wiederholt die Arbeitsschritte der Phase 2.

ANM. Falls während der Programmierung ein Anruf eingeht, muss man den Anruf annehmen und die Programmierung anschließend fortsetzen.

Änderung der Monitor-Ruftöne

1. Die Taste  gedrückt halten, bis ein Bestätigungston zu hören ist (der Vorgang ist nur bei Anlage in Standby möglich; andernfalls blinkt die Anzeige-LED, um den Benutzer zu informieren).
2. Taste  drücken und wieder loslassen:
 - 1 Mal (es wird ein Bestätigungston ausgegeben), um den Ruftön für Anrufe von einer Außensprechstelle zu ändern.
 - 2 Mal (es werden zwei Bestätigungstöne ausgegeben), um den Ruftön für Anrufe von der Pförtnerzentrale zu ändern.
 - 3 Mal (es werden 3 Bestätigungstöne ausgegeben), um den um den Ruftön für Interngespräche von einer Innensprechstelle zu ändern.
 - 4 Mal (es werden 4 Bestätigungstöne ausgegeben), um den Ruftön des Etagenrufs zu ändern.
 Durch erneutes Drücken der Taste  wird die oben beschriebene Sequenz wiederholt.
3. Die Taste 1 drücken und loslassen, um die verfügbaren Ruftöne nacheinander zu durchlaufen.
4. Die Taste 2 drücken, um um die Wahl des zuletzt gehörten Ruftons zu bestätigen und die Betriebsart zur Ruftönänderung des Monitors (jederzeit) zu verlassen. Bei Beenden der Betriebsart zur Ruftönänderung des Monitors wird ein Bestätigungston ausgegeben.

Besondere Programmierungen Art. 4882

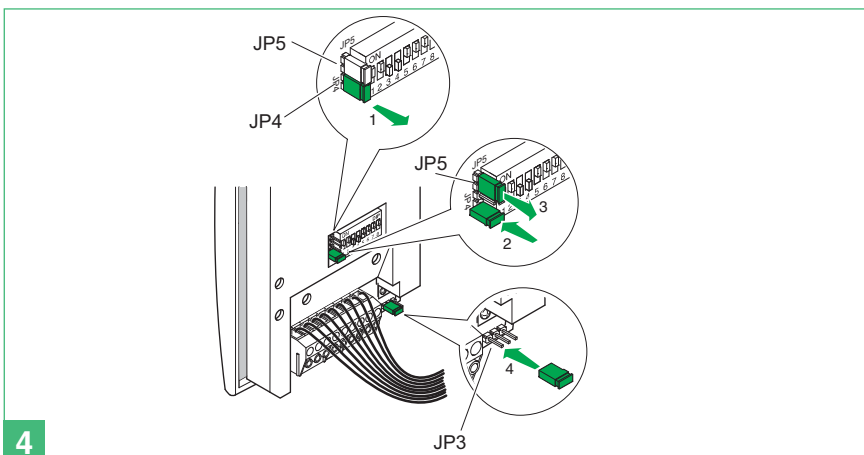
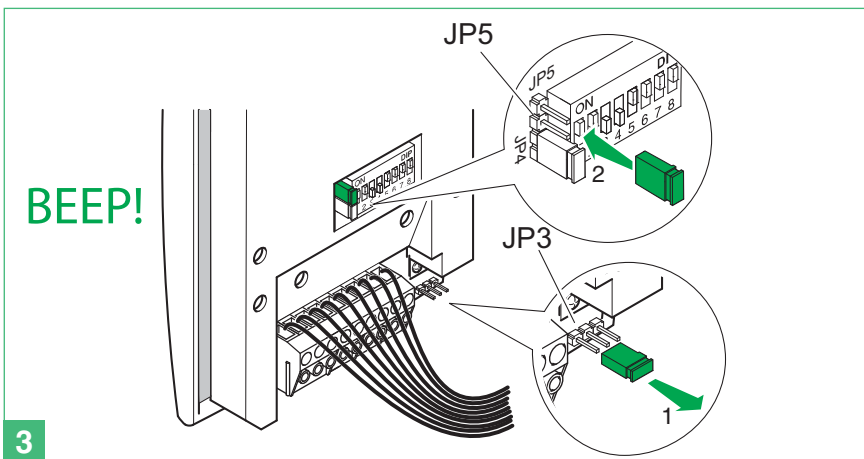
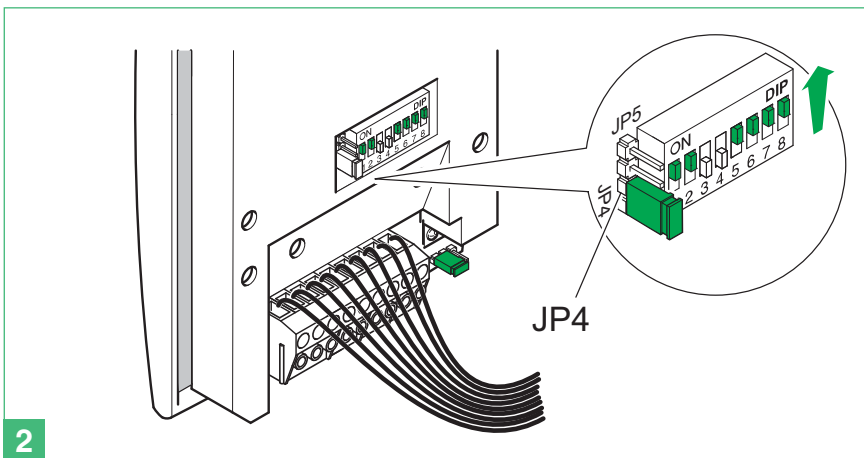
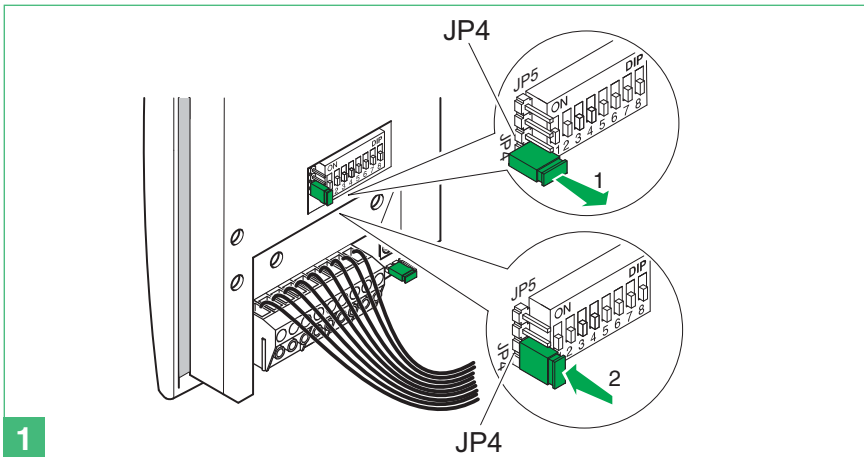

Code	Dip switch ON	
Türschloss		
245	1,3,5,6,7,8	Betätigungsdauer des Türöffners: 2 Sek. + Signalton deaktiviert (Voreinstellung)
246	2,3,5,6,7,8	Türöffner-Bestätigungston: aktiv
247	1,2,3,5,6,7,8	Betätigungsdauer des Türöffners: 8 Sek.
252	3,4,5,6,7,8	Türöffner immer aktiviert (Voreinstellung)
253	1,3,4,5,6,7,8	Türöffner nur für angerufenen Teilnehmer aktiv

Anlagenfunktionen		
243	1,2,5,6,7,8	Wartezeit Reset: 10 Sek. (Voreinstellung)
244	3,5,6,7,8	Wartezeit Reset: 1 Sek.
248	4,5,6,7,8	Rufübermittlung: Einzelruf (Voreinstellung)
249	1,4,5,6,7,8	Rufübermittlung: Dreifachruf

254	2,3,4,5,6,7,8	Reset auf Voreinstellung
-----	---------------	---------------------------------

Art. 4882 können mit Sonderprogrammierungen auf bestimmte Anlagenerfordernisse abgestimmt werden.

1. Zum Aufruf des Programmiermodus den Stecker von JP4 (Abb. 1) senkrecht einstecken.
2. Mit den Dipschaltern die Nummer der Funktion eingeben, die programmiert werden soll (Abb. 2), siehe hierzu die Tabelle auf Seite 81.
3. Zur Bestätigung der eingestellten Funktion den Stecker von JP3 in Stellung JP5 umstecken (Abb. 3) und warten, bis ein Bestätigungston ausgegeben wird.
4. Um eine weitere Sonderprogrammierung vorzunehmen, den Stecker von JP5 abziehen und erneut die Arbeitsschritte unter Punkt 2 und 3 ausführen.
5. Die Stecker anschließend wieder in ihre Ausgangsstellung bringen (Abb. 4): Stecker JP4 in die waagerechte Stellung und den zweiten Stecker JP5 in Stellung JP3.

Advertencias

- La instalación se ha de efectuar en conformidad con las normas vigentes, siguiendo atentamente las instrucciones suministradas por el fabricante.
- Todos los aparatos deben destinarse exclusivamente al uso para el cual han sido contruidos. **Comelit Group S.p.A.** declina toda responsabilidad por el uso impropio de los aparatos, por cambios efectuados por terceros por cualquier motivo o finalidad y por el uso de accesorios y materiales no originales.
- Todos los productos son conformes a los requisitos de las Directivas 2006/95/CE (que sustituye la Directiva 73/23/CEE y sucesivas enmiendas) como demuestra la presencia de la marca **CE** en ellos.
- No poner los cables de la columna montante cerca de los cables de alimentación (230/400V).
- No introducir objetos ni echar líquidos en el interior del dispositivo.
- La instalación, el montaje y el mantenimiento de los aparatos eléctricos deben ser efectuados exclusivamente por electricistas especializados.
- Antes de efectuar cualquier operación de mantenimiento hay que cortar la alimentación.
- Conectar el bastidor de soporte de los módulos a tierra (véase Fig.).
- No mantener presionado el gancho de audio si el micro teléfono está descolgado.
- No instalar la telecámara delante de grandes fuentes luminosas ni en lugares donde la persona captada quede en contraluz. Para evitar este problema, se aconseja instalar la telecámara a una altura de 180 cm (en lugar de la altura habitual de 160-165 cm) y orientar el objetivo hacia abajo ya que esto mejora la calidad de la toma.
- En condiciones de poca luminosidad, las telecámaras con sensor CCD en color ofrecen una menor sensibilidad que las telecámaras en blanco y negro. Por lo tanto, en ambientes poco iluminados, se aconseja instalar una fuente luminosa adicional.

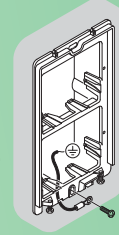

Generalidades	83
Unidad externa	83
Art. 4882	83
Art. 1205/B	83
Instalación de la unidad externa	84
Unidades internas	85
Montaje de la unidad interna Magis	85
Desenganche del monitor	85
Art. 6402E	86
Descripción del monitor	86
Art. 2608	87
Instalación del telefonillo Art. 2608	87
Indicaciones generales de instalación y funcionamiento	88
Tabla de las distancias de funcionamiento	88
Funcionamiento	88
Descripción de las configuraciones y del funcionamiento de los pulsadores	89
Configuración del monitor Art. 6402E y telefonillo Style	89
TAB. A Direcciones de la columna montante	89
Descripción de las funciones de los pulsadores	89
Monitores adicionales, principales o secundarios	90
Configuración predefinida de los pulsadores	90
Advertencias generales para la programación de los pulsadores	90
Programación de los pulsadores para actuador genérico o asignado a una dirección	91
Programación para llamada intercomunicante	91
Programación/borrado de la dirección intercomunicante (solo para intercomunicante selectivo)	91
TAB. B Direcciones intercomunicante selectivo	91
Programación de los pulsadores para llamada intercomunicante	92
Programación de los pulsadores para otras funciones	92
TAB.C Direcciones de la columna montante	93
Reset del la programación	93
Programación range/tonos de llamada	94
Programación de la entrada IN1 para señalización de led/alarma/abrepuertas/actuador	95
Programación directa de la llamada intercomunicante	96
Variación de los tonos de llamada del monitor	96
Programaciones especiales Art. 4882	97
Esquema de conexión	
MSK/012C Esquema básico para kits unifamiliares Art. 8471MC. Puesta en funcionamiento / comprobación de las tensiones con la instalación en reposo.....	114
MSK/017AC Esquema para kits unifamiliares Art. 8471MC ampliados con un segundo Art. 4882	115
MSK/012/AC Esquema para kits unifamiliares con alimentador adicional Art. 1395	116
MSK/015C Uso del módulo telecámara separada Art. 1259C	117
SB2/AAR Conexión del amplificador vídeo Art. 4833C	118
MSK/HCA Adición de un monitor principal en paralelo. Conexión en cascada	118
MSK/IC Adición de un monitor principal en paralelo. Conexión en derivación.....	119
MSK/A20S Conexión en cascada del tercer monitor principal con alimentación local	119
MSK/A23S Conexión en derivación de 2 monitores principales y 2 monitores secundarias con el mismo código de usuario.....	120
MSK/A21S Conexión en cascada de 2 monitores principales y 1 monitor secundario con el mismo código de usuario	120
MSK/AAE Conexión de telefonillos adicionales en derivación desde el monitor	121
MSK/AAD Conexión de telefonillos adicionales en cascada desde el monitor	121
MSK/FC Conexión de telefonillos adicionales en cascada desde el monitor.....	122
SB/X3 Pulsador P1 para varios usos (Art. 2608)	122
SB2V/AAK Conexión de dispositivos de repetición de llamada (Art. 1229 o Art. 1122/A)	123

Variante con conexión para llamada timbre de planta	123
Uso de la entrada IN1 como contacto para señalización de LED/ALARMA/ABREPUERTAS/ACTUADOR. Se activa al cerrar el contacto con CFP2	124
Uso de la entrada IN1 como contacto para señalización de LED/ALARMA/ABREPUERTAS/ACTUADOR. Se activa cuando hay tensión con relación a IN2	124
SB2/AAM2 Pulsador P1 para varios usos.....	125
SMK/EC Conexión del relé actuador Art. 1256	125
GK/AAGC Variante con conexión abrepuertas local temporizado	126
SMK/SNP Variante con cerradura de seguridad y alimentación adicional	126
Uso de la red RC para el filtro de la cerradura en los contactos del relé.....	127

Generalidades

Los kits de vídeo porteros unifamiliares Art. 8471MC se pueden utilizar en edificios civiles o terciarios en los cuales se requiere un control eficaz del acceso y una fácil instalación.

En efecto, sólo se requieren dos conductores entre la unidad externa y los monitores internos para activar el sistema (llamada, audio, vídeo y autoencendido) más dos hilos para alimentar la unidad externa y la electrocerradura y otros dos para la unidad interna de vídeo portero.

Se encuentra disponible una amplia gama de accesorios para resolver fácilmente cualquier exigencia de instalación: además de interesantes accesorios estándar, es posible ampliar la instalación añadiendo monitores, telefonillos o unidades externas.

De esta manera, es posible obtener 2 unidades externas con 4 unidades internas entre telefonillos y monitores de vídeo portero para la configuración unifamiliar.

Mediante las oportunas configuraciones, utilizando monitores de vídeo portero o telefonillos, es posible obtener comunicaciones intercomunicantes unifamiliares (entre usuarios con el mismo código de usuario).

También es posible conectar varios kits a una puerta principal Simplebus y/o a una centralita Art. 1998A.

Unidad externa

Art. 4882

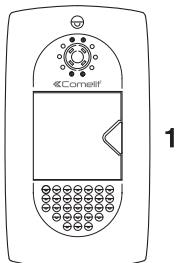

1

Art. 1205/B

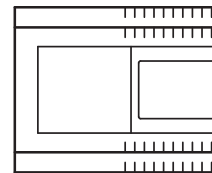

Características técnicas

Conexión al monitor con dos hilos para audio, vídeo, abrepuertas y llamada más dos hilos para la alimentación desde el Art. 1205/B.

Telecámara orientable de alta sensibilidad con sensor CCD 1/3".

Iluminación con leds blancos (6 LED).

Tarjeteros con iluminación con led.

Regulación volumen micrófono y altavoz.

Dimensiones de la caja de empotrar: 176,5x95,5x35 mm.

El pulsador del Art. 4882 se ha configurado en fábrica para llamar a la dirección 1.

Dimensiones de la unidad externa: 176x95x15 mm.

Descripción de la regleta de conexiones

LL conexión al monitor (vídeo, llamada, audio y abrepuertas).

RTE entradas abrepuertas local temporizado.

~ ~ entrada de la unidad externa.

SE. NC. - SE NO. - SE C. conexión a la electrocerradura.

Características técnicas

El transformador prevé dos salidas: una para alimentar la unidad externa y la electrocerradura y otra para alimentar el monitor.

Dimensiones: 105x85x85 mm (6 módulos DIN).

Fusible de protección: 500 mA retardado.

Descripción de la regleta de conexiones

AC230V entrada para tensión de red.

~ ~ salida de CA para unidad externa y cerradura eléctrica.

+ - salida de 20 Vcc de alimentación del monitor.

Instalación de la unidad externa

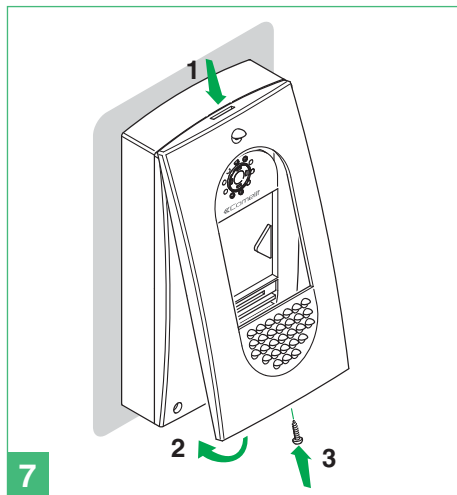
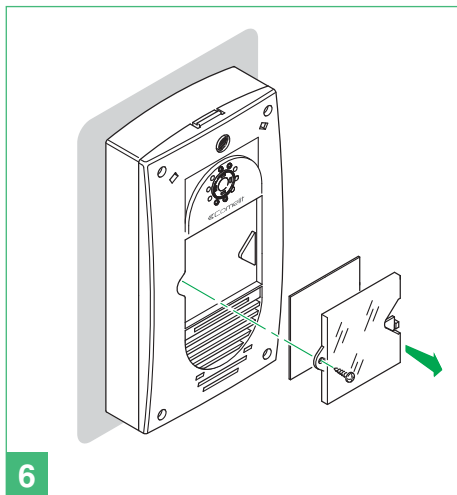
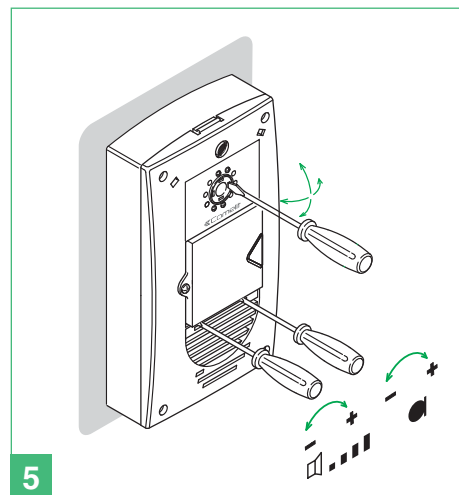
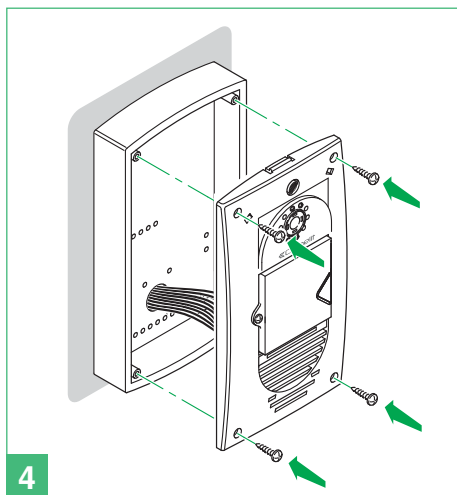
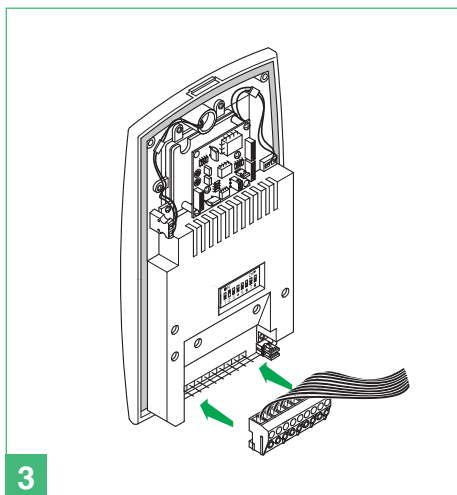
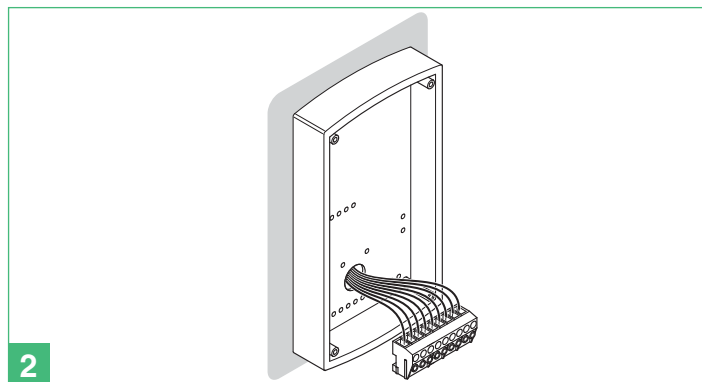
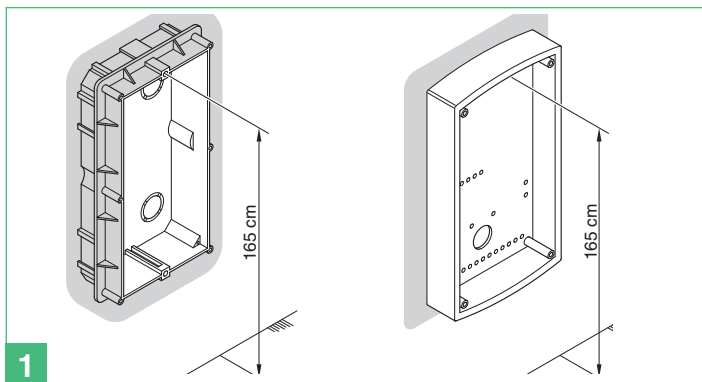
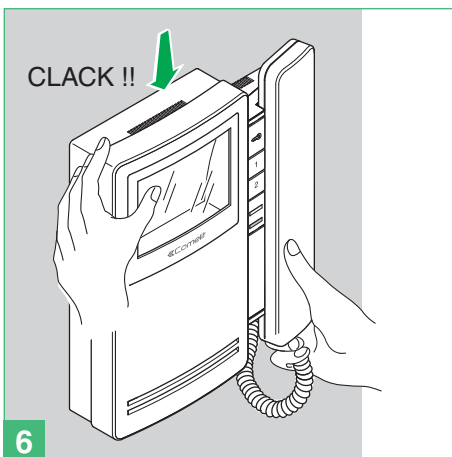
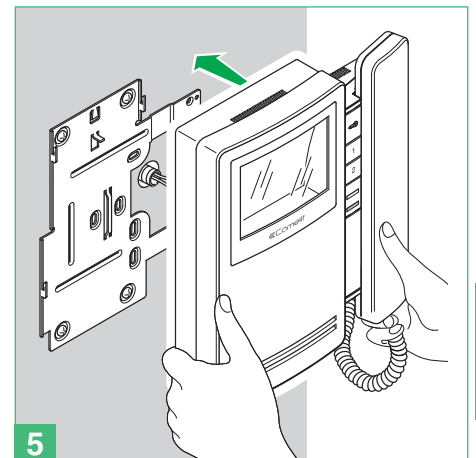
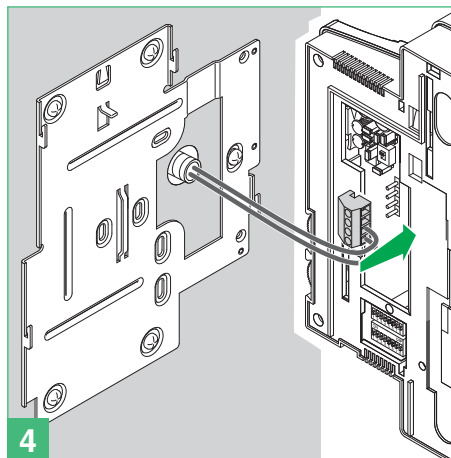
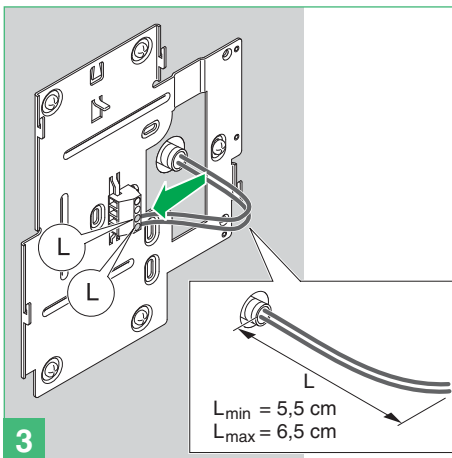
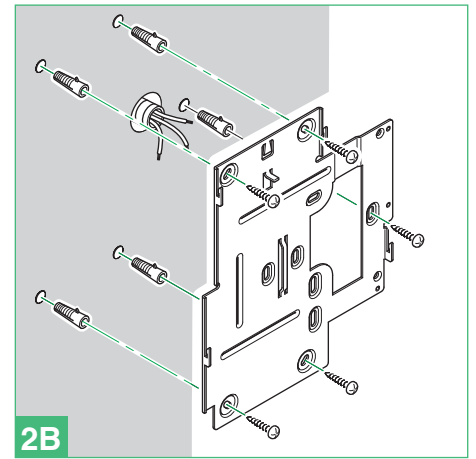
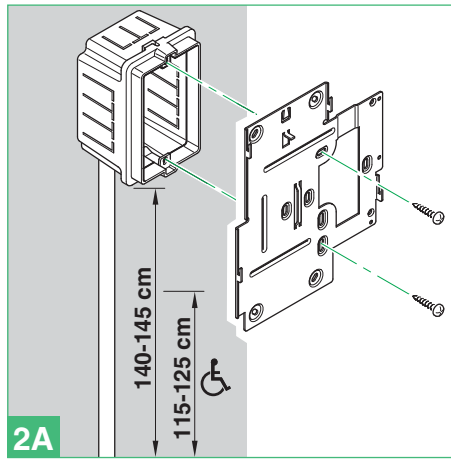
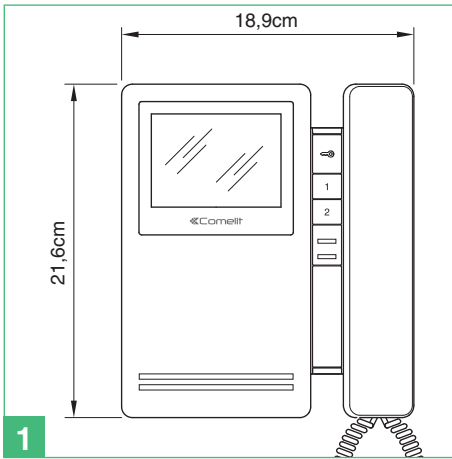

fig. 4 - NOTA: antes de fijar los cuatro tornillos, comprobar que no se desee programar las funciones especiales descritas en la pág. 97.

fig. 5 - NOTA: aflojar ligeramente los cuatro tornillos para desbloquear la telecámara.

Montaje de la unidad interna Magis



Desenganche del monitor

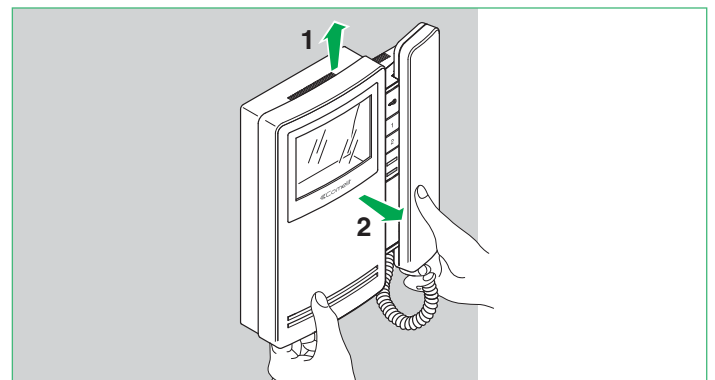

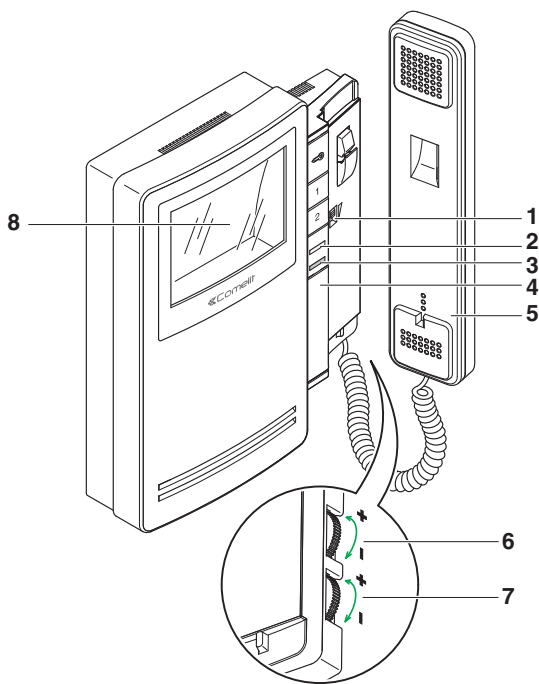

Descripción del monitor:

- 1 Regulación del volumen de llamada / selector de la función Privacidad (por función Privacidad se entiende la exclusión de la llamada desde la unidad externa y desde telefonillos o monitores de vídeo portero intercomunicantes; la activación de la función Privacidad está indicada por el encendido de un indicador rojo al lado del selector).
- 2 Led de señalización de instalación ocupada/función doctor activada/ puerta abierta.
- 3 Indicador rojo - Función privacidad activada.
- 4 Espacio para alojar los pulsadores adicionales con el accesorio Art. 6333, Art. 6434.
- 5 Micro teléfono del monitor (descolgarlo para empezar la comunicación)
- 6 Manípulo de regulación da intensidad da cor.
▶ Girar el mando hacia la izquierda para aumentar el valor.
- 7 Mando de regulación del brillo.
▶ Girar el mando hacia la izquierda para aumentar el valor.
- 8 Pantalla en color de 3,5".

Descripción de los pulsadores:

- ↔ Pulsador abrepuertas.
- 1 Tecla 1 de un actuador genérico (programable).
 - 2 Tecla 2 de autoencendido (programable).

Descripción del monitor

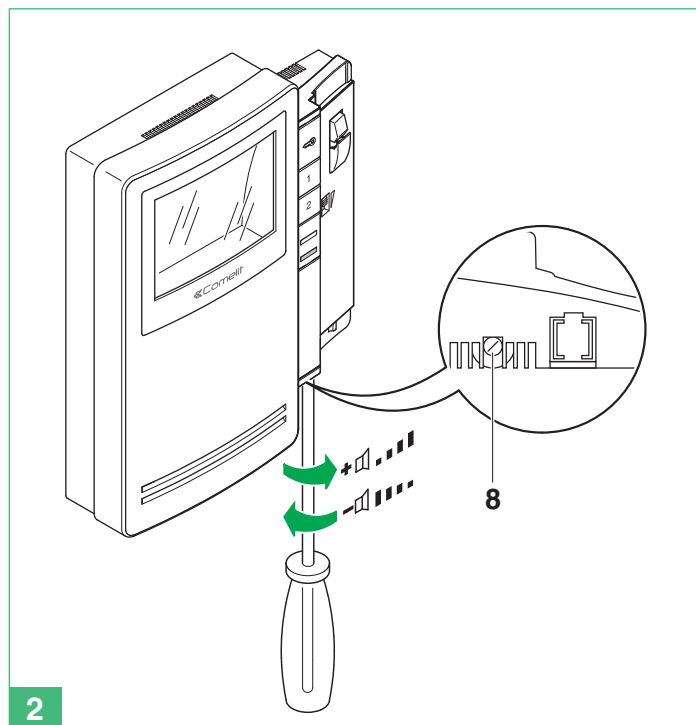
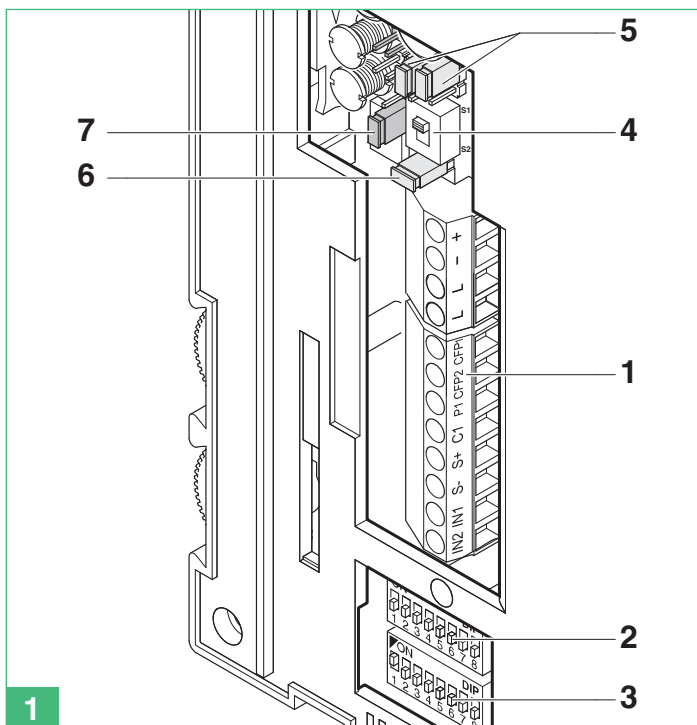

- 1 Regleta de conexiones para la instalación:
+ - Bornes para alimentación.
L L Bornes de conexión a la línea Bus.
CFP1 CFP2 Entrada para llamada timbre de planta.
P1 C1 Bornes pulsador 1 para diferentes servicios.
Para obtener un contacto normalmente abierto (24 V - 100 mA máx.) poner los puentes CV3 y CV4 en posición B.
S+ S- Bornes para el dispositivo de repetición de llamada.
IN1 IN2 Entrada LED (programable).
- 2 S1 Microinterruptores para programar el código de usuario.
- 3 S2 Microinterruptores para programar los pulsadores y las funciones (identificado por un triángulo rojo en un ángulo):
DIP 1-2-3-4 para programar las funciones de los pulsadores.
DIP 5-6 para acceder a la programación.
DIP 7 para controlar la tensión de alimentación (véanse los esquemas y las variantes de la pág. 114), predefinido = OFF.

- DIP 8:**
ON soporte secundario.
OFF soporte principal (predefinido).
- 4 SW3 Selector para modalidad Simplebus 1 (S1 - predefinido) o Simplebus 2 (S2).
 - 5 CV3 CV4 Punte para dejar libre el pulsador 1 (contacto NA 24 V-100 mA máx.).
A Pulsador 1 de un actuador genérico (predefinido) o programable.
B pulsador 1 para diferentes usos.
 - 6 CV5 Punte para el cierre del vídeo.
 - 7 CV6 Selector para uso de la entrada IN 1 (véase pág. 124).
 - 8 Regulación del volumen del altavoz (solo para la configuración del audio intercomunicante).

No se puede utilizar para aprovechar la función intercomunicante. El telefonillo siempre se tiene que montar utilizando el Art. 1214/2C como se ilustra en el esquema de conexión MSK/FC en la pág. 122.

- 1 Indicador de la función Privacidad.
- 2 Selector del tono de llamada/función Privacidad de tres posiciones:
Posición superior: volumen máximo del tono de llamada.
Posición central: volumen medio del tono de llamada.
Posición inferior: activación de la función Privacidad.
(Por función Privacidad se entiende la exclusión de la llamada desde la unidad externa y la centralita; la activación de la función Privacidad está señalada por el encendido de un indicador rojo en la parte superior derecha).
- 3 Trimmer de regulación del volumen del micrófono.
- 4 Microinterruptores para programar el código de usuario.
- 5 Bornes de conexión de la instalación:
L L Conexión a la línea Bus.
CFP CFP Entrada para llamada timbre de planta.
P1 C1 Bornes pulsador P1 para diferentes servicios (contacto normalmente abierto 24 V-100 mA máx.) (quitar CV1 y CV2, véase variante SB/X3 pág. 122).
S+ S- Bornes para dispositivo de repetición de llamada.
- 6 CV1 CV2 Puentes que se han de quitar para obtener un contacto libre de potencial normalmente abierto en el pulsador P1.
- 7A/7B JP1 Puente para seleccionar las funciones Llamada a la centralita (posición C) y actuador genérico (posición A) del pulsador P1.

Descripción de los pulsadores:

- ⏏ Pulsador abrepuertas.
- P1 Pulsador P1 de llamada a la centralita / actuador genérico / pulsador para diferentes funciones presente en la regleta de conexiones (P1 C1).

Limpiar con un paño humedecido en agua. Evitar alcohol y otros productos agresivos.

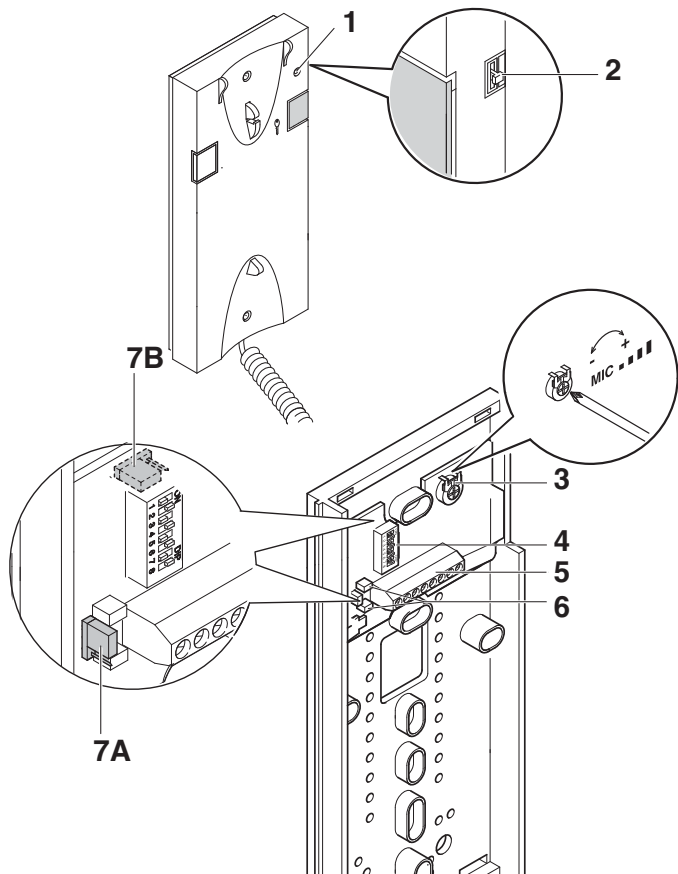

Instalación del telefonillo Art. 2608

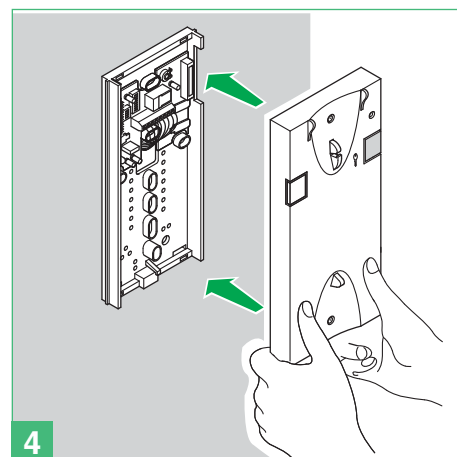
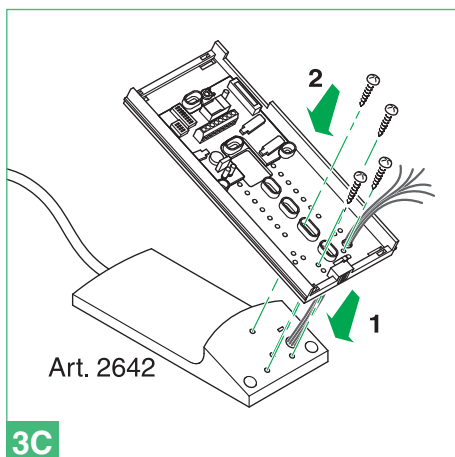
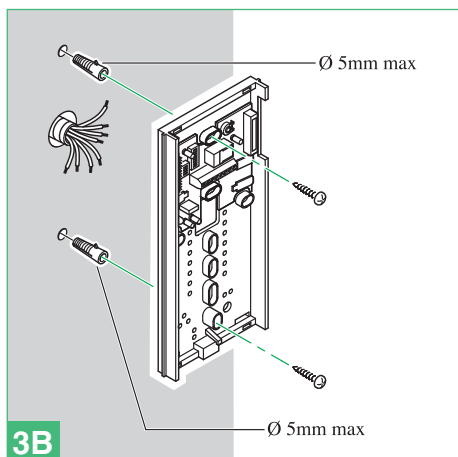
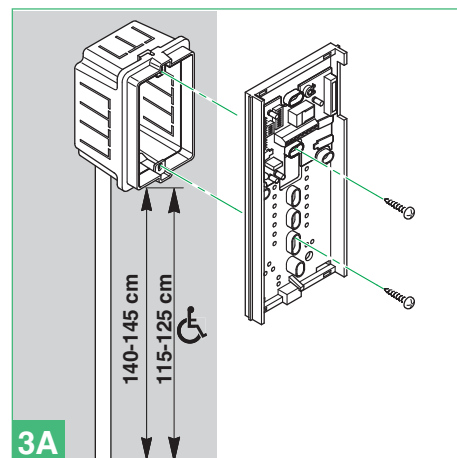
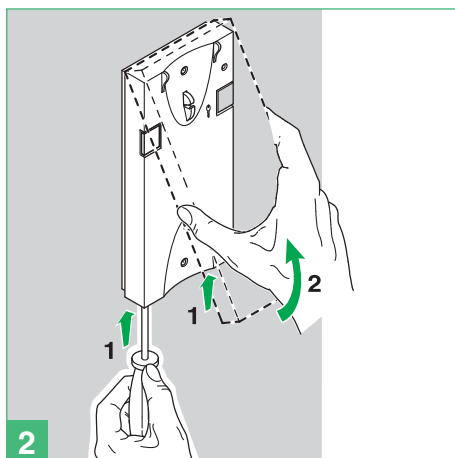
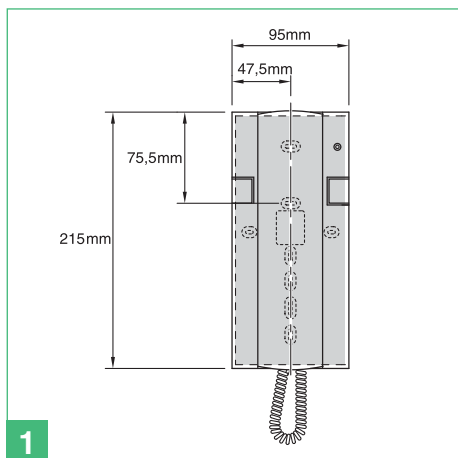

Indicaciones generales de instalación y funcionamiento

La distancia máxima que puede haber entre la unidad externa y el monitor más lejano es de 400 m (con amplificador Art. 4833C).
 Las unidades internas con el mismo código de usuario y los dispositivos de repetición de llamada conectados a dichas unidades internas no pueden sumar más de 4.
 Conectar un único dispositivo de repetición de llamada para cada unidad interna.
 Entre la unidad interna y el dispositivo de repetición de la llamada puede haber 20 m como máximo. Utilizar cable blindado para la conexión y no tender los cables cerca de cargas inductivas pesadas o cables de alimentación (230 V / 400 V).

Tabla de las distancias de funcionamiento

		A/G MAX	B/E MAX	C MAX	D MAX	F MAX	Art. 1216
Comelit Art. 4577 1 mm ² (Ø 1,2 mm AWG 17)		50 m (165 feet)	50 m (165 feet)	200 m (655 feet)	100 m (330 feet)	150 m (495 feet)	
Comelit Art. 4576-4578	0,5 mm ² (Ø 0,8 mm AWG 20) bus		25 m (85 feet)	200 m (655 feet)	100 m (330 feet)	150 m (495 feet)	
	1,5 mm ² (Ø 1,4 mm AWG 15) power	75 m (245 feet)	100 m (330 feet)				
UTP5 cat. 5 0,2 mm ² (Ø 0,5 mm AWG 24)				190 m (625 feet)	60 m (195 feet)	150 m (495 feet)	
0,28 mm ² (Ø 0,6 mm AWG 23)		5 m (15 feet)		190 m (625 feet)	60 m (195 feet)	150 m (495 feet)	
0,5 mm ² (Ø 0,8 mm AWG 20)		25 m (85 feet)	25 m (85 feet)	190 m (625 feet)	60 m (195 feet)	150 m (495 feet)	
1 mm ² (Ø 1,2 mm AWG 17)		50 m (165 feet)	50 m (165 feet)	190 m (625 feet)	60 m (195 feet)	150 m (495 feet)	
1 mm ² (Ø 1,2 mm AWG 17)		50 m (165 feet)	50 m (165 feet)	120 m (395 feet)	40 m (130 feet)	100 m (330 feet)	
1,5 mm ² (Ø 1,4 mm AWG 15)		75 m (245 feet)	100 m (330 feet)	190 m (625 feet)	60 m (195 feet)	150 m (495 feet)	
2,5 mm ² (Ø 1,8 mm AWG 13)		100 m (330 feet)	150 m (495 feet)	190 m (625 feet)	60 m (195 feet)	150 m (495 feet)	

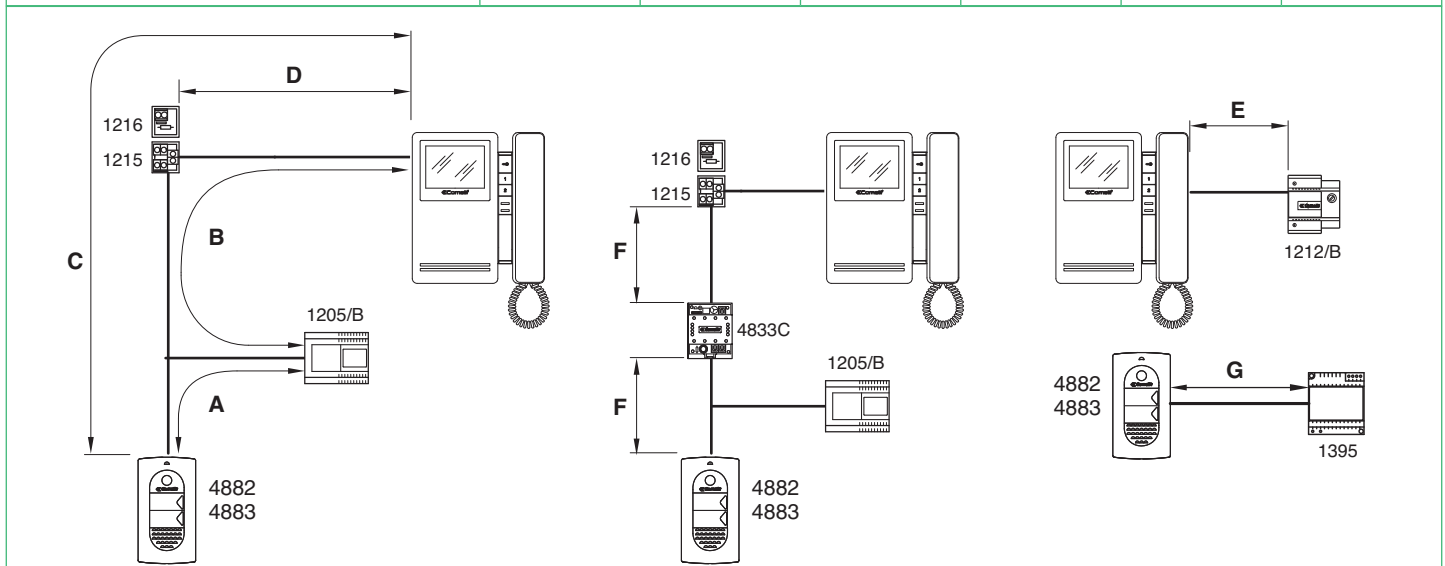

Funcionamiento

! En caso de que se produzca un cortocircuito persistente en la línea de bus, en la unidad externa se oye un tono de señalización intermitente.

El visitante, al pulsar la tecla de llamada, provoca el encendido de los leds de infrarrojos que lo iluminan, el toque del timbre interno (si la función Privacidad no está activada) y la visualización de su imagen en los monitores principales durante 60 segundos.

La conversación entre la unidad externa y la unidad interna puede durar 90" como máximo.

En la unidad externa se obtiene un tono de confirmación de que se ha efectuado la llamada; si, en instalaciones con dos o más entradas, al efectuar una llamada, la unidad externa emite un tono de ocupado en lugar de repetir el timbre, significa que ya existe una comunicación con otra unidad externa.

Para programar direcciones de usuarios diferentes a las programadas en fábrica (1 y 2), véase la pág. 89.

Para las funciones intercomunicantes del sistema Magis Kit, véase página 91.

Descripción de las configuraciones y del funcionamiento de los pulsadores

Configuración del monitor Art. 6402E y telefonillo Style

Posición de los microinterruptores del monitor Art. 6402E

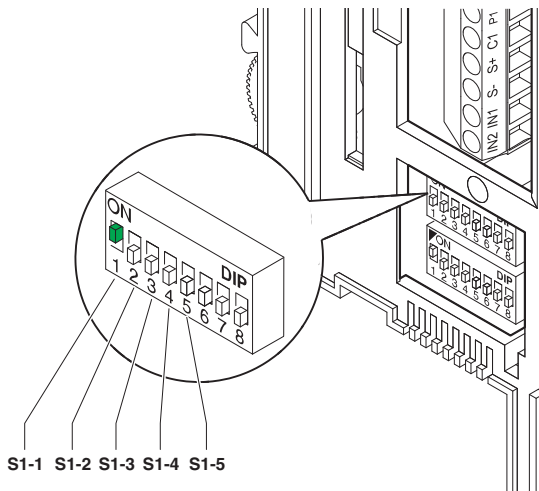

► En los telefonillos Art. 2608, Art. 2610 y Art. 2628, colocar los DIP switch **S1-6**, **S1-7** y **S1-8** en **OFF**

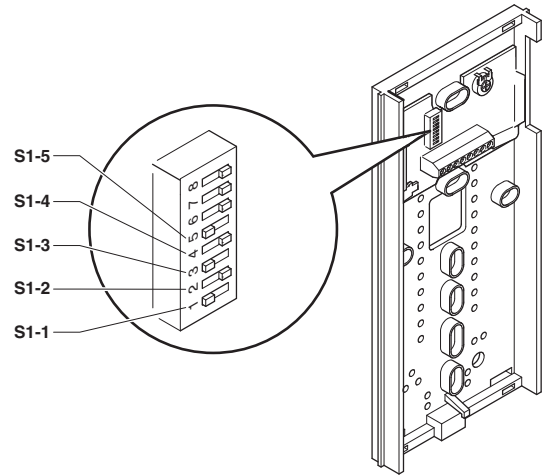

Los valores de los microinterruptores **S1-1**, **S1-2**, **S1-3**, **S1-4** y **S1-5** definen la **dirección de la llamada** del monitor y de los telefonillos como se indica en la tabla siguiente.

TAB. A Direcciones de la columna montante

Código	S1
1	

Descripción de las funciones de los pulsadores

☞ **Abrepuertas:** Al presionar el pulsador abrepuertas, se activa la cerradura conectada a la unidad externa.

Actuador: Si el pulsador se ha configurado como actuador, al presionarlo se activa el relé actuador Art. 1256 que se puede utilizar, por ejemplo, para abrir cancelas o puertas basculantes o para encender el módulo telecámaras cíclicas Art. 1259/C.

Pulsador libre: la indicación de pulsador libre indica la posibilidad de utilizar el pulsador como contacto normalmente abierto en la regleta de conexiones mediante las correspondientes configuraciones como se ilustra en la variante SB2/AAM2 en la página 125.

Autoencendido / solicitud de vídeo

- ✓ Es posible inhabilitar el autoencendido.
- ✓ El autoencendido sólo es posible cuando la instalación está en reposo.
- ✓ El autoencendido sólo se aconseja para instalaciones con una o dos entradas.

Si se presiona la tecla 2, configurada en esta modalidad, en el monitor se visualiza la imagen transmitida desde la unidad externa, incluso si no se ha efectuado ninguna llamada.

En instalaciones dotadas con dos unidades externas es posible visualizar alternativamente la imagen procedente de una u otra unidad externa (función "báscula") presionando repetidamente la tecla 2.

En los monitores secundarios (DIP switch 8 de S2 en ON) esta tecla 2 también sirve para la función Solicitud de vídeo, es decir, permite encender un monitor tras una llamada desde la unidad externa.

Habilitación:

- presionar el pulsador de autoencendido del monitor durante más de 4 s.
- » tono de confirmación.

Inhabilitación:

- presionar el pulsador de autoencendido del monitor durante más de 4 s.
- » 4 tonos de confirmación.

Encendido:

- presionar y soltar de inmediato el pulsador dedicado (pulsador 2 si se mantienen las configuraciones de fábrica).

Llamada a la centralita

Al accionar la tecla configurada en esta modalidad, se envía una llamada a la centralita de consejería de la instalación.

Llamada intercomunicante unifamiliar

Esta función permite enviar una llamada a otros aparatos (monitores de vídeo portero y/o telefonillos) configurados con el mismo código de llamada.

► Al descolgar el micro teléfono, el receptor de la llamada entra en comunicación con el usuario que llama. La comunicación termina al colgar el micro teléfono.

Una llamada intercomunicante no tiene prioridad sobre una conversación o llamada de una unidad externa.

En este caso, durante un intento de llamada intercomunicante, el led parpadea durante algunos segundos para indicar que el sistema está ocupado.

Llamadas desde la unidad externa

En cualquier caso, una llamada desde una unidad externa siempre tiene prioridad con relación a una comunicación intercomunicante (La activación de la comunicación con la unidad externa interrumpe la conversación intercomunicante que se estaba llevando a cabo).

Los usuarios que se encuentran en conversación sentirán en el auricular un tono parecido al de Llamada si esta última está dirigida a ellos o un triple tono de señalización en caso contrario.

► Para responder a la llamada de la unidad externa, sólo hay que descolgar el micro teléfono de alguna unidad libre o colgar y levantar el micro teléfono de una unidad ocupada en una intercomunicación.

Doctor

Esta función permite accionar automáticamente el abrepuertas tras una llamada desde la unidad externa en la dirección de la unidad interna en la que se ha activado la función.

Habilitación / inhabilitación:

- mantener presionado durante 2 s el pulsador que se ha configurado para esta función.

» Con la función activada, el led de señalización permanece encendido.

Monitores adicionales, principales o secundarios

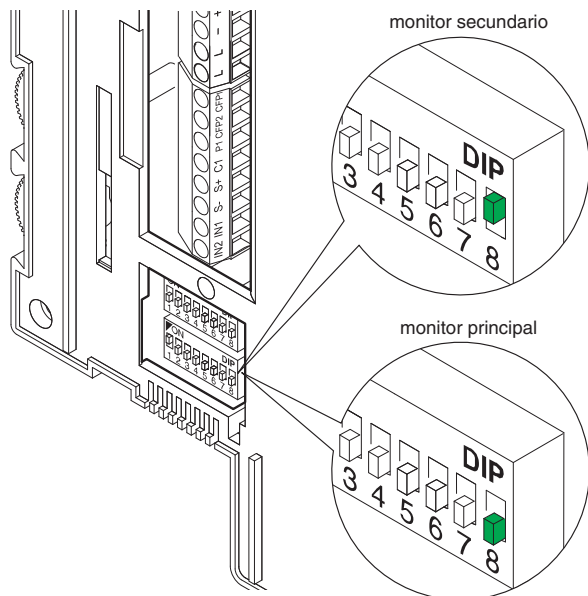

La configuración del DIP switch 8 de S2 define si la placa soporte en cuestión se gestionará como principal (P) o como secundaria (S). La unidad externa puede gestionar hasta un máximo de cuatro monitores de vídeo portero o telefonillos por pulsador de llamada.

Por lo tanto, en la configuración clásica de Magis Kit, se puede disponer de 2 monitores de vídeo portero principales como máximo y de 2 monitores de vídeo portero secundario por pulsador de llamada, alimentados todos ellos por el mismo alimentador **Art. 1205/B**.

Existe la posibilidad de gestionar hasta 3 monitores de vídeo portero principales dentro de una misma unidad familiar (es decir, configurados con el mismo código de usuario). En esta configuración especial, los monitores de vídeo portero principales adicionales se han de alimentar con el correspondiente transformador **Art. 1212/B** (véase variante MSK/HCA, MSK/IC pág. 118, 119).

Cuando se efectúa una llamada desde la unidad externa, el monitor que se enciende es el monitor de vídeo portero principal.

Los otros monitores secundarios de la misma unidad familiar permanecen apagados. Respondiendo a la llamada de la unidad externa desde un monitor de vídeo portero secundario, la imagen se visualiza de inmediato. Luego, el monitor del vídeo portero principal se apaga y la imagen se visualiza en el monitor del vídeo portero secundario desde el cual se ha accionado el pulsador 2 Autoencendido / Solicitud de vídeo.

Para ver la imagen sin activar el audio con la unidad externa, hay que presionar el pulsador 2 - Autoencendido / Solicitud de vídeo.

Configuración predefinida de los pulsadores

DIP S2								con Art. 6433, 6434			
DIP 1	DIP 2	DIP 3	DIP 4	P1	P2	🔑	📞	P3	P4	P5	P6
0	0	0	0	CCS	AI			ACT	D	PAN	K
1	0	0	0	ACT	AI			INT	INTb	D	CCS
0	1	0	0	INT	AI	🔑		INTb	ACT	CCS	CCP
1	1	0	0	ACT	CCS			CCP	PAN	K	D
0	0	1	0	ACT	ACT	ACT		ACT	ACT	ACT	ACT
1	0	1	0	INT	ACT			CCS	CCP	INTb	PAN
0	1	1	0	AI	D			K	CCS	CCP	INTb
1	1	1	0	INTb	INT		📞	AI	INT	PAN	D
0	0	0	1	CCS	PAN			D	AI	INT	INTb
1	0	0	1	K	CCS	🔑		PAN	CCP	AI	INT
0	1	0	1	CCP	K			PAN	ACT	INT	AI
1	1	0	1	PAN	CCP			CCS	K	ACT	D
0	0	1	1	D	INTb			INT	ACT	AI	CCS
1	0	1	1	INT	INT			INT	INT	INT	INT
0	1	1	1	NULL	NULL	NULL	NULL	NULL	NULL	NULL	NULL
1	1	1	1						PROG		

Leyenda

🔑	Abrepuertas	CCS	Llamada a la centralita	INTb	Intercomunicante bifamiliar - sólo para KIT
📞	Audio	K	Llamada al telefonillo del vigilante	NULL	Ninguna función
ACT	Actuador	D	Doctor	PROG	Funciones programadas, véanse págs. 90-91-92-93 Con esta configuración de DIP switches, los pulsadores controlan las funciones programadas; los pulsadores NO programados gestionan las funciones relativas a la línea 0000
AI	Autoencendido	PAN	Pánico		
CCP	Llamada a la centralita principal	INT	Intercomunicante programable general o selectivo - llamada bifamiliar de serie para KIT y Simplebus Top		



Advertencias generales para la programación de los pulsadores

Si la configuración predefinida de los pulsadores (véase tabla de pág. 90) no responde a las necesidades del usuario, es posible configurarlos de otra manera según se describe a continuación.

Al término, poner los DIP switches 1-2-3-4 de S2 en 1111 (configuración PROG en las tablas de las págs. 90-91-92-93). Configurando los DIP switches

de esta manera, los pulsadores gestionan las funciones programadas; los pulsadores NO programados gestionan las funciones relativas a la línea 0000 (véase tabla de pág. 90). Restablecer la configuración del código de usuario en S1, véase tabla A de pág. 89.

Programación de los pulsadores para actuador genérico o asignado a una dirección

DIP S2				con Art. 6433, 6434						DIP S1			
DIP 1	DIP 2	DIP 3	DIP 4	P1	P2			P3	P4	P5	P6	DIRECCIÓN 1 2 3 4 5 6 7 8	
0	0	0	0					ACT					
1	0	0	0	ACT									
0	1	0	0						ACT				
1	1	0	0	ACT									
0	0	1	0	ACT	ACT	ACT		ACT	ACT	ACT	ACT		
1	0	1	0		ACT								
0	1	1	0										
1	1	1	0										
0	0	0	1										
1	0	0	1										
0	1	0	1						ACT				
1	1	0	1							ACT			
0	0	1	1										
1	0	1	1										
0	1	1	1										
1	1	1	1										

Ejemplo:

En el monitor con código de usuario 5 se desea programar P1= actuador genérico y P2= actuador asignado a código 125.

1. Programar los DIP switches 5-6 de S2 en 01.

» *el led (verde) parpadea.*

2. Consultar la tabla de pág. 91 y elegir una combinación en la que aparezca la función actuador (ACT) para los pulsadores que se desea programar.

ES: para P1= actuador genérico, programar los DIP switches 1-2-3-4 de S2 en 1000, 1100 o 0010 (P1=ACT) y los DIP switches de S1 en 11111111. Pasar al punto 3.

ES: para P2= actuador asignado a código 125, programar los DIP switches 1-2-3-4 de S2 en 0010 o 1010 (P2=ACT) y S1 con la dirección 125 según se ilustra en la **tabla C** de pág. 93. Pasar al punto 3.

3. Presionar y soltar el pulsador al que se desea asociar la función.

» *el led (verde) se enciende.*

» *tono de confirmación en el micro teléfono.*

4. Para salir de la programación, programar los DIP switches 5-6 de S2 en 00.

» *el led (verde) se apaga.*

5. Terminada la programación, poner los DIP switches 1-2-3-4 de S2 en 1111. Restablecer la configuración del código de usuario en S1, véase tabla A de pág. 89.

Programación para llamada intercomunicante

Intercomunicante general y selectivo **NO** son compatibles en la misma columna montante.

Programación/borrado de la dirección intercomunicante (solo para intercomunicante selectivo)

S1	DIP S2						S2	3)
	DIP 1	DIP 2	DIP 3	DIP 4	DIP 5	DIP 6		
1)	2)							
Programación; programar código, TABLA B de pág. 91	0	0	0	1	1	1		
Borrado	1	1	1	1	1	1		

Anotar la posición de **S2, S1** y restablecerla una vez efectuada la programación.

TAB. B Direcciones intercomunicante selectivo

Código	Dip switch ON	S1	Código	Dip switch ON	S1	Código	Dip switch ON	S1
1	1		4	4		7	7	
2	2		5	5		8	8	
3	3		6	6				

Es necesario configurar la dirección intercomunicante en todas las unidades internas de la columna montante. Es posible asociar la misma dirección intercomunicante a un máximo de tres unidades internas. Para la llamada de grupo, seleccionar simultáneamente los códigos intercomunicantes deseados (máximo 3).

Programación de los pulsadores para llamada intercomunicante

DIP S2								con Art. 6433, 6434				DIP S1	
DIP 1	DIP 2	DIP 3	DIP 4	P1	P2			P3	P4	P5	P6	DIRECCIÓN 	
0	0	0	0										
1	0	0	0					INT	INTb				
0	1	0	0	INT				INTb					
1	1	0	0										
0	0	1	0										
1	0	1	0	INT						INTb			
0	1	1	0								INTb		
1	1	1	0	INTb	INT				INT				
0	0	0	1							INT	INTb		
1	0	0	1								INT		INT
0	1	0	1							INT			
1	1	0	1										
0	0	1	1		INTb			INT					
1	0	1	1	INT	INT			INT	INT	INT	INT		
0	1	1	1										
1	1	1	1										

Ejemplo 1 - Intercomunicante selectivo

En el monitor con código de usuario 1 y dirección intercomunicante 1 se desea programar P3= intercomunicante selectivo a la dirección 2 y P4= intercomunicante selectivo a la dirección 3.

Ejemplo 2 - Intercomunicante KIT (intercomunicante entre 2 direcciones contiguas en el intervalo 1 a 30 de las cuales la primera impar).

En el monitor con código de usuario 1 se desea programar P3= llamada general interna y P4= intercomunicante bifamiliar a la dirección 2.

1. Programar los DIP switches 5-6 de S2 en 01.
» *el led (verde) parpadea.*
2. Consultar la tabla de pág. 92 y elegir una combinación en la que aparezca la función intercomunicante (INT o INTb) para los pulsadores que se desea programar.

ES1: para P3= intercomunicante selectivo, programar los DIP switches 1-2-3-4 de S2 en 1000, 0011 o 1011 (P3=INT) y S1 con la dirección 2 según se ilustra en la **tabla B** de pág. 91, pasar al punto 3.

ES1: para P4= intercomunicante selectivo, programar los DIP switches 1-2-3-4 de S2 en 1110 o 1011 (P4=INT) y S1 con la dirección 3 según se ilustra en la **tabla B** de pág. 91, pasar al punto 3.

ES2: para P3= llamada general interna y P4= intercomunicante bifamiliar, programar los DIP switches 1-2-3-4 de S2 en 1000 (P3=INT y P4=INTb) y S1 con código de usuario 1 según se ilustra en la **tabla A** de pág. 89, pasar al punto 3.

3. Presionar y soltar el pulsador al que se desea asociar la función.
» *el led (verde) se enciende.*
» *tono de confirmación en el micro teléfono.*
4. Para salir de la programación, programar los DIP switches 5-6 de S2 en 00.
» *el led (verde) se apaga.*
5. Terminada la programación, poner los DIP switches 1-2-3-4 de S2 en 1111. Restablecer la configuración del código de usuario en S1, véase **tabla A** de pág. 89.

Programación de los pulsadores para otras funciones

DIP S2								con Art. 6433, 6434			
DIP 1	DIP 2	DIP 3	DIP 4	P1	P2			P3	P4	P5	P6
0	0	0	0	CCS	AI				D	PAN	K
1	0	0	0		AI					D	CCS
0	1	0	0		AI					CCS	CCP
1	1	0	0		CCS			CCP	PAN	K	D
0	0	1	0								
1	0	1	0					CCS	CCP		PAN
0	1	1	0	AI	D			K	CCS	CCP	PAN
1	1	1	0					AI		PAN	D
0	0	0	1	CCS	PAN			D	AI		
1	0	0	1	K	CCS			PAN	CCP	AI	
0	1	0	1	CCP	K			PAN			AI
1	1	0	1	PAN	CCP			CCS	K		D
0	0	1	1	D						AI	CCS
1	0	1	1								
0	1	1	1	NULL	NULL	NULL	NULL	NULL	NULL	NULL	NULL
1	1	1	1								

Leyenda

	Abrepuertas	CCS	Llamada a la centralita	NULL	Ninguna función
	Audio	K	Llamada al telefonillo del vigilante	PROG	Funciones programadas
AI	Autoencendido	D	Doctor		
CCP	Llamada a la centralita principal	PAN	Pánico		

Ejemplo:

En el monitor con código de usuario 5 se desea programar P5= autoencendido y P6= llamada a la centralita.

1. Programar los DIP switches 5-6 de S2 en 01.
» *el led (verde) parpadea.*
2. Consultar la tabla de pág. 92 y elegir una combinación en la que aparezcan las funciones deseadas/necesarias para los pulsadores que se desea programar.

ES: para P5= autoencendido y P6= llamada a la centralita, programar los DIP switches 1-2-3-4 de S2 en 0011 (P5=AI y P6=CCS).

3. Presionar y soltar el pulsador al que se desea asociar la función.
» *el led (verde) se enciende.*
» *tono de confirmación en el micro teléfono.*
4. Para salir de la programación, programar los DIP switches 5-6 de S2 en 00.
» *el led (verde) se apaga.*
5. Terminada la programación, poner los DIP switches 1-2-3-4 de S2 en 1111.



TAB.C Direcciones de la columna montante



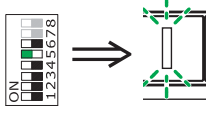

Code	Dip switch ON	Code	Dip switch ON	Code	Dip switch ON	Code	Dip switch ON	Code	Dip switch ON	Code	Dip switch ON	Code	Dip switch ON	Code	Dip switch ON
1	1	31	1,2,3,4,5	61	1,3,4,5,6	91	1,2,4,5,7	121	1,4,5,6,7	151	1,2,3,5,8	181	1,3,5,6,8	211	1,2,5,7,8
2	2	32	6	62	2,3,4,5,6	92	3,4,5,7	122	2,4,5,6,7	152	4,5,8	182	2,3,5,6,8	212	3,5,7,8
3	1,2	33	1,6	63	1,2,3,4,5,6	93	1,3,4,5,7	123	1,2,4,5,6,7	153	1,4,5,8	183	1,2,3,5,6,8	213	1,3,5,7,8
4	3	34	2,6	64	7	94	2,3,4,5,7	124	3,4,5,6,7	154	2,4,5,8	184	4,5,6,8	214	2,3,5,7,8
5	1,3	35	1,2,6	65	1,7	95	1,2,3,4,5,7	125	1,3,4,5,6,7	155	1,2,4,5,8	185	1,4,5,6,8	215	1,2,3,5,7,8
6	2,3	36	3,6	66	2,7	96	6,7	126	2,3,4,5,6,7	156	3,4,5,8	186	2,4,5,6,8	216	4,5,7,8
7	1,2,3	37	1,3,6	67	1,2,7	97	1,6,7	127	1,2,3,4,5,6,7	157	1,3,4,5,8	187	1,2,4,5,6,8	217	1,4,5,7,8
8	4	38	2,3,6	68	3,7	98	2,6,7	128	8	158	2,3,4,5,8	188	3,4,5,6,8	218	2,4,5,7,8
9	1,4	39	1,2,3,6	69	1,3,7	99	1,2,6,7	129	1,8	159	1,2,3,4,5,8	189	1,3,4,5,6,8	219	1,2,4,5,7,8
10	2,4	40	4,6	70	2,3,7	100	3,6,7	130	2,8	160	6,8	190	2,3,4,5,6,8	220	3,4,5,7,8
11	1,2,4	41	1,4,6	71	1,2,3,7	101	1,3,6,7	131	1,2,8	161	1,6,8	191	1,2,3,4,5,6,8	221	1,3,4,5,7,8
12	3,4	42	2,4,6	72	4,7	102	2,3,6,7	132	3,8	162	2,6,8	192	7,8	222	2,3,4,5,7,8
13	1,3,4	43	1,2,4,6	73	1,4,7	103	1,2,3,6,7	133	1,3,8	163	1,2,6,8	193	1,7,8	223	1,2,3,4,5,7,8
14	2,3,4	44	3,4,6	74	2,4,7	104	4,6,7	134	2,3,8	164	3,6,8	194	2,7,8	224	6,7,8
15	1,2,3,4	45	1,3,4,6	75	1,2,4,7	105	1,4,6,7	135	1,2,3,8	165	1,3,6,8	195	1,2,7,8	225	1,6,7,8
16	5	46	2,3,4,6	76	3,4,7	106	2,4,6,7	136	4,8	166	2,3,6,8	196	3,7,8	226	2,6,7,8
17	1,5	47	1,2,3,4,6	77	1,3,4,7	107	1,2,4,6,7	137	1,4,8	167	1,2,3,6,8	197	1,3,7,8	227	1,2,6,7,8
18	2,5	48	5,6	78	2,3,4,7	108	3,4,6,7	138	2,4,8	168	4,6,8	198	2,3,7,8	228	3,6,7,8
19	1,2,5	49	1,5,6	79	1,2,3,4,7	109	1,3,4,6,7	139	1,2,4,8	169	1,4,6,8	199	1,2,3,7,8	229	1,3,6,7,8
20	3,5	50	2,5,6	80	5,7	110	2,3,4,6,7	140	3,4,8	170	2,4,6,8	200	4,7,8	230	2,3,6,7,8
21	1,3,5	51	1,2,5,6	81	1,5,7	111	1,2,3,4,6,7	141	1,3,4,8	171	1,2,4,6,8	201	1,4,7,8	231	1,2,3,6,7,8
22	2,3,5	52	3,5,6	82	2,5,7	112	5,6,7	142	2,3,4,8	172	3,4,6,8	202	2,4,7,8	232	4,6,7,8
23	1,2,3,5	53	1,3,5,6	83	1,2,5,7	113	1,5,6,7	143	1,2,3,4,8	173	1,3,4,6,8	203	1,2,4,7,8	233	1,4,6,7,8
24	4,5	54	2,3,5,6	84	3,5,7	114	2,5,6,7	144	5,8	174	2,3,4,6,8	204	3,4,7,8	234	2,4,6,7,8
25	1,4,5	55	1,2,3,5,6	85	1,3,5,7	115	1,2,5,6,7	145	1,5,8	175	1,2,3,4,6,8	205	1,3,4,7,8	235	1,2,4,6,7,8
26	2,4,5	56	4,5,6	86	2,3,5,7	116	3,5,6,7	146	2,5,8	176	5,6,8	206	2,3,4,7,8	236	3,4,6,7,8
27	1,2,4,5	57	1,4,5,6	87	1,2,3,5,7	117	1,3,5,6,7	147	1,2,5,8	177	1,5,6,8	207	1,2,3,4,7,8	237	1,3,4,6,7,8
28	3,4,5	58	2,4,5,6	88	4,5,7	118	2,3,5,6,7	148	3,5,8	178	2,5,6,8	208	5,7,8	238	2,3,4,6,7,8
29	1,3,4,5	59	1,2,4,5,6	89	1,4,5,7	119	1,2,3,5,6,7	149	1,3,5,8	179	1,2,5,6,8	209	1,5,7,8	239	1,2,3,4,6,7,8
30	2,3,4,5	60	3,4,5,6	90	2,4,5,7	120	4,5,6,7	150	2,3,5,8	180	3,5,6,8	210	2,5,7,8	*240	5,6,7,8

*NOTA: el código 240 está reservado a la centralita de conserjería

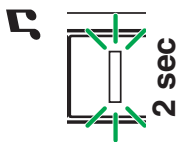
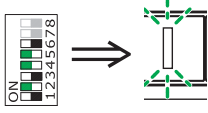
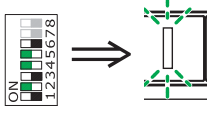
Reset del la programación

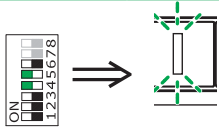
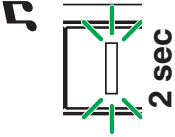
! 1)	! 2)						3)	4)
S1	DIP 1	DIP 2	DIP 3	DIP 4	DIP 5	DIP 6	S2	S1/S2/LED1
<p>DIP ON</p>	1	1	1	1	1	1	<p>5 sec</p>	<p>2 sec</p> <p>! Anotar la posición de S2, S1 y restablecerla una vez efectuada la programación</p>
<p>Configuraciones de fábrica:</p> <ul style="list-style-type: none"> • Funciones de los pulsadores según la combinación de los DIP switches 1-2-3-4 de S2. • Dirección intercomunicante ausente. • Función intervalo y direcciones mín. y máx. ausentes. • Reset tonos de llamada. • Entrada IN 1 ⇒ LED (predefinido). 								

Efectuar las operaciones de 1 a 4												
Programación range/tonos de llamada	! 1)		! 2)							3)		4)
	S1	S2	DIP 1	DIP 2	DIP 3	DIP 4	DIP 5	DIP 6	S2		S1/S2/LED1	
Dirección mínima del intervalo			0	0	0	0	1	0				
Dirección máxima del intervalo	configurar código, TAB. C a de pag. 93		0	0	0	0	0	0				
Habilitación del intervalo												
Inhabilitación del intervalo												
Selección del tono de llamada polifónico			0	1	0	1	1	0				
Selección del tono de llamada estándar (predefinido)			0	1	0	1	1	0				

Efectuar las operaciones de 1 a 4									
! 1)		! 2)					3)		4)
S1		DIP 1	DIP 2	DIP 3	DIP 4	DIP 5	DIP 6	S2	S1/S2/LED1
Programación de la entrada IN1 para señalización de led/alarma/abrepuertas/actuador									
Entrada IN 1 ⇒ LED (predefinido), véase Pág. 124									
Entrada IN 1 ⇒ ALARMA, véase Pág. 124		0	0	0	1	1	0		
Entrada IN 1 ⇒ ABREPUERTAS, véase Pág. 124									 <p>Anotar la posición de S2, S1 y restablecerla una vez efectuada la programación</p>  
Entrada IN 1 ⇒ ACTUADOR ASIGNADO, véase Pág. 124	configurar código, TAB. C a de pág. 93	0	0	1	0	1	0		
Entrada IN 1 ⇒ ACTUADOR GENÉRICO, véase Pág. 124									

Programación directa de la llamada intercomunicante

Permite programar las llamadas intercomunicantes directamente desde las unidades internas.

✓ Necesita 2 operadores.

Fase 1: acceso a la programación

El operador 1 y el operador 2 han de efectuar las siguientes operaciones en 2 unidades internas:

1. Programar los DIP switches 1-2-3-4 de S2 en 1111.

2. Descolgar el auricular.

3. Presionar la tecla 1 y la 2 por 3 s.

» *La unidad interna emite 1 tono.*

» *El led verde parpadea.*

» *La unidad interna entra en comunicación audio.*

» *Entonces, los 2 operadores están en comunicación.*

Fase 2: programación de la llamada intercomunicante

Operador 1:

▶ Presionar el pulsador que se desea programar para llamar al operador 2 (por ejemplo, 2).

» *La unidad interna del operador 1 emite un tono de confirmación.*

Operador 2:

▶ Presionar el pulsador que se desea programar para llamar al operador 1 (por ejemplo, 1).

» *La unidad interna del operador 2 emite un tono de confirmación.*

Operador 1/Operador 2:

▶ Cuelgue el auricular.

» *La unidad interna emite 1 tono.*

» *La programación de las 2 unidades internas ha terminado.*

Para programar otra unidad interna, hay que pasar a la FASE 3.

Fase 3: programación de otras unidades internas



Operador 1/Operador 2:

1. Tras llegar a la nueva unidad, ejecutar la fase 1 para entrar en comunicación.

2. Repetir la fase 2.

NOTA: Si se recibe una llamada durante la programación, es necesario responder y, luego, seguir.

Variación de los tonos de llamada del monitor

1. Mantener presionado el pulsador  hasta que se emita un sonido de confirmación (la operación sólo es posible con la instalación en reposo; si no lo está, el led de señalización parpadea para avisar al usuario).
2. Presionar y soltar el pulsador  :
 - Una vez (se emite un tono de confirmación) para cambiar el tono de llamada desde la unidad externa.
 - Dos veces (se emiten dos tonos de confirmación) para cambiar el tono de llamada desde la centralita.
 - Tres veces (se emiten tres tonos de confirmación) para cambiar el tono de llamada intercomunicante desde unidad interna.
 - Cuatro veces (se emiten cuatro tonos de confirmación) para cambiar el tono de llamada desde el timbre de planta.
 - Si se sigue presionando el pulsador  , se repite la secuencia descrita anteriormente.
3. Presionar y soltar el pulsador 1 para desplazar en secuencia los diferentes tonos de llamada disponibles.
4. Presionar el pulsador 2 para confirmar la elección del último tono de llamada escuchado y para salir en cualquier momento de la modalidad de variación del tono de llamada del monitor. Al salir de la modalidad de variación del tono de llamada del monitor se emite un sonido de confirmación.

Programaciones especiales Art. 4882

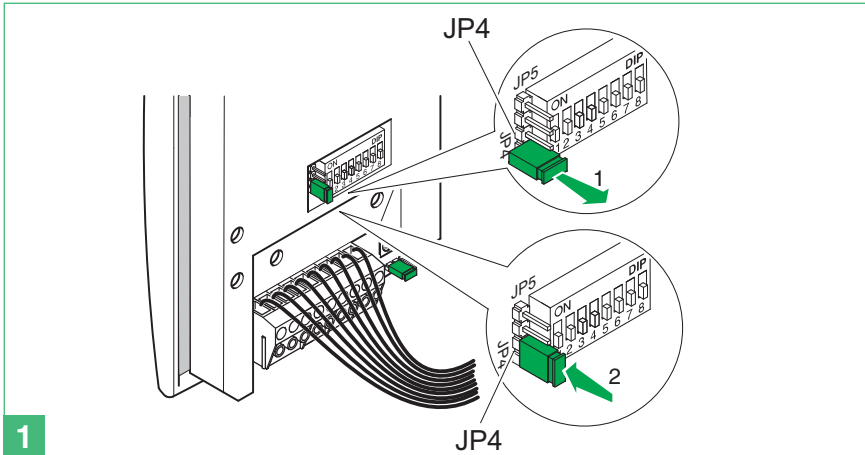

1

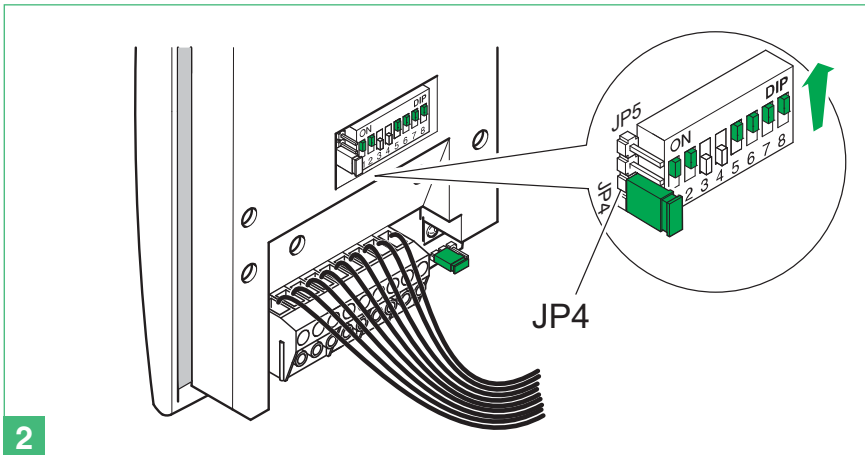

2

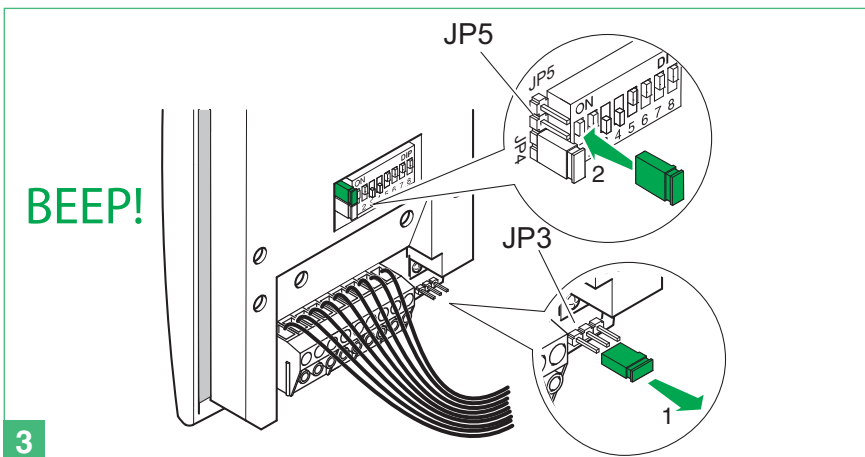

3

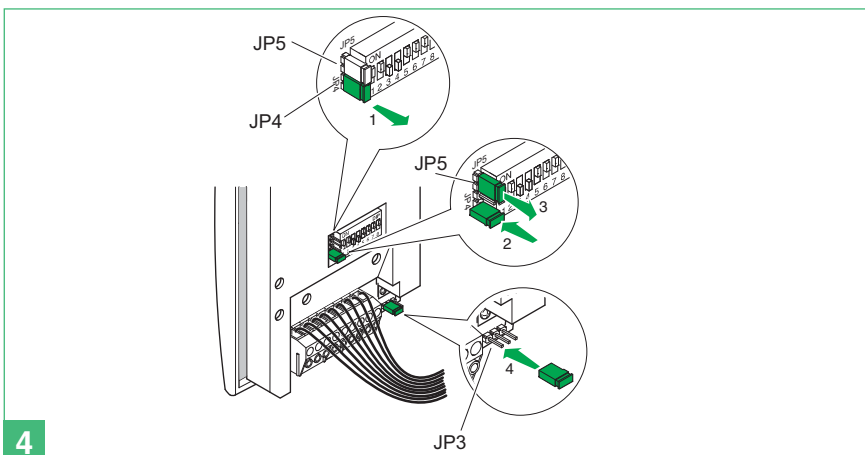

4

Código	Dip switch ON	
Cerradura		
245	1,3,5,6,7,8	Tiempo de la cerradura: 2 s + tono desactivado (predefinido)
246	2,3,5,6,7,8	Tono de confirmación de la cerradura: activado
247	1,2,3,5,6,7,8	Tiempo de la cerradura: 8 s
252	3,4,5,6,7,8	Abrepuertas siempre activo (predefinido)
253	1,3,4,5,6,7,8	Abrepuertas activo sólo para el usuario que ha recibido la llamada

Funciones de la instalación		
243	1,2,5,6,7,8	Tiempo de espera reset: 10 s (predefinido)
244	3,5,6,7,8	Tiempo de espera reset: 1 s
248	4,5,6,7,8	Envío de llamada: una vez (predefinido)
249	1,4,5,6,7,8	Envío de llamada: tres veces
254	2,3,4,5,6,7,8	Restablecimiento predefinido

En los Art. 4882 es posible realizar algunas programaciones especiales de acuerdo con los distintos requisitos de la instalación.

1. Entrar en la modalidad programación colocando el puente JP4 (fig. 1) en vertical.
2. Configurar el código correspondiente a la función que se desea programar (fig. 2) mediante los DIP switches, tal como se ilustra en la tabla de la pág. 97.
3. Confirmar la función configurada desplazando el puente desde JP3 hasta JP5 (fig. 3) y esperar a que se produzca un tono de confirmación.
4. Para efectuar otra programación especial, quitar el puente de JP5 y repetir las operaciones descritas en los puntos 2 y 3.
5. Terminado el procedimiento, volver a colocar los puentes en su posición inicial (fig. 4): el puente JP4 en posición horizontal y el segundo puente JP5 en JP3.

ES

Avisos

- Instalar o equipamento cuidadosamente, seguindo as instruções dadas pelo fabricante e em conformidade com a legislação em vigor.
- Todos os aparelhos devem ser exclusivamente destinados ao uso para o qual foram concebidos. **Comelit Group S.p.A.** declina qualquer responsabilidade pelo uso impróprio do equipamento, quaisquer modificações efectuadas por qualquer motivo sem autorização prévia, como também pelo uso de acessórios e materiais que não tenham sido originariamente fornecidas pela Comelit Group S.p.A.
- Todos os produtos estão em conformidade com os requisitos das directivas 2006/95/CE (que substituem as directivas 73/23/CEE e as alterações subsequentes). A prova é a marca **CE** nos produtos.
- Evitar colocar os fios da coluna na proximidade de cabos de alimentação (230/400 V).
- Não introduzir objectos, nem derramar líquidos no interior do dispositivo.
- As intervenções de instalação, montagem e assistência a aparelhos eléctricos devem ser realizadas exclusivamente por electricistas especializados.
- Cortar a alimentação eléctrica antes de realizar qualquer tipo de manutenção.
- Ligar a moldura à terra (consultar a Fig.)
- Não manter premido o gancho do som com o auscultador levantado.
- A câmara não deve ser instalada à frente de grandes objectos luminosos ou em locais onde a pessoa filmada esteja em contraluz. Para resolver o problema anterior, sugere-se modificar a altura da instalação da câmara, geralmente 160-165 cm, a uma altura de 180 cm e orientar a objectiva para baixo de forma a melhorar a qualidade da captura.
- As câmaras com sensor CCD a cores apresentam, em condições de pouca luminosidade, uma sensibilidade inferior à das câmaras a preto e branco. Sugere-se, portanto, em ambientes pouco iluminados, arranjar uma fonte de iluminação adicional.

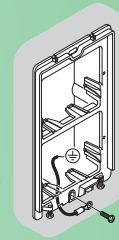

Generalidades	99
Posto externo	99
Art. 4882	99
Art. 1205/B	99
Instalação do posto externo	100
Postos internos	101
Montagem do posto interno Magis	101
Remover o monitor	101
Art. 6402E	102
Descrição do monitor	102
Art. 2608	103
Instalação do telefone intercomunicador Art. 2608	103
Indicações gerais de instalação e funcionamento	104
Tabela de distâncias de funcionamento	104
Funcionamento	104
Descrição das configurações e funcionamento dos botões	105
Configurações do monitor Art. 6402E e telefone intercomunicador Style	105
TAB. A Endereços da coluna	105
Descrição das funções das teclas	105
Monitores suplementares principais ou secundários	106
Configurações dos botões predefinidos	106
Avisos gerais sobre a programação dos botões	106
Programações dos botões para o actuador geral ou com endereço	107
Programação para a chamada de intercomunicação	107
Programação/cancelamento do endereço de intercomunicação (apenas para intercomunicação selectiva)	107
TAB. B Endereços de intercomunicação selectiva	107
Programação dos botões para a chamada de intercomunicação	108
Programação dos botões para outras funções	108
TAB. C Endereços da coluna	109
Reinicialização da programação	109
Programação range/campainhas	110
Programação da entrada IN1 para indicação luz indicadora/alarme/abertura da porta/actuador	111
Programação directa da chamada de intercomunicação	112
Variante das campainhas do monitor	112
Special Programações especiais Art. 4882	113
Esquemas de ligação	
MSK/012C Esquema básico para kits monofamiliares Art. 8471MC. Colocação em funcionamento/controlo das tensões da instalação em pausa...	114
MSK/017AC Esquema para kits monofamiliares Art. 8471MC ampliados com um segundo Art. 4882	115
MSK/012/AC Esquema para kit monofamiliar com alimentador suplementar Art.1395.....	116
MSK/015C Utilização do módulo da câmara separada Art. 1259C.....	117
SB2/AAR Ligação do amplificador vídeo Art. 4833C	118
MSK/HCA Adição de um monitor principal em paralelo. Ligação em cascata	118
MSK/IC Adição de um monitor principal em paralelo. Ligação em derivação	119
MSK/A20S Ligação em cascata do terceiro monitor principal com alimentação local	119
MSK/A23S Ligação em derivação de 2 monitores principais e de 2 monitores secundárias com o mesmo código de utilizador	120
MSK/A21S Ligação em cascata de 2 monitores principais e de 1 monitor secundário com o mesmo código de utilizador	120
MSK/AAE Ligação de telefones intercomunicadores suplementares em derivação do monitor.....	121
MSK/AAD Ligação de telefones intercomunicadores suplementares em cascata do monitor.....	121
MSK/FC Ligação de telefones intercomunicadores suplementares em cascata do monitor.....	122
SB/X3 Utilização do botão P1 para vários usos (Art. 2608)	122
SB2V/AAK Ligação de dispositivos de repetição da chamada (Art. 1229 ou Art. 1122/A)	123
Variante para ligação da campainha externa	123

Utilização da entrada IN1 como contacto para a indicação LUZ INDICADORA/ALARME/ABERTURA DA PORTA/ACTUADOR. Activação perante fecho entre IN1 e CFP2	124
Utilização da entrada IN1 como contacto para a indicação LUZ INDICADORA/ALARME/ABERTURA DA PORTA/ACTUADOR. Activação na presença de tensão comparativamente a IN2	124
SB2/AAM2 Utilização do botão P1 para vários usos	125
SMK/EC Ligação do relé actuador Art. 1256	125
GK/AAGC Variante de ligação da abertura da porta local com tempo programado	126
SMK/SNP Variante com fechadura de segurança e alimentação suplementar	126
Utilização da rede RC para filtrar a fechadura nos contactos do relé	127

Generalidades

Os Kits vídeo-intercomunicadores monofamiliar Art. 8471MC podem ser utilizados em edifícios familiares ou comerciais onde seja necessário um controlo eficiente do acesso através de simples operações de instalação.

De facto, são suficientes 2 condutores entre o posto externo e o(s) monitor(es) interno(s) para activar o sistema (chamada, som, vídeo, acendimento automático), 2 fios para alimentar o posto externo e a fechadura eléctrica e 2 fios para alimentar o posto interno vídeo-intercomunicador.

Adicionalmente, a Comelit disponibiliza uma série de acessórios que resolve facilmente todas as exigências da instalação e para além de acessórios interessantes do tipo padrão, é possível aumentar a instalação adicionando vídeo-intercomunicadores e/ou telefones intercomunicadores e/ou postos externos.

Deste modo, é possível chegar a um máximo de 2 postos externos com 4 postos internos entre telefones intercomunicadores e vídeo-intercomunicadores para a configuração monofamiliar.

Através de configurações apropriadas é possível realizar comunicações de intercomunicação monofamiliares (isto é, entre utilizadores com o mesmo código de utilizador), utilizando quer vídeo-intercomunicadores, quer telefones intercomunicadores.

Podem ser ligados kits adicionais a uma porta principal Simplebus e/ou a uma central Art. 1998A.

Posto externo

Art. 4882

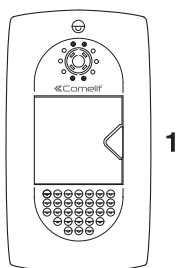

1

Art. 1205/B

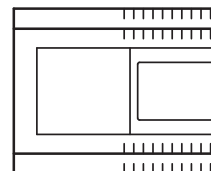

Características técnicas

Ligação ao monitor com 2 fios para áudio, vídeo, abertura da porta e chamada, e 2 fios para alimentação do Art. 1205/B.

Câmara orientável de alta sensibilidade com sensor CCD 1/3".

Iluminação com luzes indicadoras brancas (6 LED).

Cartões porta nomes com iluminação por luz indicadora.

Regulação do volume microfone e altifalante.

Dimensão da caixa de embutir: 176,5x95,5x35 mm.

O botão do Art. 4882 é configurado na fábrica para realizar a chamada ao endereço 1.

Dimensão do posto externo: 176x95x15 mm.

Descrição da bateria de bornes

LL ligação do monitor (vídeo, chamada, áudio, abertura da porta).

~ ~ alimentação do posto externo.

RTE entrada abertura da porta local com temporizador.

SE. NC. - SE NO. - SE C. Ligação da fechadura eléctrica.

Características técnicas

O transformador possui 2 saídas: uma para alimentar o posto externo e a fechadura eléctrica, e outra para alimentar o monitor.

Dimensões: 105x95x65 mm (6 módulos DIN).

Fusível de protecção 500 mA retardado.

Descrição da bateria de bornes

AC230V entrada da tensão de rede.

~ ~ saída AC para posto externo e fechadura eléctrica.

+ - saída de 20V DC para alimentação do monitor.

Instalação do posto externo

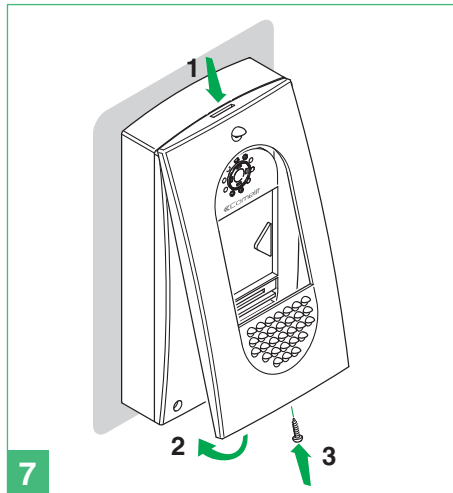
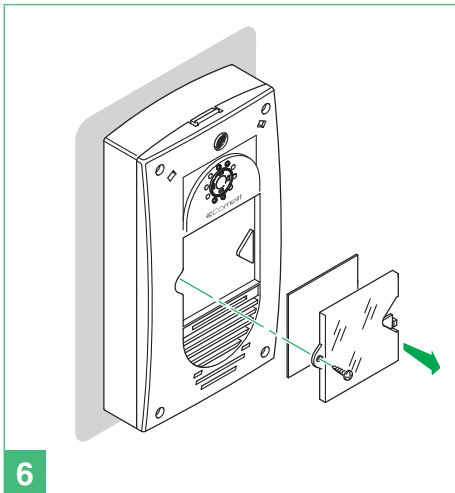
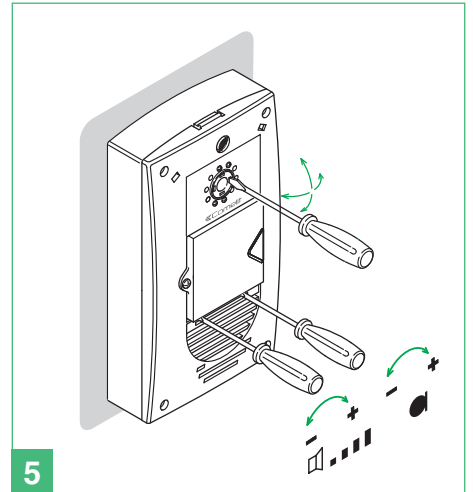
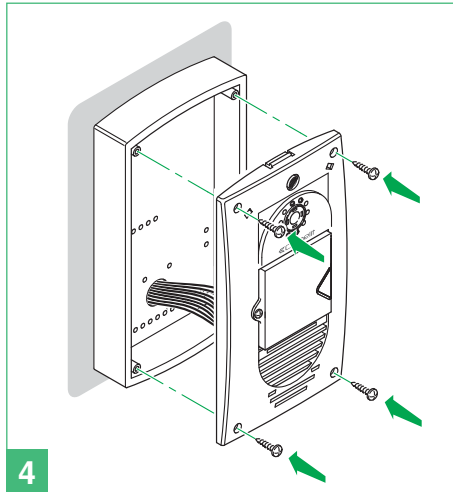
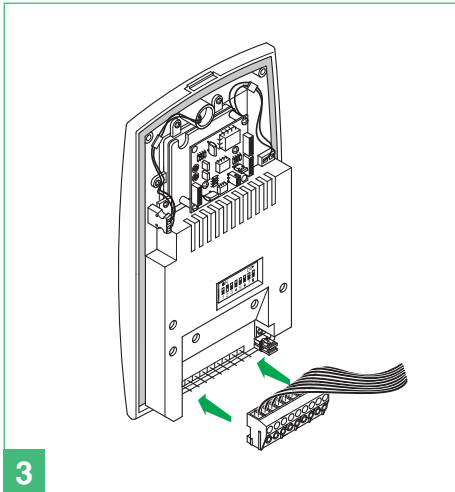
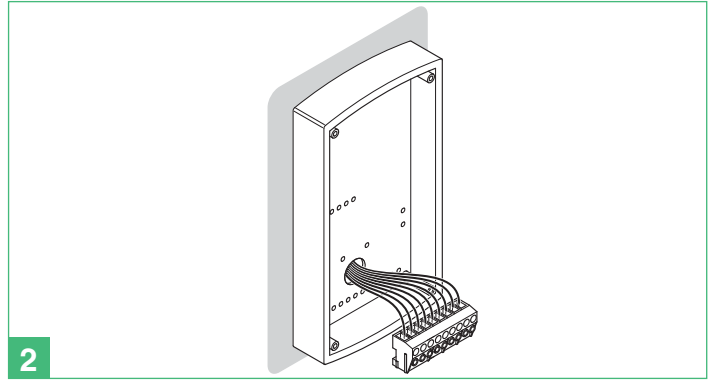
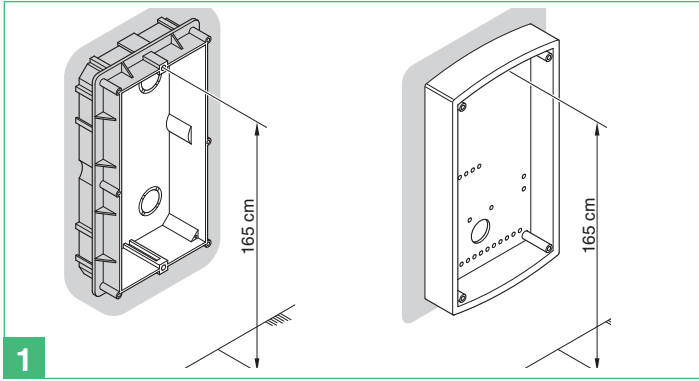
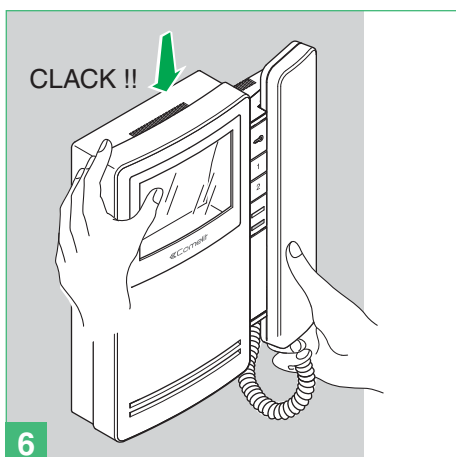
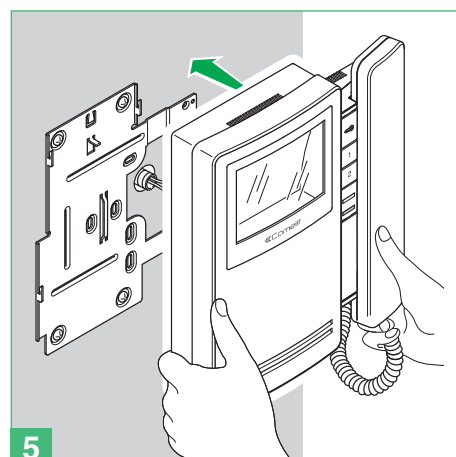
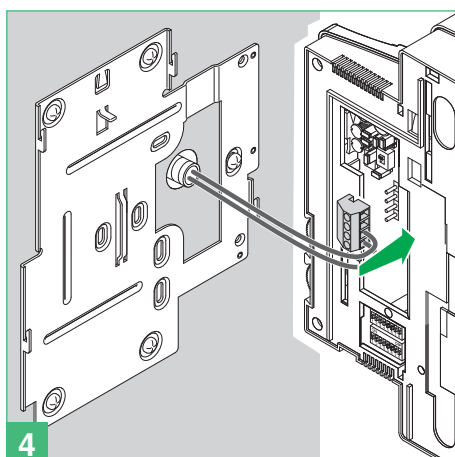
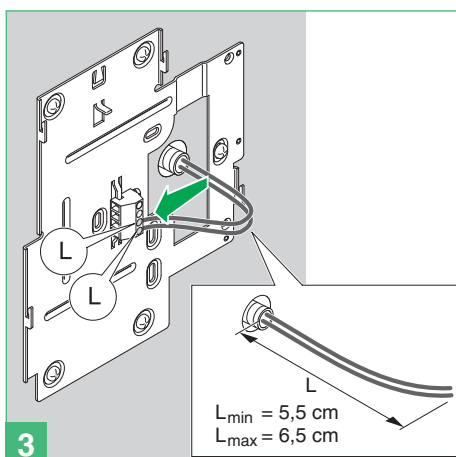
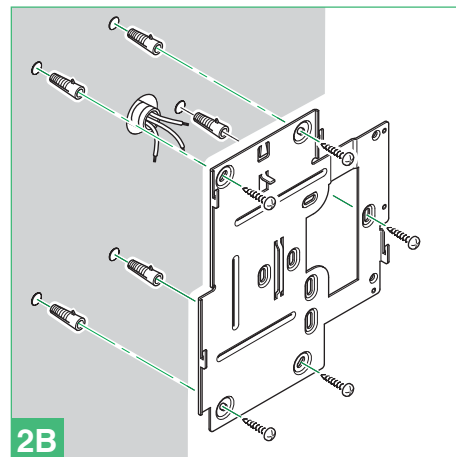
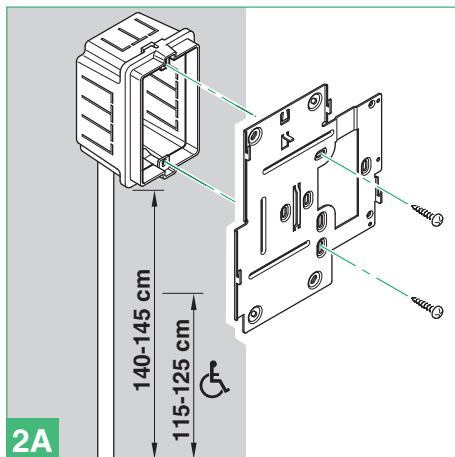
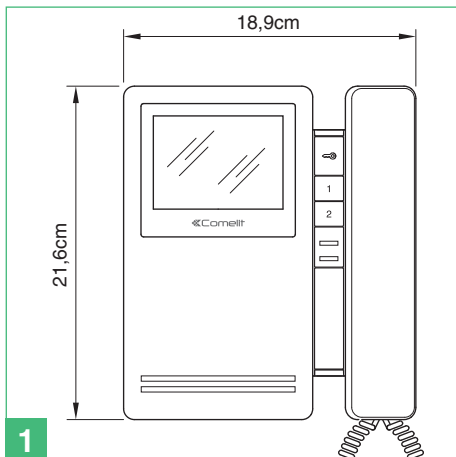

Fig. 4 - NOTA. Antes de fixar os 4 parafusos, controle se pretende efectuar a programação das funções especiais descritas na página 113.

Fig. 5 - NOTA. desaperte ligeiramente os quatro parafusos para desbloquear a direcção da câmara.

PT

Montagem do posto interno Magis



Remover o monitor

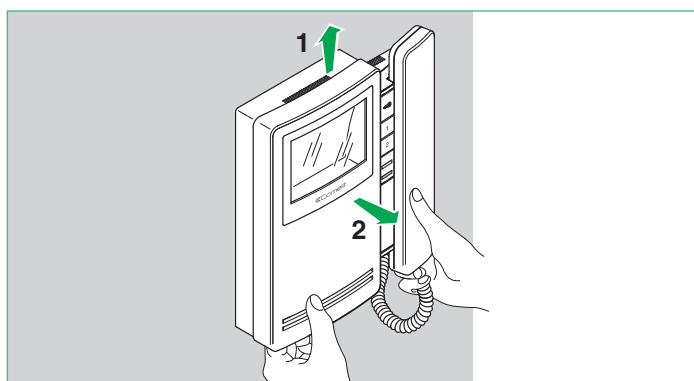

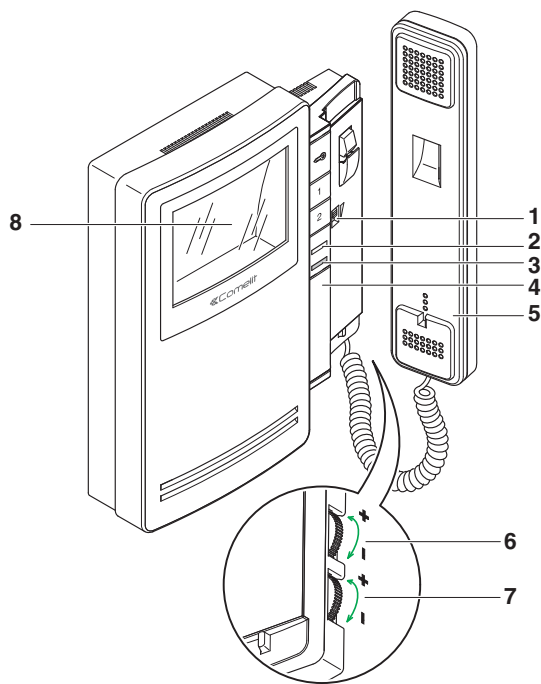

Descrição monitor:

- 1 Regulação do volume de chamada/selectora da função privacidade (por serviço privacidade entende-se a exclusão da chamada do posto exterior e de telefones intercomunicadores e vídeo-intercomunicadores. A activação da função privacidade é evidenciada pelo aparecimento de um indicador vermelho ao lado do selector).
- 2 Luz indicadora de equipamento ocupado/função médico activada/porta aberta.
- 3 Indicador vermelho - privacidade activada.
- 4 Espaço para alojar botões adicionais com o acessório Art. 6333, Art. 6434.
- 5 Auscultador do monitor (levantar o auscultador para iniciar a comunicação).
- 6 Manípulo de regulação da intensidade da cor.
 - ▶ Rodar para a esquerda para aumentar o valor.
- 7 Regulação de luminosidade.
 - ▶ Rodar para a esquerda para aumentar o valor.
- 8 Ecrã a cores 3,5".

Descrição dos botões:

- ☞ Botão de abertura da porta.
- 1 Tecla 1 actuador geral (programável).
- 2 Tecla 2 acendimento automático (programável).

Descrição do monitor

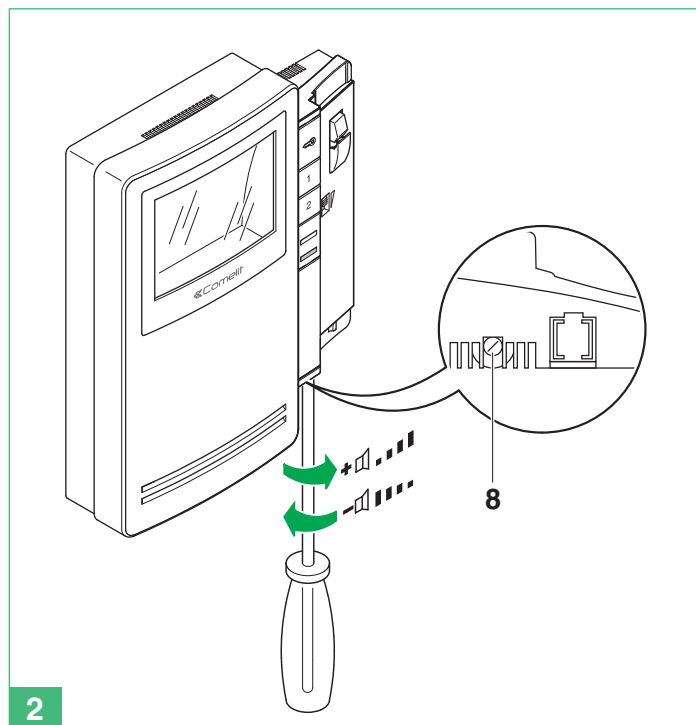
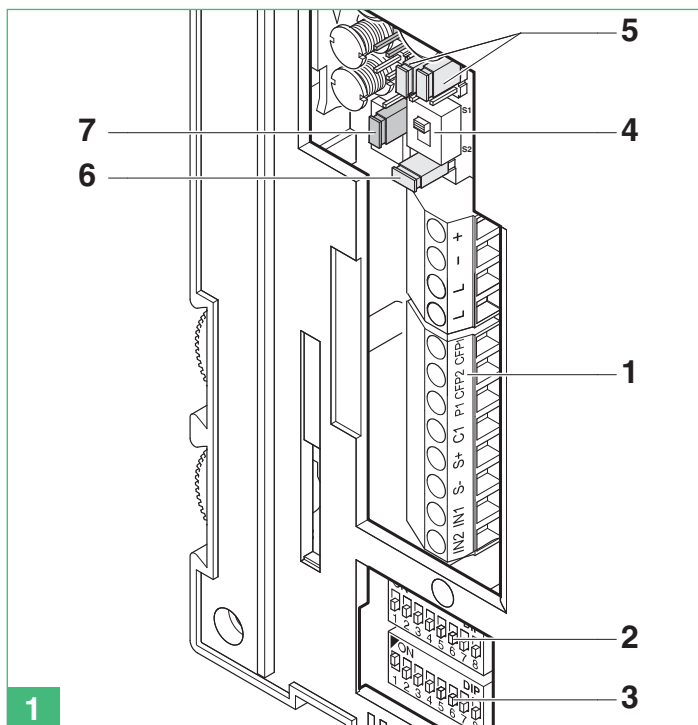

- 1 Bateria de bornes de ligação da instalação:
 + - Bornes para alimentação.
 L L Bornes para ligação à linha bus.
CFP1 CFP2 Entrada de chamada de andar local.
P1 C1 Bornes do botão 1 para vários usos.
Para obter um contacto C.NO. (24 V-100 mA máx.) colocar os comutadores de derivação CV3 e CV4 na posição B.
S+ S- Bornes para dispositivo de repetição de chamada.
IN1 IN2 Entrada para luz indicadora (programável).
- 2 **S1** Microinterruptores para programar o código de utilizador.
- 3 **S2** Microinterruptores para programar os botões e as funções (identificado por um canto vermelho):
DIP 1-2-3-4 para programar as funções dos botões.
DIP 5-6 acesso às programações.
DIP 7 para gerir a alimentação eléctrica (consultar esquemas e variantes da pág. 114) predefinição = **OFF**.

- DIP 8:**
ON suporte secundário.
OFF suporte principal (predefinido).
- 4 **SW3** Selector para o modo Simplebus 1 (S1 - predefinição) ou Simplebus 2 (S2).
- 5 **CV3 CV4** Comutador de derivação para libertar o botão 1 (contacto C.NO. 24 V-100 mA máx.).
A botão 1 Actuador geral (predefinição) ou programável.
B botão 1 para vários usos.
- 6 **CV5** Comutador de derivação fecho vídeo.
- 7 **CV6** selector para utilizar a entrada IN 1 (consultar pág. 124).
- 8 Regulação do volume do altifalante (apenas para a programação do som de intercomunicação).

Não é utilizável como função de intercomunicação.
O telefone intercomunicador deve ser sempre instalado utilizando o Art. 1214/2C como ilustrado no esquema de ligação MSK/FC na pág. 122.

- 1 Indicador da função Privacidade.
- 2 Selector de 3 posições para campanha/serviço privacidade:
Posição alta: campanha no volume máximo.
Posição central: campanha no volume médio.
Posição baixa: activação do serviço privacidade.
(O serviço privacidade significa a exclusão do som de chamada do posto externo e da central; a activação da função de privacidade encontra-se indicada por um indicador vermelho que aparece no canto superior direito).
- 3 Regulação do volume do microfone.
- 4 Microinterruptores para a configuração do código de utilizador.
- 5 Bornes de ligação da instalação:
L L Ligação de linha Bus.
CFP CFP Entrada chamada de andar local.
P1 C1 Bornes do botão P1 para vários usos (contacto C. NO. 24 V-100 mA máx.) (remover CV1 e CV2, consultar a variante SB/X3 na pág. 122).
S+ S- Bornes para o dispositivo de repetição de chamada.
- 6 CV1 CV2 Comutador de derivação a ser removido para ter contacto limpo C. NO. no botão P1.
- 7A/7BJP1 Comutador de derivação para seleccionar a função chamada à central (posição C)/Actuador geral (posição A) do botão P1.

Descrição dos botões:

- ☞ Botão de abertura da porta.
- P1 Botão P1 chamada central/actuador geral/ botão para vários usos disponível na bateria de bornes (P1 C1).

Limpar com um pano humedecido em água. Não utilizar álcool e outros produtos agressivos.

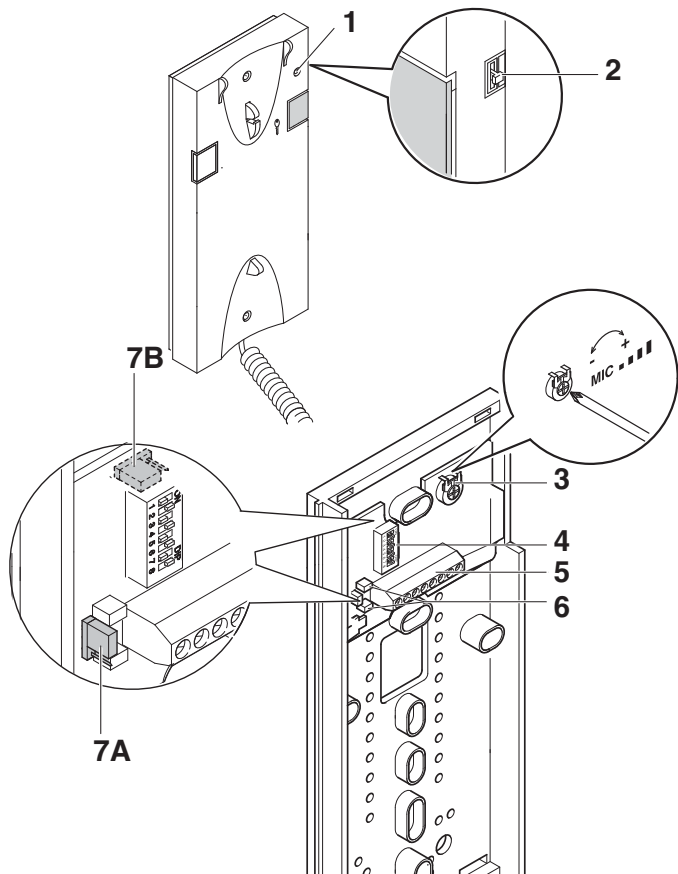

Instalação do telefone intercomunicador Art. 2608

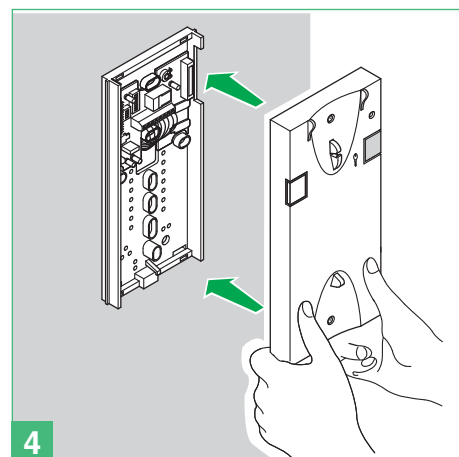
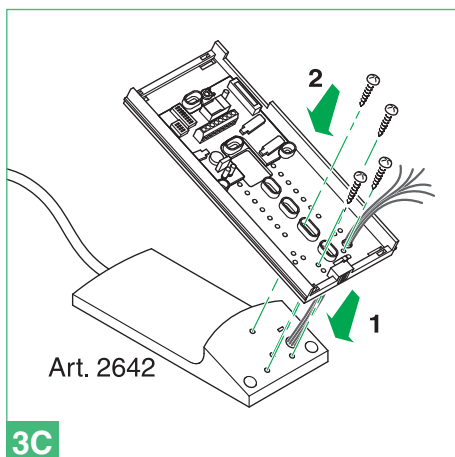
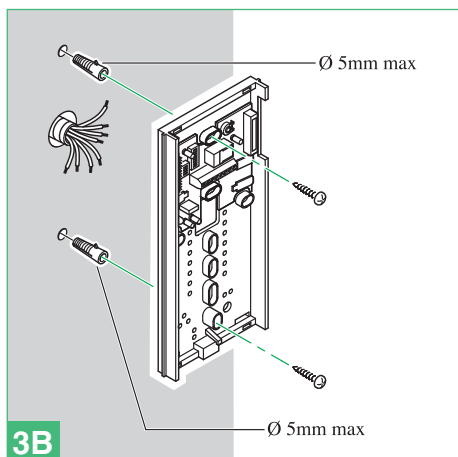
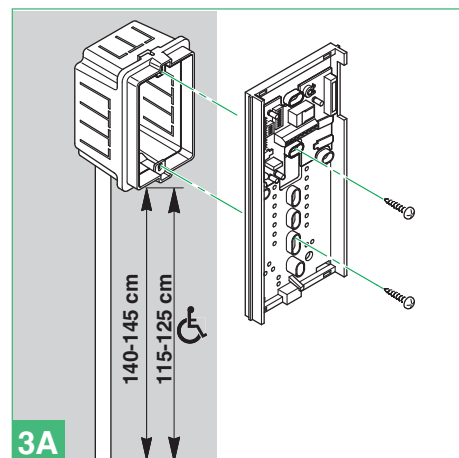
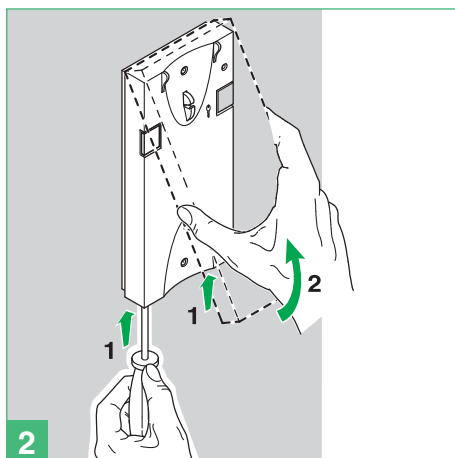
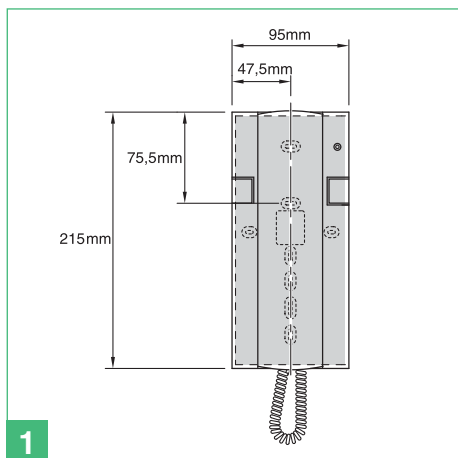

PT

Indicações gerais de instalação e funcionamento

A distância máxima total entre o posto externo e o monitor mais afastado é de 400 m (com amplificador Art. 4833C).

A soma total do número de postos internos com o mesmo código de utilizador e do número de dispositivos de repetição de chamada ligados aos postos internos não pode ser superior a 4.

Ligar apenas um dispositivo de repetição de chamada para cada posto interno.

A distância máxima da ligação entre ponto interno e dispositivo de repetição de chamada de 20 m; usar cabo blindado para a ligação e não passar os cabos na proximidade de cargas indutivas pesadas ou cabos de alimentação (230 V / 400 V).

Tabela de distâncias de funcionamento

		A/G MAX	B/E MAX	C MAX	D MAX	F MAX	Art. 1216
Comelit Art. 4577 1 mm ² (Ø 1,2 mm AWG 17)		50 m (165 feet)	50 m (165 feet)	200 m (655 feet)	100 m (330 feet)	150 m (495 feet)	
Comelit Art. 4576-4578	0,5 mm ² (Ø 0,8 mm AWG 20) bus	25 m (85 feet)	25 m (85 feet)	200 m (655 feet)	100 m (330 feet)	150 m (495 feet)	
	1,5 mm ² (Ø 1,4 mm AWG 15) power	75 m (245 feet)	100 m (330 feet)				
UTP5 cat. 5 0,2 mm ² (Ø 0,5 mm AWG 24)				190 m (625 feet)	60 m (195 feet)	150 m (495 feet)	
0,28 mm ² (Ø 0,6 mm AWG 23)		5 m (15 feet)		190 m (625 feet)	60 m (195 feet)	150 m (495 feet)	
0,5 mm ² (Ø 0,8 mm AWG 20)		25 m (85 feet)	25 m (85 feet)	190 m (625 feet)	60 m (195 feet)	150 m (495 feet)	
1 mm ² (Ø 1,2 mm AWG 17)		50 m (165 feet)	50 m (165 feet)	190 m (625 feet)	60 m (195 feet)	150 m (495 feet)	
1 mm ² (Ø 1,2 mm AWG 17)		50 m (165 feet)	50 m (165 feet)	120 m (395 feet)	40 m (130 feet)	100 m (330 feet)	
1,5 mm ² (Ø 1,4 mm AWG 15)		75 m (245 feet)	100 m (330 feet)	190 m (625 feet)	60 m (195 feet)	150 m (495 feet)	
2,5 mm ² (Ø 1,8 mm AWG 13)		100 m (330 feet)	150 m (495 feet)	190 m (625 feet)	60 m (195 feet)	150 m (495 feet)	

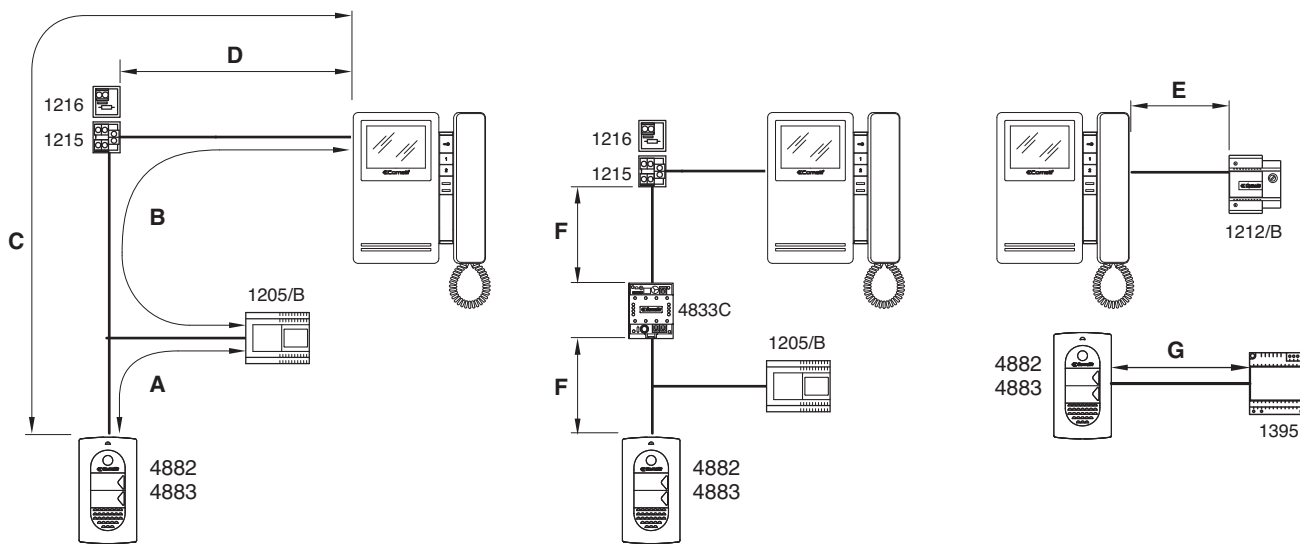

Funcionamento



Em caso de curto-circuito persistente na linha bus, o posto externo emite um som de sinalização intermitente.

O visitante, ao premir a tecla de chamada, acende a luz que o ilumina, activa a campainha interna de chamada (se a função privacidade não estiver activada), e a sua imagem será exibida no(s) monitor(es) principal(ais) durante cerca de 60 segundos.

A duração máxima da conversação entre posto externo e posto interno é de 90 segundos.

No posto externo ouve-se um som de chamada a entrar; se em sistemas com 2 ou mais entradas, no momento da chamada, o posto externo emitir o som de ocupado em vez do som de uma campainha, significa que está a decorrer outra comunicação com outro posto externo.

Para a programação dos endereços de utilizadores diferentes daqueles programados de fábrica (1 e 2), consultar a pág. 105.

Para as funções de intercomunicação do sistema Magis kit, consulte a pág. 107.

Descrição das configurações e funcionamento dos botões

Configurações do monitor Art. 6402E e telefone intercomunicador Style

Posições dos microinterruptores do monitor Art. 6402E

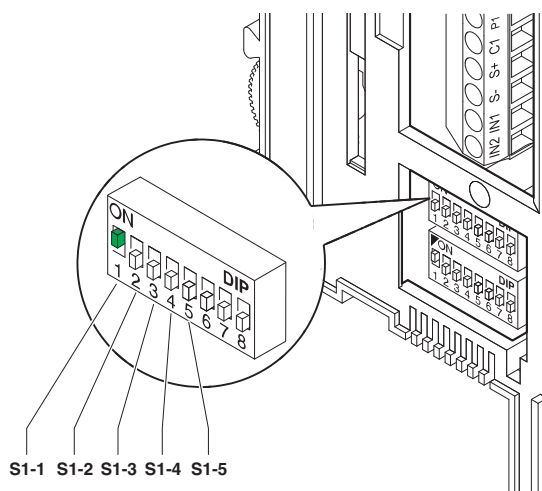

► Nos telefones intercomunicadores Art. 2608, Art. 2610 e Art. 2628 colocar os dip switches **S1-6, S1-7, S1-8** em **OFF**.

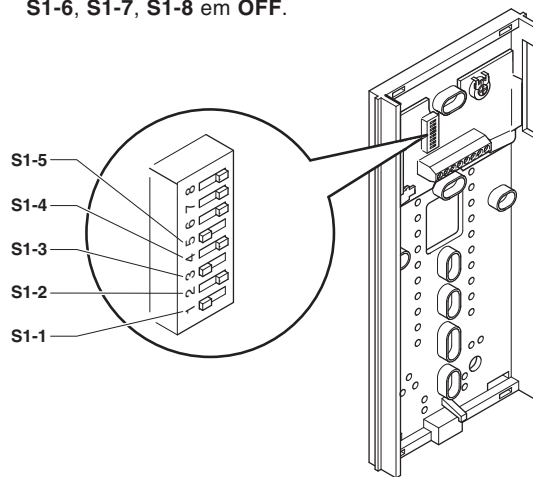

Os valores de **S1-1, S1-2, S1-3, S1-4** e **S1-5** definem o **endereço de chamada** do monitor e dos telefones intercomunicadores como indicado na seguinte tabela.

TAB. A Endereços da coluna

Código	S1
1	

Descrição das funções das teclas

☞ **Abre-porta:** A pressão do botão Abre-porta activa o fecho ligado ao posto externo.

Actuador: A pressão do botão programado na modalidade Actuador permite a activação do Art. 1256 que pode ser utilizado, por exemplo, para accionar a abertura de portões, de portas basculantes ou para activar o módulo de câmaras cíclicas Art 1259C.

Botão Livre: A indicação Botão livre indica a possibilidade de utilizar o botão como contacto C.NO na bateria de bornes mediante oportunas programações, tal como ilustrado na variante SB2/AAM2 na página 125.

Acendimento automático/pedido de vídeo

- ✓ O acendimento automático pode ser desabilitado.
- ✓ O acendimento automático é possível apenas com o aparelho em repouso.
- ✓ O acendimento automático é aconselhado apenas em instalações com 1 ou 2 entradas.

Premir o botão 2 configurado neste modo permite visualizar no ecrã do monitor a imagem transmitida do posto externo, mesmo que não tenha sido feita nenhuma chamada.

Em sistemas equipados com 2 postos externos é possível visualizar alternativamente a imagem de um posto externo ou do outro (função "báscula"), através de sucessivas pressões no botão 2.

Em monitores secundários (DIP 8 de S2 em ON), o botão 2 tem também a função de pedido de vídeo, permite activar um monitor após uma chamada do posto externo.

Activação:

- premir o botão dedicado ao acendimento automático do monitor por um tempo superior a 4 segundos.
- » campainha de confirmação.

Desactivação:

- premir o botão dedicado ao acendimento automático do monitor por um tempo superior a 4 segundos.
- » ouvem-se 4 sons de confirmação.

Acendimento:

- premir e soltar imediatamente o botão dedicado (botão 2 - se forem mantidas as configurações de fábrica).

Chamada à central

Premir o botão configurado neste modo permite enviar uma chamada para a central de portaria.

Chamada de intercomunicação monofamiliar

Esta função permite enviar uma chamada a outros aparelhos (vídeo-intercomunicadores e/ou telefones intercomunicadores) configurados no mesmo endereço de chamada.

► O destinatário da chamada, levantando o auscultador, entra em comunicação com o emissor da chamada. A comunicação termina quando se pouso o auscultador.

Uma chamada de intercomunicação não é prioritária relativamente a uma conversação/chamada com o posto externo.

Neste caso, durante uma tentativa de chamada de intercomunicação, a luz indicadora piscará por alguns segundos para sinalizar que o sistema está ocupado.

Chamada da unidade externa

De qualquer forma, uma chamada da unidade externa tem sempre prioridade sobre uma comunicação no intercomunicador (A activação da comunicação com a unidade externa interrompe a conversação que estava a decorrer através do intercomunicador).

Neste caso, os utilizadores que já estão em comunicação ouvirão um som semelhante ao toque de chamada no auscultador, se esta for dirigida aos mesmos, ou então um som triplo.

► Para atender a chamada do posto externo, basta levantar o auscultador de qualquer aparelho livre ou pousar e levantar o auscultador da unidade ocupada numa comunicação de intercomunicação.

Médico

Esta função permite a activação automática da abertura da porta em chamadas do posto externo ao endereço do posto interno em qual a função foi activada.

Activação/desactivação:

- manter premido por 2 segundos o botão configurado para a função.
- » A luz indicadora permanece acesa quando a função se encontra activa.

Monitores suplementares principais ou secundários

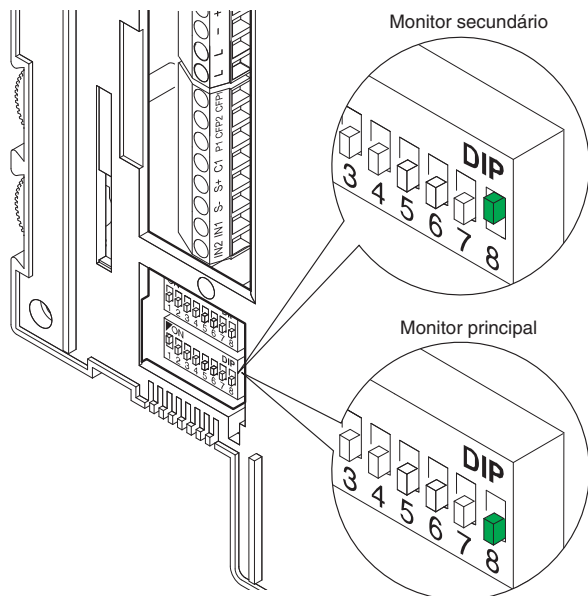

A programação do DIP 8 de S2 define se o suporte em questão será controlado como principal (P) ou secundário (S).

O posto externo pode gerir até 4 vídeo-intercomunicadores ou telefones intercomunicadores por cada botão de chamada.

Na configuração clássica de Magis Kit é possível ter no máximo 2 vídeo-intercomunicadores principais e 2 vídeo-intercomunicadores secundário para o botão de chamada, todos alimentados pelo mesmo **Art. 1205/B**. Existe a possibilidade de gerir até 3 vídeo-intercomunicadores principais dentro da mesma unidade familiar (isto é, configurados com o mesmo código utilizador). Nesta configuração especial, os vídeo-intercomunicadores principais adicionais devem ser alimentados com o **Art. 1212/B** (consultar a variante MSK/HCA, MSK/IC na pág. 118, 119). Quando se efectua uma chamada do posto externo, o monitor que se acende é o vídeo-intercomunicador principal.

Os eventuais monitores secundários da mesma unidade familiar permanecerão desligados.

Ao atender a chamada do posto externo de um vídeo-intercomunicador secundário, a imagem será automaticamente visualizada no monitor.

Neste ponto o monitor do vídeo-intercomunicador principal será desligado e a imagem será visualizada no monitor do vídeo-intercomunicador no qual foi premido o botão 2 - acendimento automático/pedido de vídeo.

Para visualizar a imagem sem activar o áudio no posto externo, premir o botão 2 - acendimento automático/pedido de vídeo.

Configurações dos botões predefinidos

DIP S2				com Art. 6433, 6434							
DIP 1	DIP 2	DIP 3	DIP 4	P1	P2			P3	P4	P5	P6
0	0	0	0	CCS	AI			ACT	D	PAN	K
1	0	0	0	ACT	AI			INT	INTb	D	CCS
0	1	0	0	INT	AI			INTb	ACT	CCS	CCP
1	1	0	0	ACT	CCS			CCP	PAN	K	D
0	0	1	0	ACT	ACT	ACT		ACT	ACT	ACT	ACT
1	0	1	0	INT	ACT			CCS	CCP	INTb	PAN
0	1	1	0	AI	D			K	CCS	CCP	INTb
1	1	1	0	INTb	INT			AI	INT	PAN	D
0	0	0	1	CCS	PAN			D	AI	INT	INTb
1	0	0	1	K	CCS			PAN	CCP	AI	INT
0	1	0	1	CCP	K			PAN	ACT	INT	AI
1	1	0	1	PAN	CCP			CCS	K	ACT	D
0	0	1	1	D	INTb			INT	ACT	AI	CCS
1	0	1	1	INT	INT			INT	INT	INT	INT
0	1	1	1	NULL	NULL	NULL	NULL	NULL	NULL	NULL	NULL
1	1	1	1						PROG		

Legenda

	Abertura da porta	CCS	Chamada à central	INTb	Intercomunicação bifamiliar - apenas para KIT
	Áudio	K	Chamada ao telefone intercomunicador do vigilante	NULL	Nenhuma função
ACT	Actuador	D	Médico	PROG	Funções programadas, consultar a pág. 106-107-108-109. Nesta programação dos dips, os botões gerem as funções programadas; os botões NÃO programados gerem as funções indicadas na linha 0000
AI	Acendimento automático	PAN	Pânico		
CCP	Chamada à central principal	INT	Intercomunicação programável geral ou selectiva - de série chamada monofamiliar para KIT e Simplebus Top		



Avisos gerais sobre a programação dos botões

Caso as configurações predefinidas (consultar a tabela da pág. 106) não reflectam as necessidades, é possível programar de modo diferente os botões segundo os procedimentos a seguir descritos.

No fim, colocar os DIPs 1-2-3-4 de S2 na combinação 1111 (programação PROG nas tabelas de configuração, pág. 106,107,108,109). Nesta

configuração dos DIPs, os botões gerem as funções programadas; os botões NÃO programados gerem as funções indicadas na linha 0000 (consultar a tabela da pág. 106). Repor em S1 a configuração do código de utilizador, consultar a tabela A da pág. 105.

Programações dos botões para o actuador geral ou com endereço

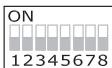
DIP S2				com Art. 6433, 6434				DIP S1				
DIP 1	DIP 2	DIP 3	DIP 4	P1	P2		P3	P4	P5	P6	ENDEREÇO 	
0	0	0	0				ACT					
1	0	0	0	ACT								
0	1	0	0					ACT				
1	1	0	0	ACT								
0	0	1	0	ACT	ACT	ACT	ACT	ACT	ACT	ACT		
1	0	1	0		ACT							
0	1	1	0									
1	1	1	0									
0	0	0	1									
1	0	0	1									
0	1	0	1					ACT				
1	1	0	1						ACT			
0	0	1	1									
1	0	1	1									
0	1	1	1									
1	1	1	1									

Exemplo:

num monitor com código de utilizador 5 programação P1 = actuador geral, P2 = actuador com endereço com o código 125.

1. Colocar os DIPs 5-6 de S2 na combinação 01.

» a luz indicadora (verde) pisca.

2. Consultar a tabela da pág. 107 e escolher uma combinação onde surja a função de actuador (ACT) para os botões que se pretende programar.

EX.: para P1 = actuador geral configurar os DIPs 1-2-3-4 de S2 na combinação 1000 ou 1100 ou 0010 (P1 = ACT), configurar o dip de S1 na combinação 11111111, passar ao ponto 3.

EX.: para P2 = actuador com endereço com código 125, configurar os DIPs 1-2-3-4 de S2 na combinação 0010 ou 1010 (P2 = ACT), configurar S1 com o endereço 125 segundo a **tabela C** da pág. 109, passar ao ponto 3.

3. Premir e libertar o botão ao qual se pretende associar a função.

» a luz indicadora (verde) acende-se.

» som de confirmação no auscultador.

4. Para sair da programação, colocar os DIPs 5-6 de S2 na combinação 00.

» a luz indicadora (verde) desliga-se.











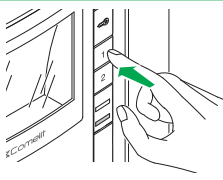

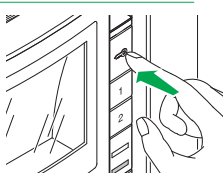
5. No final da programação, colocar os DIPs 1-2-3-4 de S2 na combinação 1111. Repor em S1 a configuração do código de utilizador, consultar a **tabela A** da pág. 105.

Programação para a chamada de intercomunicação

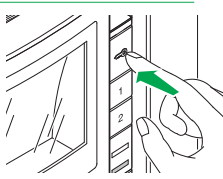

Chamada de intercomunicação geral e selectiva **NÃO** são compatíveis na mesma coluna.

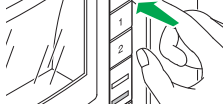







Programação/cancelamento do endereço de intercomunicação (apenas para intercomunicação selectiva)

S1	! 1)						! 2)						3)	
	DIP 1	DIP 2	DIP 3	DIP 4	DIP 5	DIP 6	S2							
Programação; configurar o código, TAB. B pág. 107	0	0	0	1	1	1								
Cancelar  	1	1	1	1	1	1								



Tomar nota da configuração de S2, S1 e repor no final da programação.

TAB. B Endereços de intercomunicação selectiva

Code	Dip switch ON	S1	Code	Dip switch ON	S1	Code	Dip switch ON	S1
1	1		4	4		7	7	
2	2		5	5		8	8	
3	3		6	6				

É necessário configurar o endereço de intercomunicação em todos os postos internos da coluna.

É possível associar o mesmo endereço de intercomunicação a um máx. de 3 postos internos.

Para a chamada de grupo, seleccionar em simultâneo os códigos de intercomunicação desejados (máx. 3).

Programação dos botões para a chamada de intercomunicação

DIP S2				com Art. 6433, 6434				DIP S1					
DIP 1	DIP 2	DIP 3	DIP 4	P1	P2			P3	P4	P5	P6	ENDEREÇO 	
0	0	0	0										
1	0	0	0					INT	INTb				
0	1	0	0	INT				INTb					
1	1	0	0										
0	0	1	0										
1	0	1	0	INT						INTb			
0	1	1	0								INTb		
1	1	1	0	INTb	INT				INT				
0	0	0	1							INT	INTb		
1	0	0	1								INT		
0	1	0	1							INT			
1	1	0	1										
0	0	1	1		INTb			INT					
1	0	1	1	INT	INT			INT	INT	INT	INT		
0	1	1	1										
1	1	1	1										
PROG													

Exemplo 1 - Intercomunicador selectivo

num monitor com código de utilizador 1 e endereço de intercomunicação 1 programação P3 = intercomunicação selectiva ao endereço 2, P4 = intercomunicação selectiva ao endereço 3.

Exemplo 2 - Intercomunicador KIT (intercomunicação entre 2 endereços adjacentes no intervalo de 1 a 30, a começar por ímpar):

num monitor com código de utilizador 1 programação P3 = chamada geral interna, P4 = intercomunicação bifamiliar ao endereço 2.

1. Colocar os DIPs 5-6 de S2 na combinação 01.

» a luz indicadora (verde) pisca.

2. Consultar a tabela da pág. 108 e escolher uma combinação onde surja a função de intercomunicação (INT ou INTb) para os botões que se pretende programar.

EX. 1: para P3 = intercomunicação selectiva, configurar os DIPs 1-2-3-4 de S2 na combinação 1000 ou 0011 ou 1011 (P3 = INT), configurar S1 com o endereço 2 segundo a **tabela B** da pág. 107, passar ao ponto 3.

EX. 1: para P4 = intercomunicação selectiva, configurar os DIPs 1-2-3-4 de S2 na combinação 1110 ou 1011 (P4 = INT), configurar S1 com o endereço 3 segundo a **tabela B** da pág. 107, passar ao ponto 3.

EX. 2: para P3 = chamada geral interna e P4 = intercomunicação bifamiliar, configurar os DIPs 1-2-3-4 de S2 na combinação 1000 (P3 = INT, P4 = INTb), configurar S1 com o código de utilizador 1 segundo a **tabela A** da pág. 105, passar ao ponto 3.

3. Premir e libertar o botão ao qual se pretende associar a função.

» a luz indicadora (verde) acende-se.

» som de confirmação no auscultador.

4. Para sair da programação, colocar os DIPs 5-6 de S2 na combinação 00.

» a luz indicadora (verde) desliga-se.

5. No final da programação, colocar os DIPs 1-2-3-4 de S2 na combinação 1111. Repor em S1 a configuração do código de utilizador, consultar a **tabela A** da pág. 105.

Programação dos botões para outras funções

DIP S2				com Art. 6433, 6434				DIP S1					
DIP 1	DIP 2	DIP 3	DIP 4	P1	P2			P3	P4	P5	P6	PROG	
0	0	0	0	CCS	AI				D	PAN	K		
1	0	0	0		AI					D	CCS		
0	1	0	0		AI					CCS	CCP		
1	1	0	0		CCS			CCP	PAN	K	D		
0	0	1	0										
1	0	1	0					CCS	CCP		PAN		
1	1	1	0	AI	D			K	CCS	CCP	D		
0	0	0	1	CCS	PAN			AI					
1	0	0	1	K	CCS			PAN	CCP	AI			
0	1	0	1	CCP	K			PAN	CCP		AI		
1	1	0	1	PAN	CCP			CCS	K		D		
0	0	1	1	D						AI	CCS		
1	0	1	1										
0	1	1	1	NULL	NULL	NULL	NULL	NULL	NULL	NULL	NULL		NULL
PROG													

Legenda

	Abertura da porta	CCS	Chamada à central	NULL	Nenhuma função
	Áudio	K	Chamada ao telefone intercomunicador do vigilante	PROG	Funções programadas
AI	Acendimento automático	D	Médico		
CCP	Chamada à central principal	PAN	Pânico		

Exemplo:

num monitor com código de utilizador 5 programação P5 = acendimento automático, P6 = chamada à central.

1. Colocar os DIPs 5-6 de S2 na combinação 01.

» a luz indicadora (verde) pisca.

2. Consultar a tabela da pág. 108 e escolher uma combinação onde surjam as funções desejadas/necessárias para os botões que se pretende programar.

EX.: para P5 = acendimento automático P6 = chamada à central configurar os DIPs 1-2-3-4 de S2 na combinação 0011 (P5 = AI, P6 = CCS).

3. Premir e libertar o botão ao qual se pretende associar a função.

» a luz indicadora (verde) acende-se.

» som de confirmação no auscultador.

4. Para sair da programação, colocar os DIPs 5-6 de S2 na combinação 00.

» a luz indicadora (verde) desliga-se.

5. No final da programação, colocar os DIPs 1-2-3-4 de S2 na combinação 1111.

TAB. C Endereços da coluna

Code	Dip switch ON	Code	Dip switch ON	Code	Dip switch ON	Code	Dip switch ON	Code	Dip switch ON	Code	Dip switch ON	Code	Dip switch ON	Code	Dip switch ON
1	1	31	1,2,3,4,5	61	1,3,4,5,6	91	1,2,4,5,7	121	1,4,5,6,7	151	1,2,3,5,8	181	1,3,5,6,8	211	1,2,5,7,8
2	2	32	6	62	2,3,4,5,6	92	3,4,5,7	122	2,4,5,6,7	152	4,5,8	182	2,3,5,6,8	212	3,5,7,8
3	1,2	33	1,6	63	1,2,3,4,5,6	93	1,3,4,5,7	123	1,2,4,5,6,7	153	1,4,5,8	183	1,2,3,5,6,8	213	1,3,5,7,8
4	3	34	2,6	64	7	94	2,3,4,5,7	124	3,4,5,6,7	154	2,4,5,8	184	4,5,6,8	214	2,3,5,7,8
5	1,3	35	1,2,6	65	1,7	95	1,2,3,4,5,7	125	1,3,4,5,6,7	155	1,2,4,5,8	185	1,4,5,6,8	215	1,2,3,5,7,8
6	2,3	36	3,6	66	2,7	96	6,7	126	2,3,4,5,6,7	156	3,4,5,8	186	2,4,5,6,8	216	4,5,7,8
7	1,2,3	37	1,3,6	67	1,2,7	97	1,6,7	127	1,2,3,4,5,6,7	157	1,3,4,5,8	187	1,2,4,5,6,8	217	1,4,5,7,8
8	4	38	2,3,6	68	3,7	98	2,6,7	128	8	158	2,3,4,5,8	188	3,4,5,6,8	218	2,4,5,7,8
9	1,4	39	1,2,3,6	69	1,3,7	99	1,2,6,7	129	1,8	159	1,2,3,4,5,8	189	1,3,4,5,6,8	219	1,2,4,5,7,8
10	2,4	40	4,6	70	2,3,7	100	3,6,7	130	2,8	160	6,8	190	2,3,4,5,6,8	220	3,4,5,7,8
11	1,2,4	41	1,4,6	71	1,2,3,7	101	1,3,6,7	131	1,2,8	161	1,6,8	191	1,2,3,4,5,6,8	221	1,3,4,5,7,8
12	3,4	42	2,4,6	72	4,7	102	2,3,6,7	132	3,8	162	2,6,8	192	7,8	222	2,3,4,5,7,8
13	1,3,4	43	1,2,4,6	73	1,4,7	103	1,2,3,6,7	133	1,3,8	163	1,2,6,8	193	1,7,8	223	1,2,3,4,5,7,8
14	2,3,4	44	3,4,6	74	2,4,7	104	4,6,7	134	2,3,8	164	3,6,8	194	2,7,8	224	6,7,8
15	1,2,3,4	45	1,3,4,6	75	1,2,4,7	105	1,4,6,7	135	1,2,3,8	165	1,3,6,8	195	1,2,7,8	225	1,6,7,8
16	5	46	2,3,4,6	76	3,4,7	106	2,4,6,7	136	4,8	166	2,3,6,8	196	3,7,8	226	2,6,7,8
17	1,5	47	1,2,3,4,6	77	1,3,4,7	107	1,2,4,6,7	137	1,4,8	167	1,2,3,6,8	197	1,3,7,8	227	1,2,6,7,8
18	2,5	48	5,6	78	2,3,4,7	108	3,4,6,7	138	2,4,8	168	4,6,8	198	2,3,7,8	228	3,6,7,8
19	1,2,5	49	1,5,6	79	1,2,3,4,7	109	1,3,4,6,7	139	1,2,4,8	169	1,4,6,8	199	1,2,3,7,8	229	1,3,6,7,8
20	3,5	50	2,5,6	80	5,7	110	2,3,4,6,7	140	3,4,8	170	2,4,6,8	200	4,7,8	230	2,3,6,7,8
21	1,3,5	51	1,2,5,6	81	1,5,7	111	1,2,3,4,6,7	141	1,3,4,8	171	1,2,4,6,8	201	1,4,7,8	231	1,2,3,6,7,8
22	2,3,5	52	3,5,6	82	2,5,7	112	5,6,7	142	2,3,4,8	172	3,4,6,8	202	2,4,7,8	232	4,6,7,8
23	1,2,3,5	53	1,3,5,6	83	1,2,5,7	113	1,5,6,7	143	1,2,3,4,8	173	1,3,4,6,8	203	1,2,4,7,8	233	1,4,6,7,8
24	4,5	54	2,3,5,6	84	3,5,7	114	2,5,6,7	144	5,8	174	2,3,4,6,8	204	3,4,7,8	234	2,4,6,7,8
25	1,4,5	55	1,2,3,5,6	85	1,3,5,7	115	1,2,5,6,7	145	1,5,8	175	1,2,3,4,6,8	205	1,3,4,7,8	235	1,2,4,6,7,8
26	2,4,5	56	4,5,6	86	2,3,5,7	116	3,5,6,7	146	2,5,8	176	5,6,8	206	2,3,4,7,8	236	3,4,6,7,8
27	1,2,4,5	57	1,4,5,6	87	1,2,3,5,7	117	1,3,5,6,7	147	1,2,5,8	177	1,5,6,8	207	1,2,3,4,7,8	237	1,3,4,6,7,8
28	3,4,5	58	2,4,5,6	88	4,5,7	118	2,3,5,6,7	148	3,5,8	178	2,5,6,8	208	5,7,8	238	2,3,4,6,7,8
29	1,3,4,5	59	1,2,4,5,6	89	1,4,5,7	119	1,2,3,5,6,7	149	1,3,5,8	179	1,2,5,6,8	209	1,5,7,8	239	1,2,3,4,6,7,8
30	2,3,4,5	60	3,4,5,6	90	2,4,5,7	120	4,5,6,7	150	2,3,5,8	180	3,5,6,8	210	2,5,7,8	*240	5,6,7,8

*NOTA: o código 240 está reservado para a central de portaria

Reinicialização da programação

! 1)		! 2)						3)		4)
S1	DIP 1	DIP 2	DIP 3	DIP 4	DIP 5	DIP 6	S2			S1/S2/LED1
<p>DIP ON</p>	1	1	1	1	1	1		<p>5 sec</p>	<p>2 sec</p>	<p>Tomar nota da configuração de S2, S1 e repor no final da programação</p>
<p>Configurações de fábrica:</p> <ul style="list-style-type: none"> • Funções dos botões em função da combinação dos DIPs 1-2-3-4 de S2; • Endereço de intercomunicação ausente; • Função intervalo e endereços mín. e máx. permitidos; • Reinício campainhas • Entrada IN 1 ⇒ Luz indicadora (predefinida). 										

Programação range/campainhas		Realizar as operações de 1 a 4							
		! 1)	! 2)						3)
	S1	DIP 1	DIP 2	DIP 3	DIP 4	DIP 5	DIP 6	S2	S1/S2/LED1
Endereço mínimo intervalo	configurara código, TAB. C na pág. 109	0	0	0	0	1	0		<p>Tomar nota da configuração de S2, S1 e repor no final da programação</p>
Endereço máximo intervalo		0	0	0	0	0	0		
Activação intervalo									
Desactivação intervalo									
Seleção de campainha polifónica		0	1	0	1	1	0		
Seleção de campainha sons (predefinida)									

Realizar as operações de 1 a 4																				
		! 2)					3)		4)											
! 1)		S1	DIP 1	DIP 2	DIP 3	DIP 4	DIP 5	DIP 6	S2											
Programação da entrada IN1 para indicação luz indicador/alarme/abertura da porta/actuador																				
Entrada IN 1 ⇒ Luz indicadora (predefinida), consultar as página 124			0	0	0	1	1	0												
Entrada IN 1 ⇒ ALARME, consultar as página 124			0	0	0	1	1	0												
Entrada IN 1 ⇒ ABERTURA DA PORTA, consultar as página 124																				
Entrada IN 1 ⇒ ACTUADOR COM ENDEREÇO, consultar as página 124			0	0	1	0	1	0												
Entrada IN 1 ⇒ ACTUADOR GENÉRICO, consultar as página 124																				

! Tomar nota da configuração de S2, S1 e repor no final da programação

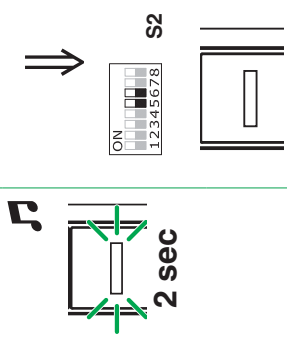

Programação directa da chamada de intercomunicação

Permite a programação das chamadas de intercomunicação directamente dos postos internos.

✓ Requer 2 operadores.

Fase 1: entrada em programação

Operador 1 e operador 2 realizam as seguintes operações nos 2 postos internos:

1. Configurar os DIPs 1-2-3-4 de S2 na combinação 1111.
2. Levantar o auscultador.
3. Premir a tecla 1 e 2 por 3 seg.
4. *O posto interno emite 1 som.*
» *A luz indicadora verde pisca.*
» *O posto interno entra em comunicação.*
» *Neste momento os 2 operadores estão em comunicação entre si.*

Fase 2: programação da chamada de intercomunicação

Operador 1:

- ▶ Premir o botão que pretende programar para chamar o operador 2 (ex.: 2).
- » *O posto interno do operador 1 emite um som de confirmação.*

Operador 2:

- ▶ Premir o botão que pretende programar para chamar o operador 1 (ex.: 1).
- » *O posto interno do operador 2 emite um som de confirmação.*

Operador 1/Operador 2:

- ▶ Desligar o aparelho.
- » *O posto interno emite 1 som.*
» *A programação dos 2 postos internos está assim concluída.*

Para programar outro posto interno, passar à Fase 3.



Fase 3: programar outros postos internos

Operador 1/Operador 2:

1. Ao chegar à nova posição realizar a fase 1 para entrar em comunicação.
2. Repetir a fase 2.

NOTA Caso se receba uma chamada durante a programação, é necessário responder à chamada e posteriormente retomar a fase de programação.

Variante das campanhas do monitor

1. Manter premido o botão  até que seja emitido um som de confirmação (a operação é possível apenas nos aparelhos em situação de repouso; caso contrário a luz indicadora piscará para avisar o utilizador).
2. Premir e libertar o botão  :
 - 1 vez (é emitido um som de confirmação) para modificar a campanha de chamada do posto exterior.
 - 2 vezes (são emitidos 2 sons de confirmação) para modificar a campanha de chamada da central.
 - 3 vezes (são emitidos 3 sons de confirmação) para modificar a campanha da chamada de intercomunicação do posto interno.
 - 4 vezes (são emitidos 4 sons de confirmação) para modificar a campanha de chamada do andar.
 Ao premir o botão  novamente, repete a sequência descrita acima.
3. Premir e libertar o botão 1 para percorrer as várias campanhas disponíveis na sequência.
4. Premir o botão 2 para confirmar a selecção da última campanha ouvida e para sair (em qualquer altura) do modo de selecção do som da campanha do monitor. Ao sair do modo de selecção da campanha do monitor, será emitido um som de confirmação.

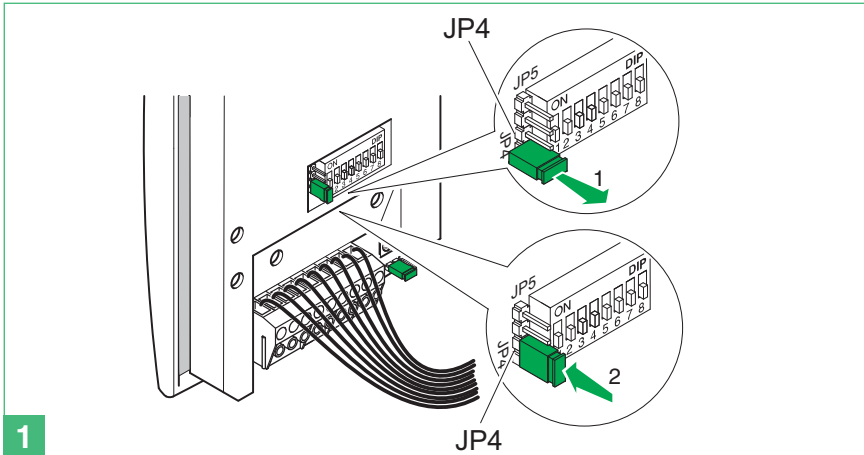

1

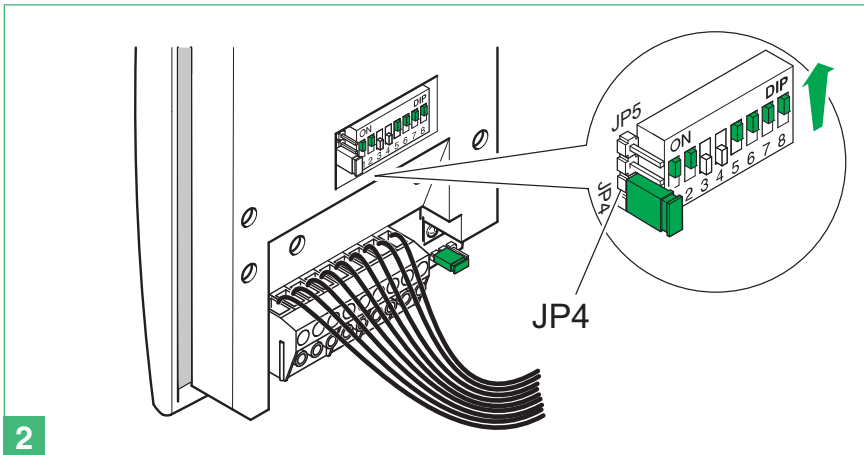

2

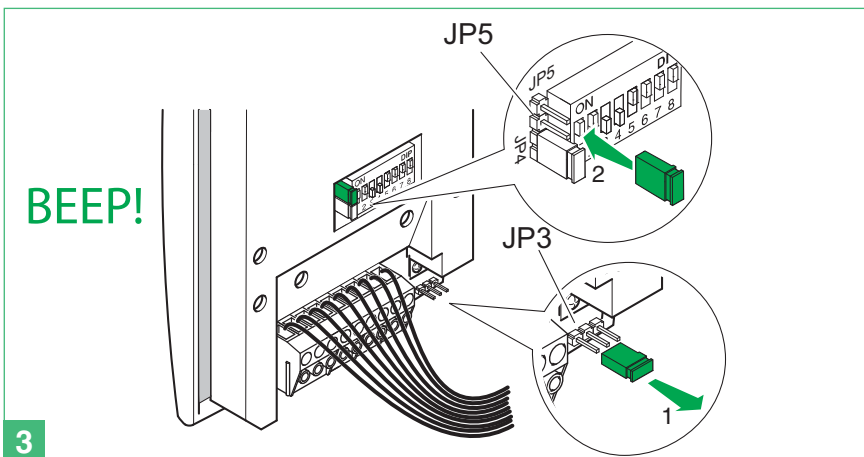

3

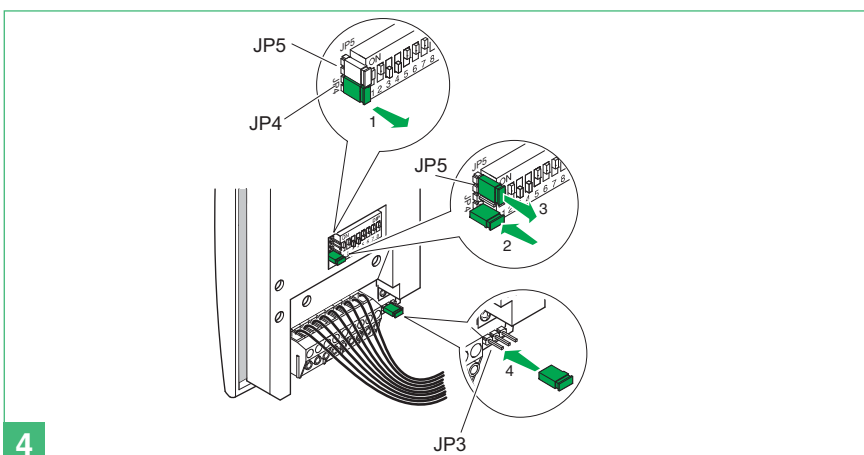

4

Código	Dip switch ON	
Fechadura		
245	1,3,5,6,7,8	Tempo fechadura: 2 seg. + som desactivado (predefinição)
246	2,3,5,6,7,8	Som de confirmação fechadura: activado
247	1,2,3,5,6,7,8	Tempo fechadura: 8 seg.
252	3,4,5,6,7,8	Abertura da porta sempre activada (predefinição)
253	1,3,4,5,6,7,8	Abertura da porta activada apenas para o utilizador que recebe a chamada

Funções do equipamento		
243	1,2,5,6,7,8	Tempo de espera reiniciação: 10 seg. (predefinição)
244	3,5,6,7,8	Tempo de espera reiniciação: 1 seg.
248	4,5,6,7,8	Envio de chamada: única (predefinição)
249	1,4,5,6,7,8	Envio chamada: tripla

Reposição predefinição		
254	2,3,4,5,6,7,8	

No Art. 4882 é possível efectuar uma série de acções de programação especial, de acordo com os diversos requisitos da instalação.

1. Aceder ao modo de programação colocando o comutador de derivação JP4 na vertical (Fig. 1).
2. Configurar nos dip switches o código relativo à função que se pretende programar (Fig. 2), segundo a tabela na pág. 113.
3. Confirmar a função configurada colocando o comutador de derivação JP3 na posição JP5 (Fig. 3) e aguardar que seja emitido um som de confirmação.
4. Para realizar outra programação especial, remover o comutador de derivação JP5 e repetir o procedimento descrito no ponto 2 e 3.
5. No final do procedimento voltar a colocar os comutadores de derivação nas suas posições iniciais (Fig. 4): O comutador de derivação JP4 na posição horizontal e o segundo comutador de derivação JP5 na posição JP3.

- IT** Schema base per kit monofamiliari Art. 8471MC. Messa in funzione/verifica tensioni di impianto a riposo.
- EN** Basic diagram for single-family kit Art. 8471MC. Switching on/voltage check with system in standby.
- FR** Schéma base pour kit un usager Art. 8471MC. Mise en service/vérification tensions d'installation au repos.
- NL** Basisschema pour kits voor eengezinswoningen Art. 8471MC. Inwerkingstelling/spanningscontrole van een systeem in de ruststand.
- DE** Grundanschlussplan für Einfamiliensets Art. 8471MC. Inbetriebnahme/Spannungsprüfung an der Anlage in Standby.
- ES** Esquema básico para kits unifamiliares Art. 8471MC. Puesta en funcionamiento / comprobación de las tensiones con la instalación en reposo.
- PT** Esquema básico para kits monofamiliares Art. 8471MC. Colocação em funcionamento/controlo das tensões da instalação em pausa.

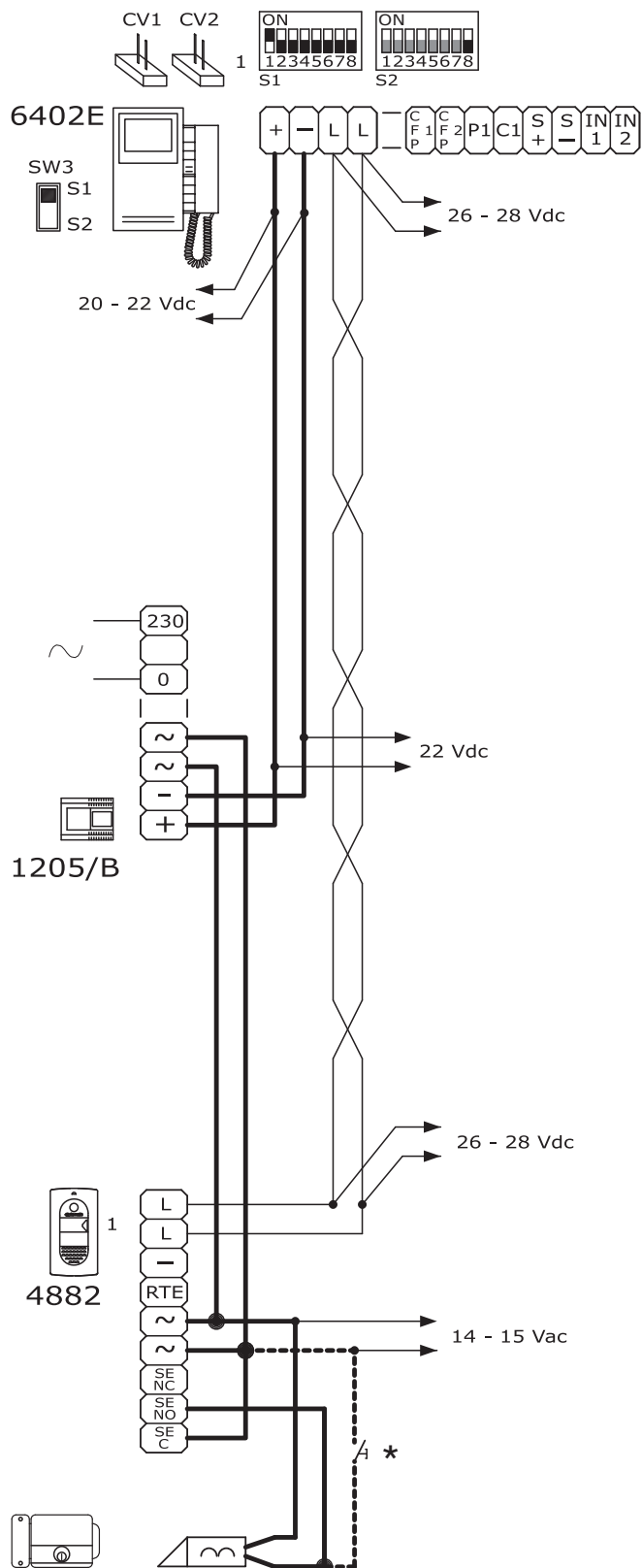

Per maggiori informazioni sulle distanze vedi pag. 8
 For further information about distances refer to page 24
 Pour plus de détails sur les distances faire référence au page 40
 Zie voor meer informatie over de afstanden pagina 56
 Siehe Seite 72 für weitere Informationen zu den Entfernungen
 Para mayor información sobre las distancias, véase la página 88
 Para mais informações sobre as distâncias, consultar as página 104

	A MAX	B MAX	C MAX
Comelit Art. 4576-4578 0,5 mm ² (Ø 0,8 mm AWG 20)		25 m (85 feet)	200 m (655 feet)
UTP5 cat. 5 0,2 mm ² (Ø 0,5 mm AWG 24)			190 m (625 feet)
0,28 mm ² (Ø 0,6 mm AWG 23)	5 m (15 feet)		190 m (625 feet)
0,5 mm ² (Ø 0,8 mm AWG 20)	25 m (85 feet)	25 m (85 feet)	190 m (625 feet)
1 mm ² (Ø 1,2 mm AWG 17)	50 m (165 feet)	50 m (165 feet)	190 m (625 feet)
1 mm ² (Ø 1,2 mm AWG 17)	50 m (165 feet)	50 m (165 feet)	120 m (395 feet)
1,5 mm ² (Ø 1,4 mm AWG 15)	75 m (245 feet)	100 m (330 feet)	190 m (625 feet)
2,5 mm ² (Ø 1,8 mm AWG 13)	100 m (330 feet)	150 m (495 feet)	190 m (625 feet)

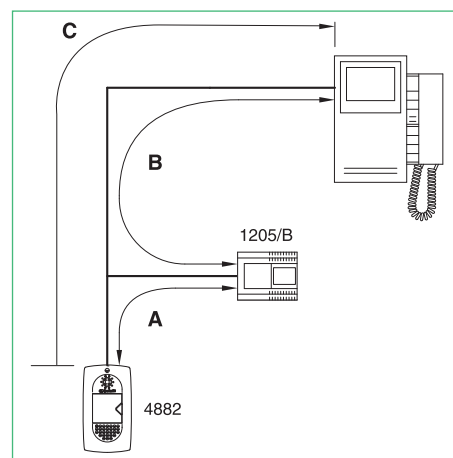

- *Pulsante comando apriporta locale
- *Local door-opener button
- *Bouton commande ouvre-porte local
- *Bedieningsknop lokale deuropener
- *Lokale Türöffnertaste
- *Pulsador abrepuertas local
- *Botão de comando abertura da porta local

- (IT) Schema per kit monofamiliari Art. 8471MC ampliati con un secondo Art. 4882
- (EN) Diagram for single-family kits Art. 8471MC extended with a second Art. 4882
- (FR) Schéma pour kit un usager Art. 8471MC amplifié par un second Art. 4882
- (NL) Schema voor kit eengezinswoning Art. 8471MC uitgebreid met een tweede Art. 4882
- (DE) Plan für Einfamilien-Set Art. 8471MC, erweitert mit einem zweiten Art. 4882
- (ES) Esquema para kits unifamiliares Art. 8471MC ampliados con un segundo Art. 4882
- (PT) Esquema para kits monofamiliares Art. 8471MC ampliados com um segundo Art. 4882

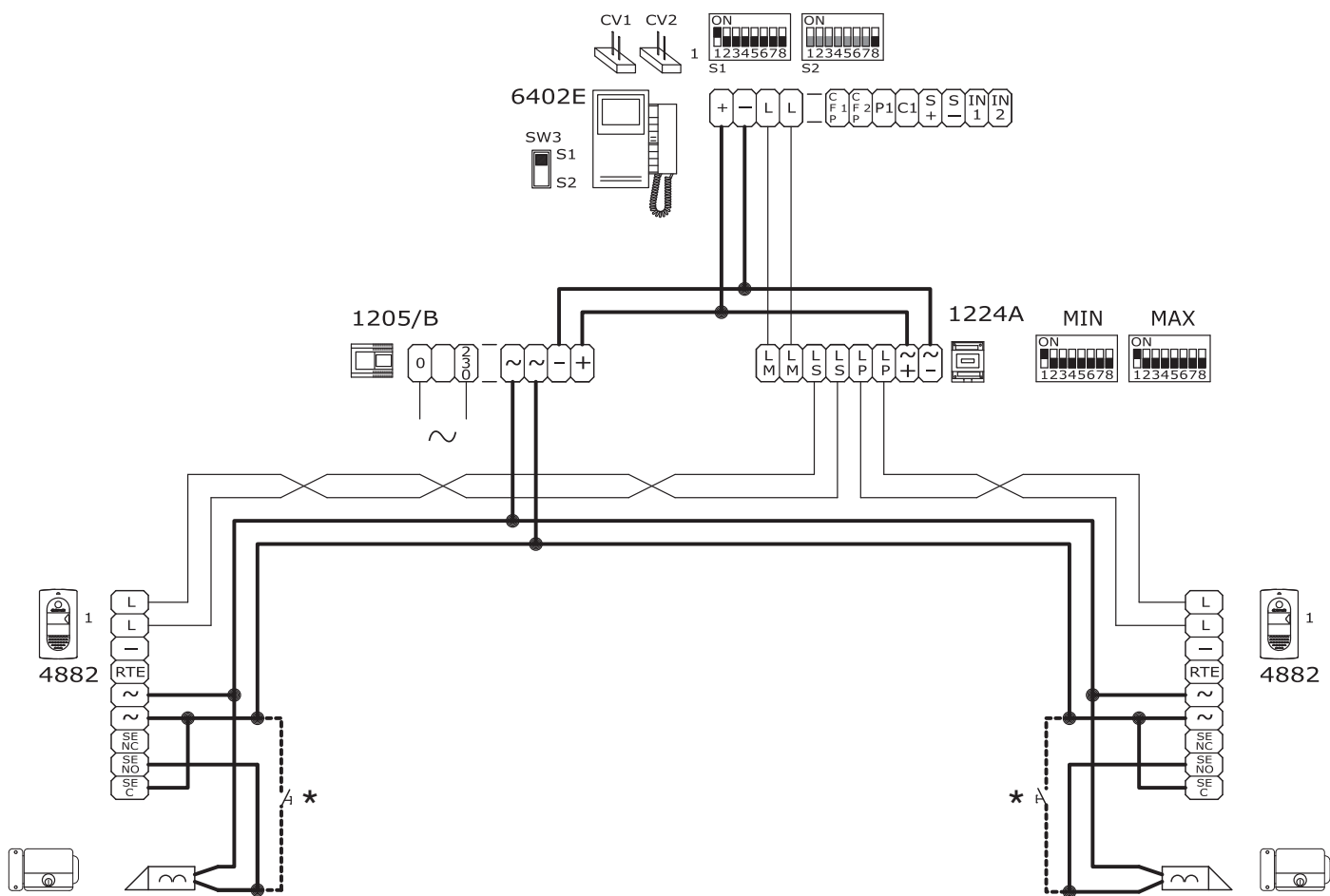

- *Pulsante comando apriporta locale
- *Local door-opener button
- *Bouton commande ouvre-porte local
- *Bedieningsknop lokale deuropener
- *Lokale Türöffnertaste
- *Pulsador abrepuertas local
- *Botão de comando abertura da porta local

- IT Schema per kit monofamiliare con alimentatore aggiuntivo Art. 1395
- EN Diagram for single-family kit with additional power supply unit Art. 1395
- FR Schéma pour kit un usager avec alimentateur complémentaire Art. 1395
- NL Schema voor kit voor eengezinswoningen met extra voedingstransformator Art. 1395
- DE Schaltplan für Einfamilienset mit zusätzlichem Netzteil Art. 1395
- ES Esquema para kits unifamiliares con alimentador adicional Art. 1395
- PT Esquema para kit monofamiliar com alimentador suplementar Art.1395

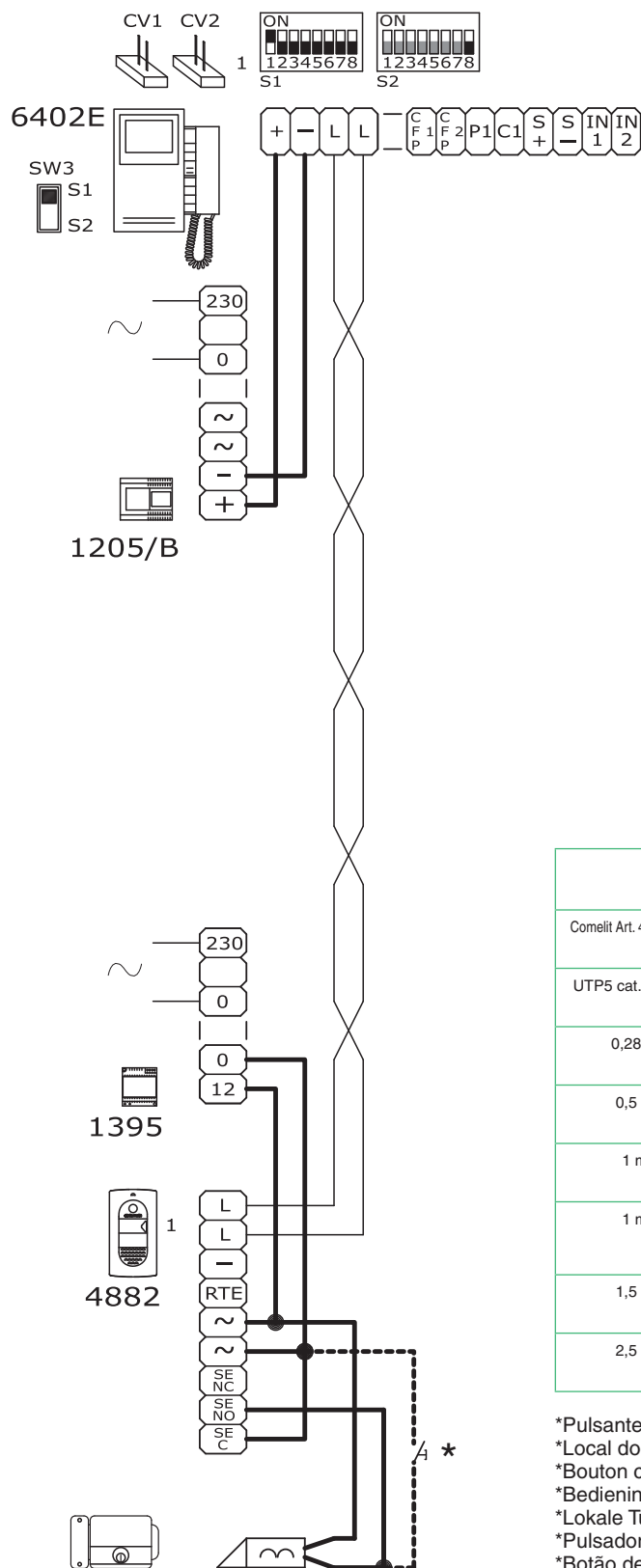

Per maggiori informazioni sulle distanze vedi pag. 8
 For further information about distances refer to page 24
 Pour plus de détails sur les distances faire référence au page 40
 Zie voor meer informatie over de afstanden pagina 56
 Siehe Seite 72 für weitere Informationen zu den Entfernungen
 Para mayor información sobre las distancias, véase la página 88
 Para mais informações sobre as distâncias, consultar as página 104

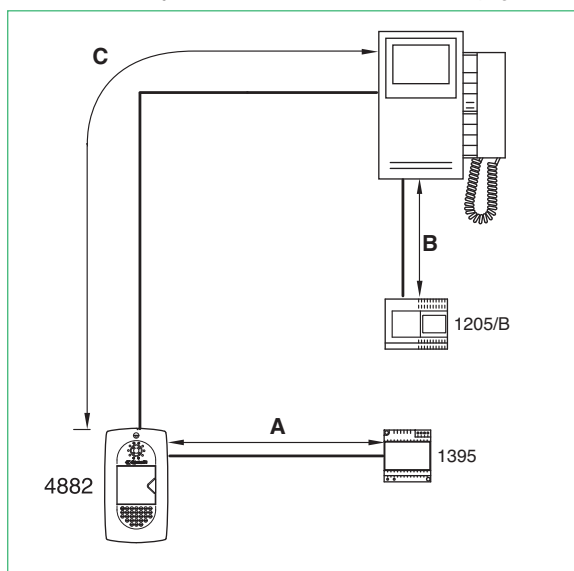

	A MAX	B MAX	C MAX	C MAX (Art. 4833C)
Comelit Art. 4576-4578 0,5 mm ² (Ø 0,8 mm AWG 20)		25 m (85 feet)	200 m (655 feet)	300 m (990 feet)
UTP5 cat. 5 0,2 mm ² (Ø 0,5 mm AWG 24)			190 m (625 feet)	300 m (990 feet)
0,28 mm ² (Ø 0,6 mm AWG 23)	5 m (15 feet)		190 m (625 feet)	300 m (990 feet)
0,5 mm ² (Ø 0,8 mm AWG 20)	25 m (85 feet)	25 m (85 feet)	190 m (625 feet)	300 m (990 feet)
1 mm ² (Ø 1,2 mm AWG 17)	50 m (165 feet)	50 m (165 feet)	190 m (625 feet)	300 m (990 feet)
1 mm ² (Ø 1,2 mm AWG 17)	50 m (165 feet)	50 m (165 feet)	120 m (395 feet)	200 m (660 feet)
1,5 mm ² (Ø 1,4 mm AWG 15)	75 m (245 feet)	100 m (330 feet)	190 m (625 feet)	300 m (990 feet)
2,5 mm ² (Ø 1,8 mm AWG 13)	100 m (330 feet)	150 m (495 feet)	190 m (625 feet)	300 m (990 feet)

- *Pulsante comando apriporta locale
- *Local door-opener button
- *Bouton commande ouvre-porte local
- *Bedieningsknop lokale deuropener
- *Lokale Türöffnertaste
- *Pulsador abrepuertas local
- *Botão de comando abertura da porta local

- IT Utilizzo modulo telecamera scorporata Art. 1259C
- EN Use of remote camera module Art. 1259C
- FR Emploi module caméra déportée Art. 1259C
- NL Gebruik module voor externe camera Art. 1259C

- DE Einsatz des separaten Kameramoduls Art. 1259C
- ES Uso del módulo telecámara separada Art. 1259C
- PT Utilização do módulo da câmara separada Art. 1259C

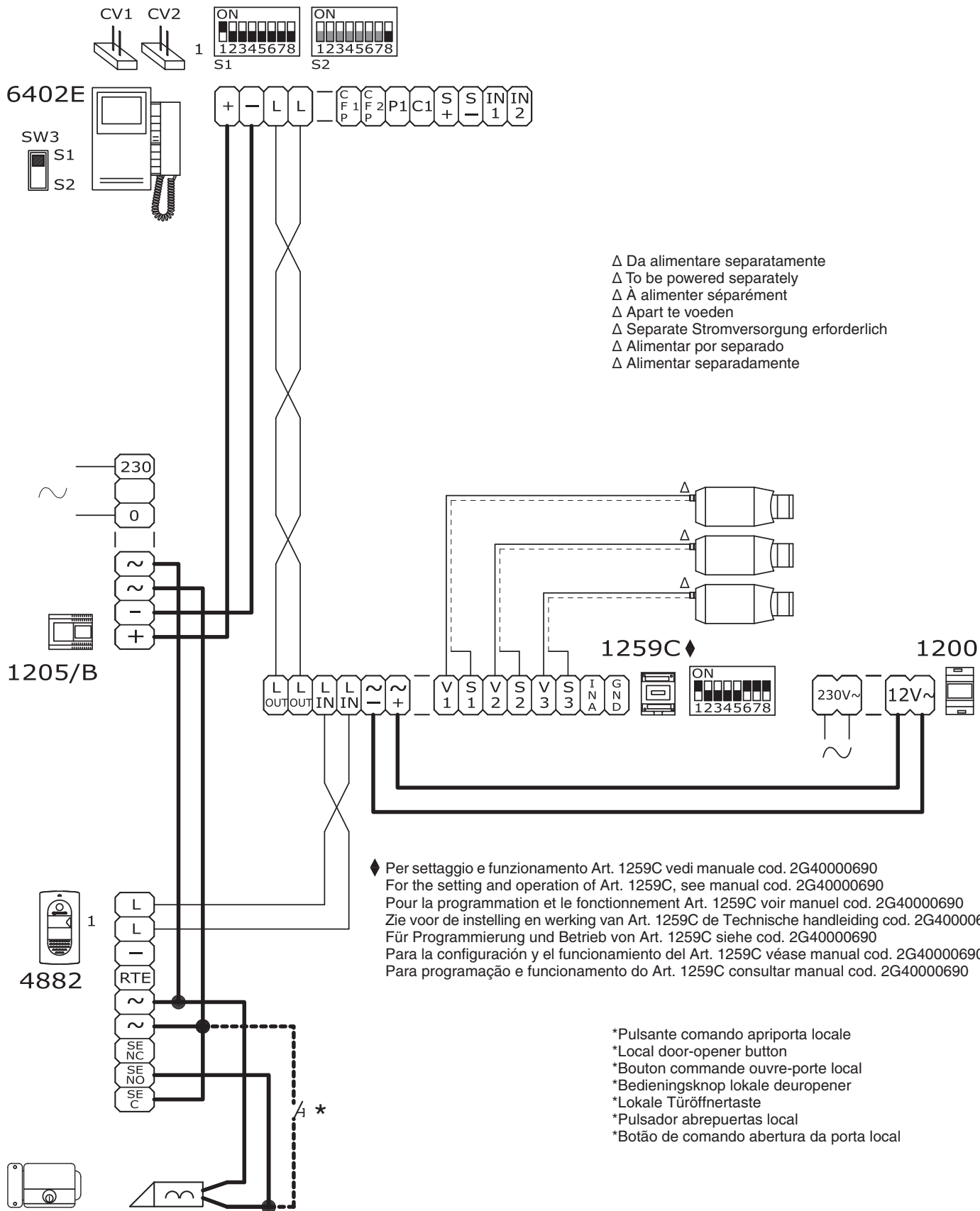

Δ Da alimentare separatamente
 Δ To be powered separately
 Δ À alimenter séparément
 Δ Apart te voeden
 Δ Separate Stromversorgung erforderlich
 Δ Alimentar por separado
 Δ Alimentar separatamente

◆ Per settaggio e funzionamento Art. 1259C vedi manuale cod. 2G40000690
 For the setting and operation of Art. 1259C, see manual cod. 2G40000690
 Pour la programmation et le fonctionnement Art. 1259C voir manuel cod. 2G40000690
 Zie voor de instelling en werking van Art. 1259C de Technische handleiding cod. 2G40000690
 Für Programmierung und Betrieb von Art. 1259C siehe cod. 2G40000690
 Para la configuración y el funcionamiento del Art. 1259C véase manual cod. 2G40000690
 Para programação e funcionamento do Art. 1259C consultar manual cod. 2G40000690

*Pulsante comando apriporta locale
 *Local door-opener button
 *Bouton commande ouvre-porte local
 *Bedieningsknop lokale deuropener
 *Lokale Türöffnertaste
 *Pulsador abrepuertas local
 *Botão de comando abertura da porta local

SB2/AAR

- Ⓘ Collegamento amplificatore video Art. 4833C
- Ⓔ Connection of video amplifier Art. 4833C
- Ⓕ Connexion amplificateur vidéo Art. 4833C
- Ⓝ Aansluiting van de videoversterker Art. 4833C

- Ⓓ Anschluss Videosignalverstärker Art. 4833C
- Ⓔ Conexión del amplificador vídeo Art. 4833C
- Ⓕ Ligação do amplificador vídeo Art. 4833C

LINEA MONTANTE
 RISER LINE
 LIGNE MONTANT
 KABEL STAMLEIDING
 STEIGLEITUNG
 LÍNEA COLUMNA MONTANTE
 LINHA COLUNA

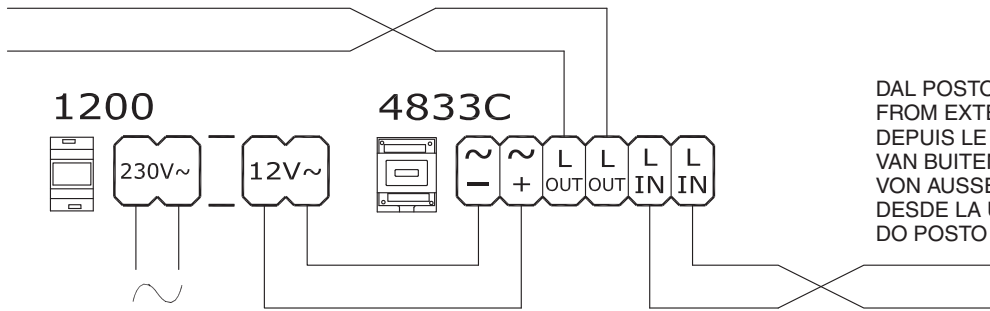

DAL POSTO ESTERNO
 FROM EXTERNAL UNIT
 DEPUIS LE POSTE EXTÉRIEUR
 VAN BUITENPOST
 VON AUSSENSTELLE
 DESDE LA UNIDAD EXTERNA
 DO POSTO EXTERNO

MSK/HCA

- Ⓘ Aggiunta di un monitor principale in parallelo. Collegamento in cascata
- Ⓔ Addition of a main monitor in parallel. Cascade connection
- Ⓕ Adjonction d'un moniteur principal en parallèle. Connexion en cascade
- Ⓝ Toevoeging van een hoofdmonitor in parallelschakeling. Aansluiting in cascade
- Ⓓ Zusätzliche Installation eines Hauptmonitors in Parallelschaltung, Kaskadenverbindung
- Ⓔ Adición de un monitor principal en paralelo. Conexión en cascada
- Ⓕ Adição de um monitor principal em paralelo. Ligação em cascata

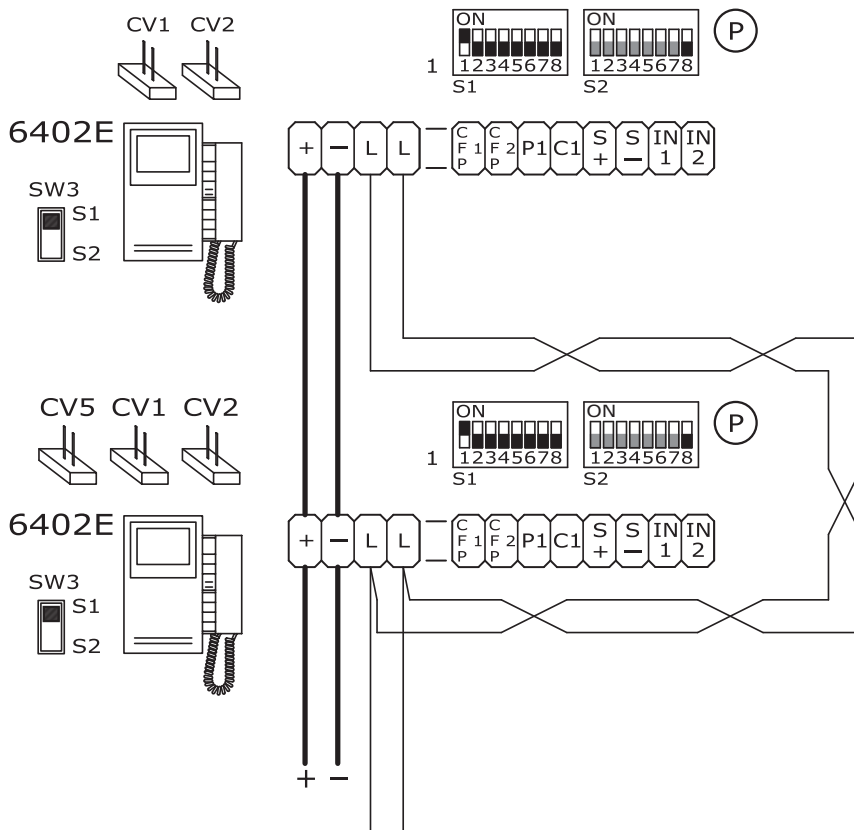

MSK/IC

- (IT) Aggiunta di un monitor principale in parallelo. Collegamento in derivazione
- (EN) Addition of a main monitor in parallel. Branch connection
- (FR) Adjonction d'un moniteur principal en parallèle. Connexion en dérivation
- (NL) Toevoeging van een hoofdmonitor. Afgetakte aansluiting
- (DE) Zusätzliche Installation eines Hauptmonitors in Parallelschaltung, Abzweigverbindung
- (ES) Adición de un monitor principal en paralelo. Conexión en derivación
- (PT) Adição de um monitor principal em paralelo. Ligaçao em derivação

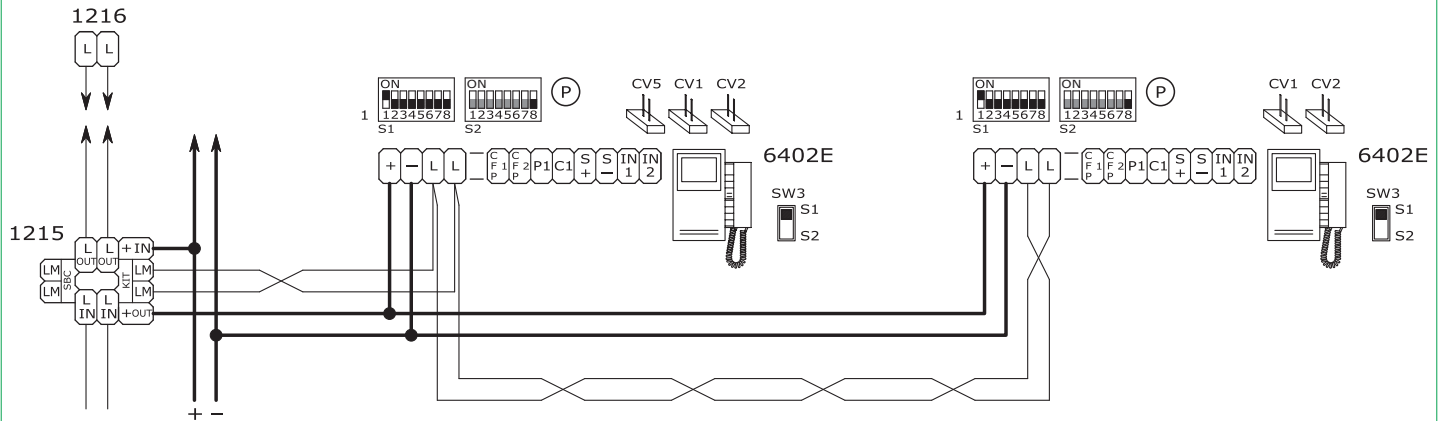

MSK/A20S

- (IT) Collegamento in cascata del terzo monitor principale con alimentazione locale
- (EN) Cascade connection of third main monitor with local power supply
- (FR) Connexion en cascade du troisième moniteur principal avec alimentation locale
- (NL) Aansluiting in cascade van een derde hoofdmonitor met individuele voeding
- (DE) Anschluss in Kaskadenschaltung des dritten Hauptmonitors mit lokaler Stromversorgung
- (ES) Conexión en cascada del tercer monitor principal con alimentación local
- (PT) Ligaçao em cascata do terceiro monitor principal com alimentação local

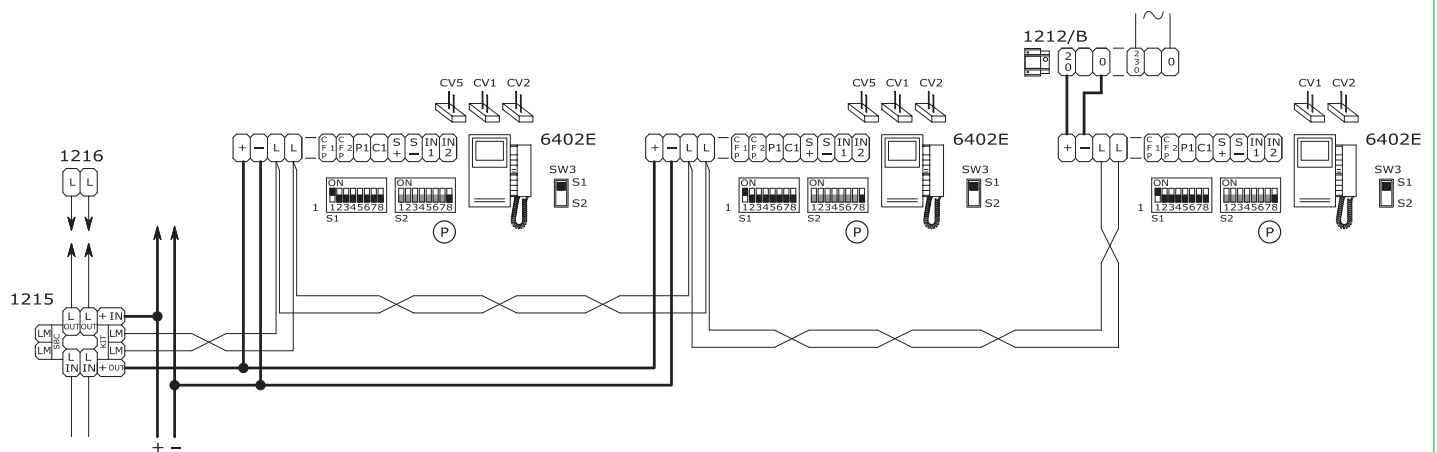

MSK/A23S

- (IT) Collegamento in derivazione di 2 monitor principali e di 2 monitor secondari con lo stesso codice utente
- (EN) Branch connection of 2 main monitors and 2 secondary monitors with the same user code
- (FR) Connexion en dérivation de 2 moniteurs principaux et de 2 moniteurs secondaires avec le même code usager
- (NL) Afgetakte aansluiting van 2 hoofdmonitors en 2 secundaire monitors met dezelfde gebruikerscode
- (DE) Anschluss über Abzweigung von 2 Hauptmonitoren und 2 Zusatzmonitor mit identischem Teilnehmercode
- (ES) Conexión en derivación de 2 monitores principales y 2 monitores secundarias con el mismo código de usuario
- (PT) Ligação em derivação de 2 monitores principais e de 2 monitores secundárias com o mesmo código de utilizador

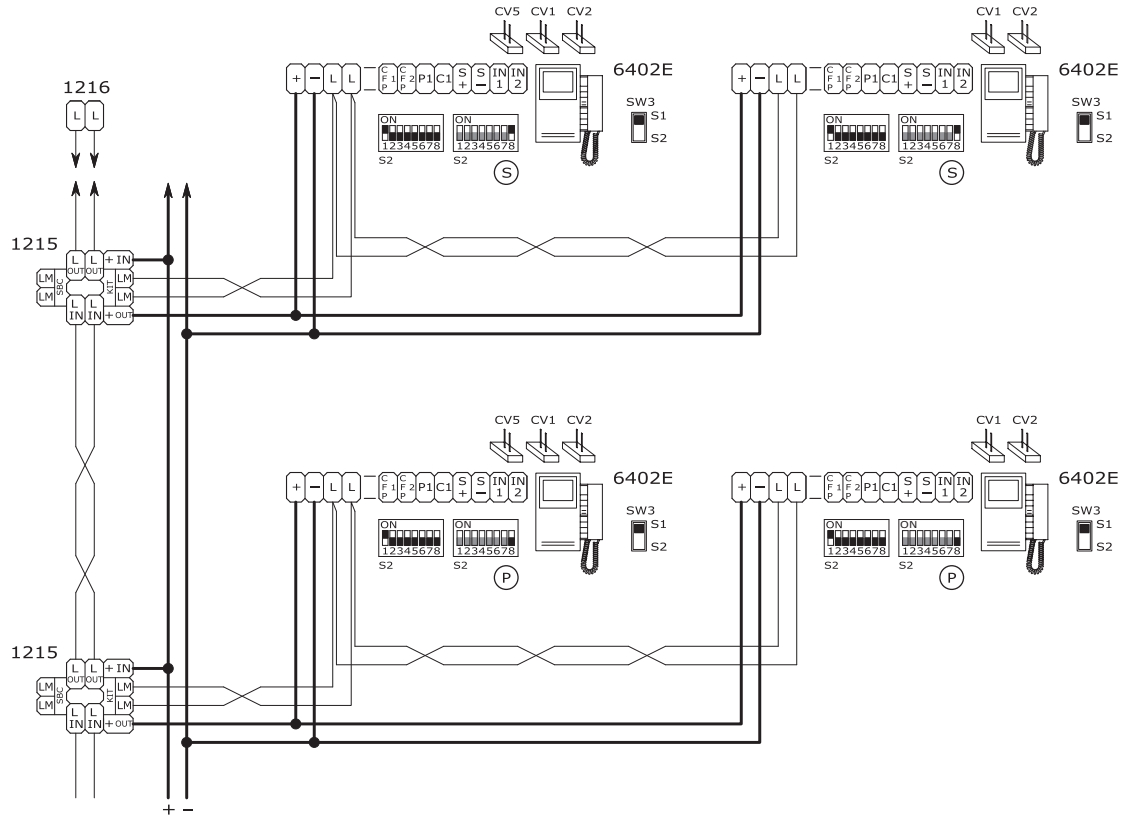

MSK/A21S

- (IT) Collegamento in cascata di 2 monitor principali e di 1 monitor secondario con lo stesso codice utente
- (EN) Cascade connection of 2 main monitors and 1 secondary monitor with the same user code
- (FR) Connexion en cascade de 2 moniteurs principaux et de 1 moniteur secondaire avec le même code usager
- (NL) Aansluiting in cascade van 2 hoofdmonitors en 1 secundaire monitor met dezelfde gebruikerscode
- (DE) Anschluss über Abzweigung von 2 Hauptmonitoren und 1 Zusatzmonitor mit identischem Teilnehmercode
- (ES) Conexión en cascada de 2 monitores principales y 1 monitor secundario con el mismo código de usuario
- (PT) Ligação em cascata de 2 monitores principais e de 1 monitor secundário com o mesmo código de utilizador

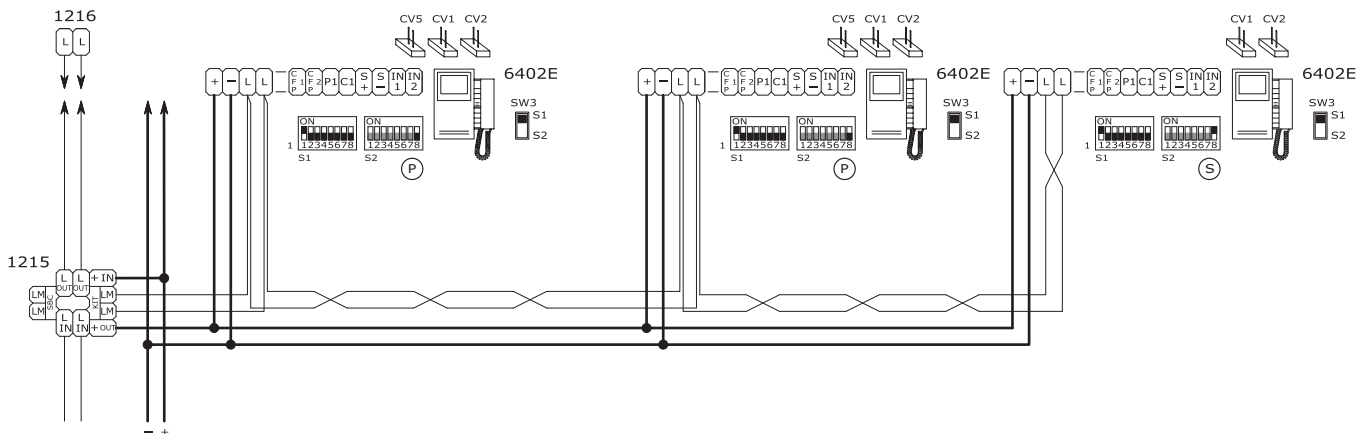

MSK/AAE

- (IT) Collegamento citofoni aggiuntivi in derivazione dal monitor
- (EN) Connection of additional door-entry phones with branch connection from monitor
- (FR) Connexion combinés parlophoniques supplémentaires en dérivation du moniteur
- (NL) Aansluiting van extra deurtelefoons afgetakt van de monitor
- (DE) Anschluss zusätzlicher Sprechstellen mit Abzweigung vom Monitor
- (ES) Conexión de telefonillos adicionales en derivación desde el monitor
- (PT) Ligação de telefones intercomunicadores suplementares em derivação do monitor

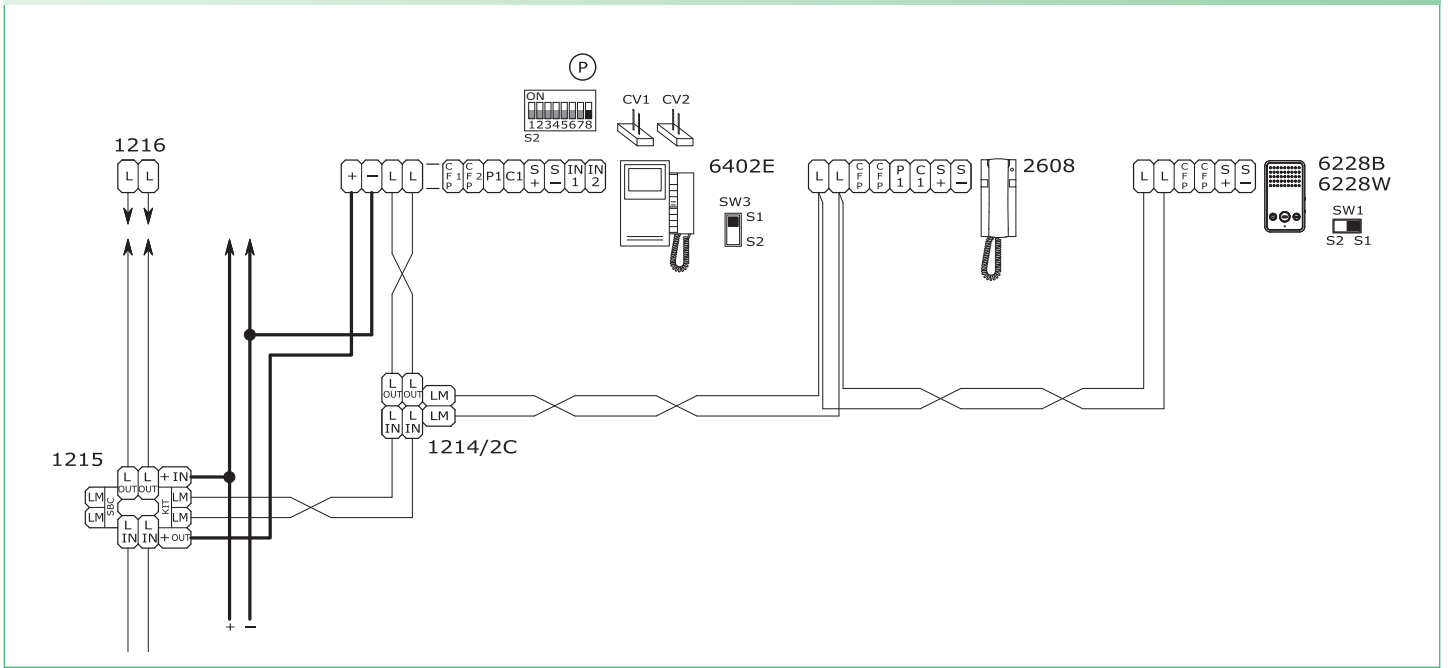

MSK/AAD

- (IT) Collegamento citofoni aggiuntivi in cascata dal monitor
- (EN) Connection of additional door-entry phones with cascade connection from monitor
- (FR) Connexion combinés parlophoniques supplémentaires en cascade du moniteur
- (NL) Aansluiting in cascade van extra deurtelefoons vanaf de monitor
- (DE) Anschluss zusätzlicher Sprechstellen in Kaskadenschaltung vom Monitor
- (ES) Conexión de telefonillos adicionales en cascada desde el monitor
- (PT) Ligação de telefones intercomunicadores suplementares em cascata do monitor

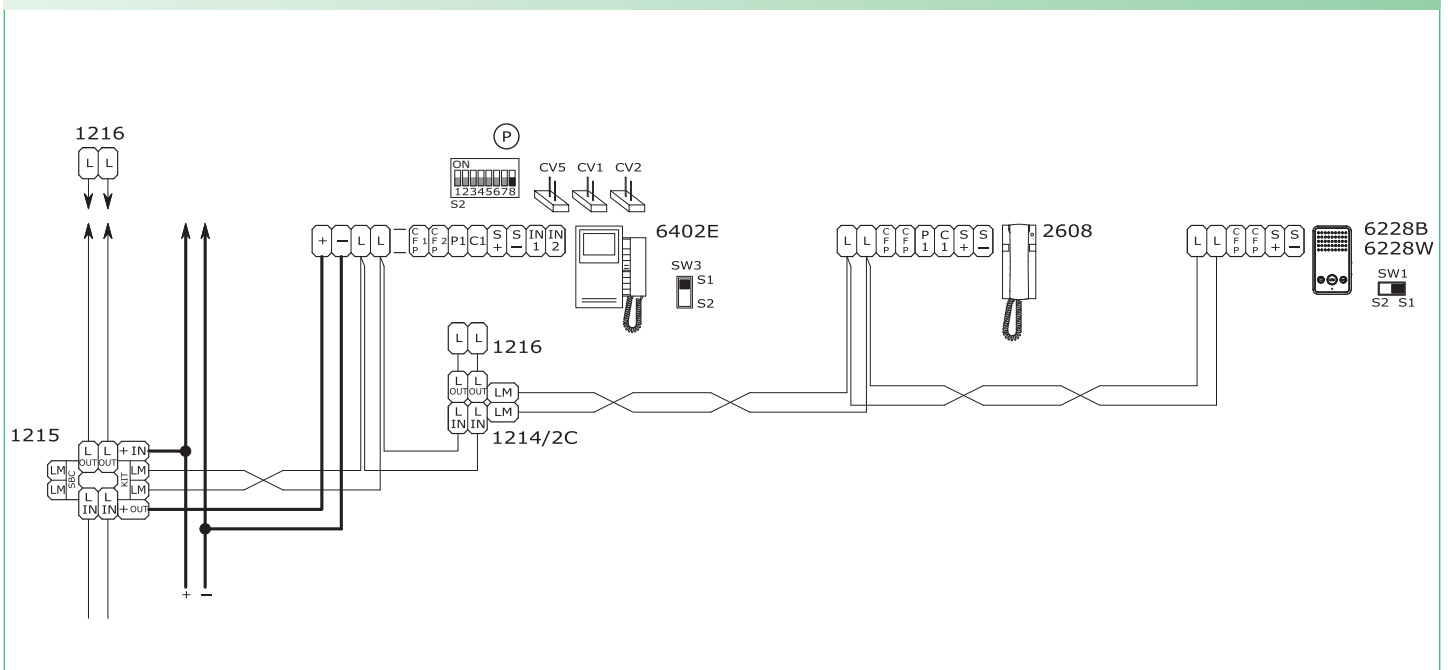

MSK/FC

- Ⓘ Aggiunta di un citofono in parallelo in derivazione dal montante
- Ⓔ Addition of a parallel door-entry phone, with branch connection from riser
- Ⓕ Adjonction d'un combiné parlophonique en parallèle en dérivation du montant
- Ⓖ Aansluiting in cascade van extra deurtelefoons vanaf de monitor
- Ⓗ Anschluss zusätzlicher Sprechstellen in Kaskadenschaltung vom Monitor
- Ⓘ Conexión de telefonillos adicionales en cascada desde el monitor
- Ⓟ Ligação de telefones intercomunicadores suplementares em cascata do monitor

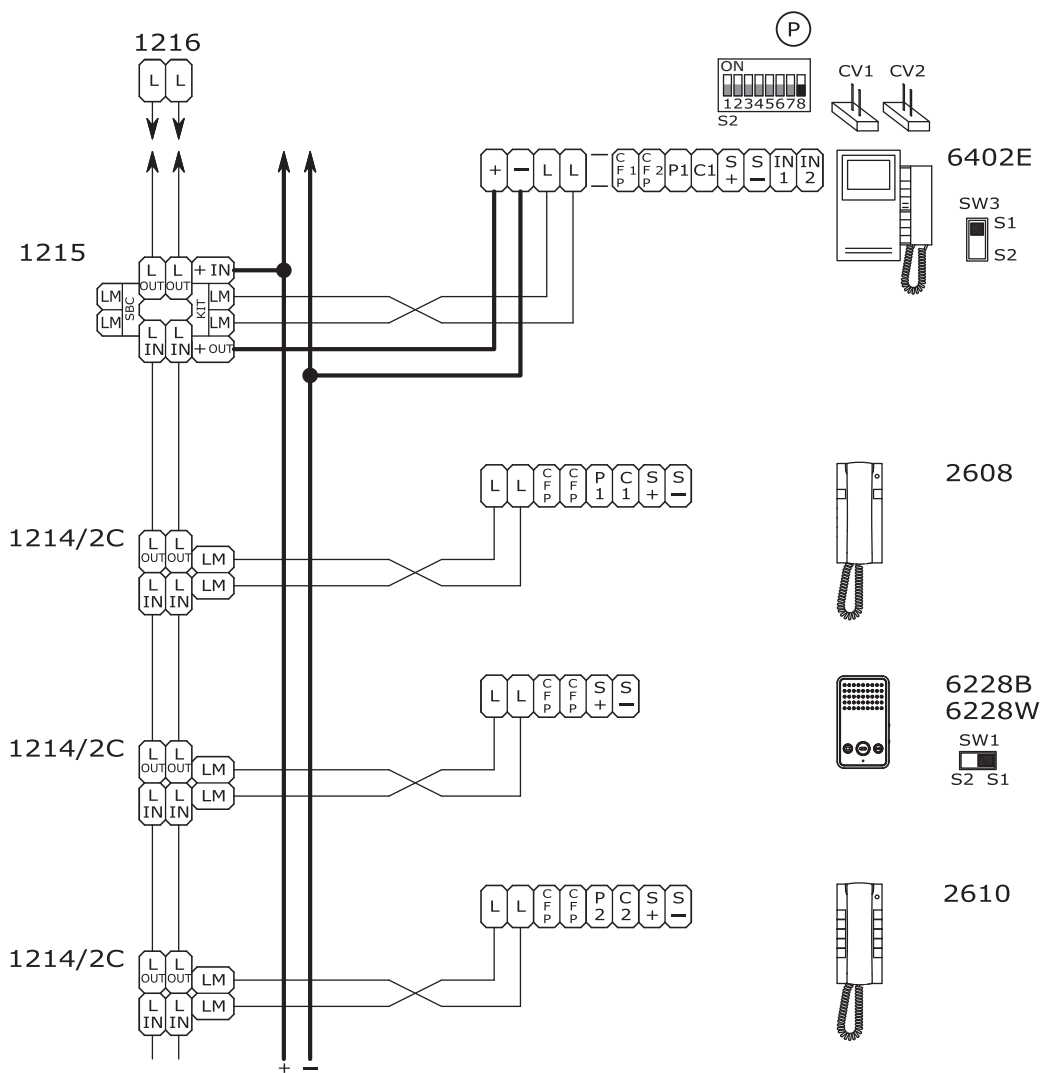

SB/X3

- Ⓘ Utilizzo per usi vari del pulsante P1 (Art. 2608)
- Ⓗ Verwendung von Taste P1 für sonstige Funktionen (Art. 2608)
- Ⓔ Use for various purposes of button P1 (Art. 2608)
- Ⓘ Pulsador P1 para varios usos (Art. 2608)
- Ⓕ Utilisation pour usages divers du bouton P1 (Art. 2608)
- Ⓟ Utilização do botão P1 para vários usos (Art. 2608)
- Ⓖ Gebruik voor verschillende doeleinden van drukknop P1 (Art. 2608)

Rimuovere i jumper CV1 e CV2
 Remove jumpers CV1 and CV2
 Enlever les cavaliers CV1 et CV2
 Verwijder de jumpers CV1 en CV2
 Jumper CV1 und CV2 entfernen
 Quitar los puentes CV1 y CV2
 Retirar os comutadores de derivação CV1 e CV2

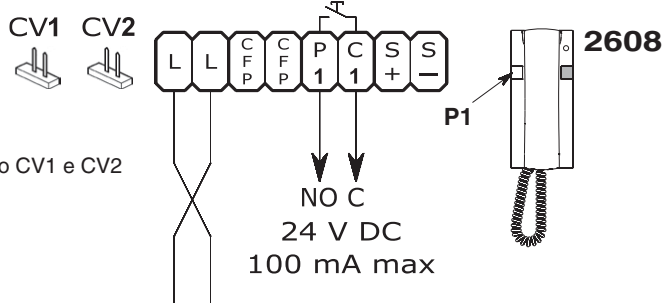

- IT** Connessione di dispositivi di ripetizione di chiamata (Art. 1229 o Art. 1122/A)
- EN** Connection of call repetition devices (Art. 1229 or Art. 1122/A)
- FR** Connexion de dispositifs de répétition d'appel (Art. 1229 ou Art. 1122/A)
- NL** Aansluiting van een extra bel (Art. 1229 of Art. 1122/A)
- DE** Anschluss von Rufwiederholeinrichtungen (Art. 1229 bzw. Art. 1122/A)
- ES** Conexión de dispositivos de repetición de llamada (Art. 1229 o Art. 1122/A)
- PT** Ligação de dispositivos de repetição da chamada (Art. 1229 ou Art. 1122/A)

- IT** La somma totale del numero di posti interni con stesso codice utente **non può superare il numero di 3**. Connettere un solo dispositivo di ripetizione di chiamata per ogni codice utente. In caso di connessione di carichi induttivi si consiglia l'inserimento di una capacità di 470nF in parallelo ai contatti C-NO dell'Art. 1122/A.
- EN** The total number of internal units with the same user code **cannot exceed 3**. Connect only one call repetition device for each user code. If inductive loads are connected, the insertion of a 470nF capacitor in parallel with the C-NO contacts of Art. 1122/A is recommended.
- FR** La somme totale du nombre de postes intérieurs avec le même code utilisateur **ne peut pas dépasser 3**. Brancher un seul dispositif de répétition d'appel pour chaque code utilisateur. En cas de connexion de charges inductives, il est conseillé d'installer une capacité de 470nF en parallèle aux contacts C-NO de l'Art. 1122/A.
- NL** Het totale aantal interne aansluitingen met dezelfde gebruikerscode **mag niet meer zijn dan 3**. Sluit één extra bel aan per gebruikerscode. Bij het aansluiten van inductieve belastingen wordt aangeraden een condensator van 470nF parallel met de C-NO-contacten van Art. 1122/A te plaatsen.
- DE** Die Gesamtanzahl der Innensprechstellen mit dem gleichen Benutzercode **darf nicht höher als 3 sein**. Jeweils nur eine Rufwiederholeinrichtung pro Benutzercode anschließen. Im Fall des Anschlusses von induktiven Lasten empfiehlt sich die Verbindung mit einer Kapazität von 470nF in Parallelschaltung zu den C-NO Kontakten des Art. 1122/A.
- ES** Las unidades internas totales con el mismo código de usuario **no pueden ser más de 3**. Conectar un único dispositivo de repetición de llamada para cada código de usuario. En caso de conexión de cargas inductivas es aconsejable la conexión de una capacidad de 470nF en paralelo a los contactos C-NO del Art. 1122/A.
- PT** A soma total do número de postos internos com o mesmo código de utilizador **não pode ser superior a 3**. Ligar apenas um dispositivo de repetição de chamada para cada código de utilizador. Em caso de conexão de cargas indutivas aconselha-se a introdução de uma resistência de 470 nF em paralelo aos contactos C-NO do Art.1122/A.

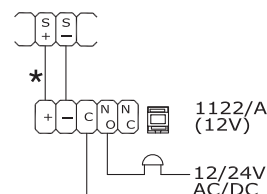
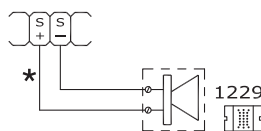

- IT** Variante collegamento chiamata fuori porta
- EN** Floor door call connection variant
- FR** Variante connexion appel palier
- NL** Variant met aansluiting van een etagebel

- IT** In caso di più citofoni o staffe monitor con lo stesso codice utente collegare il pulsante CFP su uno solo; tutti i dispositivi suoneranno contemporaneamente.
- EN** If there are a number of door-entry phones or monitor brackets with the same user code, connect the CFP button to one only; all the devices will ring simultaneously.
- FR** En cas de plusieurs combinés parlophoniques ou étriers moniteur avec le même code usager, relier le bouton CFP sur un seul ; tous les dispositifs sonneront en même temps.
- NL** Sluit bij meerdere deurtelefoons of grondplaten met dezelfde gebruikerscode de drukknoop CFP op slechts één ervan aan; alle toestellen gaan dan tegelijk over.
- DE** Im Fall mehrerer Sprechstellen oder Monitor-Grundplatten mit gleichem Teilnehmercode die CFP-Taste nur an ein Gerät anschließen; daraufhin ertönt an allen Geräten gleichzeitig der Rufton.
- ES** En caso de varios telefonillos o placas soporte de monitor con el mismo código de usuario, conectar el pulsador CFP a uno sólo; todos los dispositivos se activarán al mismo tiempo.
- PT** No caso de vários telefones intercomunicadores ou suportes de monitor com o mesmo código de utilizador, ligar o botão CFP num só; todos os dispositivos soarão em simultâneo.

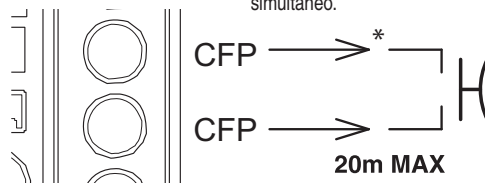

- IT** * **20 m MAX** - Utilizzare cavo schermato per il collegamento e non far passare i cavi in prossimità di carichi induttivi pesanti o cavi di alimentazione (230V / 400V).
- EN** * **20 m MAX** - Use screened cable for the connection and do not run cables near heavy inductive loads or power supply cables (230V / 400V).
- FR** * **20 m MAX** - Pour la connexion, utiliser un câble blindé et ne pas faire passer les câbles à proximité de charges inductives lourdes ou de câbles d'alimentation (230 V / 400 V).
- NL** * **20 m MAX** - Gebruik een afgeschermde kabel voor deze verbinding en leid de kabels niet in de nabijheid van hoge inductieve belastingen of netvoedingskabels (230 V / 400 V).
- DE** * **20 m MAX** - Für den Anschluss abgeschirmte Kabel verwenden und die Kabel nicht in der Nähe von großen induktiven Lasten oder Stromversorgungskabeln (230V / 400V) verlegen.
- ES** * **20 m MAX** - Utilizar cable blindado para la conexión y no tender los cables cerca de cargas inductivas pesadas o cables de alimentación (230V / 400V).
- PT** * **20 m MAX** - Utilizar cabo blindado para a ligação e não fazer passar os cabos nas proximidades de cargas indutivas pesadas ou de cabos de alimentação (230V / 400V).

- Ⓜ Utilizzo ingresso IN1 come contatto per segnalazione LED/ALLARME/APRIPORTA/ATTUATORE. Attivazione in chiusura verso CFP2
- Ⓝ Using IN1 input for LED/ALARM/LOCK-RELEASE/ACTUATOR indication. Activation on closure towards CFP2
- Ⓡ Utilisation de l'entrée IN1 comme contact pour signal LED/ALARME/OUVRE-PORTE/ACTIONNEUR. Activation en fermeture vers CFP2
- Ⓝ Gebruik ingang IN1 als contact voor signalering LED/ALARM/DEUROPENER/RELAIS. Activering bij sluiting naar CFP2
- Ⓝ Verwendung des Eingangs IN1 als Meldekontakt LED/ALARM/TÜRÖFFNER/RELAIS. Aktivierung bei Schließen des Kontakts zwischen IN1 und CFP2
- Ⓝ Uso de la entrada IN1 como contacto para señalización de LED/ALARMA/ABREPUERTAS/ACTUADOR. Se activa al cerrar el contacto con CFP2
- Ⓝ Utilização da entrada IN1 como contacto para a indicação LUZ INDICADORA/ALARME/ABERTURA DA PORTA/ACTUADOR. Activação perante fecho entre IN1 e CFP2

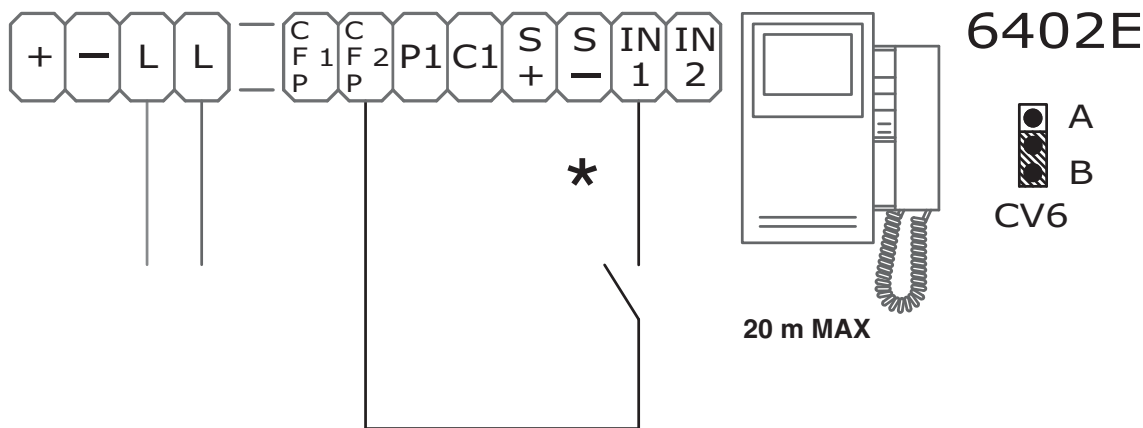

- Ⓜ Utilizzo ingresso IN1 come contatto per segnalazione LED/ALLARME/APRIPORTA/ATTUATORE. Attivazione in presenza di tensione rispetto a IN2
- Ⓝ Using IN1 input for LED/ALARM/LOCK-RELEASE/ACTUATOR indication. Activation in the presence of voltage in relation to IN2
- Ⓡ Utilisation de l'entrée IN1 comme contact pour signal LED/ALARME/OUVRE-PORTE/ACTIONNEUR. Activation en présence de tension par rapport à IN2
- Ⓝ Gebruik ingang IN1 als contact voor signalering LED/ALARM/DEUROPENER/RELAIS. Activering bij aanwezigheid van spanning ten opzichte van IN
- Ⓝ Verwendung des Eingangs IN1 als Meldekontakt LED/ALARM/TÜRÖFFNER/RELAIS. Aktivierung bei Anliegen von Spannung im gegenüber IN2
- Ⓝ Uso de la entrada IN1 como contacto para señalización de LED/ALARMA/ABREPUERTAS/ACTUADOR. Se activa cuando hay tensión con relación a IN2
- Ⓝ Utilização da entrada IN1 como contacto para a indicação LUZ INDICADORA/ALARME/ABERTURA DA PORTA/ACTUADOR. Activação na presença de tensão comparativamente a IN2

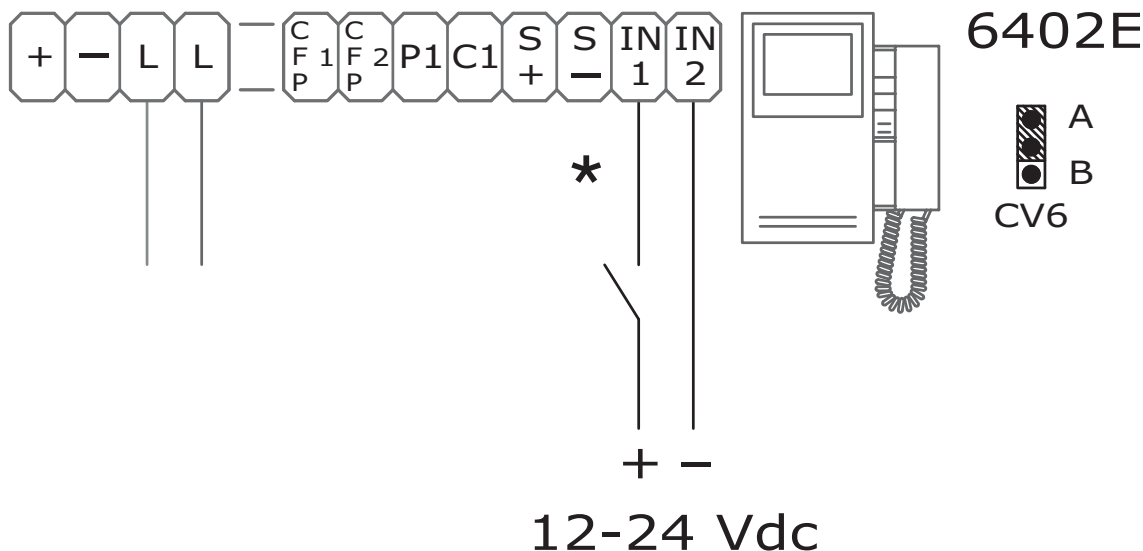

- Ⓜ* Ingresso da programmare, vedi pag. 15
In funzione segnalazione LED il led di segnalazione privacy attiva/impianto occupato lampeggia.
- Ⓝ* Input to be programmed, see page 31
Depending on the LED indication, the privacy active/system busy indication LED flashes.
- Ⓡ* Entrée à programmer, voir page 47
En fonction du signal LED, la led d'indication de privacy active/système occupé clignote.
- Ⓝ* Ingang te programmeren, zie pag. 63
In de functie signalering LED zal de led voor signalering privacy actief/system bezet knipperen.
- Ⓝ* Zu programmierender Eingang, siehe Seite 79
Wenn die LED-Meldefunktion aktiv ist, blinkt die LED-Anzeige für Privacy-Funktion aktiv/Anlage besetzt.
- Ⓝ* Entrada por programar, véase pág. 95
Programada para la señalización de led, el led correspondiente parpadea para indicar que la función privacidad está activada o la instalación ocupada.
- Ⓝ* Entrada a programar, consultar a pág. 111
Com a indicação luz indicadora activada, a luz indicadora de indicação de privacidade activada/instalação ocupada pisca.

SB2/AAM2

- | | |
|--|--|
| IT Utilizzo per usi vari del pulsante P1 | DE Verwendung von Taste P1 für sonstige Funktionen |
| EN Use for various purposes of button P1 | ES Pulsador P1 para varios usos |
| FR Utilisation pour usages divers du bouton P1 | PT Utilização do botão P1 para vários usos |
| NL Gebruik voor verschillende doeleinden van drukknop P1 | |

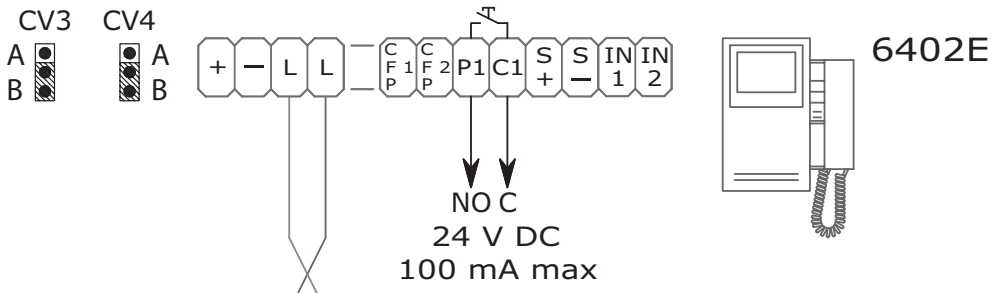

Per avere un contatto C.NO. (24V-100mA max) spostare in posizione B i jumper CV3 e CV4.
 To have a C.NO. contact (24 V-100 mA max.), move jumpers CV3 and CV4. to position B.
 Pour avoir un contact C.NO. (24V-100mA maxi), déplacer les cavaliers CV3 et CV4 sur la position B.
 Voor een C.NO.-contact (max. 24V-100mA) zet u de jumpers CV3 en CV4 op stand B.
 Zur Herstellung eines Schließerkontakts (max. 24V - 100mA) die Stecker CV3 und CV4 in Stellung B versetzen.
 Para obtener un contacto normalmente abierto (24 V - 100 mA máx.) poner los puentes CV3 y CV4 en posición B.
 Para obter um contacto C.NO. (24 V-100 mA máx.) colocar os comutadores de derivação CV3 e CV4 na posição B.

SMK/EC

- | | |
|---|---|
| IT Collegamento relé attuatore Art. 1256 | DE Anschluss Relais Art. 1256 |
| EN Connecting actuator relay Art. 1256 | ES Conexión del relé actuador Art. 1256 |
| FR Branchement relais actionneur Art.1256 | PT Ligação do relé actuador Art. 1256 |
| NL Aansluiting relais module Art. 1256 | |

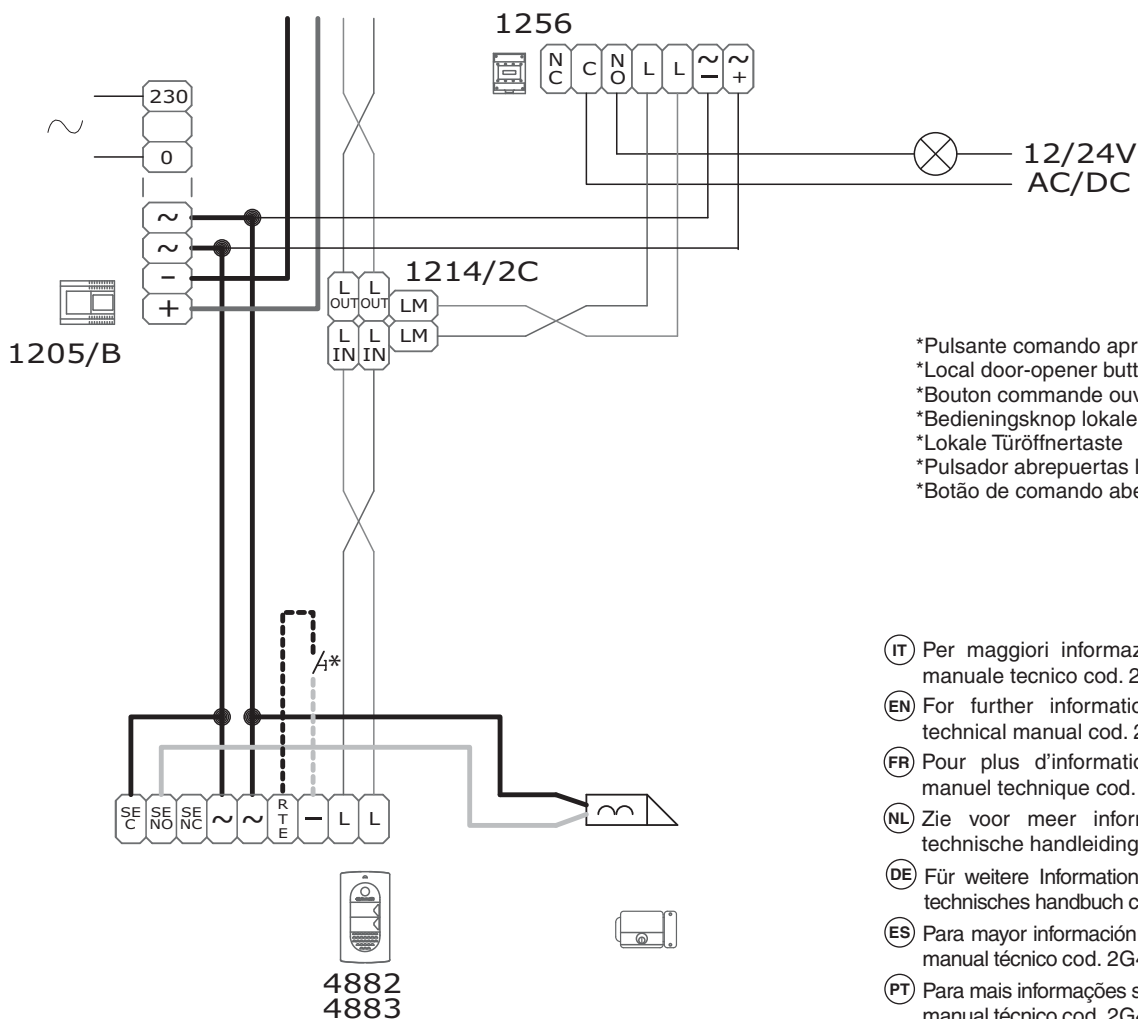

- *Pulsante comando apertura locale
- *Local door-opener button
- *Bouton commande ouvre-porte local
- *Bedieningsknop lokale deuropener
- *Lokale Türöffnertaste
- *Pulsador abrepuertas local
- *Botão de comando abertura da porta local

- | |
|--|
| IT Per maggiori informazioni su Art. 1256 vedi manuale tecnico cod. 2G40000687 |
| EN For further information on Art. 1256, see technical manual cod. 2G40000687 |
| FR Pour plus d'informations sur l'Art.1256 voir manuel technique cod. 2G40000687 |
| NL Zie voor meer informatie over Art. 1256, technische handleiding cod. 2G40000687 |
| DE Für weitere Informationen über Art. 1256 siehe technisches handbuch cod. 2G40000687 |
| ES Para mayor información sobre el Art. 1256, véase manual técnico cod. 2G40000687 |
| PT Para mais informações sobre o Art. 1256, consultar manual técnico cod. 2G40000687 |

GK/AAGC

- (IT) Variante collegamento apriporta locale temporizzato
- (EN) Variant to connect the timed local lock button (request to exit)
- (FR) Variante pour connecter le bouton de commande de gâche local temporisé
- (NL) Variant voor het aansluiten van een lokale deuropener met tijdsinstelling
- (DE) Variante mit Anschluss der zeitgesteuerten lokalen Türöffnertaste
- (ES) Variante con conexión abrepuertas local temporizado
- (PT) Variante de ligação da abertura da porta local com tempo programado

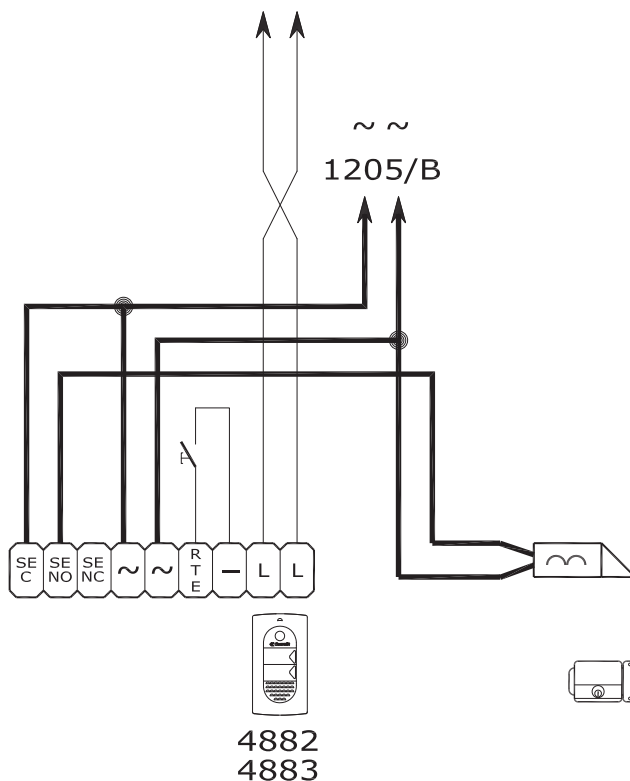

SMK/SNP

- (IT) Variante con serratura di sicurezza e alimentazione aggiuntiva
- (EN) Variant with security door lock and additional power supply
- (FR) Variante avec gâche de sécurité et alimentation supplémentaire
- (NL) Variant met veiligheidsslot en extra voeding
- (DE) Variante mit Sicherheits-Türöffner und zusätzlicher Stromversorgung
- (ES) Variante con cerradura de seguridad y alimentación adicional
- (PT) Variante com fechadura de segurança e alimentação suplementar

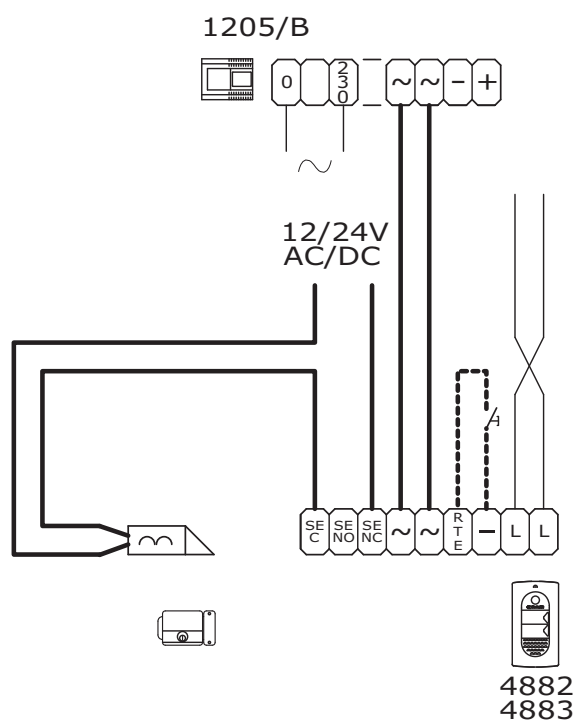

- Ⓘ Utilizzo della rete RC per filtro serratura sui contatti del relè
- Ⓔ Using the RC network for door lock filter on relay contacts
- Ⓕ Utilisation du réseau RC pour filtre gâche sur les contacts du relais
- Ⓖ Gebruik van het RC-net voor storingsfilter op de contacten van het relais
- Ⓓ Verwendung des RC-Glieds als Türöffner-Filter an den Relaiskontakten
- Ⓔ Uso de la red RC para el filtro de la cerradura en los contactos del relé
- Ⓗ Utilização da rede RC para filtrar a fechadura nos contactos do relé

Sui contatti C. NO.
 On contacts C. NO.
 Sur les contacts C. NO.
 Op de C. NO-contacten.
 An den Schließerkontakten
 En los contactos normalmente abiertos
 Nos contactos C. NO.

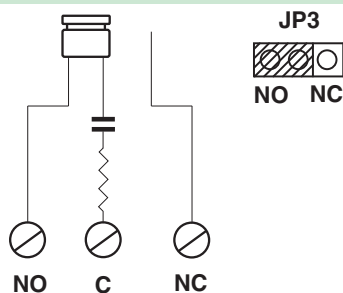

Sui contatti C. NC.
 On contacts C. NC.
 Sur les contacts C. NC.
 Op de C. NC-contacten.
 An den Schließerkontakt
 En los contactos normalmente cerrado
 Nos contactos C. NC.

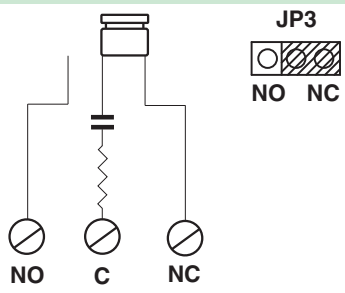

Esclusa: contatto pulito
 Disabled: clean contact
 Exclue : contact libre
 Met uitzondering van: potentiaalvrij contact
 Ausgenommen: potentialfreier Kontakt
 Excluido: contacto libre de potencial
 Exclusão: contacto limpo

