

NOTE:
THIS DRAWING INDICATES AND ASSUMES THE USE OF
A MINIMUM OF 0.5MM CSA PER CORE.

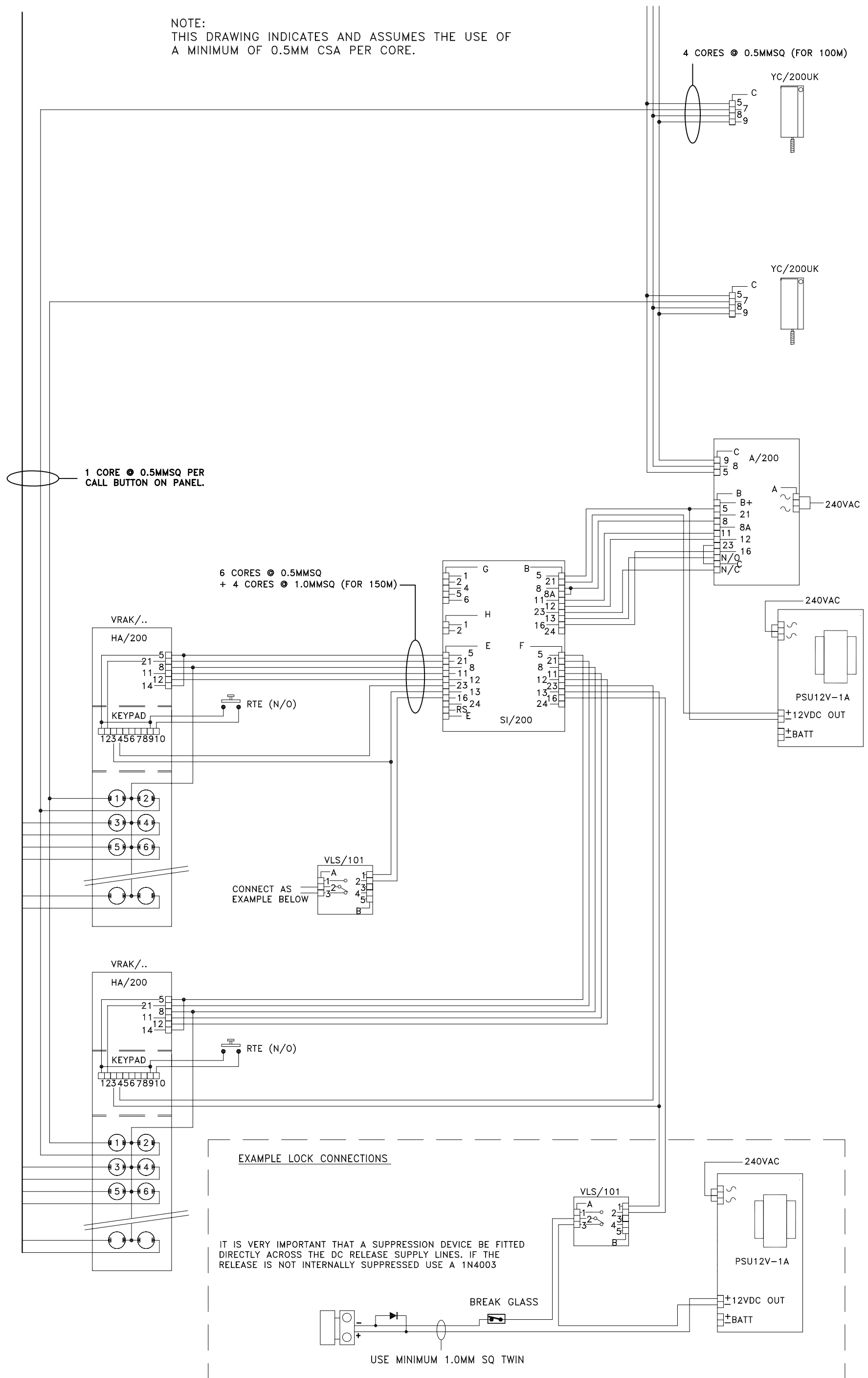

| | | | |
|---------------------------------|--|-----------------------|-----------|
| BPT (UK) LTD. HERTS. ENGLAND | PREPARED FOR INSTALLER INFORMATION | DATE: 29/04/04 | DRAWN: RC |
| DRAWING TITLE: | 2 x MULTI-BUTTON VR AUDIO ENTRY PANELS WITH KEYPADS & MAGLOCKS CALLING LYNEA HANDSETS | REVISED: | |
| | | DRAWING No: E-NV2YNUK | |