

NOTE:  
ENSURE THAT THE CORRECT DIP SWITCHES ARE SET AND THAT THE IT/200 IS PROGRAMED AS PER ITS MANUAL. (IE. 29-0, 63-1)

ENSURE THAT THE BT LINE 'IN' IS AN ANALOGUE LINE NOT ISDN.

BT LINE OUT TO DTMF TELEPHONES (5 MAX)

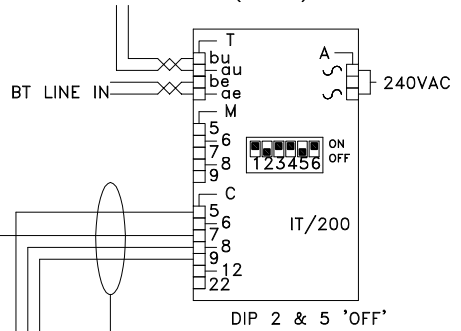

4 CORES @ 0.5MMSQ (FOR 50M)

6 CORES @ 0.5MMSQ  
+ 2 CORES @ 1.0MMSQ (FOR 150M)

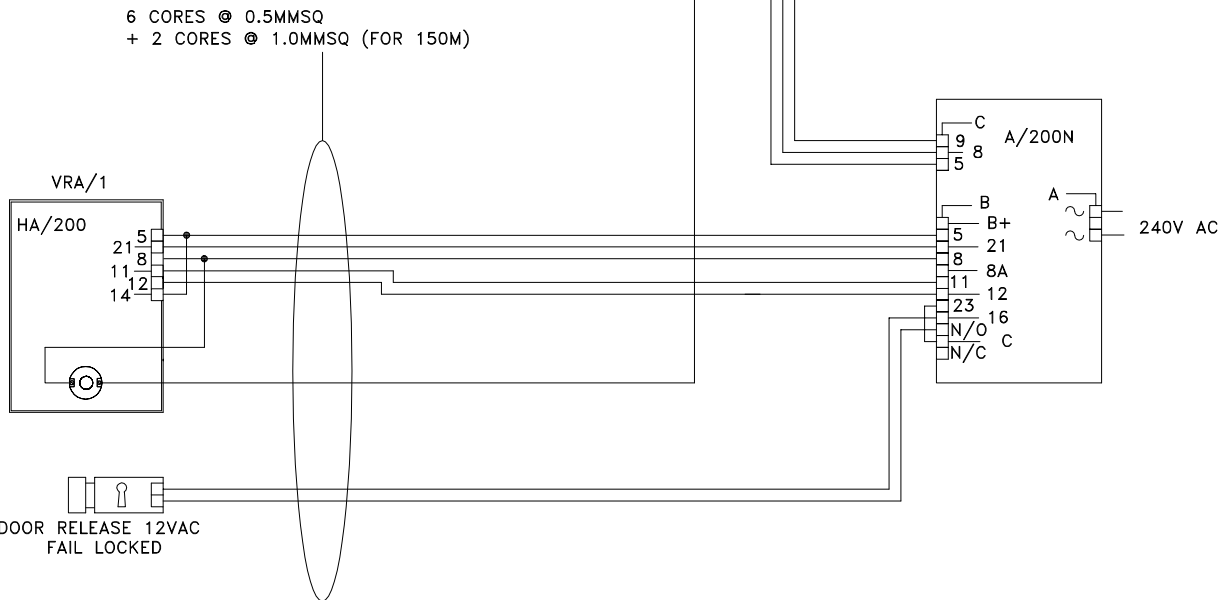

BPT (UK) LTD.  
HERTS. ENGLAND

PREPARED FOR  
INSTALLER INFORMATION

DATE: 04/12/03

DRAWN:RC

REVISED:

DRAWING TITLE:

1 X 1 BUTTON VR AUDIO ENTRY PANEL  
& 1 BT TELEPHONE INTERFACE

DRAWING No: E-1V111L