

IT EN FR
MANUALE TECHNICAL MANUEL
TECNICO MANUAL TECHNIQUE

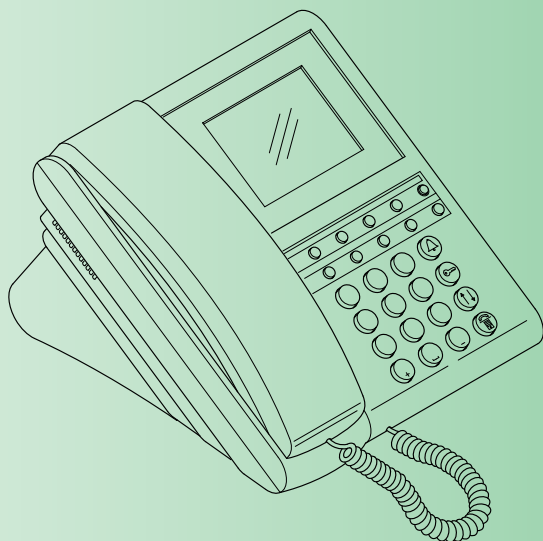

SIMPLE
BUS
TOP

SBC
SIMPLEBUS
COLOR

Video
videochiamata | Comelit

Centralino di portineria Art. 1998V, 1998VC
Porter switchboard Art. 1998V, 1998VC
Standard de conciergerie Art. 1998V, 1998VC

www.comelitgroup.com



 **Comelit**[®]
Passion and Innovation



(IT) Avvertenze

- Effettuare l'installazione seguendo scrupolosamente le istruzioni fornite dal costruttore ed in conformità alle norme vigenti.
- Tutti gli apparecchi devono essere destinati esclusivamente all'uso per cui sono stati concepiti. **Comelit Group S.p.A.** declina ogni responsabilità per un utilizzo improprio degli apparecchi, per modifiche effettuate da altri a qualunque titolo e scopo, per l'uso di accessori e materiali non originali.
- Tutti i prodotti sono conformi alle prescrizioni delle direttive 2006/95/CE (che sostituisce la direttiva 73/23/CEE e successivi emendamenti) e ciò è attestato dalla presenza della marcatura **CE** sugli stessi.
- Evitare di porre i fili di montante in prossimità di cavi di alimentazione (230/400V).
- Gli interventi di installazione, montaggio e assistenza agli apparecchi elettrici devono essere eseguiti esclusivamente da elettricisti specializzati.
- Nell' impianto elettrico dell'edificio deve essere previsto un interruttore di rete onnipolare con un'apertura di contatto di almeno 3mm in grado di sezionare l'alimentazione del dispositivo.
- Togliere l'alimentazione prima di effettuare qualsiasi manutenzione.
- Rimettere le protezioni sui morsetti e chiudere lo sportellino di ispezione dopo ogni intervento.
- Il dispositivo è conforme alla norma EN60950-1 relativa alla sicurezza di apparecchiature per la tecnologia dell'informazione.
- Non tenere premuto il gancio fonica con la cornetta sollevata.

(EN) Warning

- Install the equipment by carefully following the instructions given by the manufacturer and in compliance with the standards in force.
- All the equipment must only be used for the purpose it was designed for. **Comelit Group S.p.A.** declines any responsibility for improper use of the apparatus, for modifications made by third parties for any reason or purpose, and for the use of non-original accessories and materials.
- All the products comply with the requirements of the 2006/95/CE directives (which replace directive 73/23/CEE and subsequent amendments), as certified by the **CE** mark on the products.
- Do not route riser wires in proximity to power supply cables (230/400V).
- Installation, mounting and assistance procedures for electrical devices must only be performed by specialised electricians.
- The electrical system of the building must be fitted with an omnipolar mains switch with a contact opening of at least 3mm, which is capable of isolating the power supply of the device.
- Cut off the power supply before carrying out any maintenance work.
- Place the protection back over the terminals and close the inspection door after every procedure.
- The device conforms to standard EN60950-1 relating to the safety of information technology equipment.
- Do not press and hold the audio hook while the handset is lifted.

(FR) Avertissements

- Effectuer l'installation en suivant scrupuleusement les instructions fournies par le constructeur et conformément aux normes en vigueur.
- Tous les appareils doivent être strictement destinés à l'emploi pour lequel ils ont été conçus. La société **Comelit Group S.p.A.** décline toute responsabilité en cas de mauvais usage des appareils, pour des modifications effectuées par d'autres personnes pour n'importe quelle raison et pour l'utilisation d'accessoires et matériaux non d'origine.
- Tous les produits sont conformes aux prescriptions de la directive 2006/95/CE (qui remplace la directive 73/23/CEE et amendements successifs). Cela est attesté par la présence du marquage **CE** sur les produits.
- Éviter de placer les fils de montant à proximité des câbles d'alimentation (230/400V).
- Les interventions d'installation, de montage et d'assistance aux appareils électriques doivent être effectuées exclusivement par des électriciens spécialisés.
- L'installation électrique du bâtiment doit être munie d'un interrupteur de réseau onnipolaire avec une ouverture de contact d'au moins 3mm en mesure de sectionner l'alimentation du dispositif.
- Couper l'alimentation avant d'effectuer toute opération d'entretien.
- Remettre les protections sur les bornes et fermer la porte d'inspection après chaque intervention.
- Le dispositif est conforme à la norme EN60950-1 relative à la sécurité des équipements pour la technologie de l'information.
- Ne pas maintenir le crochet phonie enfoncé lorsque le combiné est décroché.



SOMMARIO

- INTRODUZIONE

- Vista generale	4
- Descrizione morsetteria	4
- Tasti di programmazione e display	5
- Tastiera alfanumerica	5
- Descrizione generica	5

- UTILIZZO

U1 Come rispondere a una chiamata da posto interno	6
U2 Come rispondere a una chiamata da posto esterno	6
U3 Come chiamare un posto interno	7
U4 Come inoltrare una chiamata da posto esterno a posto interno	8
U5 Come mettere in comunicazione 2 interni tra loro (funzione intercomunicante)	8
U6 Come chiamare un posto interno presente nelle chiamate ricevute	9
U7 Come chiamare un centralino secondario da centralino principale	10
U8 Come chiamare un centralino principale da centralino secondario	11
U9 Come rispondere a una chiamata da centralino secondario a centralino principale	11
U10 Come rispondere a una chiamata da centralino principale a centralino secondario	12
U11 Come attivare o disattivare i centralini principali	12
U12 Come utilizzare l'apriporta	13
U13 Come attivare la funzione "Seguimi" (FollowMe)	13
U14 Come attivare un relé supplementare	13

- RUBRICA

- Albero schermate menu RUBRICA	14
U15 Come utilizzare la rubrica	14
U16 Come cercare un nome in rubrica	14
U17 Come inserire un nome in rubrica	15
U18 Come cancellare un nome in rubrica	15
U19 Come modificare un nome in rubrica	16
U20 Cancellazione rubrica	17
U21 Info rubrica	17
U22 Registrazione numeri brevi	18

- CHIAMATE RICEVUTE

- Albero schermate menu CHIAMATE RICEVUTE	18
U23 Visualizzazione chiamate ricevute	18
U24 Cancellazione lista chiamate ricevute	19

- ALLARMI

- Albero schermate menu ALLARMI	20
U25 Visualizzazione allarmi	20
U26 Cancellazione lista allarmi ricevuti	20

- IMPOSTAZIONI

- Albero schermate menu IMPOSTAZIONI	21
I1 - Modifica lingua	22
I2 - Impostazioni video	22
I3 - Impostazioni audio	23
I4 - Impostazioni suoni	23
I5 - Modifica data	24
I6 - Modifica ora	24
I7 - Impostazione tema	25
I8 - Regolazione tempi (fonica, attesa reset, standby, attivazione relé, ripetizione chiamata)	25
I9 - Impostazione modalità giornaliera	26
I10 - Impostazione commut. automatica	26
I11 - Reset impostazioni	27

- CONFIGURAZIONI INSTALLATORE

- Albero schermate menu CONFIGURAZIONI	28
- C1 - Tipo di centralino (modalità Simplebus Top)	29
- C2 - Come configurare un centralino principale o secondario	30
- C3 - Come configurare un centralino come singolo, parallelo o serie	30
- C4 - Chiamata tramite codice Simplebus o indiretto	31
- C5 - Retrocompatibilità	31
- C6 - Chiamata audio o video	32
- Tabella articoli Simplebus TOP	32
- C7 - Configurazione servizi (FollowMe, ripetizione di chiamata, accensione interni, chiamata tripla, aiuto codici)	33

- SCHEMI DI COLLEGAMENTO

- SB2V/EN/103M Impianto videocitofonico Simplebus b/n con 1 ingresso principale e centralino di portineria.	96
- SB2V/EN/103SMC Impianto videocitofonico Simplebus Color con 1 ingresso principale e centralino di portineria.	97
- SB2V/EN/105M Impianto videocitofonico Simplebus b/n con 2 ingressi principali e centralino di portineria.	98
- SB2V/EN/105SMC Impianto videocitofonico Simplebus Color con 2 ingressi principali e centralino di portineria.	99
- SB2V/018ASMC Impianto Simplebus Color con modulo telecamera scorporata Art. 1259C in modalità attuatore generico e centralino di portineria.	100
- SB2V/026SMC Impianto videocitofonico con 1 ingresso principale e centralino di portineria abbinato al centralino telefonico Art. 2906 per follow-me.	101
- SB2V/EN/101M Impianto videocitofonico Simplebus b/n con 1 ingresso principale, 3 secondari video e centralino di portineria.	102
- SB2V/EN/101SMC Impianto videocitofonico Simplebus Color con 1 ingresso principale, 3 secondari video e centralino di portineria.	104
- SB2V/EN/121DM Impianto videocitofonico Simplebus b/n con 2 ingressi principali, 3 secondari audio e centralino di portineria.	106
- SB2V/EN/121DSMC Impianto videocitofonico Simplebus Color con 2 ingressi principali, 3 secondari audio e centralino di portineria.	108
- SBTOP/001DSMC Impianto videocitofonico Simplebus TOP con 1 ingresso principale, 4 secondari e relativi centralini di portineria secondari.	110
- SBTOP/002DSMC Impianto videocitofonico Simplebus TOP con 2 ingressi principali, 4 secondari e centralino di portineria principale.	112
- SBTOP/003DSMC Impianto videocitofonico Simplebus TOP con 2 ingressi principali, 1 centralino di portineria principale, 2 secondari e relativi centralini di portineria secondari.	114
- SBTOP/004DSMC Impianto videocitofonico Simplebus TOP con 1 ingresso principale, 4 secondari e 2 centralini di portineria principali in configurazione SERIE.	116
- SBTOP/005DSMC Impianto videocitofonico Simplebus TOP con 1 ingresso principale, 3 secondari e 2 centralini di portineria principali in configurazione PARALLELO.	118

Vista generale

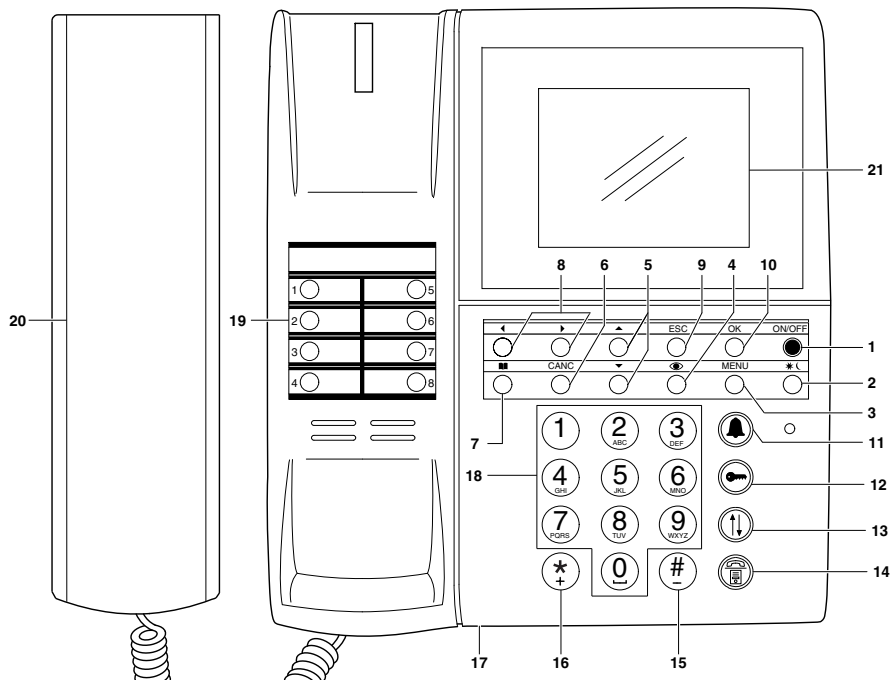

- 1 **ON/OFF** Accensione/spengimento (tenere premuto per 2 secondi)
- 2 *** / ☾** Tasto per attivare la modalità GIORNO o NOTTE
- 3 Tasto **MENU**
- 4 **☉** Tasto per attivare l'autoaccensione
- 5 **▼ / ▲** Tasti per scorrimento menu
- 6 **CANC** Tasto di annullamento chiamata o cancellazione dati inseriti
- 7 **📖** Tasto rubrica
- 8 **◀ / ▶** Tasti per scorrimento opzioni menu
- 9 **ESC** Tasto di uscita dai menu
- 10 **OK** Tasto conferma
- 11 **📞** Tasto per invio chiamata
- 12 **🔇** Tasto per apriporta
- 13 **📞** Tasto per trasferimento di chiamata
- 14 **📞** Tasto per mettere in attesa una chiamata
- 15 **#** Tasto per chiamare il centralino Simplebus Top dal centralino Simplebus
- 16 *** / *** Tasto per attivare un relé supplementare
- 17 Rotella regolazione volume suoneria
- 18 Tastiera alfanumerica
- 19 **○** Numeri brevi
- 20 Cornetta
- 21 Display segnalazione messaggi

Descrizione morsettiere:

- C NO** Contatto normalmente aperto per funzione "SEGUIMI" (Follow me)
- 24 ~** Alimentazione 24V AC
- 0 ~** Alimentazione 0V AC
- ⏚** Messa a terra
- OUT OUT** Contatto normalmente aperto che si chiude inviando una chiamata video dal centralino verso un interno
- CH CH** Contatto libero per "ripetizione di chiamata" o "abilitazione monitor esterno"
- LM LM** Linea dati verso i montanti
- LP1 LP2** Linea dati in arrivo da posto esterno
- GND TX RX** Seriale rs232 da connettere al centralino remoto negli impianti multicentralino in serie o in parallelo.

Tasti di programmazione e display

MENU	Per entrare nei menu di programmazione
▼▲	Permettono di selezionare le varie opzioni dei menu
◀▶	Permettono di spostare il cursore per modificare i dati inseriti
OK	Conferma della selezione visualizzata o inserimento dati
CANC	Cancellazione dei dati immessi
ESC	Annullamento della selezione e uscita dai menu di programmazione

Visualizzazioni da **display** del centralino:

- A** modalità AUDIO
V modalità VIDEO
- * modalità GIORNO
☾ modalità NOTTE
- ☑ indica la fonica attiva
- ☎ indica la funzione "FollowMe" attiva
- ora (ore: minuti:secondi)
- nome del giorno (Lun, Mar, ecc.) e data (giorno/mese/anno)
- ! si ha una configurazione tra i 2 centralini NON compatibile
? il centralino non ha ancora rilevato la presenza del centralino remoto
- P** indica il centralino configurato in parallelo
S indica il centralino configurato in serie
- ↕ **fissa** indica il corretto funzionamento della linea seriale
↕ **lampeggiate** indica il malfunzionamento della linea seriale
- LM lampeggiate** indica un corto circuito sulla linea montante, la scritta è accompagnata dalla ripetizione di un tono acustico. Il centralino rifiuta qualsiasi tentativo di chiamata o inoltra della stessa verso i posti interni, vengono invece gestite normalmente tutte le chiamate in arrivo dal posto esterno.
LP lampeggiate indica che il posto esterno non è collegato
- 📞=5 **lampeggiate** indica il numero di chiamate non risposte in modalità GIORNO e NOTTE
- 🚨=1 **lampeggiate** indica il numero di allarmi ricevuti e non evasi

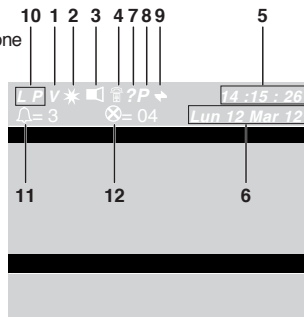

Tastiera alfanumerica

Per alcune funzioni la tastiera consente di digitare sia numeri che lettere, questo avviene premendo più volte lo stesso tasto, ad esempio premendo il tasto 2, sul display appariranno in successione a, b, c, A - B - C - 2;

- ① tasto per inserire i simboli .,:;?!()
- # tasto per inserire un trattino
- * tasto per inserire il simbolo +
- ⓪ tasto per inserire uno spazio tra i caratteri
- OK** Conferma i dati inseriti
- CANC** Cancella i dati inseriti

Descrizione generica

Le funzioni principali del centralino sono le seguenti:

- chiamare un posto interno
- ricevere chiamate dai posti esterni ed inoltrarle eventualmente ai posti interni
- ricevere chiamate ordinarie o di allarme dai posti interni
- comandare l'elettroserratura dei posti esterni
- attivare un relè

Il centralino di portineria prevede inoltre:

- una gestione GIORNO/NOTTE che consente di abilitare le funzioni del centralino solo in determinate fasce orarie programmabili dall'utente;
- una CODA CHIAMATE, nella quale vengono memorizzate le chiamate provenienti dai posti interni alle quali non è stato possibile rispondere;
- una RUBRICA la cui programmazione consente di identificare facilmente l'utente chiamante.

UTILIZZO

Le seguenti funzioni sono quelle che caratterizzano il centralino ed il suo modo di operare, sono tutte accessibili in modo diretto senza ricorrere ai menu.

U1 Come rispondere a una chiamata da posto interno

Quando il centralino riceve una chiamata da un posto interno:

- viene visualizzato il nome del posto interno da cui giunge la chiamata se inserito nella rubrica (vedi "U17 Come inserire un nome in rubrica" pag. 15) oppure l'indirizzo del chiamante (es. 002).

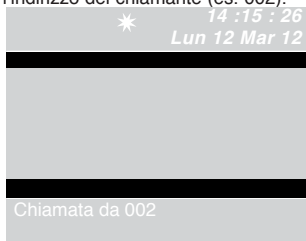

- per **rispondere** alla chiamata proveniente dal posto interno sollevare la cornetta entro 30 secondi;



- il centralino va in comunicazione con l'interno, la durata massima della conversazione è pari al tempo di fonica impostato sul centralino principale (**MENU/Impostazioni/Tempi/Fonica** - min. 10 secondi max. 90 secondi).

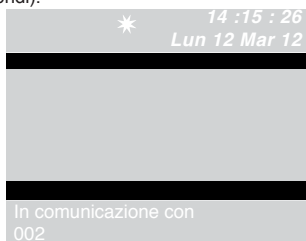

- per terminare la conversazione **riagganciare** la cornetta.



- per **rifiutare** la chiamata premere **CANC**.

ATTENZIONE!

Se il centralino è occupato o il centralinista è momentaneamente assente e non può rispondere entro 30 secondi, la chiamata verrà inserita nelle chiamate ricevute, vedi "U6 Come chiamare un posto interno presente nelle chiamate ricevute" pag. 9.

U2 Come rispondere a una chiamata da posto esterno

Il centralino **deve** essere in modalità GIORNO, in modalità NOTTE potrà rispondere alle sole chiamate dirette al centralino.

Il centralino può ricevere una chiamata da un posto esterno:

- indirizzata direttamente a un posto interno e in questo caso viene visualizzato il NOME del chiamato (se esiste in rubrica un nominativo associato al codice chiamato, vedi "U17 Come inserire un nome in rubrica" pag. 15) o l'indirizzo del chiamato stesso (es. 002).

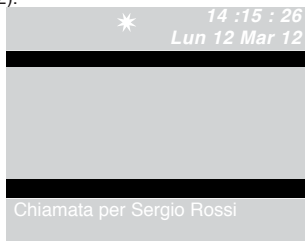

- oppure indirizzata direttamente al centralino (indirizzo=240)

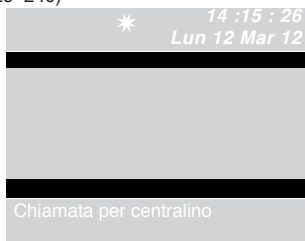

- per **rispondere** alla chiamata proveniente dal posto esterno sollevare la cornetta;



- il centralino va in comunicazione con l'esterno;

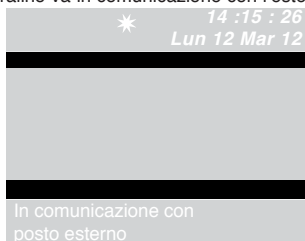

- premere eventualmente il tasto \leftrightarrow per attivare l'elettroserratura del posto esterno; se l'apriporta viene eseguito si udirà un tono di conferma;

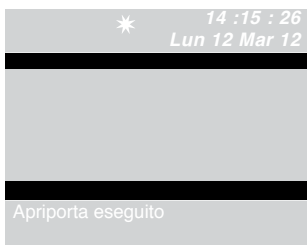

- per terminare la conversazione **riagganciare** la cornetta.

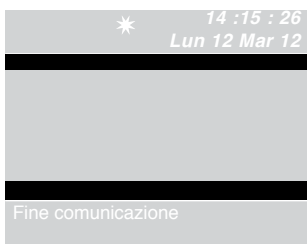

- per **rifiutare** la chiamata premere **CANC.**

ATTENZIONE!

In modalità **NOTTE** (vedi “19 - Impostazione modalità giornaliera” pag. 26) le chiamate da **posto esterno indirizzate a un posto interno vengono visualizzate sul display, ma non possono essere intercettate dal centralino.**





U3 Come chiamare un posto interno

Per chiamare un posto interno il centralino può utilizzare 3 modalità differenti:

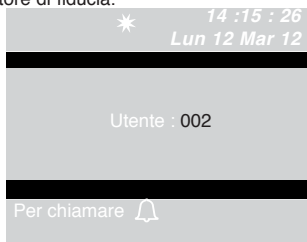
- digitare il numero di interno* e premere .

*Il numero da digitare dipende dalla configurazione del centralino vedi “C4 - Chiamata tramite codice Simplebus o indiretto” pag. 31; contattare il proprio installatore di fiducia.



- premere  e scorrere la rubrica con i tasti   fino a visualizzare il nominativo desiderato e premere .

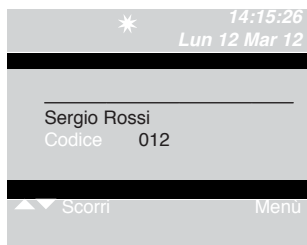

- premere il **numero breve** corrispondente (es. ) numero breve 1= codice memorizzato “002”, vedi “U22 Registrazione numeri brevi” pag. 18).

- se la chiamata è avvenuta correttamente:

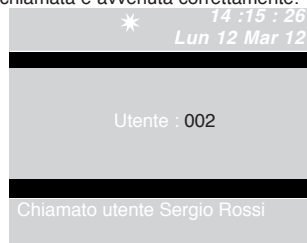

- se la chiamata non è avvenuta correttamente:

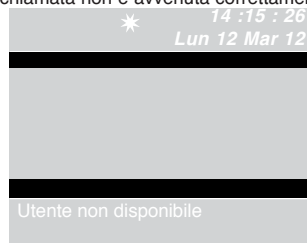

- se l'interno è occupato:

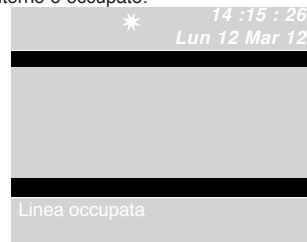

Quando l'**interno chiamato entra in fonica**, va in comunicazione con il centralino, la durata massima della conversazione è pari al tempo di fonica impostato sul centralino principale (**MENU/Impostazioni/Tempi/Fonica** - min. 10 secondi max. 90 secondi).

U4 Come inoltrare una chiamata da posto esterno a posto interno

Quando il centralino riceve una chiamata da un posto esterno indirizzata a un posto interno:

- viene visualizzato il NOME del chiamato (se esiste in rubrica un nominativo associato al codice chiamato, vedi "U17 Come inserire un nome in rubrica" pag. 15).

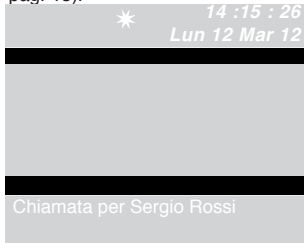

- per **rispondere** alla chiamata proveniente dal posto esterno sollevare la cornetta entro 60 secondi;



- il centralino va in comunicazione con l'esterno, la durata massima della conversazione è di 90 secondi;

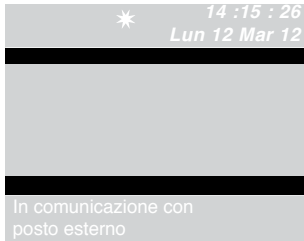

- premere il tasto  per mettere in attesa il posto esterno;

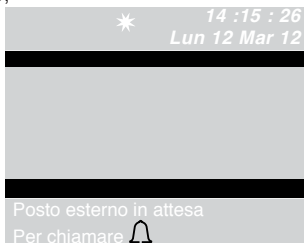

- Se l'interno **non accetta** l'inoltro della conversazione, il posto esterno rimane in attesa; chiudere la conversazione col posto interno e premere il tasto  per rimettersi in comunicazione col posto esterno;

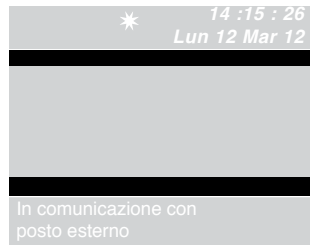

- per terminare la conversazione **riagganciare** la cornetta.



U5 Come mettere in comunicazione 2 interni tra loro (funzione intercomunicante)

Quando il centralino è in comunicazione con un posto interno (es. 002) che desidera parlare con un altro posto interno (es. 003):

- mettere in attesa l'interno con cui si è in linea (es. 002), premendo il tasto ;

- chiamare il posto interno desiderato (es. 003, vedi "U3 Come chiamare un posto interno" pag. 7);

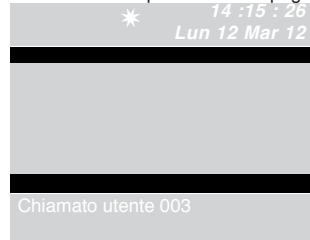

Quando l'interno **chiamato entra in fonica**, va in comunicazione con il centralino;

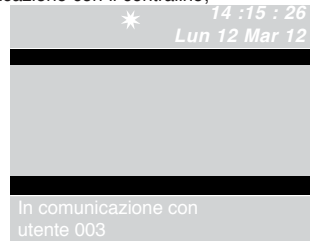

- Per inoltrare la conversazione verso l'altro posto interno premere il tasto ; il posto interno (003) entra in comunicazione col posto interno (002); la durata massima della comunicazione è di 2,5 minuti;

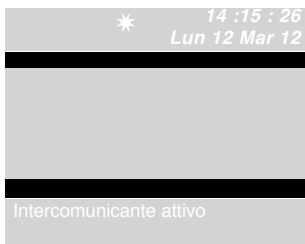



- **riagganciare** la cornetta.

Premere **CANC** per resettare una chiamata intercomunicante attiva da più di un minuto.

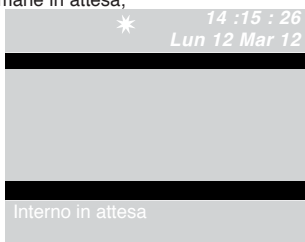

Se l'interno **non accetta** l'inoltro della conversazione o quando l'**impianto è occupato** o se la **chiamata non è avvenuta correttamente**, il posto interno (002) rimane in attesa;



- chiudere la comunicazione col posto interno (003) e premere il tasto  per rimettersi in comunicazione col posto interno (002);

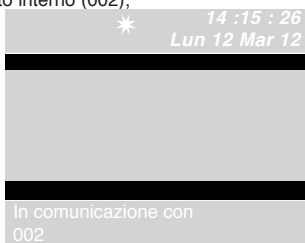

- per terminare la conversazione **riagganciare** la cornetta.



ATTENZIONE!

Se il posto esterno chiama il centralino durante una chiamata intercomunicante tra posti interni attiva da più di un minuto, questa viene automaticamente resettata per permettere al centralino di gestire la chiamata in arrivo.

U6 Come chiamare un posto interno presente nelle chiamate ricevute

Quando il centralino riceve una chiamata da posto interno che non viene gestita entro 30 sec. (operatore momentaneamente assente o occupato in altra conversazione), questa viene automaticamente memorizzata nel menu **Chiamate ricevute**.

Il centralino può memorizzare un numero massimo di 10 chiamate inevase. L'undicesima chiamata sostituisce la prima.

Sul display verrà indicato il numero delle chiamate ricevute (es. =3 lampeggiante).

Per chiamare i posti interni presenti nelle chiamate ricevute occorre:

- premere il tasto **MENU** e visualizzare tramite i tasti ▼▲ il menu **Chiamate ricevute**, premere il tasto **OK**;

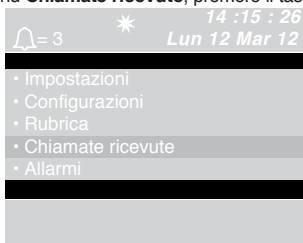

- visualizzare tramite i tasti ▼▲ la voce **Visualizza**, premere il tasto **OK**;

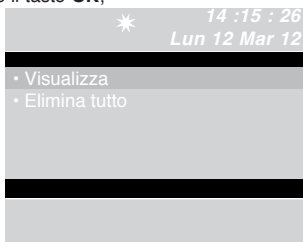

- verranno visualizzate in ordine cronologico le chiamate in entrata a partire dall'ultima ricevuta; utilizzare i tasti ▼▲ per scorrere la lista.

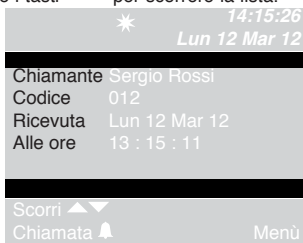

- premere il tasto  per chiamare il posto interno visualizzato.

- premendo il tasto **MENU** viene visualizzata una schermata nell'angolo in basso a destra.

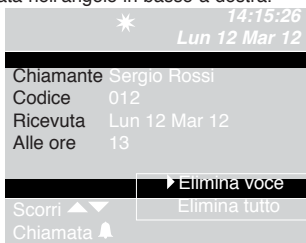





- premere il tasto **OK** per confermare le impostazioni;
- premere ripetutamente il tasto **ESC** per tornare alla schermata principale.

U7 Come chiamare un centralino secondario da centralino principale

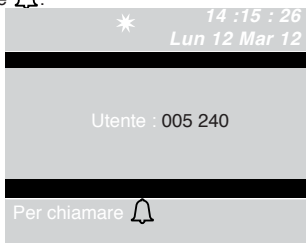
Per chiamare un centralino secondario, il centralino principale può utilizzare una delle 3 seguenti modalità:

1 digitare il numero del centralino (es. 005 240) e premere :



2 scorrere la rubrica  con i tasti   fino a visualizzare il nominativo e premere :

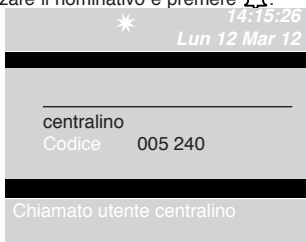

3 premere il numero breve corrispondente (vedi "U22- Registrazione numeri brevi" pag. 18).

- Se la chiamata è avvenuta correttamente:

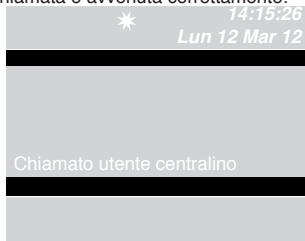

- se la chiamata non è avvenuta correttamente:

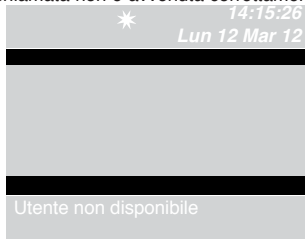

- se l'impianto è occupato:

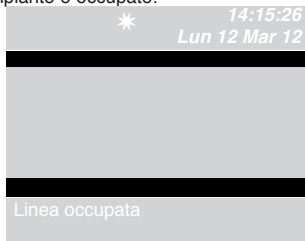

Quando il **centralino chiamato solleva la cornetta**, va in comunicazione con il centralino principale, la durata massima della conversazione è pari al tempo di fonica impostato sul centralino principale (**MENU/Impostazioni/Tempi/Fonica** - min. 10 secondi max. 90 secondi).

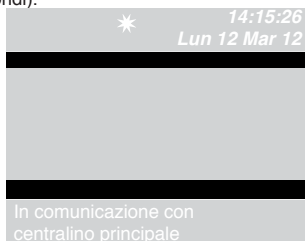

- per terminare la conversazione **riagganciare** la cornetta.



ATTENZIONE!

Il centralino secondario e il centralino principale in comunicazione tra di loro, non possono inoltre le chiamate o metterle in attesa.

U8 Come chiamare un centralino principale da centralino secondario

Per chiamare un centralino principale da centralino secondario premere (#).

Quando il **centralino principale chiamato solleva la cornetta**, va in comunicazione con il centralino secondario, la durata massima della conversazione è pari al tempo di fonica impostato sul centralino principale (**MENU/Impostazioni/Tempi/Fonica** - min. 10 secondi max. 90 secondi).

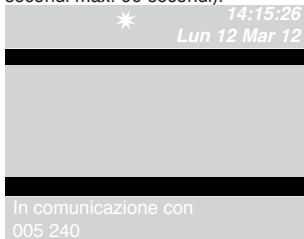

- per terminare la conversazione **riagganciare** la cornetta.



ATTENZIONE!

Il centralino secondario e il centralino principale in comunicazione tra di loro, non possono inoltrare le chiamate o metterle in attesa.

U9 Come rispondere a una chiamata da centralino secondario a centralino principale

Quando il centralino principale riceve una chiamata da centralino secondario:

- viene visualizzato il NOME del centralino secondario da cui giunge la chiamata (se inserito nella rubrica, vedi "U17 Come inserire un nome in rubrica" pag. 15) oppure l'indirizzo del centralino chiamante (es. 005 240).

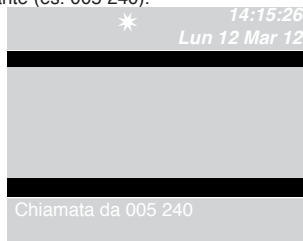

005= indica la "zona"
240= indica l'ID generico del centralino

- per **rifiutare** la chiamata premere **CANC**;
- per **rispondere** alla chiamata proveniente dal centralino secondario sollevare la cornetta;



- il centralino principale va in comunicazione con il centralino secondario, la durata massima della conversazione è pari al tempo di fonica impostato sul centralino principale (**MENU/Impostazioni/Tempi/Fonica** - min. 10 secondi max. 90 secondi);

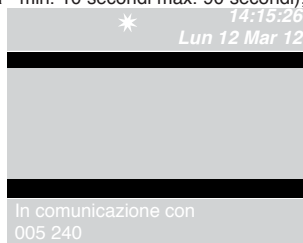

- per terminare la conversazione **riagganciare** la cornetta.



ATTENZIONE!

Se il centralino è occupato o il Centralinista è momentaneamente assente e non può rispondere entro 30 secondi, essa verrà inserita nella coda chiamate (vedi "U6 Come chiamare un posto interno presente nelle chiamate ricevute" pag. 9).

U10 Come rispondere a una chiamata da centralino principale a centralino secondario

Quando il centralino secondario riceve una chiamata dal centralino principale:

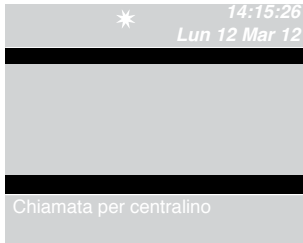

- per **rispondere** alla chiamata proveniente del centralino principale sollevare la cornetta;



- per terminare la conversazione **riagganciare** la cornetta.



ATTENZIONE!

Se il centralino è occupato o il Centralinista è momentaneamente assente e non può rispondere entro 30 secondi, essa verrà inserita nella coda chiamate (vedi "U6 Come chiamare un posto interno presente nelle chiamate ricevute" pag. 9).

U11 Come attivare o disattivare i centralini principali

Nel caso di 2 centralini principali in configurazione serie (vedi pag. 116), agire in uno dei seguenti modi:

1 - premere il tasto **MENU** del centralino attivo e visualizzare tramite i tasti $\blacktriangledown\blacktriangle$ il menu **Configurazioni**, premere il tasto **OK**;

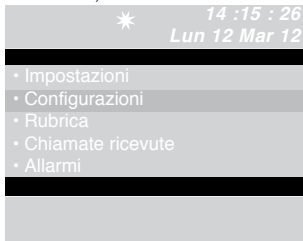

- visualizzare tramite i tasti $\blacktriangledown\blacktriangle$ il menu **Sistema**, premere il tasto **OK**;

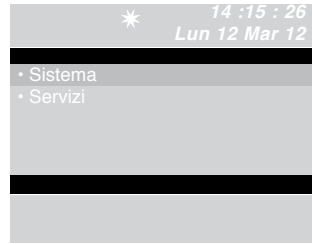

- visualizzare tramite i tasti $\blacktriangledown\blacktriangle$ il menu **Link**, premere il tasto **OK**;

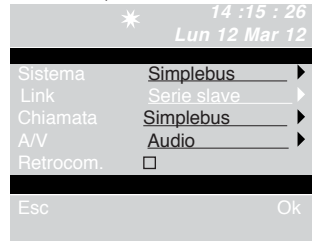

- selezionare **Serie slave** con i tasti $\blacktriangleleft\blacktriangleright$ per renderlo inattivo.

Il centralino si spegne mentre l'altro centralino si accende in automatico diventando **Serie master**.

- premere il tasto **OK** per confermare le impostazioni;
- premere ripetutamente il tasto **ESC** per tornare alla schermata principale.

o

1 - premere il tasto **MENU** del centralino inattivo e visualizzare tramite i tasti $\blacktriangledown\blacktriangle$ il menu **Configurazioni**, premere il tasto **OK**;

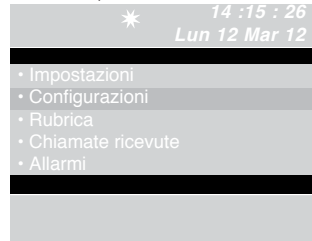

- visualizzare tramite i tasti $\blacktriangledown\blacktriangle$ il menu **Sistema**, premere il tasto **OK**;

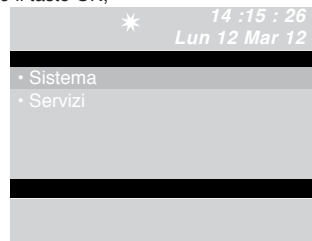

- visualizzare tramite i tasti ▼▲ il menu **Link**, premere il tasto **OK**;

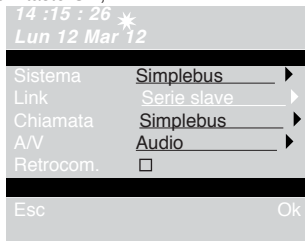

- selezionare **Serie master** con i tasti ◀▶ per confermare che il centralino deve essere attivo. L'altro centralino si disattiva in automatico diventando **Serie slave**.

- premere il tasto **OK** per confermare le impostazioni;
- premere ripetutamente il tasto **ESC** per tornare alla schermata principale.

U12 Come utilizzare l'apriporta

È possibile comandare l'elettroserratura del posto esterno premendo il tasto ⇄; se il comando viene eseguito si udirà un tono di conferma.

U13 Come attivare la funzione "Seguimi" (FollowMe)

Tramite questa funzione è possibile deviare le chiamate destinate al centralino verso apparecchi telefonici locali o remoti.

ATTENZIONE!

Per l'utilizzo di questa funzione deve essere presente la centrale Art. 2906 con interfaccia Art. 2912. Rivolgersi al proprio installatore di fiducia. Questa funzione è attivabile solo sul centralino impostato come secondario (vedi "C1 Tipo di centralino" pag. 29).

Per attivare questa funzione:

- premere il tasto **MENU** e visualizzare tramite i tasti ▼▲ il menu **Configurazioni**, premere il tasto **OK**;

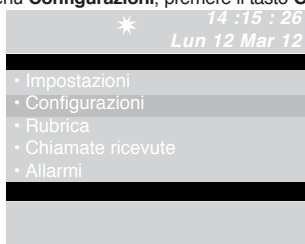

- visualizzare tramite i tasti ▼▲ il menu **Servizi**, premere il tasto **OK**;

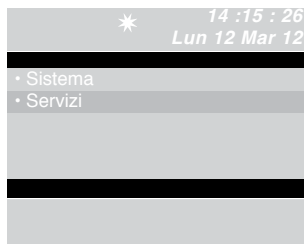

- visualizzare tramite i tasti ▼▲ il servizio **FollowMe**.
Attivare il servizio con il tasto ▶.
Disabilitare con ◀.

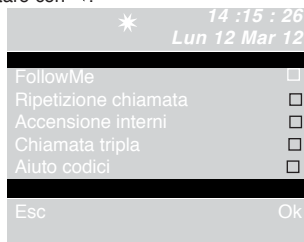

- premere il tasto **OK** per confermare le impostazioni;
- premere ripetutamente il tasto **ESC** per tornare alla schermata principale.

A seguito di una chiamata, il centralino suonerà comunque e finchè l'apparecchio remoto non entra in comunicazione, è possibile rispondere alla chiamata dal centralino annullando la funzione "Seguimi".

U14 Come attivare un relè supplementare (es. per attivare in modo indipendente e con un comando dedicato: luci, contatti di allarme TVCC, cancelli carrai, ingressi senza posto esterno o altri dispositivi)

Gli attuatori si possono attivare sia in modalità di riposo, sia in modalità di conversazione verso il posto esterno.

ATTENZIONE!

Per l'utilizzo di questa funzione deve essere presente un posto esterno principale e degli attuatori Art. 1256. Rivolgersi al proprio installatore di fiducia.

Per attivare l'attuatore:

- premere il tasto (*), verrà richiesto l'inserimento del codice per attivare un attuatore specifico, in caso di codice mancante verrà attivato un attuatore generico;

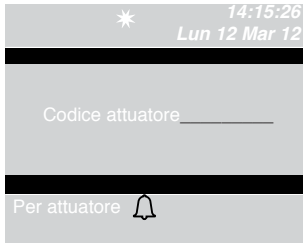

- per confermare l'attivazione dell'attuatore premere il tasto .

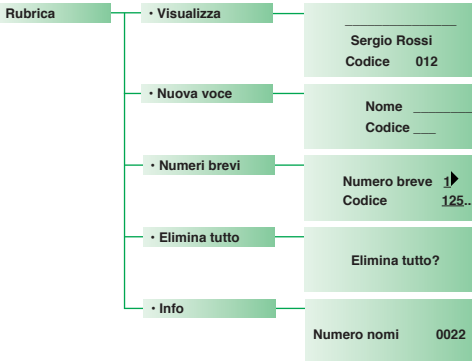

U15 Come utilizzare la rubrica

Possano essere inseriti al massimo 4000 nomi che abbiano al massimo 13 caratteri alfanumerici, ad ogni nominativo deve essere associato un codice che corrisponde a quello dell'interno desiderato.

U16 Come cercare un nome in rubrica

Per visualizzare la rubrica premere il tasto e scorrere la lista degli utenti con i tasti ; per aumentare la velocità di scorrimento tener premuto il tasto. Verranno visualizzati in serie il NOME e il CODICE associati ad ogni utente.

Oppure

- premere il tasto **MENU** e visualizzare tramite i tasti il menu **Rubrica**, premere il tasto **OK**;

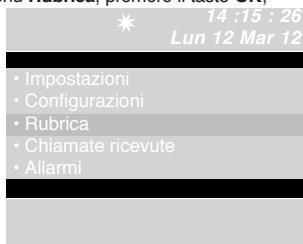

- visualizzare tramite i tasti la voce **Visualizza**, premere il tasto **OK**;

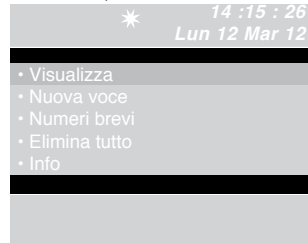

- verranno visualizzati in ordine alfabetico i nominativi memorizzati in rubrica; utilizzare i tasti per scorrere la lista.

Per velocizzare lo scorrimento dei nominativi, tener premuto il tasto o .



Oppure

- inserire il nome anche con parte dell'estensione; Se sono presenti più utenti con l'iniziale inserita, è possibile scorrere la lista coi tasti .

- premendo il tasto **MENU** viene visualizzata una schermata nell'angolo in basso a destra.

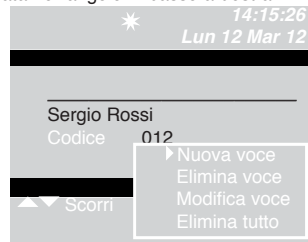

È possibile inserire una nuova voce, eliminare la voce selezionata, modificarla o cancellare l'intera rubrica. Selezionare l'operazione desiderata coi tasti , premere il tasto **OK**.

- premere ripetutamente il tasto **ESC** per tornare alla schermata principale.

U17 Come inserire un nome in rubrica

Se si vuole inserire un nome in rubrica:

- premere il tasto **MENU** e visualizzare tramite i tasti ▼ ▲ il menu **Rubrica**, premere il tasto **OK**;

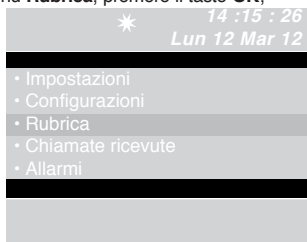

- visualizzare tramite i tasti ▼ ▲ la voce **Nuova voce**, premere il tasto **OK**;

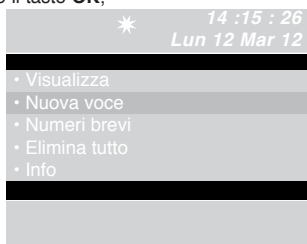

- inserire il nuovo nominativo utilizzando la tastiera alfanumerica; premere il tasto ▼ e inserire il codice mediante la tastiera.

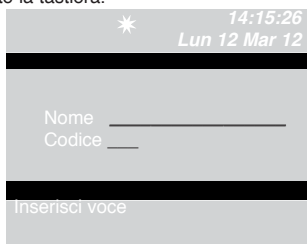

- premere il tasto **OK** per confermare le impostazioni;



- premendo il tasto **MENU** viene visualizzata una schermata nell'angolo in basso a destra.

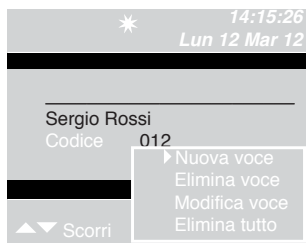

È possibile inserire una nuova voce, eliminare la voce selezionata, modificarla o cancellare l'intera rubrica. Selezionare l'operazione desiderata coi tasti ▼ ▲, premere il tasto **OK**.

- premere ripetutamente il tasto **ESC** per tornare alla schermata principale.

U18 Come cancellare un nome in rubrica

ATTENZIONE!

Per la cancellazione dell'intera rubrica vedi "U20 - Cancellazione rubrica" pag. 17.

Se si vuole cancellare un nome in rubrica:

- premere il tasto **MENU** e visualizzare tramite i tasti ▼ ▲ il menu **Rubrica**, premere il tasto **OK**;

- visualizzare tramite i tasti ▼ ▲ la voce **Visualizza**, premere il tasto **OK**;

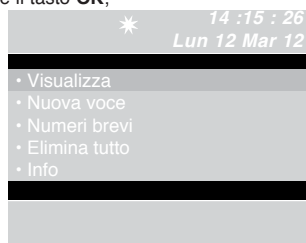

- verranno visualizzati in ordine alfabetico i nominativi memorizzati in rubrica; utilizzare i tasti ▼ ▲ per scorrere la lista.

Per velocizzare lo scorrimento dei nominativi, tener premuto il tasto ▼ o ▲.



Oppure

- inserire il nome anche con parte dell'estensione;
Se sono presenti più utenti con l'iniziale inserita, è possibile scorrere la lista coi tasti ▼▲.



- premendo il tasto **MENU** viene visualizzata una schermata nell'angolo in basso a destra.

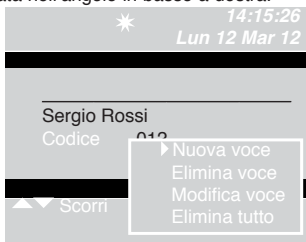

- visualizzare tramite il tasto ▼ la voce **Elimina voce**, premere il tasto **OK**;

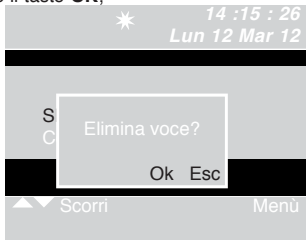

- per confermare l'eliminazione premere il tasto **OK**;
- premere ripetutamente il tasto **ESC** per tornare alla schermata principale.

U19 Come modificare un nome in rubrica

Se si vuole modificare un nome in rubrica:

- premere il tasto **MENU** e visualizzare tramite i tasti ▼▲ il menu **Rubrica**, premere il tasto **OK**

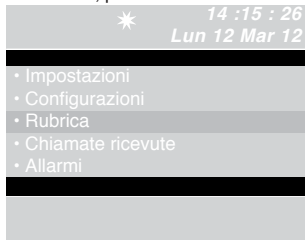

- visualizzare tramite i tasti ▼▲ la voce **Visualizza**, premere il tasto **OK**;

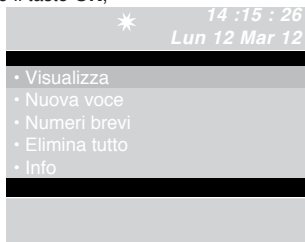

- verranno visualizzati in ordine alfabetico i nominativi memorizzati in rubrica; utilizzare i tasti ▼▲ per scorrere la lista.

Per velocizzare lo scorrimento dei nominativi, tener premuto il tasto ▼ o ▲.

Oppure

- inserire il nome anche con parte dell'estensione;
Se sono presenti più utenti con l'iniziale inserita, è possibile scorrere la lista coi tasti ▼▲.

- premendo il tasto **MENU** viene visualizzata una schermata nell'angolo in basso a destra.

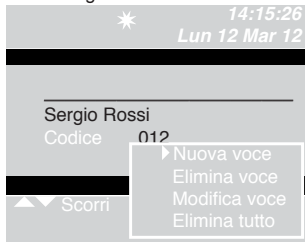

- visualizzare tramite il tasto ▼ la voce **Modifica voce**, premere il tasto **OK**;

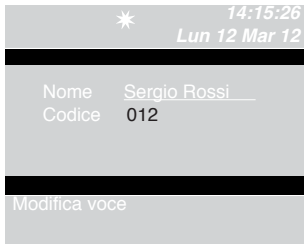

- visualizzare tramite i tasti ▼▲ la voce da modificare (nome o codice).

- premere **CANC** per cancellare la voce selezionata e inserire il nuovo nome o codice tramite la tastiera alfanumerica ;

- per confermare la modifica del nome premere il tasto **OK**; premere **ESC** per uscire.

U20 Cancellazione rubrica

- premere il tasto **MENU** e visualizzare tramite i tasti ▼▲ il menu **Rubrica**, premere il tasto **OK**;

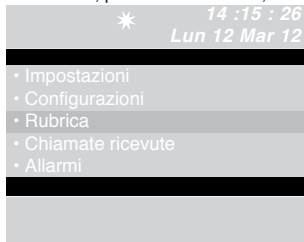

- visualizzare tramite i tasti ▼▲ la voce **Elimina tutto**, premere il tasto **OK**;

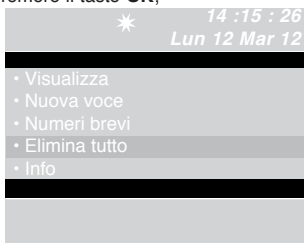

- comparirà una schermata in cui verrà chiesto se si vuole eliminare l'intera rubrica; confermare con il tasto **OK** oppure annullare con il tasto **ESC**;

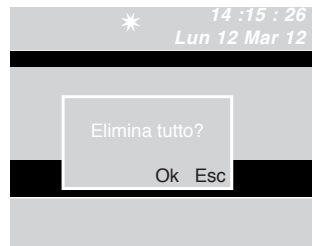

- premere ripetutamente il tasto **ESC** per tornare alla schermata principale.

U21 Info rubrica

- premere il tasto **MENU** e visualizzare tramite i tasti ▼▲ il menu **Rubrica**, premere il tasto **OK**;

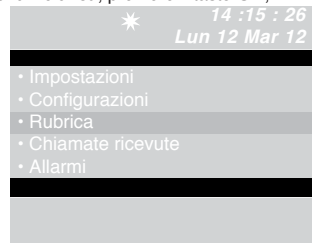

- visualizzare tramite i tasti ▼▲ la voce **Info**, premere il tasto **OK**;

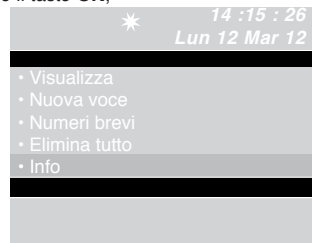

- comparirà una schermata in cui verrà indicato il numero dei nominativi memorizzati in rubrica;

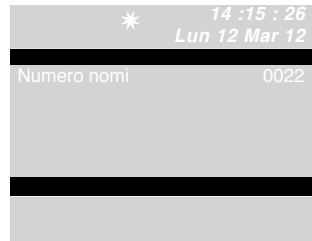

- premere ripetutamente il tasto **ESC** per tornare alla schermata principale.

U22 Registrazione numeri brevi

Tramite questa funzione è possibile memorizzare modificare e cancellare i numeri brevi.

- premere il tasto **MENU** e visualizzare tramite i tasti ▼ ▲ il menu **Rubrica**, premere il tasto **OK**;

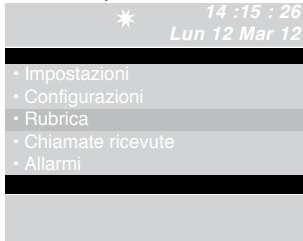

- visualizzare tramite i tasti ▼ ▲ la voce **Numeri brevi**, premere il tasto **OK**;

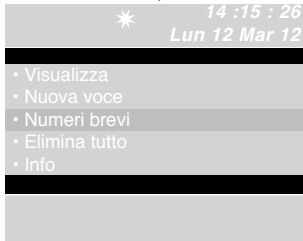

- visualizzare tramite i tasti ◀ ▶ il numero breve (da 1 a 8) a cui abbinare un codice;

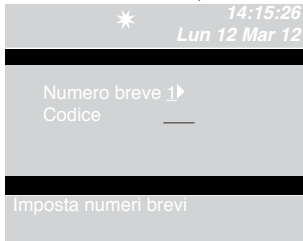

- premere il tasto ▼ e inserire il codice mediante la tastiera;

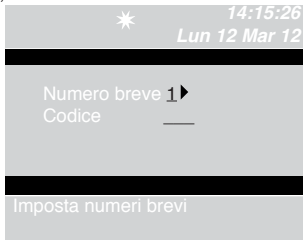

- premere il tasto **OK** per confermare le impostazioni;
- premere ripetutamente il tasto **ESC** per tornare alla schermata principale.

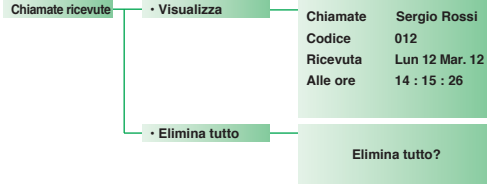

U23 - Visualizzazione chiamate ricevute

- Per accedere velocemente alla visualizzazione delle chiamate ricevute premere il tasto **MENU + tasto 2** oppure premere il tasto **MENU** e visualizzare tramite i tasti ▼ ▲ il menu **Chiamate ricevute**, premere il tasto **OK**;

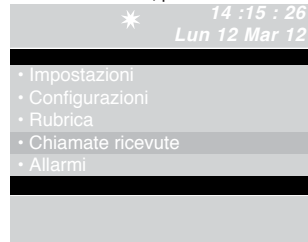

- visualizzare tramite i tasti ▼ ▲ la voce **Visualizza**, premere il tasto **OK**;

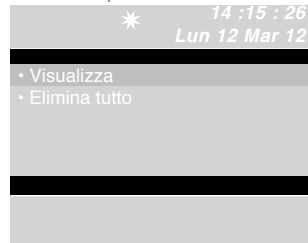

- verranno visualizzate in ordine cronologico le chiamate in entrata a partire dall'ultima ricevuta; utilizzare i tasti ▼ ▲ per scorrere la lista. Per velocizzare lo scorrimento dei nominativi, tener premuto il tasto ▼ o ▲.



- premendo il tasto **MENU** viene visualizzata una schermata nell'angolo in basso a destra.

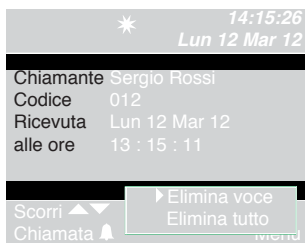

- premere il tasto **OK** per confermare le impostazioni;
- premere ripetutamente il tasto **ESC** per tornare alla schermata principale.

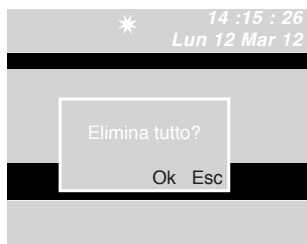

- premere ripetutamente il tasto **ESC** per tornare alla schermata principale.

U24 - Cancellazione lista chiamate ricevute-

- premere il tasto **MENU** e visualizzare tramite i tasti ▼ ▲ il menu **Chiamate ricevute**, premere il tasto **OK**;

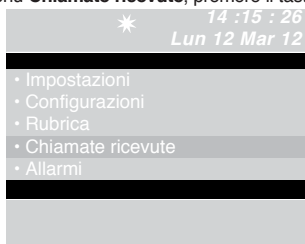

- visualizzare tramite i tasti ▼ ▲ la voce **Elimina tutto**, premere il tasto **OK**;

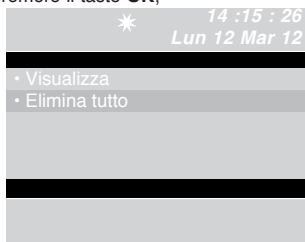

- comparirà una schermata in cui verrà chiesto se si vuole eliminare la lista delle chiamate entranti; confermare con il tasto **OK** oppure annullare con il tasto **ESC**;

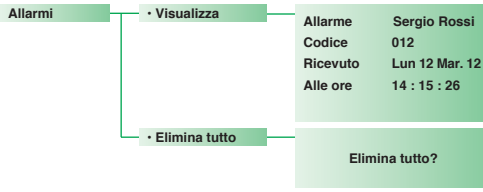

U25 - Visualizzazione allarmi

- Per accedere velocemente alla visualizzazione degli allarmi premere il tasto **MENU + tasto 1** oppure premere il tasto **MENU** e visualizzare tramite i tasti **▼▲** il menu **Allarmi**, premere il tasto **OK**;

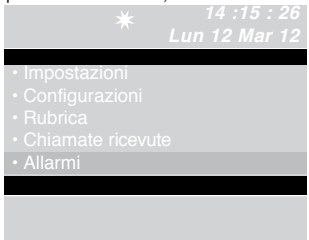

- visualizzare tramite i tasti **▼▲** la voce **Visualizza**, premere il tasto **OK**;

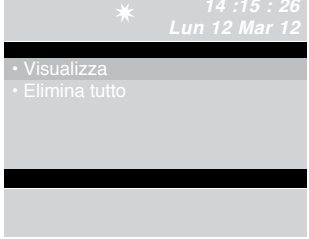

- verranno visualizzati in ordine cronologico a partire dall'ultimo ricevuto; utilizzare i tasti **▼▲** per scorrere la lista.

Per velocizzare lo scorrimento dei nominativi, tener premuto il tasto **▼** o **▲**.

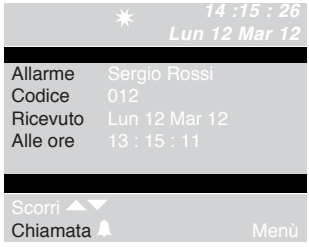

- premendo il tasto **MENU** viene visualizzata una schermata nell'angolo in basso a destra.

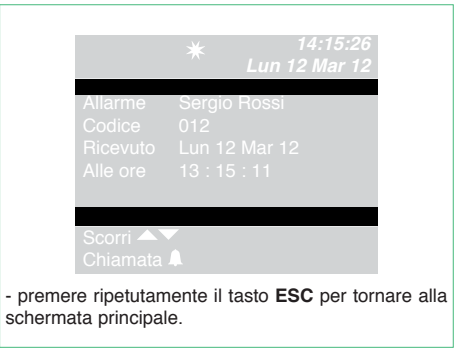

- premere ripetutamente il tasto **ESC** per tornare alla schermata principale.

U26 - Cancellazione lista allarmi ricevuti

- premere il tasto **MENU** e visualizzare tramite i tasti **▼▲** il menu **Allarmi**, premere il tasto **OK**;

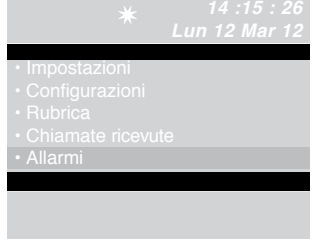

- visualizzare tramite i tasti **▼▲** la voce **Elimina tutto**, premere il tasto **OK**;

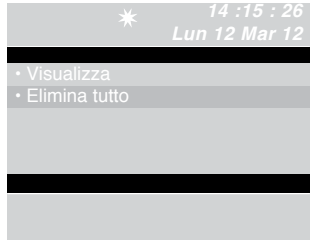

- comparirà una schermata in cui verrà chiesto se si vuole eliminare la lista degli allarmi entranti; confermare con il tasto **OK** oppure annullare con il tasto **ESC**;

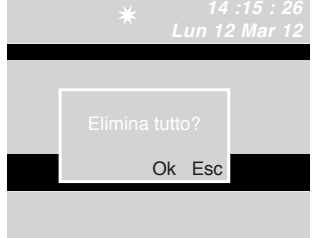

- premere ripetutamente il tasto **ESC** per tornare alla schermata principale.

IMPOSTAZIONI

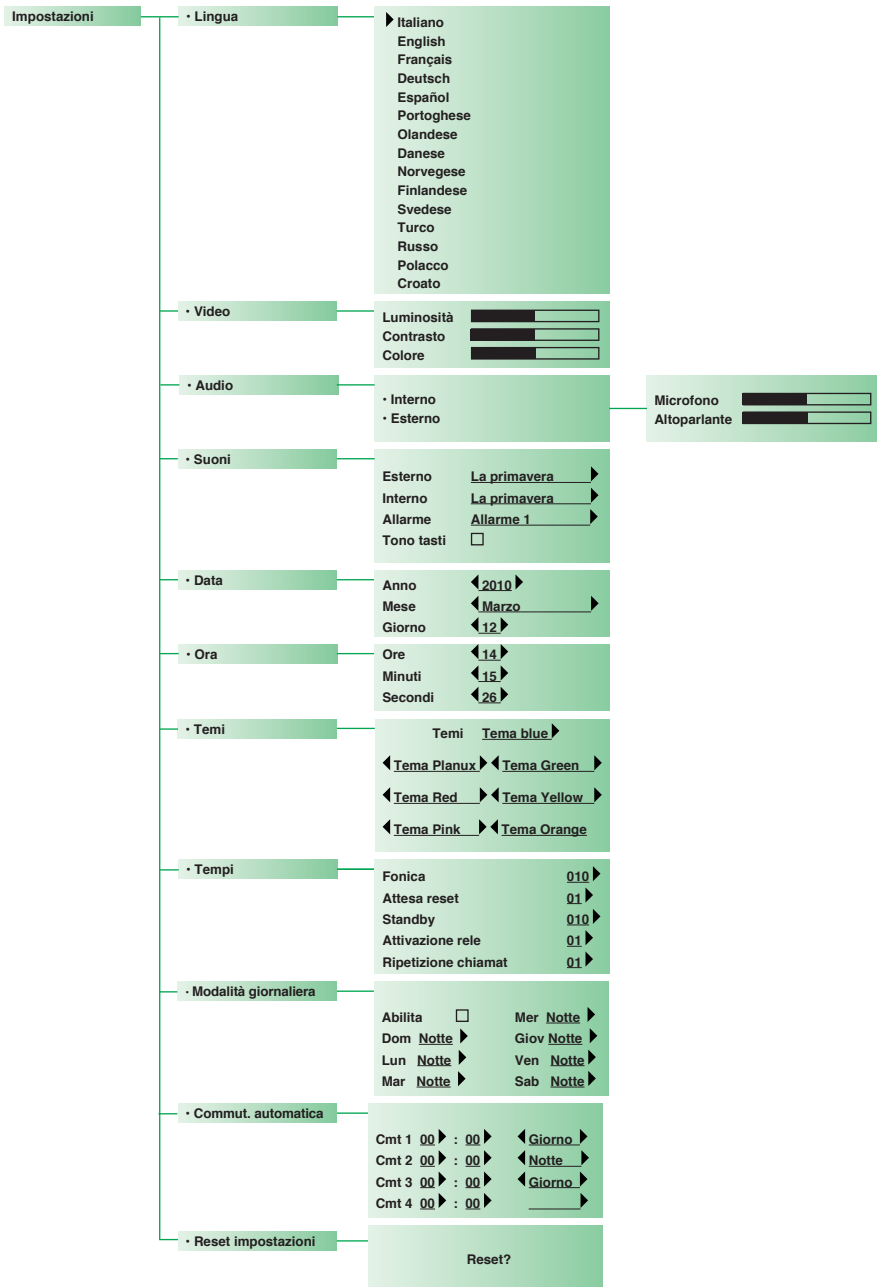

Microfono

Altoparlante

I1 - Modifica lingua

È possibile impostare la lingua selezionandola tra le seguenti:

► Italiano (default)

English
 Français
 Deutsch
 Español
 Portoghese
 Olandese
 Danese
 Norvegese
 Finlandese
 Svedese
 Turco
 Russo
 Polacco
 Croato

- premere il tasto **MENU** e visualizzare tramite i tasti ▼▲ il menu **Impostazioni**, premere il tasto **OK**;

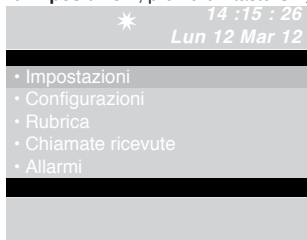

- visualizzare tramite i tasti ▼▲ il menu **Lingua**, premere il tasto **OK**;



- visualizzare tramite i tasti ▼▲ la lingua scelta e premere il tasto **OK** per confermare;
- premere ripetutamente il tasto **ESC** per tornare alla schermata principale.

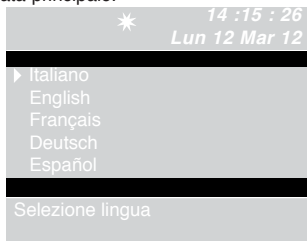

I2 - Impostazioni video

Tramite questa funzione è possibile regolare la luminosità, il contrasto e il colore del monitor del centralino.

- Per accedere velocemente alle impostazioni video premere il tasto **MENU + tasto 3** oppure premere il tasto **MENU** e visualizzare tramite i tasti ▼▲ il menu **Impostazioni**, premere il tasto **OK**;

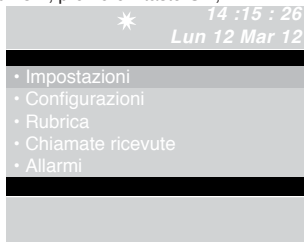

- visualizzare tramite i tasti ▼▲ il menu **Video**, premere il tasto **OK**;



- visualizzare tramite i tasti ▼▲ l'impostazione video da regolare (luminosità, contrasto, colore) e diminuire o aumentare il valore con i tasti ◀▶;



- premere il tasto **OK** per confermare le impostazioni;
- premere ripetutamente il tasto **ESC** per tornare alla schermata principale.

I3 - Impostazioni audio

Tramite questa funzione è possibile regolare il volume del microfono e dell'altoparlante del centralino verso i posti interni e verso il posto esterno.

N.B. Per modificare i volumi il centralino deve essere in comunicazione con il posto interno o il posto esterno.

- Per accedere velocemente alle impostazioni audio premere il tasto **MENU** + tasto **4 (esterno)** tasto **5 (interno)** oppure premere il tasto **MENU** e visualizzare tramite i tasti **▼▲** il menu **Impostazioni**, premere il tasto **OK**;

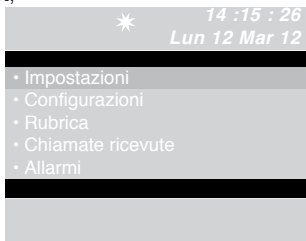

- visualizzare tramite i tasti **▼▲** il menu **Audio**, premere il tasto **OK**;



- visualizzare tramite i tasti **▼▲** l'impostazione audio da regolare (interno e/o esterno), premere il tasto **OK**;

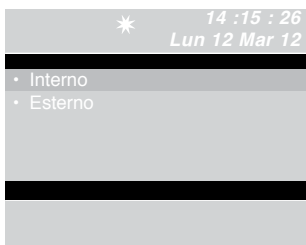

- visualizzare tramite i tasti **▼▲** l'impostazione audio da regolare (microfono e/o altoparlante) e diminuire o aumentare il valore con i tasti **◀▶**;

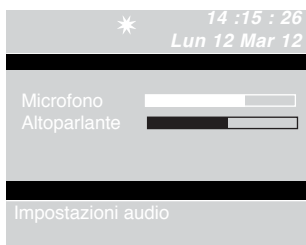

- premere il tasto **OK** per confermare le impostazioni;
- premere ripetutamente il tasto **ESC** per tornare alla schermata principale.

I4 - Impostazioni suoni

Tramite questa funzione è possibile impostare la melodia delle chiamate in ingresso dai posti interni, dal posto esterno e delle chiamate di allarme; è inoltre possibile attivare o disattivare il tono tasti.

- premere il tasto **MENU** e visualizzare tramite i tasti **▼▲** il menu **Impostazioni**, premere il tasto **OK**;

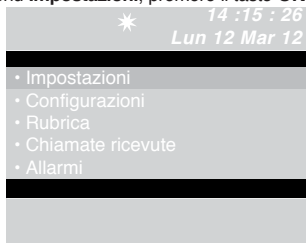

- visualizzare tramite i tasti **▼▲** il menu **Suoni**, premere il tasto **OK**;



- visualizzare tramite i tasti **▼▲** l'impostazione suono da regolare (esterno, interno, allarme o tono tasti);

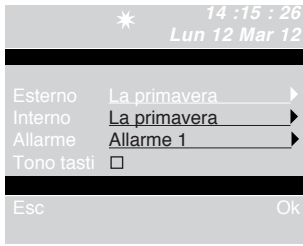

- selezionare la melodia con i tasti ◀▶.
- Attivare il servizio Tono tasti con il tasto ▶.
- Disabilitare con ◀;
- premere il tasto **OK** per confermare le impostazioni;
- premere ripetutamente il tasto **ESC** per tornare alla schermata principale.

15 - Modifica data

- premere il tasto **MENU** e visualizzare tramite i tasti ▼▲ il menu **Impostazioni**, premere il tasto **OK**;

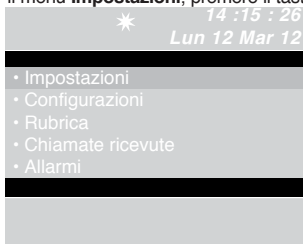

- visualizzare tramite i tasti ▼▲ il menu **Data**, premere il tasto **OK**;



- visualizzare tramite i tasti ▼▲ l'impostazione da regolare (anno, mese, giorno) e modificare con i tasti ◀▶;



- premere il tasto **OK** per confermare le impostazioni;
- premere ripetutamente il tasto **ESC** per tornare alla schermata principale.

16 - Modifica ora

- premere il tasto **MENU** e visualizzare tramite i tasti ▼▲ il menu **Impostazioni**, premere il tasto **OK**;

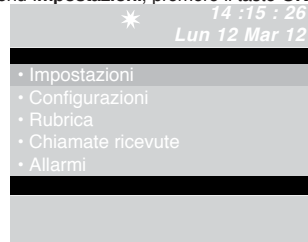

- visualizzare tramite i tasti ▼▲ il menu **Ora**, premere il tasto **OK**;



- visualizzare tramite i tasti ▼▲ l'impostazione da regolare (ore, minuti, secondi) e diminuire o aumentare il valore con i tasti ◀▶;

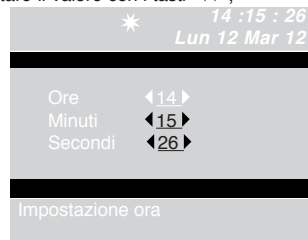

- premere il tasto **OK** per confermare le impostazioni;
- premere ripetutamente il tasto **ESC** per tornare alla schermata principale.

17 - Impostazione tema

Tramite questa funzione è possibile modificare i colori delle schermate dei menu.

- premere il tasto **MENU** e visualizzare tramite i tasti ▼ ▲ il menu **Impostazioni**, premere il tasto **OK**;

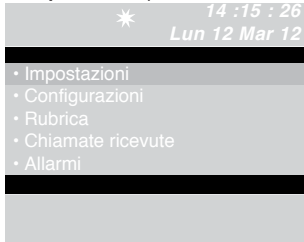

- visualizzare tramite i tasti ▼ ▲ il menu **Tem**i, premere il tasto **OK**;

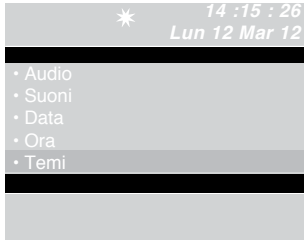

- selezionare il tema desiderato tramite i tasti ◀ ▶;

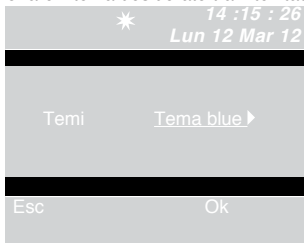

- premere il tasto **OK** per confermare l'impostazione;
- premere ripetutamente il tasto **ESC** per tornare alla schermata principale.

18 - Regolazione tempi

Tramite questa funzione è possibile impostare i tempi di fonica, attesa reset, standby, attivazione relè e di ripetizione di chiamata.

- premere il tasto **MENU** e visualizzare tramite i tasti ▼ ▲ il menu **Impostazioni**, premere il tasto **OK**;

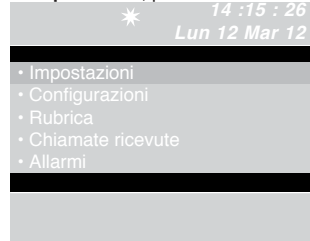

- visualizzare tramite i tasti ▼ ▲ il menu **Tem**pi, premere il tasto **OK**;



- visualizzare tramite i tasti ▼ ▲ l'impostazione da regolare (fonica, attesa reset, standby, attivazione relè, ripetizione di chiamata) e diminuire o aumentare il valore con i tasti ◀ ▶.

Per velocizzare lo scorrimento dei valori, tener premuto il tasto ◀ o ▶.

Valori di fonica: 10"-180" max

Valori di attesa reset: 1"-10" max

Valori di standby: 10"-120" max

Valori di attivazione relè: 1"- 20" max

Valori di ripetizione di chiamata: 1"- 30" max

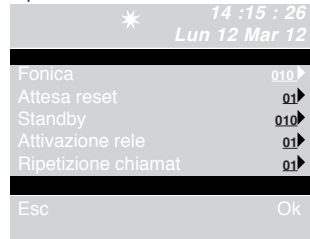



- premere il tasto **OK** per confermare le impostazioni;
- premere ripetutamente il tasto **ESC** per tornare alla schermata principale.

19 - Impostazione modalità giornaliera

Si può decidere di organizzare la settimana scegliendo per ogni giorno una delle seguenti 3 modalità di funzionamento:

- **AUTO**: il sistema passa dalla modalità GIORNO alla modalità NOTTE negli orari programmati.
- **NOTTE**: il sistema è in questa modalità per tutta la giornata.
- **GIORNO**: il sistema è in questa modalità per tutta la giornata.



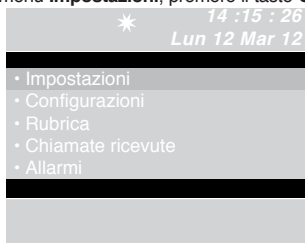

Nel caso in cui venga scelta l'impostazione "auto", la modalità di funzionamento all'interno della giornata commuterà a orari prestabiliti, in base alla programmazione impostata secondo il paragrafo "110 - Impostazione commut. automatica" a pag. 26. Per disattivare la funzione premere il tasto . Per attivarla:

- premere il tasto **MENU** e visualizzare tramite i tasti   il menu **Impostazioni**, premere il tasto **OK**;

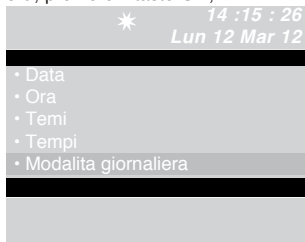



- visualizzare tramite i tasti   il menu **Modalità giornaliera**, premere il tasto **OK**;

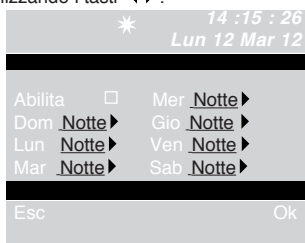

- visualizzare tramite i tasti   il giorno da impostare e selezionare la modalità notte, giorno o auto utilizzando i tasti  .



- finita la programmazione per ogni giorno della settimana, posizionarsi sulla voce **Abilita** e attivare l'intera

- programmazione con il tasto , per disabilitare ;
- premere il tasto **OK** per confermare le impostazioni;
- premere ripetutamente il tasto **ESC** per tornare alla schermata principale.



110 - Impostazione commut. automatica

È possibile impostare il sistema per consentire il passaggio automatico dalla modalità GIORNO alla modalità NOTTE in determinati orari programmabili dall'utente. Gli ORARI impostabili possono essere al MAX 4, e di ognuno andrà impostato la modalità di commutazione (Giorno o Notte).



Esempio:

- Si vuole impostare il Centalino con questi parametri:
07:00 -12:00 Funzionamento Giorno
13:00 - 22:00 Funzionamento Giorno

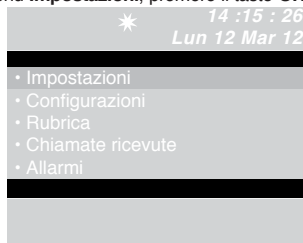

- premere il tasto **MENU** e visualizzare tramite i tasti   il menu **Impostazioni**, premere il tasto **OK**;



- visualizzare tramite i tasti   il menu **Commut. automatica**, premere il tasto **OK**;

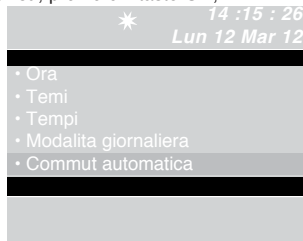

- il cursore si posizionerà in automatico sull'ora min. della commut. 1; diminuire o aumentare il valore con

i tasti ◀▶.

Il valore va da 00 a 23.

Per velocizzare lo scorrimento dei valori, tener premuto il tasto ◀ o ▶.

- posizionarsi sul valore in minuti della commut. 1 col tasto ▼, diminuire o aumentare il valore con i tasti ◀▶.

Il valore va da 00 a 59.

Per velocizzare lo scorrimento dei valori, tener premuto il tasto ◀ o ▶.

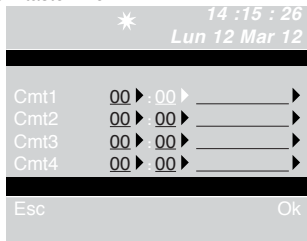

- posizionarsi sull'ultima voce della commut. 1 col tasto ▼, selezionare la modalità (giorno, notte) con i tasti ◀▶.

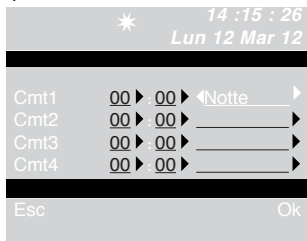

- seguire la procedura fin qui descritta per tutte le commutazioni necessarie;

- premere il tasto **OK** per confermare le impostazioni;

- premere ripetutamente il tasto **ESC** per tornare alla schermata principale.

I11 - Reset impostazioni

- premere il tasto **MENU** e visualizzare tramite i tasti ▼▲ il menu **Impostazioni**, premere il tasto **OK**;

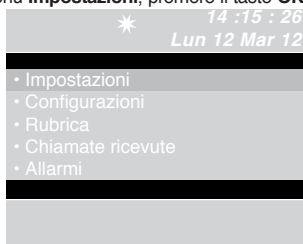

- visualizzare tramite i tasti ▼▲ il menu **Reset impostazioni**, premere il tasto **OK**;

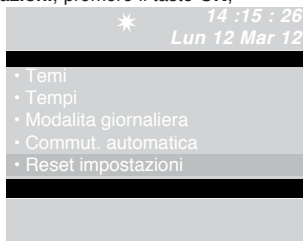

- comparirà una schermata in cui verrà chiesto se si vuole resettare le impostazioni; confermare con il tasto **OK** oppure annullare con il tasto **ESC**;

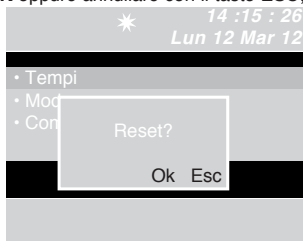

- se si preme **OK**, seguirà la schermata di riavvio del sistema;

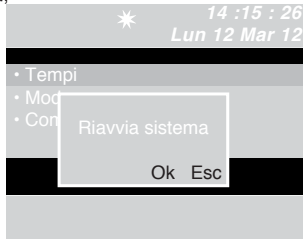

- confermare il riavvio del sistema con il tasto **OK** oppure annullare con il tasto **ESC**;

- premere ripetutamente il tasto **ESC** per tornare alla schermata principale.

CONFIGURAZIONI INSTALLATORE

IT

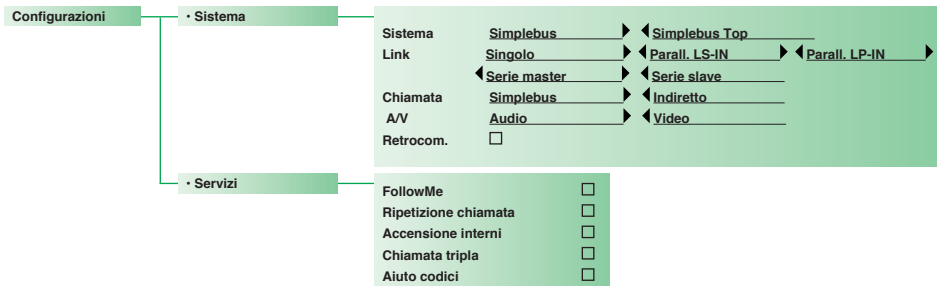

CONFIGURAZIONI INSTALLATORE

Questo capitolo è indirizzato al personale qualificato che, dopo l'installazione, procederà alla programmazione del centralino di portineria, tramite menu guidati e visualizzati sul display raggiungibili dal menu principale.

C1 - Tipo di centralino (modalità Simplebus Top)

Il centralino può essere secondario o principale.

- Impostare **Simplebus** quando il centralino è utilizzato come secondario, in uscita dai morsetti LM-LM degli scambi Art. 1424 (impianto Simplebus TOP) (vedi schema SBTOP/001DSMC pag. 110); oppure quando il centralino è utilizzato in impianti Simplebus con scambi Art. 1224A o in un impianto con singolo montante e in assenza di scambi.

ATTENZIONE! il centralino secondario non può essere configurato come centralino in parallelo.

- Impostare **Simplebus top** quando il centralino è utilizzato come principale in impianto Simplebus top, quindi posizionato nella tratta prima degli scambi Art. 1424 che definiscono le zone/montanti (vedi schema SBTOP/002DSMC pag. 112).

Il centralino secondario o principale deve essere poi configurato come:

- 1- SINGOLO
- 2- PARALLELO
- 3- SERIE.

- 1- Selezionare **singolo** quando il centralino è l'unico presente sull'impianto oppure l'unico che serve un determinato montante.

- 2- In presenza di 2 centralini principali o secondari che servono il medesimo montante, la configurazione **parallelo**, implica che entrambi i centralini saranno operativi con le stesse funzionalità (vedi schema SBTOP/005DSMC pag. 118).

Il primo dei due che risponde a una chiamata precluderà all'altro la possibilità di effettuare la stessa operazione.

L'accensione o lo spegnimento di uno dei 2 provocherà automaticamente l'accensione o lo spegnimento dell'altro.

Impostare come **Parall. LS-IN** il centralino collegato sotto la linea LS-LS dello scambio Art. 1424; impostare come **Parall. LP-IN** quello posto sotto la linea LPin-LPin dello scambio Art. 1424.

Per il centralino parallelo non è possibile la commutazione in NOTTE e la funzione GIORNO/NOTTE AUTOMATICO (vedi "19- Impostazione modalità giornaliera" pag. 26).

Nella schermata di riposo dei due centralini dovrà comparire **P**, che indica il centralino configurato in parallelo e l'icona fissa ↗.

- 3- In presenza di 2 centralini principali o secondari che servono il medesimo montante, la configurazione **serie**, implica che solo 1 dei 2 può essere operativo

(**Serie master**), mentre l'altro è disattivo (**Serie slave**) (vedi schema SBTOP/004DSMC pag. 116). Per commutare un centralino da master a slave e viceversa vedi "U11 Come attivare o disattivare i centralini principali" pag. 12.

Nella schermata di riposo dei due centralini dovrà comparire **S**, che indica il centralino configurato in serie e l'icona fissa ↗.

ATTENZIONE!

- se ↗ lampeggia indica che i 2 centralini non comunicano correttamente.

- se compare l'icona ! c'è un problema di configurazione dei 2 centralini (es. entrambi Serie master o slave, Parall. LP-IN o Parall. LS-IN oppure uno serie e l'altro parallelo).

- se in un impianto Simplebus TOP (con scambi Art. 1424), sono presenti sia centralini principali che secondari (vedi schema SBTOP/003DSMC pag. 114); per il corretto funzionamento dell'impianto è necessario attivare su tutti i centralini l'impostazione "C5- Retrocompatibilità" pag. 31.

C2 - Come configurare un centralino principale o secondario

- premere il tasto **MENU** e visualizzare tramite i tasti ▼ ▲ il menu **Configurazioni**, premere il tasto **OK**;

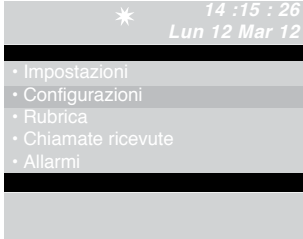

- visualizzare tramite i tasti ▼ ▲ il menu **Sistema**, premere il tasto **OK**;

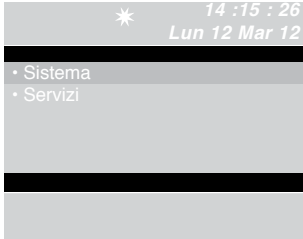

- visualizzare tramite i tasti ▼ ▲ il menu **Sistema**, premere il tasto **OK**;

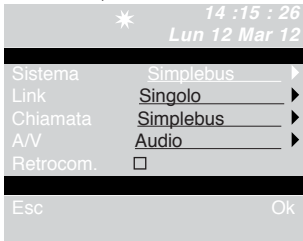

- selezionare Simplebus (per centralino secondario) o Simplebus Top (per centralino principale) con i tasti ◀ ▶.
- premere il tasto **OK** per confermare le impostazioni;
- premere ripetutamente il tasto **ESC** per tornare alla schermata principale.

C3 - Come configurare un centralino come singolo, parallelo o serie

- premere il tasto **MENU** e visualizzare tramite i tasti ▼ ▲ il menu **Configurazioni**, premere il tasto **OK**;

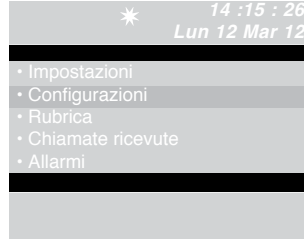

- visualizzare tramite i tasti ▼ ▲ il menu **Sistema**, premere il tasto **OK**;

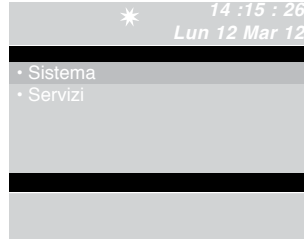

- visualizzare tramite i tasti ▼ ▲ il menu **Link**, premere il tasto **OK**;

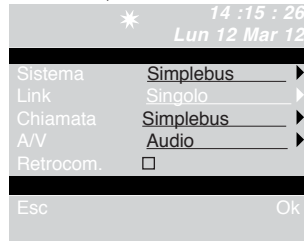

- selezionare **Singolo, Parall. LS-IN, Parall. LP-IN, Serie master, Serie slave** con i tasti ◀ ▶.
- premere il tasto **OK** per confermare le impostazioni;
- premere ripetutamente il tasto **ESC** per tornare alla schermata principale.

C4 - Chiamata tramite codice Simplebus o indiretto

Tramite questa funzione si sceglie la modalità di chiamata manuale del centralino, tra 2 diverse modalità:

- 1- **Chiamata Simplebus (di default)**, la chiamata avviene digitando il codice abbinato ad ogni utente.
- Se il tipo di impianto è **Simplebus** l'utente citofonico è identificato da un campo **Nome Utente** (opzionale) e da un campo **Codice** di 3 cifre massimo (compreso tra 1 e 240).

ESEMPIO: Nome utente = Rossi; **Codice** = 015.

- Nel caso di impianto **Simplebus top** l'utente citofonico è identificato dai campi **Nome Utente** (opzionale) e da un campo **Codice** composto da due parti: campo zona di 3 cifre massimo (compreso tra 1 e 500) e campo utente **tassativamente** di 3 cifre (compreso tra 1 e 240).

ESEMPIO: Nome utente = Rossi; **Codice** = 25 015.

- 2- **Chiamata indiretto**, la chiamata avviene digitando il codice indiretto di 6 cifre massimo. Questo codice deve essere presente in rubrica e associato all'utente provvisto di nome (obbligatorio) e di codice Simplebus (o Simplebus TOP).

Per attivare la funzione:

- premere il tasto **MENU** e visualizzare tramite i tasti ▼ ▲ il menu **Configurazioni**, premere il tasto **OK**;

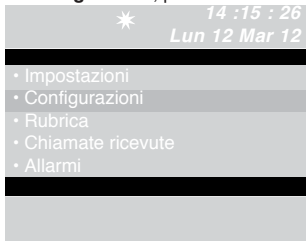

- visualizzare tramite i tasti ▼ ▲ il menu **Sistema**, premere il tasto **OK**;

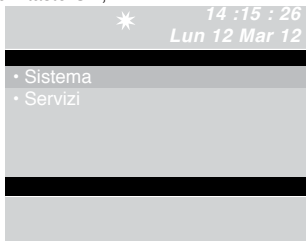

- visualizzare tramite i tasti ▼ ▲ il menu **Chiamata**, premere il tasto **OK**;

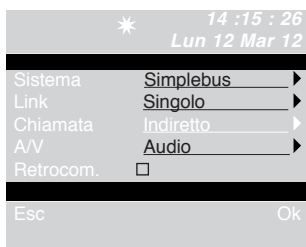

- selezionare Simplebus o Indiretto con i tasti ◀ ▶.
- premere il tasto **OK** per confermare le impostazioni;
- premere ripetutamente il tasto **ESC** per tornare alla schermata principale.

C5 - Retrocompatibilità

È disattivata di default.

ATTENZIONE!

Questa funzione deve essere abilitata per evitare malfunzionamenti nel caso siano presenti articoli con indice di revisione (IR.) inferiore a quelli elencati nella tabella a pag. 32.

Per attivare la funzione:

- premere il tasto **MENU** e visualizzare tramite i tasti ▼ ▲ il menu **Configurazioni**, premere il tasto **OK**;

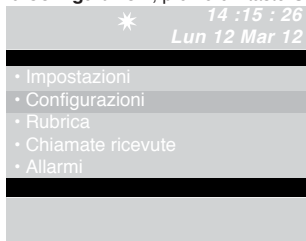

- visualizzare tramite i tasti ▼ ▲ il menu **Sistema**, premere il tasto **OK**;

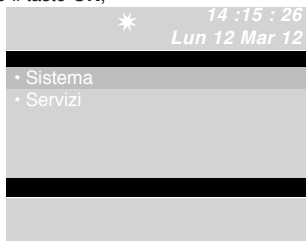

- visualizzare tramite i tasti ▼ ▲ il menu **Retrocom.**, premere il tasto **OK**;

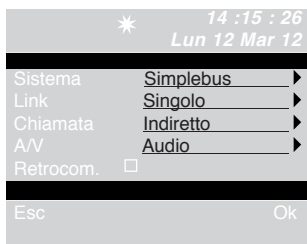

Attivare il servizio Retrocom. con il tasto **▶**.
Disabilitare con **◀**.

- premere il tasto **OK** per confermare le impostazioni;
- premere ripetutamente il tasto **ESC** per tornare alla schermata principale.

C6 - Chiamata audio o video

Chiamata audio di default.

Attivando la chiamata video sarà possibile effettuare una chiamata video verso un posto interno. Il monitor chiamato dal centralino si accenderà consentendo ad es. la visione delle telecamere scorperate abbinata all'Art. 1259/A o all'Art. 1259C (vedi FT/SB/13 o FT/SBC/05).

Con la retrocompatibilità disattivata - di default (vedi C5 - Retrocompatibilità pag. 31), all'atto della chiamata da centralino al posto interno il video si accende immediatamente.

Con la retrocompatibilità attivata, all'atto della chiamata da centralino al posto interno il video si accende su presa fonica.

Per attivare la chiamata audio o video:

- premere il tasto **MENU** e visualizzare tramite i tasti **▼▲** il menu **Configurazioni**, premere il tasto **OK**;

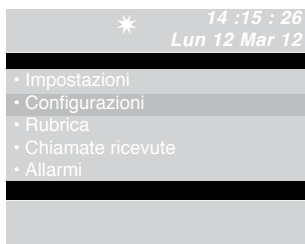

- visualizzare tramite i tasti **▼▲** il menu **Sistema**, premere il tasto **OK**;

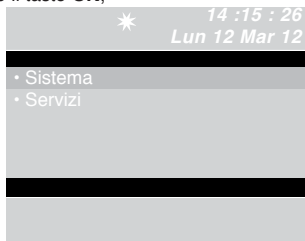

- visualizzare tramite i tasti **▼▲** il menu **A/V**, premere il tasto **OK**;

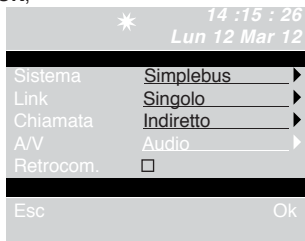

- selezionare **Audio** o **Video** con i tasti **◀▶**.
- premere il tasto **OK** per confermare le impostazioni;
- premere ripetutamente il tasto **ESC** per tornare alla schermata principale.

Tabella articoli Simplebus TOP

Staffe	Art. 5714C IR. 007 - Art. 5814C IR. 002 Art. 6114C IR. 015
Citofoni	Art. 2608 IR. 006 - Art. 2610 IR. 008 Art. 2619 IR. 000 - Art. 2628 IR. 005 Art. 2638 IR. 006
Scambi	Art. 1424 IR. 002
Miscelatori	Art. 4888C IR. 013
Posti esterni	Art. 1602 IR. 027 - Art. 1602VCF IR. 002 Art. 3340 IR. 021 - Art. 3342 IR. 021 Art. 3070/A IR. 010 - Art. 3072/A IR. 010 Art. 4660C IR. 013
Centralini	Art. 1998A IR. 006 - Art. 1998V IR. 001 Art. 1998VC IR. 001
Software	Art. 1249/A IR. 002



C7- Configurazione servizi

FollowMe (“Seguimi”):

È disattivata di default.

ATTENZIONE!

Per l'utilizzo di questa funzione deve essere presente la centrale Art. 2906 con interfaccia Art. 2912. Rivolgersi al proprio installatore di fiducia.

Questa funzione è attivabile solo sul centralino impostato come secondario (vedi “C1 Tipo di centralino” pag. 29).

Tramite questa funzione è possibile deviare le chiamate destinate al centralino verso apparecchi telefonici locali o remoti.

A seguito di una chiamata, il centralino suonerà comunque e finché l'apparecchio remoto non entra in comunicazione, è possibile rispondere alla chiamata dal centralino annullando la funzione “Seguimi”.

Ripetizione di chiamata:

si potrà scegliere la temporizzazione della chiusura del contatto tra 1 e 30 secondi (vedi “I8 - Regolazione tempi” pag. 25).

Accensione interni:

È disattivata di default.

ATTENZIONE!

Questa funzione è disponibile solo per impianti Simplebus non TOP ed è necessaria la presenza dell'Art. 1259 per la visione ciclica di telecamere scorporate.

Tramite questa funzione è possibile attivare o disattivare l'autoaccensione inviata dai posti interni con centralino in modalità GIORNO.

Chiamata tripla:

È disattivata di default.

Tramite questa funzione è possibile attivare o disattivare la chiamata tripla del centralino verso i posti interni.

La chiamata verrà così effettuata 3 volte consecutive (nel caso di chiamata video: le prime 2 saranno audio, la terza sarà video).

Aiuto codici:

È disattivata di default.

Serve per ampliare i codici Simplebus sulla linea montante.

Per attivare i servizi:

- premere il tasto **MENU** e visualizzare tramite i tasti ▼

▲ il menu **Configurazioni**, premere il tasto **OK**;

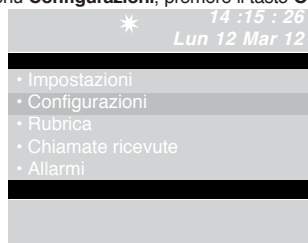

- visualizzare tramite i tasti ▼▲ il menu **Servizi**, premere il tasto **OK**;



- visualizzare tramite i tasti ▼▲ il servizio da attivare (followMe, ripetizione di chiamata, accensione interni, chiamata tripla, aiuto codici).

Attivare il servizio con il tasto ►.

Disabilitare con ◀.

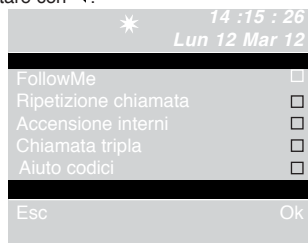

- premere il tasto **OK** per confermare le impostazioni;

- premere ripetutamente il tasto **ESC** per tornare alla schermata principale.

TABLE OF CONTENTS
• INTRODUCTION

- Overall view	35
- Description of terminal block	35
- Programming keys and display	36
- Alphanumeric keypad	36
- General description	36

• USE

U1 How to answer a call from an internal unit	37
U2 How to answer a call from an external unit	37
U3 How to call an internal unit	38
U4 How to transfer a call from the external unit to an internal unit	39
U5 How to set up communication between 2 internal units (intercom function)	39
U6 How to call an internal unit listed in the received calls log	40
U7 How to call a secondary switchboard from a main switchboard	41
U8 How to call a main switchboard from a secondary switchboard	42
U9 How to answer a call made from the secondary switchboard to the main switchboard	42
U10 How to answer a call made from the main switchboard to the secondary switchboard	43
U11 How to activate or deactivate the main switchboards	43
U12 How to use the lock-release	44
U13 How to activate the "Follow Me" function	44
U14 How to activate an additional relay	44

• DIRECTORY

- Tree diagram of DIRECTORY menu screens	45
U15 How to use the directory	45
U16 How to find a name in the directory	45
U17 How to enter a name in the directory	46
U18 How to delete a name in the directory	46
U19 How to edit a name in the directory	47
U20 Delete directory	48
U21 Directory info	48
U22 Record speed numbers	49

• RECEIVED CALLS

- Tree diagram of RECEIVED CALLS menu screens	49
U23 View received calls	49
U24 Delete received calls list	50

• ALARMS

- Tree diagram of ALARMS menu screens	51
U25 View alarms	51
U26 Delete alarms received list	51

• SETTINGS

- Tree diagram of SETTINGS menu screens	52
I1 - Change language	
I2 - Video settings	53
I3 - Audio settings	54
I4 - Tone settings	54
I5 - Change date	55
I6 - Change time	55
I7 - Set skin	56
I8 - Adjust timers (audio, reset wait time, standby, relay activation, call repeat)	56
I9 - Set daily mode	57
I10 - Set automatic switching	57
I11 - Reset settings	58

• INSTALLER CONFIGURATIONS

- Tree diagram of CONFIGURATIONS menu screens	59
- C1 - Type of switchboard (Simplebus Top mode)	60
- C2 - How to configure a main or secondary switchboard	61
- C3 - How to configure a switchboard as single, parallel or series	61
- C4 - Call via Simplebus or indirect code	62
- C5 - Backwards compatibility	62
- C6 - Audio or video call	63
- Table of Simplebus TOP products	63
- C7 - Configure services (FollowMe, call repeat, internal units on, triple call, codes help)	64

• WIRING DIAGRAMS

- SB2V/EN/103M Simplebus B/W video entry phone system with 1 main input and porter switchboard.	96
- SB2V/EN/103SMC Simplebus Color video entry phone system with 1 main input and porter switchboard.	97
- SB2V/EN/105M Simplebus B/W video entry phone system with 2 main inputs and porter switchboard.	98
- SB2V/EN/105SMC Simplebus Color video entry phone system with 2 main inputs and porter switchboard.	99
- SB2V/018ASM Simplebus Color system with remote camera module Art. 1259C in generic actuator mode and porter switchboard.	100
- SB2V/026SMC Video entry phone system with 1 main input and porter switchboard used in conjunction with telephone switchboard Art. 2906 for Follow Me mode.	101
- SB2V/EN/101M Simplebus B/W video entry phone system with 1 main input, 3 secondary video inputs and porter switchboard.	102
- SB2V/EN/101SMC Simplebus Color video entry phone system with 1 main input, 3 secondary video inputs and porter switchboard.	104
- SB2V/EN/121DM Simplebus B/W video entry phone system with 2 main inputs, 3 secondary audio inputs and porter switchboard.	106
- SB2V/EN/121DSMC Simplebus Color video entry phone system with 2 main inputs, 3 secondary audio inputs and porter switchboard.	108
- SBTOP/001DSMC Simplebus TOP video entry phone system with 1 main input, 4 secondary inputs and corresponding secondary porter switchboards.	110
- SBTOP/002DSMC Simplebus TOP video entry phone system with 2 main inputs, 4 secondary inputs and corresponding main porter switchboard.	112
- SBTOP/003DSMC Simplebus TOP video entry phone system with 2 main inputs, 1 main porter switchboard, 2 secondary inputs and corresponding secondary porter switchboards.	114
- SBTOP/004DSMC Simplebus TOP video entry phone system with 1 main input, 4 secondary inputs and 2 main porter switchboards in SERIES configuration.	116
- SBTOP/005DSMC Simplebus TOP video entry phone system with 1 main input, 3 secondary inputs and 2 main porter switchboards in PARALLEL configuration.	118

Overall view

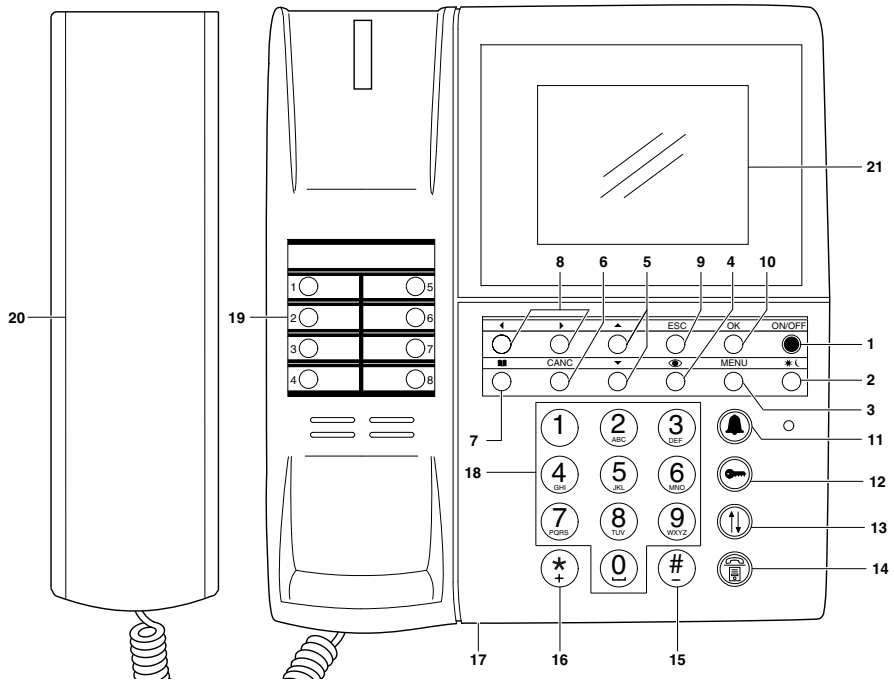

- 1 **ON/OFF** Power on/off (press and hold for 2 seconds)
- 2 ***☾** Key activating DAY or NIGHT mode
- 3 **MENU** key
- 4 **🔊** Key activating self-ignition
- 5 **▼▲** Menu navigation keys
- 6 **CANC** Key used to cancel a call or delete entered data
- 7 **📖** Directory key
- 8 **◀▶** Menu option navigation keys
- 9 **ESC** Exit menu key
- 10 **OK** Confirm key
- 11 **📞** Call key
- 12 **🔒** Lock-release key
- 13 **📞** Follow Me key
- 14 **📞** Call hold key
- 15 **#** Key for calling the Simplebus Top switchboard from the Simplebus switchboard
- 16 ***** Key used to activate an additional relay
- 17 Wheel for call volume adjustment
- 18 Alphanumeric keypad
- 19 **0-9** Speed numbers
- 20 Handset
- 21 Message indication display

Description of terminal block:

C NO Normally open contact for "FOLLOW ME" function

24 ~ 24 V AC power supply

0 ~ 0 V AC power supply

⏏ Earthing

OUT OUT N.O. contact which closes, sending a video call from the switchboard to an internal unit

CH CH Free contact for "call repeat" or "enable external monitor"

LM LM Data line to risers

LP1 LP2 Incoming data line from external unit

GND TX RX RS232 serial port for connection to the remote switchboard in systems with multiple switchboards in series or in parallel.

Programming keys and display

- MENU** To enter the programming menus
- ▼▲ Can be used to select the various menu options
- ◀▶ Can be used to move the cursor in order to change the entered data
- OK** Confirm the displayed information or data entered
- CANC** Delete the data entered
- ESC** Cancel the selected option and exit the programming menu

Switchboard **display** screens:

- 1 **A** AUDIO mode
- ▼ VIDEO mode
- 2 ***** DAY mode
- ☾ NIGHT mode
- 3 **□** indicates audio active
- 4 **☎** indicates "FollowMe" function active
- 5 **:** time (hours:minutes:seconds)
- 6 **:** day (Mon, Tue, etc.) and date (day/month/year)
- 7 **!** the 2 switchboards configured are NOT compatible
- ? the switchboard has not yet detected the presence of the remote switchboard
- 8 **P** indicates that the switchboard is configured in parallel
- S** indicates that the switchboard is configured in series
- 9 **↔** **fixed** indicates correct operation of the serial line
- ↕ **flashing** indicates malfunctioning of the serial line
- 10 **LM flashing** indicates a short circuit on the riser line, the text is accompanied by a tone which sounds repeatedly. The switchboard rejects any attempts to call or transfer calls to internal units; however, all incoming calls from the external unit will be dealt with normally.
- LP flashing** indicates that the external unit is not connected
- 11 **🔔 = 5 flashing** indicates the number of unanswered calls in DAY and NIGHT mode
- 12 **🔔 = 1 flashing** indicates the number of alarms received and not implemented

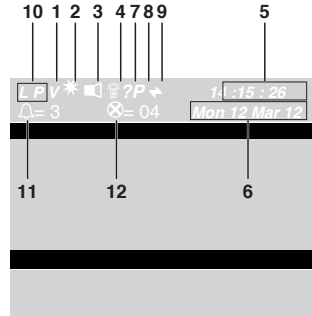

Alphanumeric keypad

For several of the functions, the keypad can be used to enter both numbers and letters; this can be done by pressing the same button several times, for example if you press key 2 several times, a, b, c, A – B - C - 2 will appear in succession.

- ① key for entering symbols .,:;!()
- # key for entering a dash
- * key for entering the + symbol
- ① key for entering a space between characters

- OK** Confirms the data entered
- CANC** Deletes the data entered

General description

The main functions of the switchboard are as follows:

- call an internal unit
- receive calls from external units and transfer them to internal units as necessary
- receive routine or alarm calls from the internal units
- control external unit electric locks
- activate a relay

The porter switchboard also offers:

- DAY/NIGHT operation, which can only be used to enable switchboard functions in specific time bands programmed by the user;
- a CALL LOG, in which the calls from internal units which could not be answered are stored;
- a DIRECTORY which can be programmed so as to identify the caller easily.

USE

The following functions are the main features of the switchboard and its operating mode, which can all be accessed directly without using the menus.

U1 How to answer a call from an internal unit

When the switchboard receives a call from an internal unit:

- the name of the internal unit from which the call is being made, if it is listed in the directory (see "U17 How to enter a name in the directory", page 46), or the address making the call (e.g. 002) is displayed;

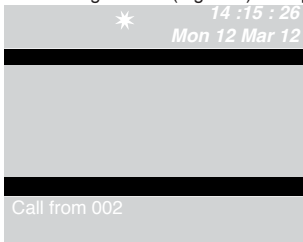

- to **answer** the call originating from the internal unit, lift the handset within 30 seconds;



- the switchboard communicates with the internal unit, with a maximum conversation time equal to the audio time set on the main switchboard (**MENU/Settings/Timers/Audio** - min. 10 seconds, max. 90 seconds).



- to end the conversation, **hang up** the handset;



- to **reject** the call, press **CANC.**

CAUTION!

If the switchboard is busy or the switchboard operator is momentarily absent and cannot answer within 30 seconds, the call will be added to the received call log (see "U6 How to call an internal unit listed in the received call log", page 40).

U2 How to answer a call from an external unit

The switchboard **must** be in DAY mode, in NIGHT mode it will only answer direct switchboard calls.

The switchboard can receive a call from an external unit:

- addressed directly to an internal unit, in which case the NAME of the called unit (if a name in the directory has been assigned to the called code, see "U17 How to enter a name in the directory", page 46) or the address of the called unit (e.g. 002) is displayed;

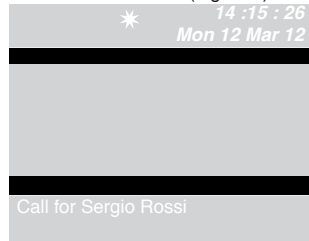

- or addressed directly to the switchboard (address=240);

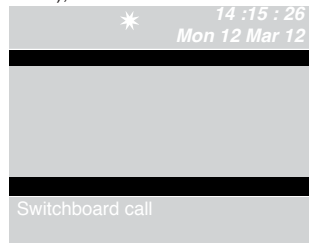

- to **answer** the call coming from the external unit, lift the handset;



- the switchboard communicates with outside;

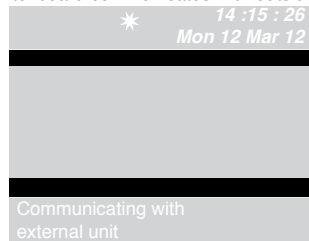

- press key  if necessary, to activate external unit electric lock; if the lock-release takes place, a confirmation tone sounds;



- to end the conversation, **hang up** the handset;



- to **reject** the call, press **CANC.**

CAUTION!

In **NIGHT mode** (see “19 - Set daily mode”, page 57), **calls from the external unit addressed to an internal unit appear on the display, but cannot be intercepted from the switchboard.**





U3 How to call an internal unit

The switchboard can use 3 different methods to call an internal unit:

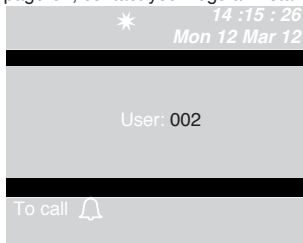
- enter the internal unit number* and press .

*The number entered depends on the switchboard configuration, see “C4 - Call via Simplebus or indirect code”, page 62; contact your regular installer.



- press  and scroll through the directory using the   keys until the desired name is displayed and press .



- press the corresponding **speed number** (e.g.  speed number 1= stored code “002”, see “U22 Record speed numbers”, page 49);

- if the call has taken place correctly:



- if the call has not taken place correctly:

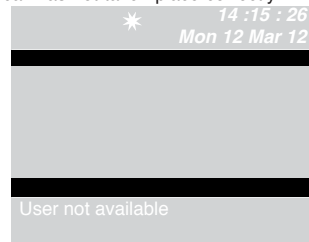

- if the internal unit is busy:

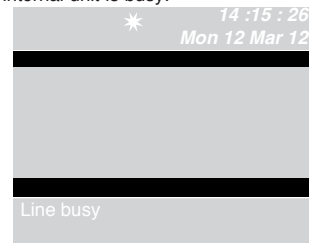

When the **internal unit called enters audio mode**, it communicates with the switchboard, the maximum duration of the conversation is equal to the audio time set on the main switchboard (**MENU/Settings/Timers/Audio** - min. 10 seconds, max. 90 seconds).

U4 How to transfer a call from the external unit to an internal unit

When the switchboard receives a call from an external unit, directed to an internal unit:

- the NAME of the call recipient appears (if a name has been assigned to the corresponding code in the directory, see "U17 How to enter a name in the directory", page 46);

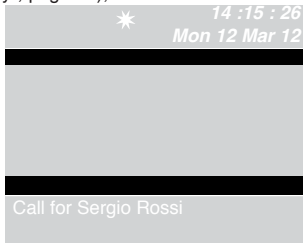

- to **answer** the call originating from the external unit, lift the handset within 60 seconds;



- the switchboard begins communicating with the external unit, the maximum duration of the conversation is 90 seconds;

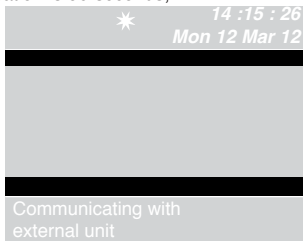

- press  to put the external unit on hold;

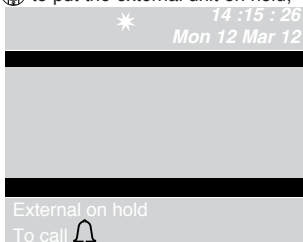

If the internal unit **does not accept** the transferred conversation, the external unit remains on hold; end the conversation with the internal unit and press the  key to re-establish communication with the external unit;

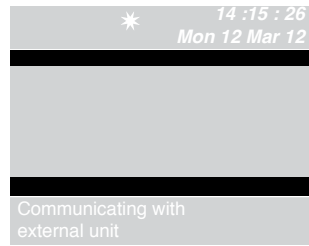

- to end the conversation, **hang up** the handset.



U5 How to set up communication between 2 internal units (intercom function)

When the switchboard is communicating with an internal unit (e.g. 002) which is trying to speak with another internal unit (e.g. 003):

- put the internal unit which is already connected (e.g. 002) on hold by pressing ;

- call the desired internal unit (e.g. 003, see "U3 How to call an internal unit", page 38);

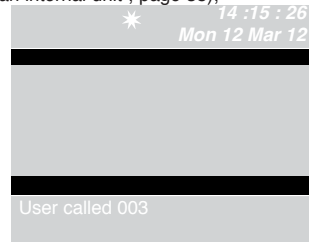

When the **internal unit receiving the call is connected to the audio line**, it begins communicating with the switchboard;

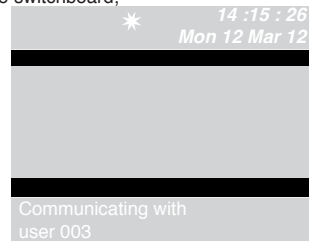

To transfer the conversation to the other internal unit, press ; internal unit (003) begins communicating with internal unit (002); the maximum duration of this communication is 2.5 minutes;

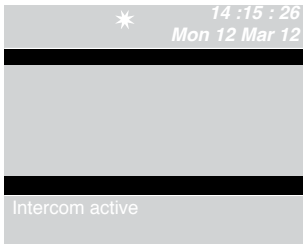



- hang up the handset.

Press **CANC** to reset an intercom call which has been active for more than one minute.

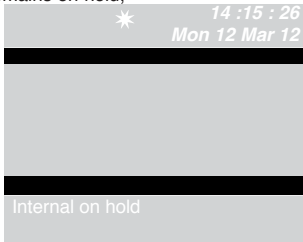

If the internal unit **does not accept** the transferred conversation, or when the **system is busy**, or if the **call has not taken place correctly**, internal unit (002) remains on hold;



- cut off communication with internal unit (003) and press  to resume communication with internal unit (002);



- to end the conversation, **hang up** the handset.



CAUTION!

If the external unit calls the switchboard during an intercom call between internal units which has been underway for more than one minute, the intercom call will be reset so that the switchboard can deal with the incoming call.

U6 How to call an internal unit listed in the received calls log

When the switchboard receives a call from an internal unit and it is not dealt with in the space of 30 sec. (operator momentarily absent or busy with another conversation), this is automatically stored in the **Received calls** menu.

The switchboard can log a maximum of 10 unsuccessful calls. The eleventh call replaces the first.

The display will show the number of the received calls (e.g. =3 flashing).

To call the internal units listed in the received calls log, proceed as follows:

- press the **MENU** key and use the **▼▲** keys to view the **Receivedcalls** menu, press **OK**;

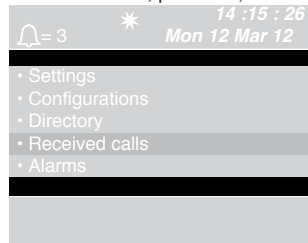

- use the **▼▲** keys to view the **View** entry, press **OK**;

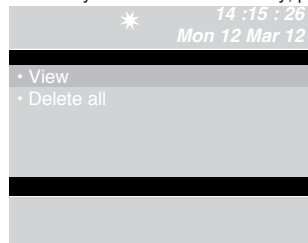

- the calls received and made are displayed in chronological order, beginning with the most recent call received; use the **▼▲** keys to scroll through the list;

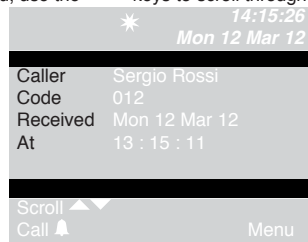

- press  to call the displayed internal unit.

- press the **MENU** key to display a screen in the bottom right-hand corner;

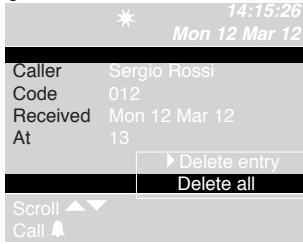

- press **OK** to confirm the settings;





- press **ESC** repeatedly to return to the main screen.

U7 How to call a secondary switchboard from a main switchboard

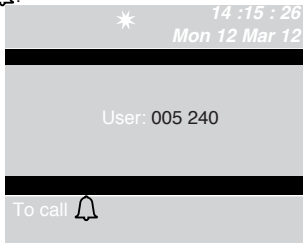
When calling a secondary switchboard, the main switchboard may use one of the 3 following methods:

1 enter the switchboard number (e.g. 005 240) and press :



2 scroll through the directory  using the   keys until the name is displayed and press :

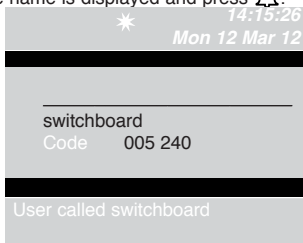

3 press the corresponding **speed number** (see "U22-Record speed numbers", page 49).

- If the call has taken place correctly:

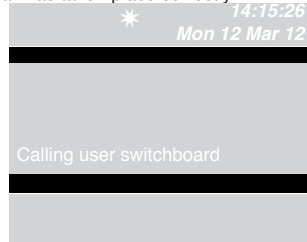

- if the call has not taken place correctly:

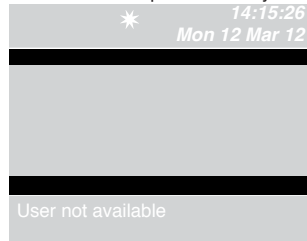

- if the system is busy:

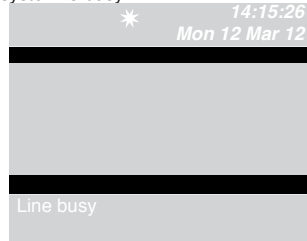

When the **handset of the switchboard called is lifted**, it communicates with the main switchboard, the maximum duration of the conversation is equal to the audio time set on the main switchboard (**MENU/Settings/Timers/Audio** - min. 10 seconds, max. 90 seconds).

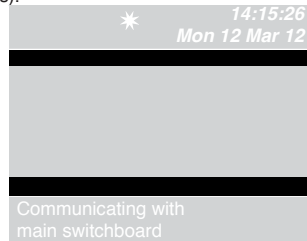

- to end the conversation, **hang up** the handset.



CAUTION!

When the secondary switchboard and main switchboard are communicating with each other, calls cannot be transferred or put on hold.

U8 How to call a main switchboard from a secondary switchboard

To call a main switchboard from a secondary switchboard, press **#**.

When the **handset of the main switchboard called is lifted**, it communicates with the secondary switchboard, the maximum duration of the conversation is equal to the audio time set on the main switchboard (**MENU/Settings/Timers/Audio** - min. 10 seconds, max. 90 seconds).



- to end the conversation, **hang up** the handset.



CAUTION!

When the secondary switchboard and main switchboard are communicating with each other, calls cannot be transferred or put on hold.

U9 How to answer a call made from the secondary switchboard to the main switchboard

When the main switchboard receives a call from the secondary switchboard:

- the NAME of the secondary switchboard from which the call is being made, if it is listed in the directory (see "U17 How to enter a name in the directory", page 46), or the address of the switchboard making the call (e.g. 005 240) is displayed;

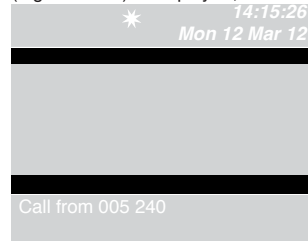

005= indicates the "zone"
240= indicates the general switchboard ID

- to **reject** the call, press **CANC**;
- to **answer** the call coming from the secondary switchboard, lift the handset;



- the main switchboard communicates with the secondary switchboard, with a maximum conversation time equal to the audio time set on the main switchboard (**MENU/Settings/Timers/Audio** - min. 10 seconds, max. 90 seconds);

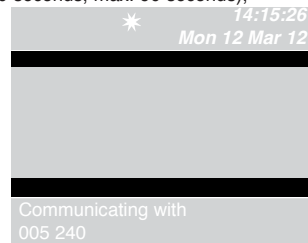

- to end the conversation, **hang up** the handset.



CAUTION!

If the switchboard is busy or the switchboard operator is momentarily absent and cannot answer within 30 seconds, it will be added to the call queue (see "U6 How to call an internal unit listed in the received calls log", page 40).

U10 How to answer a call made from the main switchboard to the secondary switchboard

When the secondary switchboard receives a call from the main switchboard:

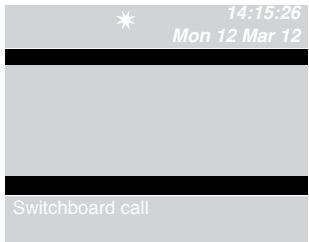

- to **answer** the call coming from the main switchboard, lift the handset;



- to end the conversation, **hang up** the handset.



CAUTION!

If the switchboard is busy or the switchboard operator is momentarily absent and cannot answer within 30 seconds, it will be added to the call queue (see "U6 How to call an internal unit listed in the received calls log", page 40).

U11 How to activate or deactivate the main switchboards

When using 2 main switchboards configured in series (see page 116), use one of the following methods:

1 - press the **MENU** key for the active switchboard and use the **▼▲** keys to view the **Configurations** menu, press **OK**;

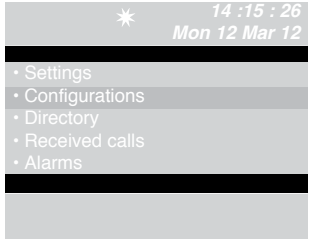

- use the **▼▲** keys to view the **System** menu, press **OK**;

- use the **▼▲** keys to view the **Link** menu, press **OK**;

- select **Slave in series** using the **◀▶** keys to make it inactive.
The switchboard will switch off, while the other switchboard will switch on automatically to become the **Master in series**;

- press **OK** to confirm the settings;
- press **ESC** repeatedly to return to the main screen.
or

1 - press the **MENU** key for the inactive switchboard and use the **▼▲** keys to view the **Configurations** menu, press **OK**;

- use the **▼▲** keys to view the **System** menu, press **OK**;

- use the ▼▲ keys to view the **Link** menu, press **OK**;

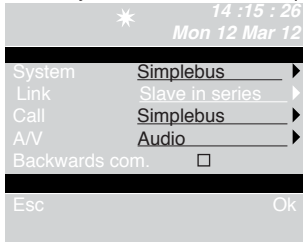

- select the **Master in series** using the ◀▶ keys to confirm that the switchboard should be active. The other switchboard will be deactivated automatically, to become the **Slave in series**;
 - press **OK** to confirm the settings;
 - press **ESC** repeatedly to return to the main screen.

U12 How to use the lock-release

The external unit electric lock can be controlled by pressing key ↵ if the command is executed a confirmation tone sounds.

U13 How to activate the “Follow Me” function (FollowMe)

This function can be used to divert calls for the switchboard to local or remote telephones.

CAUTION!

To use this function, telephone switchboard Art. 2906 and interface Art. 2912 must be fitted. Contact your usual installer.

This function can only activated for the switchboard set as secondary (see “C1 Type of switchboard”, page 60).
 To activate this function:

- press the **MENU** key and use the ▼▲ keys to view the **Configurations** menu, press **OK**;

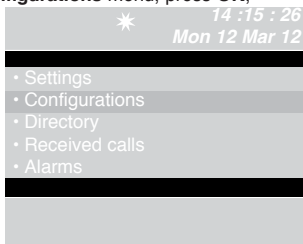

- use the ▼▲ keys to view the **Services** menu, press **OK**;

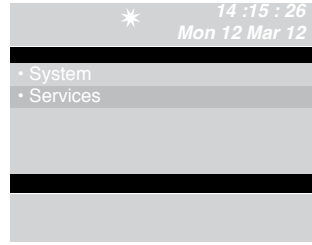

- use the ▼▲ keys to view the **FollowMe** service. Activate the service using the ▶ key. Disable it using ◀;

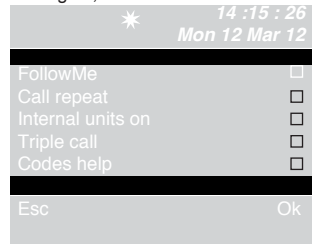

- press **OK** to confirm the settings;
 - press **ESC** repeatedly to return to the main screen.

Once a call has been made, the switchboard will ring until the remote device begins communicating; the call can be answered from the switchboard by cancelling the “Follow me” function.

U14 How to activate an additional relay (e.g. to activate independently using a specific command: lights, CCTV alarm contacts, vehicle barriers, entrances without an external unit or other devices)

Actuators can be activated in standby mode and during conversation with an external unit.

CAUTION!

To use this function, there must be a main external unit and actuators Art. 1256. Contact your usual installer.

To activate the actuator:

- press (*), you will be asked to enter the code to activate a specific actuator. If there is no code a generic actuator will be activated;

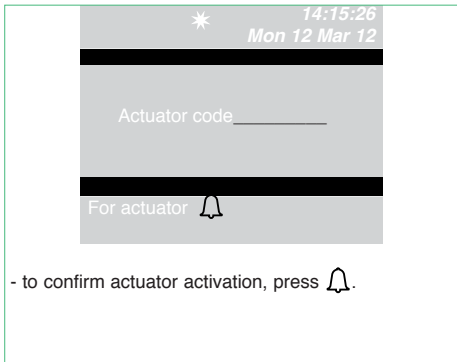

- to confirm actuator activation, press

- use the keys to view the **View** entry, press **OK**;

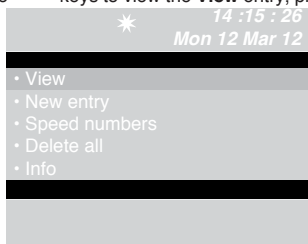

- the names stored in the directory will be displayed in alphabetic order; use the keys to scroll through the list.

To speed up scrolling, press and hold or ;



Or

- enter the name, even using just part of the extension. If there are several users with the same initial, you can scroll through the list using the keys;

- press the **MENU** key to display a screen in the bottom right-hand corner.



A new entry can be added, the selected entry deleted or edited, or the entire directory deleted. Select the desired option using the keys, press **OK**.

- press **ESC** repeatedly to return to the main screen.

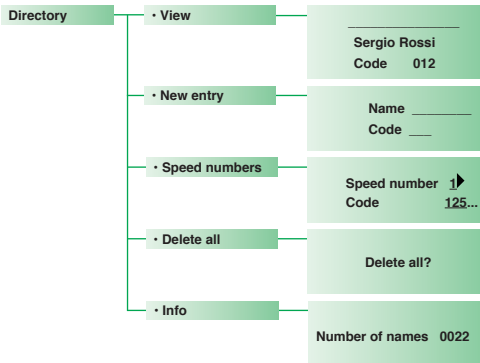

U15 How to use the directory

Up to 4000 names with a maximum of 13 alphanumeric characters can be entered, a code must be associated to each name in correspondence with the desired internal unit.

U16 How to find a name in the directory

To view the directory, press and scroll through the list of users with the keys; press hand hold the key to speed up scrolling. The NAME and CODE associated with each user will be displayed in sequence.

Or

- press the **MENU** key and use the keys to view the **Directory** menu, press **OK**;

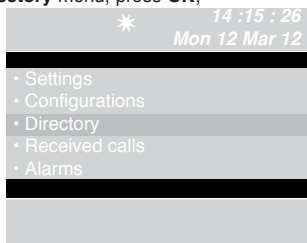

U17 How to enter a name in the directory

If you wish to enter a name in the directory:
 - press the **MENU** key and use the **▼▲** keys to view the **Directory** menu, press **OK**;

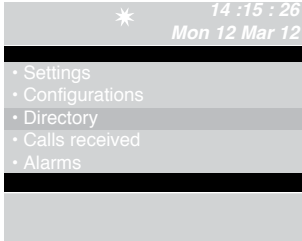

- use the **▼▲** keys to view the **New entry** option, press **OK**;

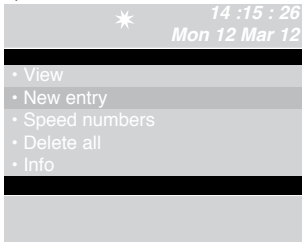

- enter the new name using the alphanumeric keypad;
 press **▼** and enter the code using the keypad;

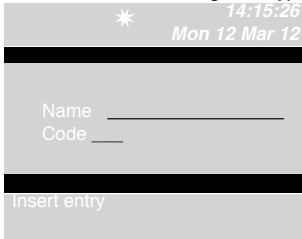

- press **OK** to confirm the settings;

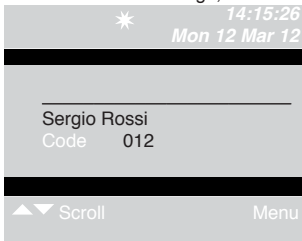

- press the **MENU** key to display a screen in the bottom right-hand corner.

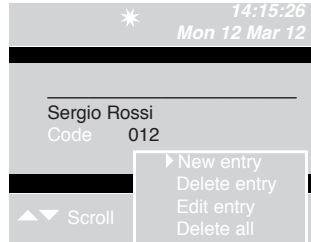

A new entry can be added, the selected entry deleted or edited, or the entire directory deleted.
 Select the desired option using the **▼▲** keys, press **OK**.

- press **ESC** repeatedly to return to the main screen.

U18 How to delete a name in the directory

CAUTION!

To delete the entire directory, see "U20 - Delete directory", page 48.

If you wish to delete a name in the directory:
 - press the **MENU** key and use the **▼▲** keys to view the **Directory** menu, press **OK**;

- use the **▼▲** keys to view the **View** entry, press **OK**;

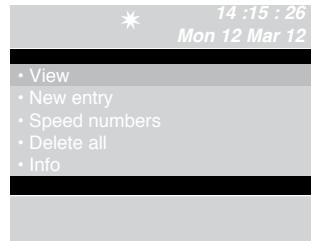

- the names stored in the directory will be displayed in alphabetic order; use the **▼▲** keys to scroll through the list.

To speed up scrolling, press and hold **▼** or **▲**.

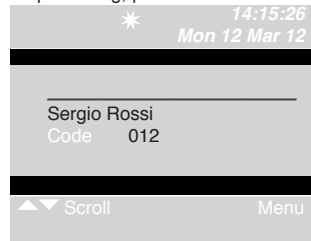

Or

- enter the name, even using just part of the extension;
If there are several users with the same initial, you can scroll through the list using the ▼▲ keys;



- press the **MENU** key to display a screen in the bottom right-hand corner;



- use the ▼ key to view the **Delete entry** option, press **OK**;

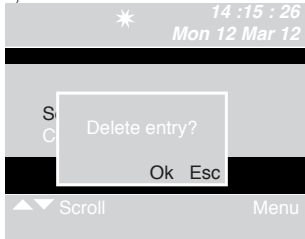

- to confirm deletion press **OK**;
- press **ESC** repeatedly to return to the main screen.

U19 How to edit a name in the directory

If you wish to edit a name in the directory:

- press the **MENU** key and use the ▼▲ keys to view the **Directory** menu, press **OK**;

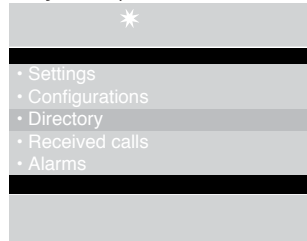

- use the ▼▲ keys to view the **View** entry, press **OK**;

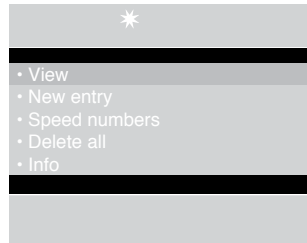

- the names stored in the directory will be displayed in alphabetic order; use the ▼▲ keys to scroll through the list.

To speed up scrolling, press and hold ▼ or ▲.

Or

- enter the name, even using just part of the extension.

If there are several users with the same initial, you can scroll through the list using the ▼▲ keys;

- press the **MENU** key to display a screen in the bottom right-hand corner;



- use the ▼ key to view the **Edit entry** option, press **OK**;



- use the ▼▲ keys to view the entry you wish to edit (name or code);

- press **CANC** to delete the selected entry and enter the new name or code using the alphanumeric keypad;

- to confirm the edited name, press **OK**; press **ESC** to exit.

U20 Delete directory

- press the **MENU** key and use the ▼▲ keys to view the **Directory** menu, press **OK**;

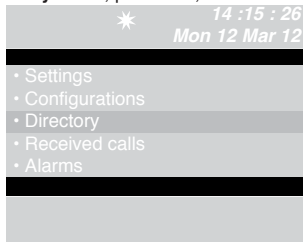

- use the ▼▲ keys to view the **Delete all** option, press **OK**;

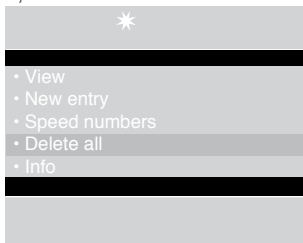

- a screen will appear, asking if you wish to delete the entire directory; confirm using **OK** or cancel using **ESC**;

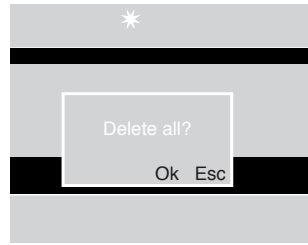

- press **ESC** repeatedly to return to the main screen.

U21 Directory info

- press the **MENU** key and use the ▼▲ keys to view the **Directory** menu, press **OK**;

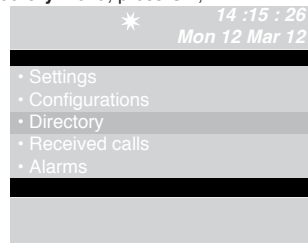

- use the ▼▲ keys to view the **Info** entry, press **OK**;

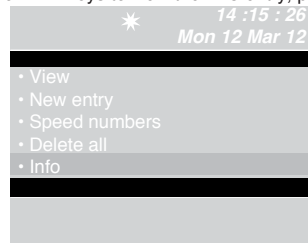

- a screen will appear, indicating the number of names stored in the directory;

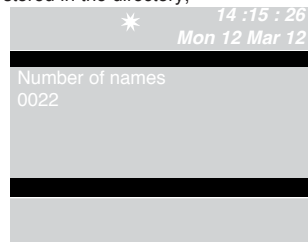

- press **ESC** repeatedly to return to the main screen.

U22 Record speed numbers

This function can be used to store, edit and delete speed numbers.

- press the **MENU** key and use the **▼▲** keys to view the **Directory** menu, press **OK**;

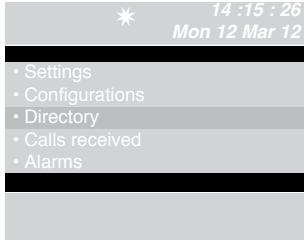

- use the **▼▲** keys to view the **Speed numbers** option, press **OK**;

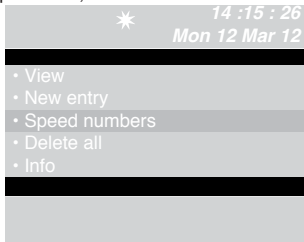

- use the **◀▶** keys to display the speed number (from 1 to 8) to which a code will be assigned;

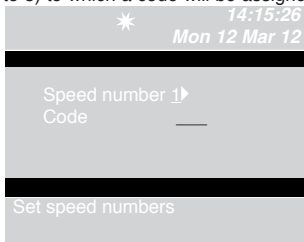

- press **▼** and enter the code using the keypad;

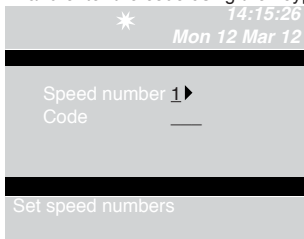

- press **OK** to confirm the settings;
- press **ESC** repeatedly to return to the main screen.

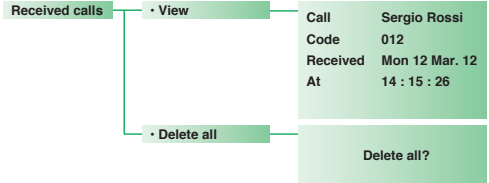

U23 - View received calls

- To access the received calls quickly, press **MENU + key 2** or press **MENU** and use the **▼▲** keys to view the **Received calls** menu , press **OK**;

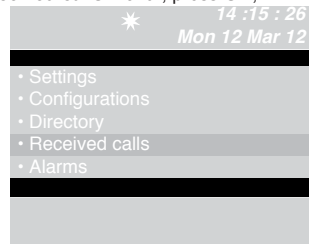

- use the **▼▲** keys to view the **View** entry, press **OK**;

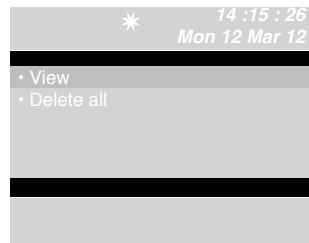

- the calls received and made are displayed in chronological order, beginning with the most recent call received; use the **▼▲** keys to scroll through the list.

To speed up scrolling, press and hold **▼** or **▲**;

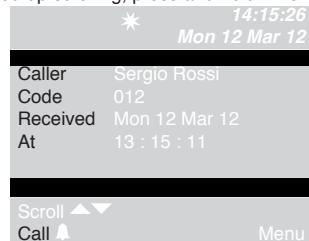

- press the **MENU** key to display a screen in the bottom right-hand corner.

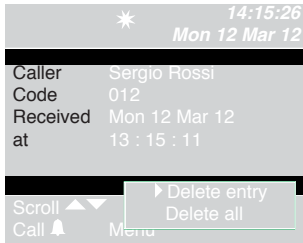

- press **OK** to confirm the settings;
 - press **ESC** repeatedly to return to the main screen.

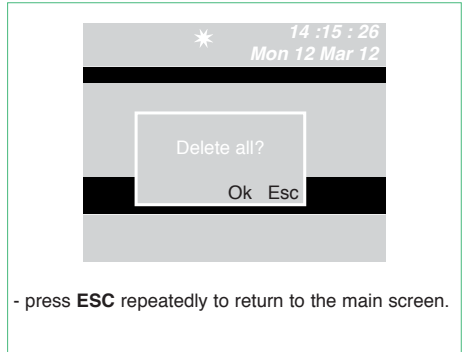

- press **ESC** repeatedly to return to the main screen.

U24 - Delete received calls list

- press the **MENU** and use the ▼▲ keys to view the **Received calls** menu, press **OK**;

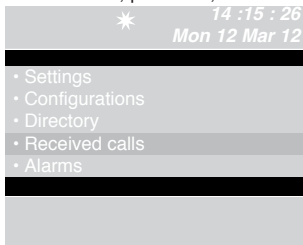

- use the ▼▲ keys to view the **Delete all** option, press **OK**;

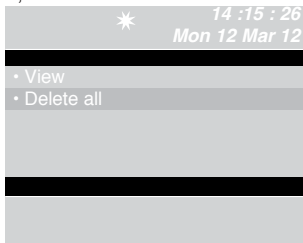

- a screen will appear, asking if you wish to delete the list of incoming calls; confirm using **OK** or cancel using **ESC**;

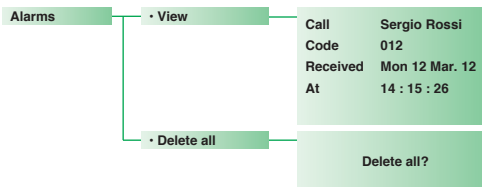

U25 - View alarms

- To access alarm viewing mode quickly, press **MENU** + key 1, or press **MENU** and use the **▼▲** keys to view the **Alarms** menu, press **OK**;

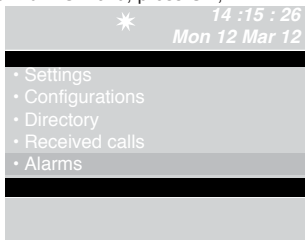

- use the **▼▲** keys to view the **View** entry, press **OK**;

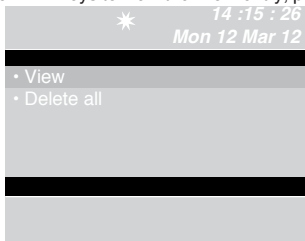

- the calls are displayed in chronological order, beginning with the most recent call received; use the **▼▲** keys to scroll through the list.

To speed up scrolling, press and hold **▼** or **▲**;

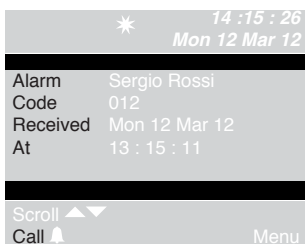

- press the **MENU** key to display a screen in the bottom right-hand corner;

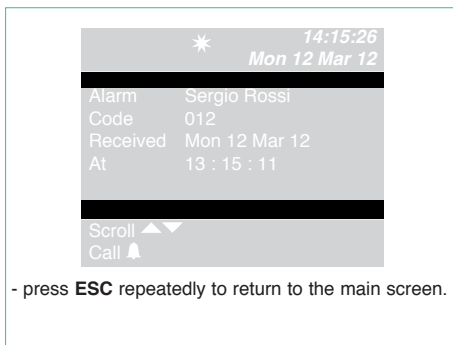

- press **ESC** repeatedly to return to the main screen.

U26 - Delete alarms received list

- press the **MENU** key and use the **▼▲** keys to view the **Alarms** menu, press **OK**;

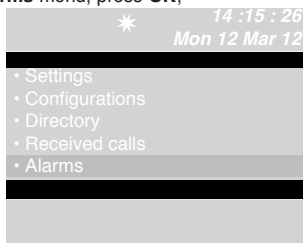

- use the **▼▲** keys to view the **Delete all** option, press **OK**;

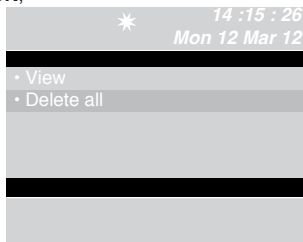

- a screen will appear, asking if you wish to delete the list of incoming alarms; confirm using **OK** or cancel using **ESC**;

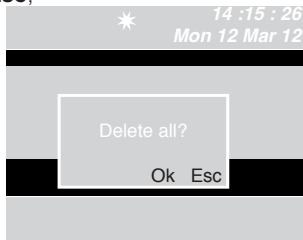

- press **ESC** repeatedly to return to the main screen.

SETTINGS

EN

Settings

• Language

- ▶ Italiano
- English
- Français
- Deutsch
- Español
- Portuguese
- Dutch
- Danish
- Norwegian
- Finnish
- Swedish
- Turkish
- Russian
- Polish
- Croatian

• Video

Brightness

Contrast

Colour

• Audio

- Internal
- External

Microphone

Loudspeaker

• Tones

External Spring ▶

Internal Spring ▶

Alarm Alarm 1 ▶

Key tone

• Date

Year ◀ 2010 ▶

Month ◀ March ▶

Day ◀ 12 ▶

• Time

Hours ◀ 14 ▶

Minutes ◀ 15 ▶

Seconds ◀ 26 ▶

• Skins

Skins Blue skin ▶

◀ Planux skin ▶ ◀ Green skin ▶

◀ Red skin ▶ ◀ Yellow skin ▶

◀ Pink skin ▶ ◀ Orange skin ▶

• Timers

Audio 010 ▶

Reset wait time 01 ▶

Standby 010 ▶

Relay activation 01 ▶

Call repeat 01 ▶

• Daily mode

Enable

Sun Night ▶ Wed Night ▶

Mon Night ▶ Thur Night ▶

Tue Night ▶ Fri Night ▶

Sat Night ▶

• Automatic switching

Swt 1 00 ▶ : 00 ▶ ◀ Day ▶

Swt 2 00 ▶ : 00 ▶ ◀ Night ▶

Swt 3 00 ▶ : 00 ▶ ◀ Day ▶

Swt 4 00 ▶ : 00 ▶ ◀ Day ▶

• Reset settings

Reset?

I1 - Change language

The switchboard language can be selected from the following list:

► **Italiano (default)**

- English
- Français
- Deutsch
- Español
- Portuguese
- Dutch
- Danish
- Norwegian
- Finnish
- Swedish
- Turkish
- Russian
- Polish
- Croatian

- press the **MENU** key and use the ▼▲ keys to view the **Settings** menu, press **OK**;

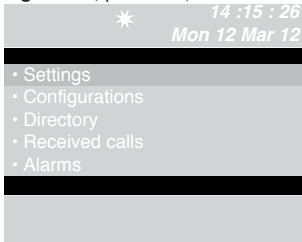

- use the ▼▲ keys to view the **Language** menu, press **OK**;

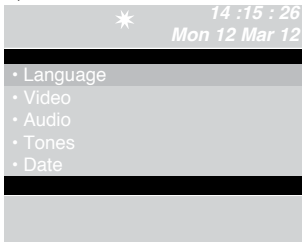

- use the ▼▲ keys to view the selected language, press **OK** to confirm;
- press **ESC** repeatedly to return to the main screen.



I2 - Video settings

This function can be used to adjust the brightness, contrast and colour of the switchboard monitor.

- To access the video settings quickly, press **MENU** + key **3**, or press **MENU** and use the ▼▲ keys to view the **Settings** menu, press **OK**;

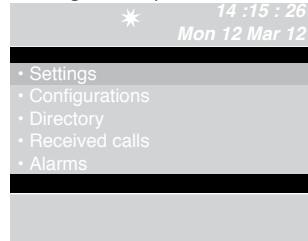

- use the ▼▲ keys to view the **Video** menu, press **OK**;

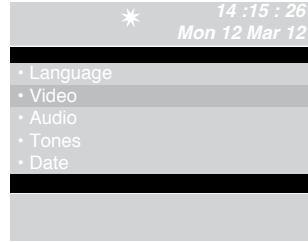

- use the ▼▲ keys to view the video setting you wish to adjust (brightness, contrast, colour) and decrease or increase the value using the ◀▶ keys;

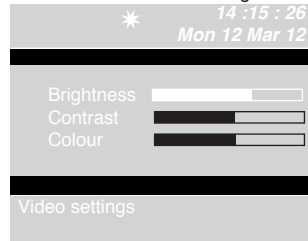

- press **OK** to confirm the settings;
- press **ESC** repeatedly to return to the main screen.

I3 - Audio settings

This function can be used to adjust the volume of the switchboard microphone and loudspeaker as it communicates with the internal units and the external unit.

N.B. For volume adjustment to take place, the switchboard must be in communication with the internal unit or the external unit.

- To access the audio settings quickly, press **MENU** + key 4 (**external**), key 5 (**internal**) or press **MENU** and use the **▼▲** keys to view the **Settings** menu, press **OK**;

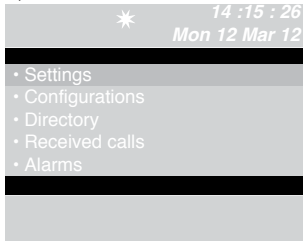

- use the **▼▲** keys to view the **Audio** menu, press **OK**;

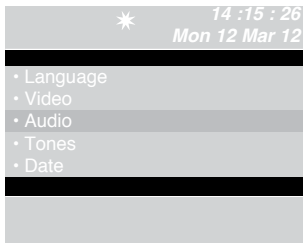

- use the **▼▲** keys to view the audio setting you wish to adjust (internal and/or external), press **OK**;

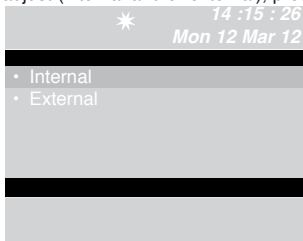

- use the **▼▲** keys to view the audio setting you wish to adjust (microphone and/or loudspeaker) and decrease or increase the value using the **◀▶** keys;

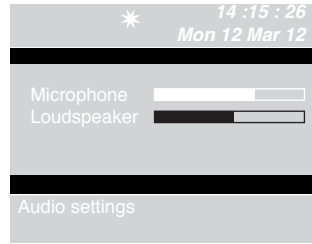

- press **OK** to confirm the settings;
- press **ESC** repeatedly to return to the main screen.

I4 - Tone settings

This function can be used to set the melody for incoming calls made from the internal units, and the external unit, as well as alarm calls; it is also possible to activate or deactivate the key tone.

- press the **MENU** key and use the **▼▲** keys to view the **Settings** menu, press **OK**;

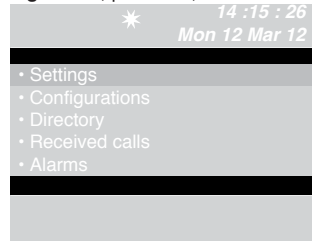

- use the **▼▲** keys to view the **Tones** menu, press **OK**;

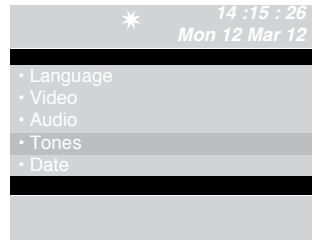

- use the **▼▲** keys to view the tone you wish to adjust (external, internal, alarm or key tone);

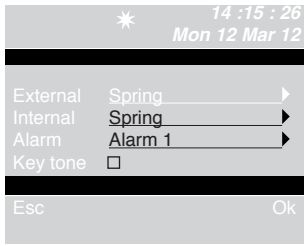

- select the melody using the ◀▶ keys.
- Activate the Tone service using the ▶ key.
- Disable it using ◀;
- press **OK** to confirm the settings;
- press **ESC** repeatedly to return to the main screen.

15 - Change date

- press the **MENU** key and use the ▼▲ keys to view the **Settings** menu, press **OK**;

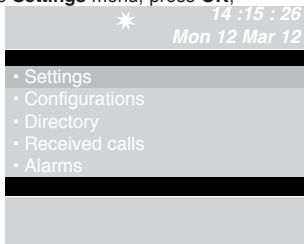

- use the ▼▲ keys to view the **Date** menu, press **OK**;



- use the ▼▲ keys (year, month, day) and change it using the ◀▶ keys;

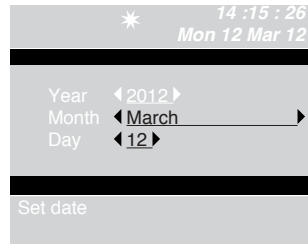

- press **OK** to confirm the settings;
- press **ESC** repeatedly to return to the main screen.

16 - Change time

- press the **MENU** key and use the ▼▲ keys to view the **Settings** menu, press **OK**;

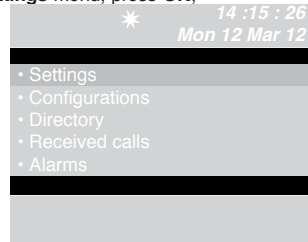

- use the ▼▲ keys to view the **Time** menu, press **OK**;

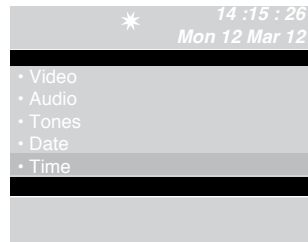

- use the ▼▲ keys (hours, minutes, seconds) and decrease or increase the value using the ◀▶ keys;

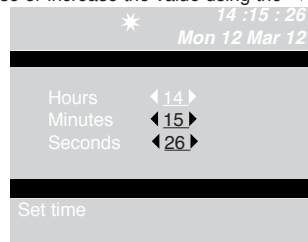

- press **OK** to confirm the settings;
- press **ESC** repeatedly to return to the main screen.

17 - Set skin

This function can be used to change the colour of the menu screens.

- press the **MENU** key and use the **▼▲** keys to view the **Settings** menu, press **OK**;

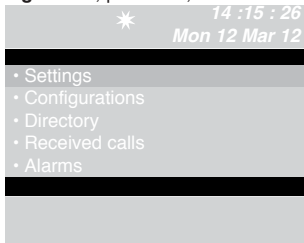

- use the **▼▲** keys to view the **Skins** menu, press **OK**;

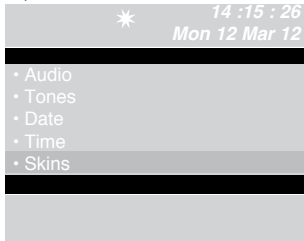

- use the **◀▶** keys to select the desired skin;

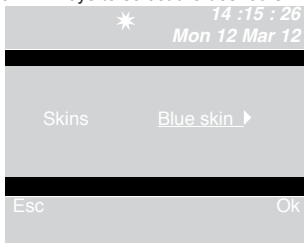

- press **OK** to confirm the setting;
- press **ESC** repeatedly to return to the main screen.

18 - Adjust timers

This function can be used to set the audio, reset wait time, standby, relay activation and call repeat timers.

- press the **MENU** key and use the **▼▲** keys to view the **Settings** menu, press **OK**;

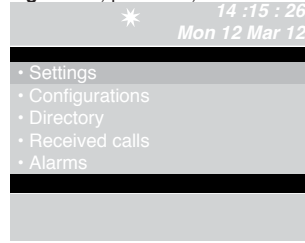

- use the **▼▲** keys to view the **Timers** menu, press **OK**;

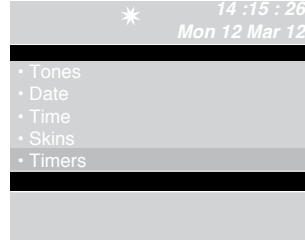

- use the **▼▲** keys to view the setting you wish to adjust (audio, reset wait time, standby, relay activation, call repeat) and decrease or increase the value using the **◀▶** keys.

To speed up scrolling, press and hold **◀** or **▶**.

Audio values: 10"-180" max.

Reset wait time values: 1"-10" max.

Standby values: 10"-120" max.

Relay activation values: 1"-20" max.

Call repeat values: 1"-30" max;

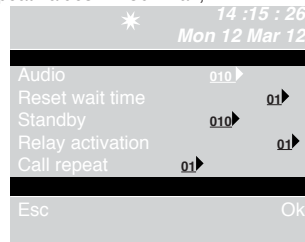

- press **OK** to confirm the settings;
- press **ESC** repeatedly to return to the main screen.

I9 - Set daily mode

You can decide to organise the week by selecting one of these 3 operating modes for each day:

- **AUTO:** the system passes from DAY mode to NIGHT mode at the programmed times.
 - **NIGHT:** the system is in this mode for the whole day.
 - **DAY:** the system is in this mode for the whole day.
- If the "auto" setting is selected, throughout the day the operating mode will switch at pre-set times, on the basis of the programming set in accordance with paragraph "I10 - Set automatic switching" on page 57.

To deactivate the function, press \odot .*
To activate it:

- press the **MENU** key and use the \blacktriangledown / \blacktriangle keys to view the **Settings** menu, press **OK**;

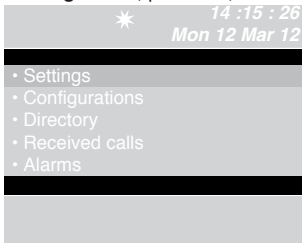

- use the \blacktriangledown / \blacktriangle keys to view the **Daily mode** menu, press **OK**;

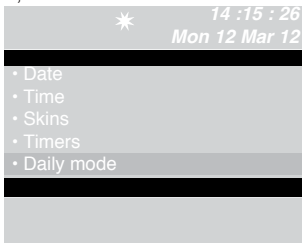

- use the \blacktriangledown / \blacktriangle keys to view the day to be set and select night, day or auto mode using the \blacktriangleleft / \blacktriangleright keys;

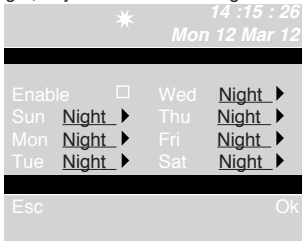

- once programming for each day of the week is

complete, select **Enable** and activate the whole

- programming schedule using \blacktriangleright , to disable use \blacktriangleleft ;
- press **OK** to confirm the settings;
- press **ESC** repeatedly to return to the main screen.

I10 - Set automatic switching

The system can be set to allow automatic passage from DAY mode to NIGHT mode at specific times which can be programmed by the user. Up to 4 TIMETABLES can be set, and switching mode will be set for each on (Day or Night).

Example:

You want to configure the switchboard with the following parameters:

- 07:00 - 12:00 Day mode operation
- 13:00 - 22:00 Day mode operation

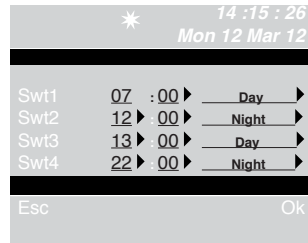

- press the **MENU** key and use the \blacktriangledown / \blacktriangle keys to view the **Settings** menu, press **OK**;

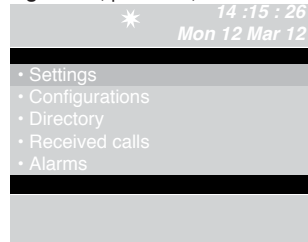

- use the \blacktriangledown / \blacktriangle keys to view the **Automatic switching** menu, press **OK**;

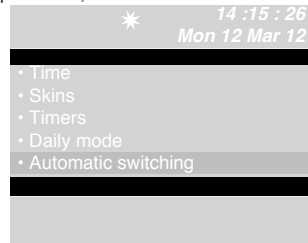

- the cursor will automatically be positioned on the min. time for switching 1; decrease or increase the value using

the ◀▶ keys.

The value ranges from 00 to 23.

To speed up scrolling, press and hold ◀ or ▶;

- select the value, in minutes, of switching 1 using ▼, decrease or increase the value using the ◀▶ keys.

The value ranges from 00 to 59.

To speed up scrolling, press and hold ◀ or ▶;

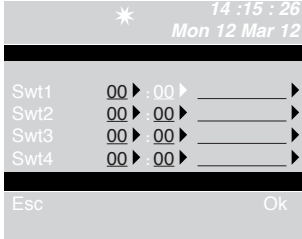

- select the last entry for switching 1 using ▼, select the mode (day, night) using the ◀▶ keys;

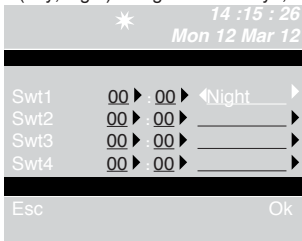

- follow the procedure described up to this point for all necessary switching procedures;

- press **OK** to confirm the settings;

- press **ESC** repeatedly to return to the main screen.

I11 - Reset settings

- press the **MENU** key and use the ▼▲ keys to view the **Settings** menu, press **OK**;

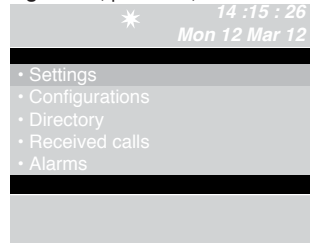

- use the ▼▲ keys to view the **Reset settings** menu, press **OK**;

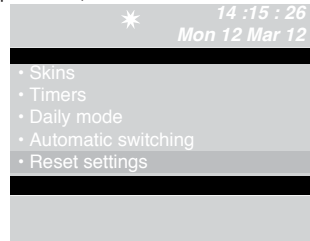

- a screen will appear, asking if you wish to reset the settings; confirm using **OK** or cancel using **ESC**;

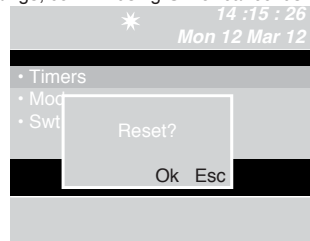

- if you press **OK**, the system reboot screen will appear;

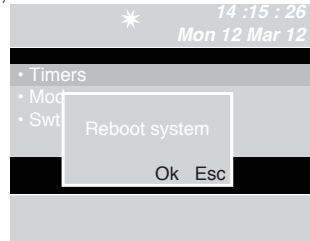

- confirm the system reboot using **OK** or cancel using **ESC**;

- press **ESC** repeatedly to return to the main screen.

INSTALLER CONFIGURATIONS

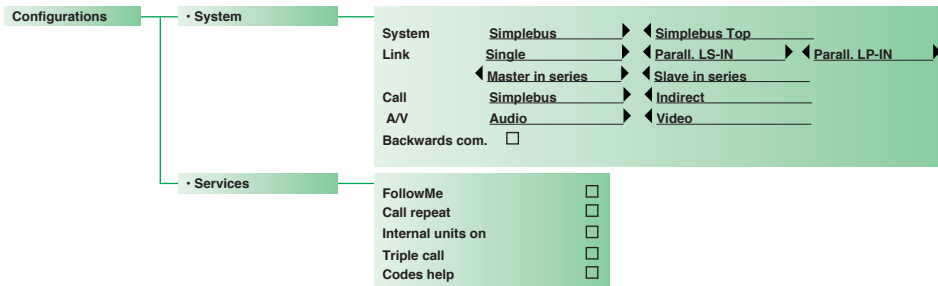

EN

INSTALLER CONFIGURATIONS

This section is aimed at qualified technicians who, after installing the product, will program the porter switchboard using guided menus, which can be viewed on the display by navigating the main menu.

C1 - Type of switchboard (Simplebus Top mode)

The switchboard may be secondary or main.

- Set **Simplebus** when the switchboard is used as secondary, as output from the LM-LM terminals of switching devices Art. 1424 (Simplebus TOP system) (see SBTOP/001DSMC diagram, page 110); or when the switchboard is used in Simplebus systems with switching devices Art. 1224A or in a system with a single riser and no switching devices. **CAUTION!** the secondary switchboard cannot be configured as a switchboard in parallel.
- Set **Simplebus top** when the switchboard is used as main in a Simplebus top system, and therefore positioned upline of switching devices Art. 1424 marking the zones/risers (see SBTOP/002DSMC diagram, page 112).

The secondary or main switchboard must then be configured as:

- 1- SINGLE
- 2- PARALLEL
- 3- SERIES

1- Select **single** when the switchboard is the only one in the system, or the only one serving a specific riser.

2- If there are 2 main or secondary switchboards serving the same riser, the **parallel** configuration means that both switchboards will be operating with the same functions (see SBTOP/005DSMC diagram, page 118).

The first of the two to answer a call will preclude the possibility of the other one performing the same procedure.

If one of the 2 devices is switched on or off, the other will automatically follow suit.

Set the switchboard connected under the LS-LS line of switching device Art. 1424 as **Parall. LS-IN**; set the switchboard located under the LPin-LPin line of switching device Art. 1424 as **Parall. LP-IN**.

For the parallel switchboard, switching to NIGHT and the AUTOMATIC DAY/NIGHT function is not possible (see "I9- Set daily mode", page 57).

A **P** should appear on the standby screen of the two switchboards, indicating that the switchboard is configured in parallel, in addition to the fixed icon .

3- If there are 2 main or secondary switchboards serving the same riser, the **series** configuration means that only 1 of the 2 can operate at one time

(**Master in series**), while the other is deactivated (**Slave in series**) (see SBTOP/004DSMC diagram, page 116).

To change a switchboard from master to slave and vice-versa, see "U11 How to activate or deactivate the main switchboards", page 43.

An **S** should appear on the standby screen of the two switchboards, indicating that the switchboard is configured in series, in addition to the fixed icon .

CAUTION!

- if  flashes, it is indicating that the 2 switchboards are not communicating correctly.

- if the icon ! appears, there is a problem with the configuration of the 2 switchboards (e.g. both master or slave in series, Parall. LP-IN or Parall. LS-IN or one in series and the other parallel).

- if in a Simplebus TOP system (with switching devices Art. 1424), both main and secondary switchboards are present (see SBTOP/003DSMC diagram page 114); for correct system operation the setting "C5- Backwards compatibility", page 62, must be activated on all switchboards.

(IT) Tabella di programmazione dei dip switch.

(FR) Tableau de programmation des DIP switches.

(EN) Dip switch programming table.

Codice/ Code	Dip switch ON	Nome/Name	Codice/ Code	Dip switch ON	Nome/Name
1	1		31	1,2,3,4,5	
2	2		32	6	
3	1,2		33	1,6	
4	3		34	2,6	
5	1,3		35	1,2,6	
6	2,3		36	3,6	
7	1,2,3		37	1,3,6	
8	4		38	2,3,6	
9	1,4		39	1,2,3,6	
10	2,4		40	4,6	
11	1,2,4		41	1,4,6	
12	3,4		42	2,4,6	
13	1,3,4		43	1,2,4,6	
14	2,3,4		44	3,4,6	
15	1,2,3,4		45	1,3,4,6	
16	5		46	2,3,4,6	
17	1,5		47	1,2,3,4,6	
18	2,5		48	5,6	
19	1,2,5		49	1,5,6	
20	3,5		50	2,5,6	
21	1,3,5		51	1,2,5,6	
22	2,3,5		52	3,5,6	
23	1,2,3,5		53	1,3,5,6	
24	4,5		54	2,3,5,6	
25	1,4,5		55	1,2,3,5,6	
26	2,4,5		56	4,5,6	
27	1,2,4,5		57	1,4,5,6	
28	3,4,5		58	2,4,5,6	
29	1,3,4,5		59	1,2,4,5,6	
30	2,3,4,5		60	3,4,5,6	

Codice/ Code	Dip switch ON	Nome/Name	Codice/ Code	Dip switch ON	Nome/Name
61	1,3,4,5,6		91	1,2,4,5,7	
62	2,3,4,5,6		92	3,4,5,7	
63	1,2,3,4,5,6		93	1,3,4,5,7	
64	7		94	2,3,4,5,7	
65	1,7		95	1,2,3,4,5,7	
66	2,7		96	6,7	
67	1,2,7		97	1,6,7	
68	3,7		98	2,6,7	
69	1,3,7		99	1,2,6,7	
70	2,3,7		100	3,6,7	
71	1,2,3,7		101	1,3,6,7	
72	4,7		102	2,3,6,7	
73	1,4,7		103	1,2,3,6,7	
74	2,4,7		104	4,6,7	
75	1,2,4,7		105	1,4,6,7	
76	3,4,7		106	2,4,6,7	
77	1,3,4,7		107	1,2,4,6,7	
78	2,3,4,7		108	3,4,6,7	
79	1,2,3,4,7		109	1,3,4,6,7	
80	5,7		110	2,3,4,6,7	
81	1,5,7		111	1,2,3,4,6,7	
82	2,5,7		112	5,6,7	
83	1,2,5,7		113	1,5,6,7	
84	3,5,7		114	2,5,6,7	
85	1,3,5,7		115	1,2,5,6,7	
86	2,3,5,7		116	3,5,6,7	
87	1,2,3,5,7		117	1,3,5,6,7	
88	4,5,7		118	2,3,5,6,7	
89	1,4,5,7		119	1,2,3,5,6,7	
90	2,4,5,7		120	4,5,6,7	

Codice/ Code	Dip switch ON	Nome/Name	Codice/ Code	Dip switch ON	Nome/Name
121	1,4,5,6,7		151	1,2,3,5,8	
122	2,4,5,6,7		152	4,5,8	
123	1,2,4,5,6,7		153	1,4,5,8	
124	3,4,5,6,7		154	2,4,5,8	
125	1,3,4,5,6,7		155	1,2,4,5,8	
126	2,3,4,5,6,7		156	3,4,5,8	
127	1,2,3,4,5,6,7		157	1,3,4,5,8	
128	8		158	2,3,4,5,8	
129	1,8		159	1,2,3,4,5,8	
130	2,8		160	6,8	
131	1,2,8		161	1,6,8	
132	3,8		162	2,6,8	
133	1,3,8		163	1,2,6,8	
134	2,3,8		164	3,6,8	
135	1,2,3,8		165	1,3,6,8	
136	4,8		166	2,3,6,8	
137	1,4,8		167	1,2,3,6,8	
138	2,4,8		168	4,6,8	
139	1,2,4,8		169	1,4,6,8	
140	3,4,8		170	2,4,6,8	
141	1,3,4,8		171	1,2,4,6,8	
142	2,3,4,8		172	3,4,6,8	
143	1,2,3,4,8		173	1,3,4,6,8	
144	5,8		174	2,3,4,6,8	
145	1,5,8		175	1,2,3,4,6,8	
146	2,5,8		176	5,6,8	
147	1,2,5,8		177	1,5,6,8	
148	3,5,8		178	2,5,6,8	
149	1,3,5,8		179	1,2,5,6,8	
150	2,3,5,8		180	3,5,6,8	

Codice/ Code	Dip switch ON	Nome/Name	Codice/ Code	Dip switch ON	Nome/Name
181	1,3,5,6,8		211	1,2,5,7,8	
182	2,3,5,6,8		212	3,5,7,8	
183	1,2,3,5,6,8		213	1,3,5,7,8	
184	4,5,6,8		214	2,3,5,7,8	
185	1,4,5,6,8		215	1,2,3,5,7,8	
186	2,4,5,6,8		216	4,5,7,8	
187	1,2,4,5,6,8		217	1,4,5,7,8	
188	3,4,5,6,8		218	2,4,5,7,8	
189	1,3,4,5,6,8		219	1,2,4,5,7,8	
190	2,3,4,5,6,8		220	3,4,5,7,8	
191	1,2,3,4,5,6,8		221	1,3,4,5,7,8	
192	7,8		222	2,3,4,5,7,8	
193	1,7,8		223	1,2,3,4,5,7,8	
194	2,7,8		224	6,7,8	
195	1,2,7,8		225	1,6,7,8	
196	3,7,8		226	2,6,7,8	
197	1,3,7,8		227	1,2,6,7,8	
198	2,3,7,8		228	3,6,7,8	
199	1,2,3,7,8		229	1,3,6,7,8	
200	4,7,8		230	2,3,6,7,8	
201	1,4,7,8		231	1,2,3,6,7,8	
202	2,4,7,8		232	4,6,7,8	
203	1,2,4,7,8		233	1,4,6,7,8	
204	3,4,7,8		234	2,4,6,7,8	
205	1,3,4,7,8		235	1,2,4,6,7,8	
206	2,3,4,7,8		236	3,4,6,7,8	
207	1,2,3,4,7,8		237	1,3,4,6,7,8	
208	5,7,8		238	2,3,4,6,7,8	
209	1,5,7,8,...		239	1,2,3,4,6,7,8	
210	2,5,7,8		*240	5,6,7,8	*1998/A

C2 - How to configure a main or secondary switchboard

- press the **MENU** key and use the **▼▲** keys to view the **Configurations** menu, press **OK**;

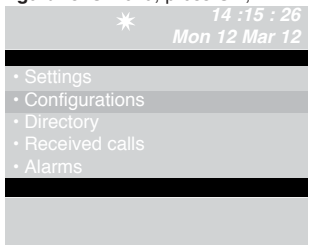

- use the **▼▲** keys to view the **System** menu, press **OK**;

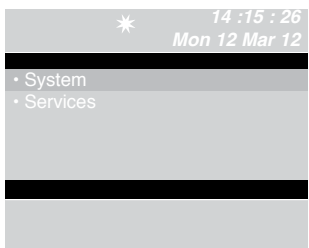

- use the **▼▲** keys to view the **System** menu, press **OK**;

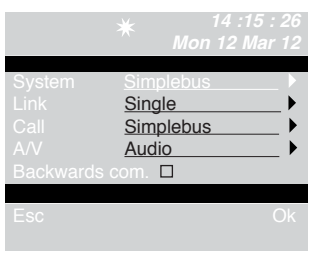

- select Simplebus (for secondary switchboard) or Simplebus Top (for main switchboard) using the **◀▶** keys;
 - press **OK** to confirm the settings;
 - press **ESC** repeatedly to return to the main screen.

C3 - How to configure a switchboard as single, parallel or series

- press the **MENU** key and use the **▼▲** keys to view the **Configurations** menu, press **OK**;

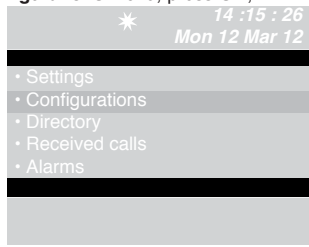

- use the **▼▲** keys to view the **System** menu, press **OK**;

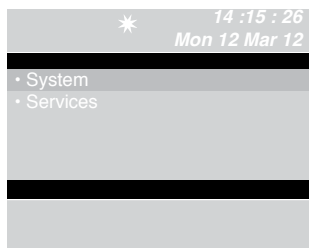

- use the **▼▲** keys to view the **Link** menu, press **OK**;

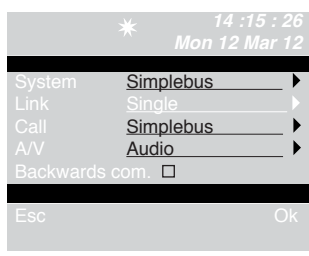

- select **Single, Parall. LS-IN, Parall. LP-IN, Master in series, Slave in series** using the **◀▶** keys;
 - press **OK** to confirm the settings;
 - press **ESC** repeatedly to return to the main screen.

C4 - Call via Simplebus or indirect code

This function can be used to select the manual switchboard calling mode, from the 2 options available:

1- Simplebus call (default), the call is made by entering the code corresponding to each user.

- If the system is a **Simplebus** type, the door-entry phone user is identified by a **User Name** field (optional) and a **Code** field no longer than 3 digits (between 1 and 240).

EXAMPLE: User name = Smith; Code = 015.

- If using a **Simplebus top** system, the door-entry phone user is identified by the **User Name** field (optional) and a **Code** field consisting of 2 parts, a zone field with up to 3 digits (between 1 and 500) and a user field **which must** have 3 digits (between 1 and 240).

EXAMPLE: User name = Smith; Code = 25 015.

2- Indirect call, the call is made by entering the indirect code, which should have a maximum of 6 digits. This code must be stored in the memory and associated with the user who has been given a name (compulsory) and Simplebus (or Simplebus TOP code).

To activate the function:

- press the **MENU** key and use the **▼▲** keys to view the **Configurations** menu, press **OK**;

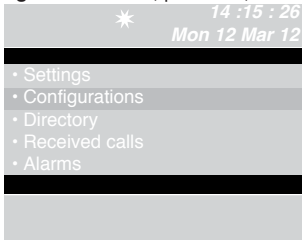

- use the **▼▲** keys to view the **System** menu, press **OK**;

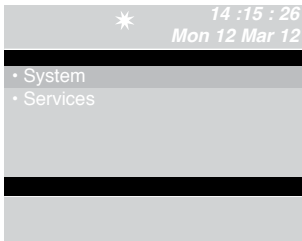

- use the **▼▲** keys to view the **Call** menu, press **OK**;

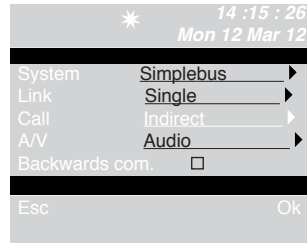

- select Simplebus or Indirect using the **◀▶** keys;
- press **OK** to confirm the settings;
- press **ESC** repeatedly to return to the main screen.

C5 - Backwards compatibility

This is disabled by default.

CAUTION!

This function must be enabled to prevent malfunctioning if there are items with a revision index (R.I.) lower than those listed in the table on page 63.

To activate the function:

- press the **MENU** key and use the **▼▲** keys to view the **Configurations** menu, press **OK**;

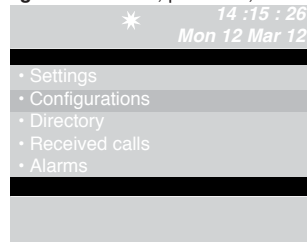

- use the **▼▲** keys to view the **System** menu, press **OK**;

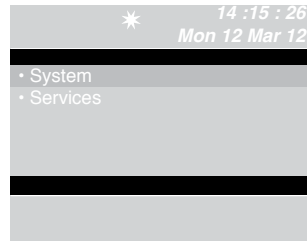

- use the **▼▲** keys to view the **Backwards com.** menu, press **OK**;

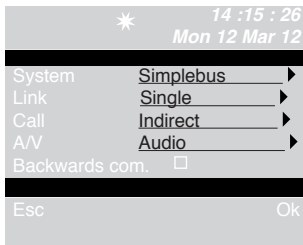

Activate the Backwards com. service using the **▶** key. Disable it using **◀**;

- press **OK** to confirm the settings;
- press **ESC** repeatedly to return to the main screen.

C6 - Audio or video call

Audio call by default.

Activating video calling will allow you to make a video call to an internal unit. The monitor called by the switchboard will switch on, making it possible to view, for example, the images from the remote cameras connected to Art. 1259/A or Art. 1259C (see FT/SB/13 or FT/SBC/05).

When backwards compatibility is deactivated (see C5 - Backwards compatibility, page 62), when the internal unit receives a call from the switchboard, the video comes on immediately by default.

When backwards compatibility is activated, when the internal unit receives a call from the switchboard, the video comes on when the handset is lifted.

To activate audio or video calling:

- press the **MENU** key and use the **▼▲** keys to view the **Configurations** menu, press **OK**;

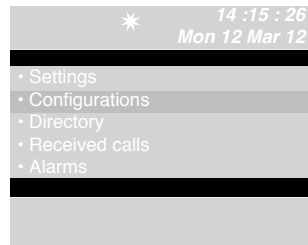

- use the **▼▲** keys to view the **System** menu, press **OK**;

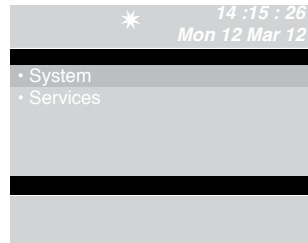

- use the **▼▲** keys to view the **A/V** menu, press **OK**;

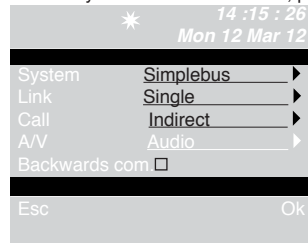

- select **Audio** or **Video** using the **◀▶** keys;
- press **OK** to confirm the settings;
- press **ESC** repeatedly to return to the main screen.

Table of Simplebus TOP products

Brackets	Art. 5714C R.I. 007 - Art. 5814C R.I. 002 Art. 6114C R.I. 015
Door-entry phones	Art. 2608 R.I. 006 - Art. 2610 R.I. 008 Art. 2619 R.I. 000 - Art. 2628 R.I. 005 Art. 2638 R.I. 006
Switching devices	Art. 1424 R.I. 002
Mixers	Art. 4888C R.I. 013
External units	Art. 1602 R.I. 027 - Art. 1602VCF R.I. 002 Art. 3340 R.I. 021 - Art. 3342 R.I. 021 Art. 3070/A R.I. 010 - Art. 3072/A R.I. 010 Art. 4660C R.I. 013
Switchboards	Art. 1998A R.I. 006 - Art. 1998V R.I. 001 Art. 1998VC R.I. 001
Software	Art. 1249/A R.I. 002



C7- Configure services

FollowMe:

This is disabled by default.

CAUTION!

To use this function, telephone switchboard Art. 2906 and interface Art. 2912 must be fitted. Contact your usual installer.

This function can only activated for the switchboard set as secondary (see "C1 Type of switchboard", page 60).

This function can be used to divert calls for the switchboard to local or remote telephones.

Once a call has been made, the switchboard will ring until the remote device begins communicating; the call can be answered from the switchboard by cancelling the "Follow me" function.

Call repeat:

timed contact closure between 1 and 30 seconds can be selected (see "I8 - Adjust timers", page 56).

Internal units on:

This is disabled by default.

CAUTION!

This function is only available for non-TOP Simplebus systems and requires Art. 1259 for the cyclic displaying of images from remote cameras.

This function can be used to activate or deactivate the self-ignition transmitted by the internal units with the switchboard in DAY mode.

Triple call:

This is disabled by default.

This function can be used to activate or deactivate the triple call made by the switchboard to the internal units.

The call will therefore take place on consecutive occasions (in the case of video calls: the first will be audio calls and the third will be a video call).

Codes help:

This is disabled by default.

It is used to expand the Simplebus codes on the riser line.

To activate the services:

- press the **MENU** key and use the **▼▲** keys to view the **Configurations** menu, press **OK**;

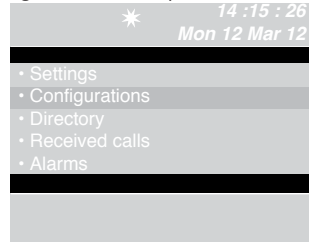

- use the **▼▲** keys to view the **Services** menu, press **OK**;

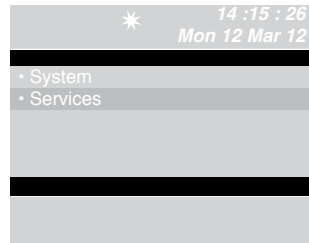

- use the **▼▲** keys to view the service you wish to activate (FollowMe, call repeat, internal units on, triple call, codes help).

Activate the service using the **▶** key.

Disable it using **◀**;

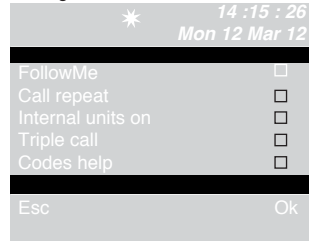

- press **OK** to confirm the settings;

- press **ESC** repeatedly to return to the main screen.

SOMMAIRE

- INTRODUCTION

- Vue générale	66
- Description bornier	66
- Touches de programmation et afficheur	67
- Clavier alphanumérique	67
- Description générale	67

- UTILISATION

U1 Comment répondre à un appel d'un poste intérieur	68
U2 Comment répondre à un appel d'une platine extérieure	68
U3 Comment appeler un poste intérieur	69
U4 Comment passer un appel de la platine extérieure au poste intérieur	70
U5 Comment mettre en communication 2 postes intérieurs (fonction intercommunicante)	70
U6 Comment appeler un poste intérieur présent dans les appels reçus	71
U7 Comment appeler un standard secondaire depuis le standard principal	72
U8 Comment appeler le standard principal depuis un standard secondaire	73
U9 Comment répondre à un appel du standard secondaire au standard principal	73
U10 Comment répondre à un appel du standard principal au standard secondaire	74
U11 Comment activer ou désactiver les standards principaux	74
U12 Comment utiliser l'ouvre-porte	75
U13 Comment activer la fonction « Suivi » (FollowMe)	75
U14 Comment activer un relais supplémentaire	75

- RÉPERTOIRE

- Arbre des pages menu RÉPERTOIRE	76
U15 Comment utiliser le répertoire	76
U16 Comment chercher un nom en répertoire	76
U17 Comment insérer un nom au répertoire	77
U18 Comment effacer un nom du répertoire	77
U19 Comment modifier un nom en répertoire	78
U20 Effacer le répertoire	79
U21 Info répertoire	79
U22 Enregistrement numéros brefs	80

- APPELS REÇUS

- Arbre des pages menu APPELS REÇUS	80
U23 Affichage appels reçus	80
U24 Effacement liste des appels reçus	81

- ALARMES

- Arbre des pages menu ALARMES	82
U25 Affichage alarmes	82
U26 Effacement liste alarmes reçues	82

- RÉGLAGES

- Arbre des pages menu RÉGLAGES	83
I1 - Modifier langue	84
I2 - Réglages vidéo	84
I3 - Réglages audio	85
I4 - Réglages sons	85
I5 - Modifier date	86
I6 - Modifier heure	86
I7 - Réglage thème	87
I8 - Réglage des temps (phonie, attente de reset, veille, activation relais, répétition d'appel)	87
I9 - Réglage modalité quotidienne	88
I10 - Réglage commut. automatique	88
I11 - Reset des réglages	89

- CONFIGURATIONS INSTALLATEUR

- Arbre des pages menu CONFIGURATIONS	90
- C1 - Type de standard (mode Simplebus Top)	91
- C2 - Comment configurer un standard principal ou secondaire	92
- C3 - Comment configurer un standard simple, en parallèle ou en série	92
- C4 - Appel via code Simplebus ou indirect	93
- C5 - Rétrocompatibilité	93
- C6 - Appel audio ou vidéo	94
- Tableau articles Simplebus TOP	94
- C7 - Configuration services (FollowMe, répétition d'appel, allumage postes intérieurs, appel triple, aide codes)	95

- SCHÉMAS DE CONNEXION

- SB2V/EN/103M Installation visiophonique Simplebus n/b avec 1 entrée principale et standard de conciergerie.	96
- SB2V/EN/103M Installation visiophonique Simplebus couleurs avec 1 entrée principale et standard de conciergerie.	97
- SB2V/EN/105M Installation visiophonique Simplebus n/b avec 2 entrées principales et standard de conciergerie.	98
- SB2V/EN/105SMC Installation visiophonique Simplebus couleurs avec 2 entrées principales et standard de conciergerie.	99
- SB2V/018ASMC Installation Simplebus couleurs avec module caméra déportée art. 1259C en modalité actionneur générique avec standard de conciergerie	100
- SB2V/026SMC Installation visiophonique avec 1 entrée principale et standard de conciergerie associé au standard téléphonique art. 2906 pour follow-me.	101
- SB2V/EN/101M Installation visiophonique Simplebus n/b avec 1 entrée principale, 3 secondaires vidéo et standard de conciergerie.	102
- SB2V/EN/101SMC Installation visiophonique Simplebus couleurs avec 1 entrée principale, 3 secondaires vidéo et standard de conciergerie.	104
- SB2V/EN/121DM Installation visiophonique Simplebus n/b avec 2 entrées principales, 3 secondaires audio et standard de conciergerie.	106
- SB2V/EN/121DSMC Installation visiophonique Simplebus couleurs avec 2 entrées principales, 3 secondaires audio et standard de conciergerie.	108
- SBTOP/001DSMC Installation visiophonique Simplebus TOP avec 1 entrée principale, 4 secondaires et standards de conciergerie secondaires correspondants.	110
- SBTOP/002DSMC Installation visiophonique Simplebus TOP avec 2 entrées principales, 4 secondaires et standard de conciergerie principal.	112
- SBTOP/003DSMC Installation visiophonique Simplebus TOP avec 2 entrées principales, 1 standard de conciergerie principal, 2 secondaires et standards de conciergerie secondaires correspondants.	114
- SBTOP/004DSMC Installation visiophonique Simplebus TOP avec 1 entrée principale, 4 secondaires et 2 standards de conciergerie principaux en configuration SÉRIE.	116
- SBTOP/005DSMC Installation visiophonique Simplebus TOP avec 1 entrée principale, 3 secondaires et 2 standards de conciergerie principaux en configuration PARALLÈLE.	118

Vue générale

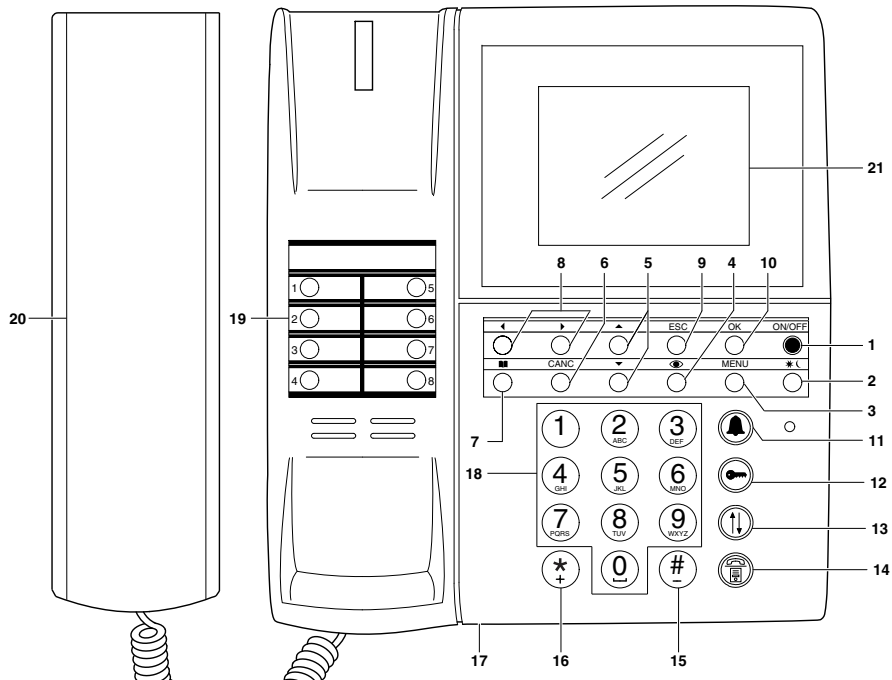

- 1 **ON/OFF** Allumage/extinction (Appuyer dessus 2 secondes)
- 2 *** / ☾** Touche validant la modalité JOUR ou NUIT
- 3 Touche **MENU**
- 4 **☉** Touche validant l'auto-allumage
- 5 **▼ / ▲** Touches de déroulement menus.
- 6 **CANC** Touche d'annulation appel ou effacement données saisies
- 7 **☰** Touche répertoire
- 8 **◆** Touches de déroulement des options de menu
- 9 **ESC** Touche de sortie des menus
- 10 **OK** Touche confirmation
- 11 **📞** Touche pour envoi appel
- 12 **🚪** Touche pour ouvre-porte
- 13 **📞** Touche pour transfert d'appel
- 14 **📞** Touche pour mettre un appel en attente
- 15 **#** Touche pour appeler le standard Simplebus
Top du standard Simplebus
- 16 *** / *** Touche pour activer un relais supplémentaire
- 17 Potentiomètre de réglage du volume de la sonnerie.
- 18 **1-9, 0, *** Clavier alphanumérique
- 19 **1-9** Numéros brefs
- 20 Combiné
- 21 Afficheur signalisation messages

Description bornier :

- C NO** Contact normalement ouvert pour fonction « SUIVI » (Follow me))
- 24~** Alimentation 24V CA
- 0~** Alimentation 0V CA
- ⏚** Mise à la terre
- OUT OUT** Contact normalement ouvert qui se ferme en envoyant un appel vidéo du standard vers un poste intérieur
- CH CH** Contact libre pour « répétition d'appel » ou « validation moniteur extérieur »
- LM LM** Ligne données vers les montants
- LP1 LP2** Ligne données venant de la platine extérieure
- GND TX RX** Série rs232 à connecter au standard à distance sur les installations à plusieurs standards en série ou en parallèle.

Touches de programmation et afficheur

MENUS	Pour entrer dans les menus de programmation
▼▲	Permettent de sélectionner les différentes options des menus
◀▶	Permettent de déplacer le curseur pour modifier les données saisies
OK	Confirmation de la sélection visualisée ou de la saisie données
CANC	Effacement des données saisies
ESC	Annulation de la sélection et sortie des menus de programmation

Visualisations par **afficheur** du standard :

- 1 **A** modalité AUDIO
- V** modalité VIDÉO
- 2 ***** modalité JOUR
- ☾** modalité NUIT
- 3 **☎** indique la phonie validée
- 4 **📞** indique la fonction « FollowMe » validée
- 5 heure (heures:minutes:secondes)
- 6 nom du jour (Lun, Mar, etc.) et date (jour/mois/année)
- 7 **!** on a une configuration entre les 2 standards NON compatible
- ? le standard n'a pas encore relevé la présence du standard à distance
- 8 **P** indique le standard configuré en parallèle
- S** indique le standard configuré en série
- 9 **↔** **fixe** indique le fonctionnement correct de la ligne série
- ↔** **clignotant** indique le dysfonctionnement de la ligne série
- 10 **LM clignotant** indique un court-circuit sur la ligne montant, l'inscription est accompagnée par la répétition d'une tonalité. Le standard refuse tout essai d'appel ou de transfert de l'appel vers les postes intérieurs ; au contraire, tous les appels arrivant de la platine extérieure sont gérés normalement.
- LP clignotant** indique que la platine extérieure n'est pas connectée
- 11 **🔔** =5 **clignotant** indique le nombre d'appels sans réponse en modalité JOUR et NUIT
- 12 **⊗** =1 **clignotant** indique le nombre d'alarmes reçues et non résolues

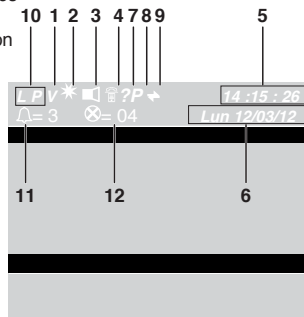

Clavier alphanumérique

Pour certaines fonctions, le clavier permet de saisir des chiffres et des lettres ; il suffit d'appuyer plusieurs fois sur la même touche, par exemple en appuyant sur la touche 2, on aura en succession sur l'afficheur a, b, c, A - B - C - 2 ;

- ① touche pour saisir les symboles .,:;!()
- # touche pour saisir un tiret
- * touche pour saisir le symbole +
- ① touche pour ajouter un espace entre les caractères
- OK** Confirmation des données saisies
- CANC** Effacement des données saisies

Description générale

Les fonctions principales du standard sont les suivantes :

- appeler un poste intérieur
- recevoir des appels des platines extérieures et les transmettre éventuellement aux postes intérieurs
- recevoir des appels ordinaires ou d'alarme des postes intérieurs
- commander la gâche électrique des platines extérieures
- activer un relais

Le standard de conciergerie prévoit également :

- une gestion JOUR/NUIT qui permet de valider les fonctions du standard uniquement dans des tranches horaires déterminées programmables par l'utilisateur ;
- une LISTE D'APPELS dans laquelle sont mémorisés les appels provenant des postes intérieurs auxquels il n'a pas été possible de répondre ;
- un RÉPERTOIRE dont la programmation permet d'identifier facilement l'utilisateur appelant.

UTILISATION

Les fonctions suivantes sont celles qui caractérisent le standard et son mode d'opérer ; elles sont toutes accessibles en mode direct sans avoir besoin de recourir aux menus.

U1 Comment répondre à un appel d'un poste intérieur

Lorsque le standard reçoit un appel d'un poste intérieur :

- le nom du poste intérieur d'où provient l'appel est visualisé, s'il a été saisi dans le répertoire (voir « U17 Comment insérer un nom au répertoire » page 77) ou l'adresse de l'appelant (ex. 002).

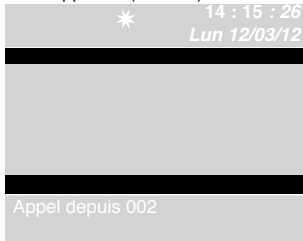

- pour **répondre** à l'appel provenant du poste intérieur, soulever le combiné dans les 30 secondes ;



- le standard entre en communication avec le poste intérieur, la durée maximum de la conversation correspond au temps de phonie programmé sur le standard principal (**MENU/Réglages/Temps/Phonie** - min. 10 secondes, max. 90 secondes).



- **raccrocher** pour terminer la conversation.



- pour **refuser** l'appel, appuyer sur **CANC**.

ATTENTION !

Si le standard est occupé ou le/la standardiste est momentanément absent/e et ne peut pas répondre dans les 30 secondes, l'appel sera inséré dans les appels reçus, voir « U6 Comment appeler un poste intérieur présent dans les appels reçus » page 71.

U2 Comment répondre à un appel d'une platine extérieure

Le standard **doit** être en modalité JOUR, en modalité NUIT il ne pourra répondre qu'aux appels adressés au standard.

Le standard peut recevoir un appel d'une platine extérieure :

- adressé directement à un poste intérieur, dans ce cas, le NOM de l'appelé s'affiche (si le répertoire contient un nom associé au code appelé, voir « U17 Comment saisir un nom au répertoire » page 77) ou l'adresse de l'appelé (par ex. 002).

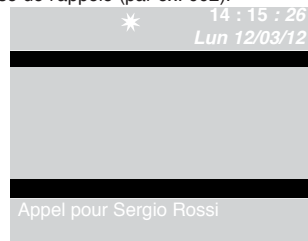

- ou adressé directement au standard (adresse=240)



- pour **répondre** à l'appel provenant de la platine extérieure, soulever le combiné ;



- le standard entre en communication avec la platine extérieure ;



- appuyer éventuellement sur la touche  pour valider la gâche électrique de la platine extérieure ; si l'ouvre-porte est effectué, une tonalité de confirmation retentira ;

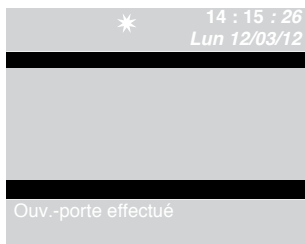

- **raccrocher** pour terminer la conversation.



- pour **refuser** l'appel, appuyer sur **CANC.**

ATTENTION !

En modalité NUIT (voir « I9 - Réglage modalité quotidienne » page 88), **les appels depuis la platine extérieure adressés à un poste intérieur s'affichent à l'écran mais ne peuvent pas être interceptés par le standard.**





U3 Comment appeler un poste intérieur

Pour appeler un poste intérieur, le standard peut utiliser 3 modalités différentes :

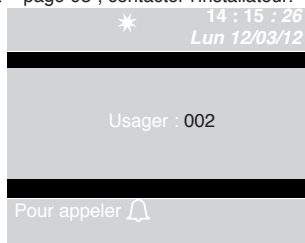
- taper le numéro du poste intérieur* et appuyer sur .

*Le numéro à taper dépend de la configuration du standard, voir « C4 - Appel via code Simplebus ou indirect » page 93 ; contacter l'installateur.



- appuyer sur  et dérouler le répertoire avec les touches   jusqu'à visualiser le nom désiré et appuyer sur .



- appuyer sur le **numéro bref** correspondant (ex. )
numéro bref 1= code mémorisé « 002 », voir « U22 Enregistrement numéros brefs » page 80).

- si l'appel a eu lieu correctement :

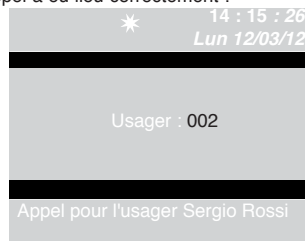

- si l'appel n'a pas eu lieu correctement :

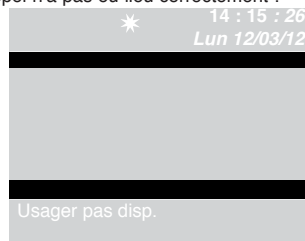

- si le poste intérieur est occupé :

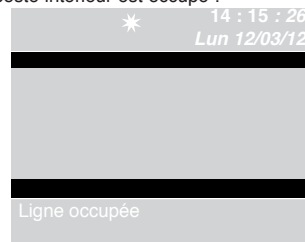

Lorsque le **poste intérieur appelé entre en phonie**, il entre en communication avec le standard, la durée maximum de la conversation correspond au temps de phonie programmé sur le standard principal (**MENU/Réglages/Temps/Phonie** - min. 10 secondes, max. 90 secondes).

U4 Comment passer un appel de la platine extérieure au poste intérieur

Lorsque le standard reçoit un appel d'une platine extérieure adressé à un poste intérieur :

- le NOM de l'appelé s'affiche (s'il existe au répertoire un nom associé au code appelé, voir « U17 Comment insérer un nom au répertoire » page 77).



- pour **répondre** à l'appel provenant de la platine extérieure, soulever le combiné dans les 60 secondes ;



- le standard entre en communication avec la platine extérieure, la durée maximum de la conversation est de 90 secondes ;



- appuyer sur la touche  pour mettre la platine extérieure en attente ;



Si le poste intérieur **n'accepte pas** la conversation, la platine extérieure reste en attente ; bloquer la conversation avec le poste intérieur et appuyer sur la touche  pour reprendre la communication avec la platine extérieure ;



- **raccrocher** pour terminer la conversation.



U5 Comment mettre en communication 2 postes intérieurs (fonction intercommunicante)

Lorsque le standard est en communication avec un poste intérieur (ex. 002) qui désire parler avec un autre poste intérieur (ex. 003) :

- mettre en attente le poste intérieur avec lequel on est en ligne (ex. 002), en appuyant sur la touche  ;

- appeler le poste intérieur désiré (ex. 003), voir « U3 Comment appeler un poste intérieur » page 69) ;

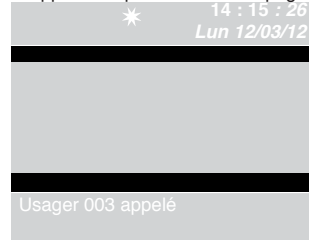

Lorsque le **poste intérieur appelé entre en phonie**, il se met en communication avec le standard ;

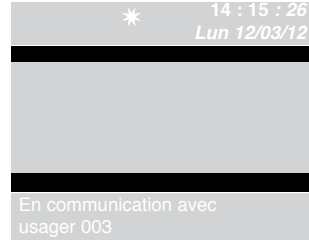

Pour lancer la conversation vers l'autre poste intérieur, appuyer sur la touche  ; le poste intérieur (003) entre en communication avec le poste intérieur (002) ; la durée maximale de la communication est de 2,5 minutes ;





- **raccrocher** le combiné.

Appuyer sur **CANC** pour remettre à zéro un appel intercommunicant actif depuis plus d'une minute.

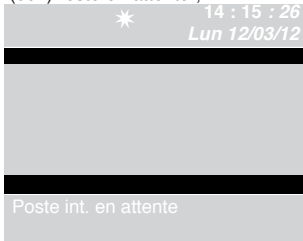

Si le poste intérieur **n'accepte pas** l'envoi de la conversation ou lorsque la **ligne est occupée** ou si **l'appel n'a pas eu lieu correctement**, le poste intérieur (002) reste en attente ;



- terminer la communication avec le poste intérieur (003) et appuyer sur la touche  pour reprendre la communication avec le poste intérieur (002) ;



- **raccrocher** pour terminer la conversation.



ATTENTION !

Si la platine extérieure appelle le standard durant un appel intercommunicant entre postes intérieurs en cours depuis plus d'une minute, ledit appel est automatiquement interrompu pour permettre au standard de gérer l'appel entrant.

U6 Comment appeler un poste intérieur présent dans les appels reçus

Lorsque le standard reçoit un appel du poste intérieur qui n'est pas géré dans les 30 sec. (opérateur momentanément absent ou occupé dans une autre conversation), ledit appel est automatiquement mémorisé dans le menu **Appels reçus**.

Le standard peut mémoriser un nombre maximum de 10 appels sans réponse. Le onzième appel se substitue au premier.

L'afficheur indique le nombre d'appels reçus (ex.  =3 clignotant).

Pour appeler les postes intérieurs présents dans les appels reçus, il faut :

- appuyer sur la touche **MENU** et appuyer sur les touches **▼▲** pour afficher le menu **Appels reçus** puis appuyer sur la touche **OK** ;

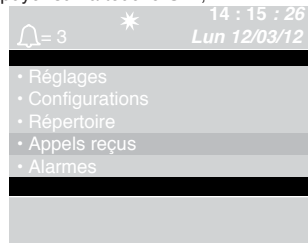

- appuyer sur les touches **▼▲** pour afficher la rubrique **Afficher** puis appuyer sur **OK** ;

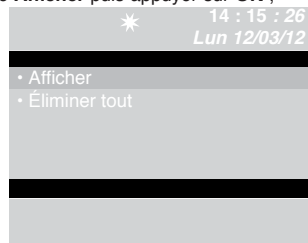

- les appels entrants s'afficheront dans l'ordre chronologique à partir du dernier reçu ; utiliser les touches **▼▲** pour dérouler la liste.



- appuyer sur la touche  pour appeler le poste intérieur qui s'affiche.

- appuyer sur la touche **MENU** pour afficher une fenêtre en bas à droite.

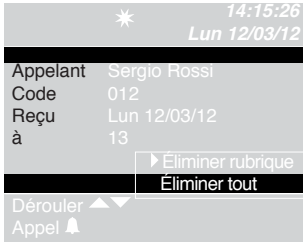

- appuyer sur la touche **OK** pour confirmer les réglages ;
 - appuyer plusieurs fois sur la touche **ESC** pour retourner à la page principale.

U7 Comment appeler un standard secondaire depuis le standard principal

Pour appeler un standard secondaire, le standard principal peut utiliser l'une des 3 modalités suivantes :

1 taper le numéro du standard (ex. 005 240) et appuyer sur :

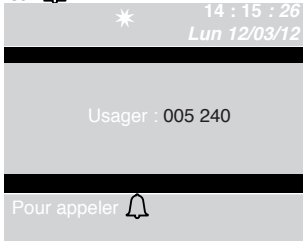

2 dérouler le répertoire avec les touches jusqu'à visualiser le nom et appuyer sur :

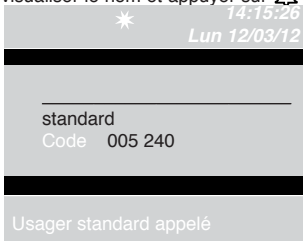

3 appuyer sur le **numéro bref** correspondant (voir « U22- Enregistrement numéros brefs » page 80).

- Si l'appel a eu lieu correctement :



- si l'appel n'a pas eu lieu correctement :

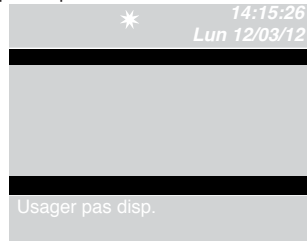

- si la ligne est occupée :

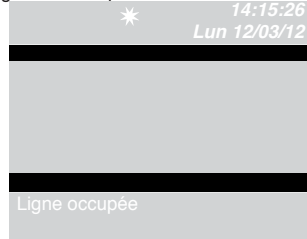

Lorsque le **standard appelé soulève le combiné**, il entre en communication avec le standard principal, la durée maximum de la conversation correspond au temps de phonie programmé sur le standard principal (**MENU/Réglages/Temps/Phonie** - min. 10 secondes, max. 90 secondes).

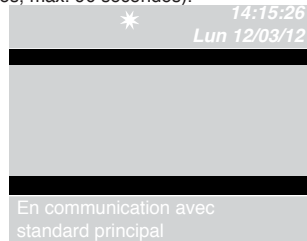

- **raccrocher** pour terminer la conversation.



ATTENTION !
 Le **standard secondaire** et le **standard principal** en communication entre eux ne peuvent ni envoyer les appels ni les mettre en attente.

U8 Comment appeler le standard principal depuis un standard secondaire

Pour appeler un standard principal depuis un standard secondaire, appuyer sur **#**.

Lorsque le **standard principal appelé soulève le combiné**, il entre en communication avec le standard secondaire, la durée maximum de la conversation correspond au temps de phonie programmé sur le standard principal (**MENU/Réglages/Temps/Phonie** - min. 10 secondes, max. 90 secondes).



- **raccrocher** pour terminer la conversation.



ATTENTION !

Le standard secondaire et le standard principal en communication entre eux ne peuvent ni envoyer les appels ni les mettre en attente.

U9 Comment répondre à un appel du standard secondaire au standard principal

Lorsque le standard principal reçoit un appel du standard secondaire :

- le NOM du standard secondaire d'où provient l'appel est visualisé, s'il a été saisi dans le répertoire (voir « U17 Comment insérer un nom au répertoire » page 77) ou l'adresse du standard appelant (ex. 005 240).



005 = indique la « zone »
240 = indique l'ID générique du standard

- pour **refuser** l'appel, appuyer sur **CANC.**
- pour **répondre** à l'appel provenant du standard secondaire, soulever le combiné ;



- le standard principal entre en communication avec le standard secondaire, la durée maximum de la conversation correspond au temps de phonie programmé sur le standard principal (**MENU/Réglages/Temps/Phonie** - min. 10 secondes, max. 90 secondes).



- **raccrocher** pour terminer la conversation.



ATTENTION !

Si le standard est occupé ou le/la standardiste est momentanément absent/e et ne peut pas répondre dans les 30 secondes, l'appel sera inséré dans la liste des **appels** (voir « U6 Comment appeler un poste intérieur présent dans les appels reçus » page 71).

U10 Comment répondre à un appel du standard principal au standard secondaire

Lorsque le standard secondaire reçoit un appel du standard principal :



- pour **répondre** à l'appel provenant du standard principal, soulever le combiné ;



- **raccrocher** pour terminer la conversation.



ATTENTION !

Si le standard est occupé ou le/la standardiste est momentanément absent/e et ne peut pas répondre dans les 30 secondes, l'appel sera inséré dans la liste des appels (voir « U6 Comment appeler un poste intérieur présent dans les appels reçus » page 71).

U11 Comment activer ou désactiver les standards principaux

En cas de 2 standards principaux en configuration série (voir page 116), procéder selon une des façons suivantes :

1 - appuyer sur la touche **MENU** du standard actif et appuyer sur les touches **▼▲** pour afficher le menu **Configurations** puis appuyer sur la touche **OK** ;

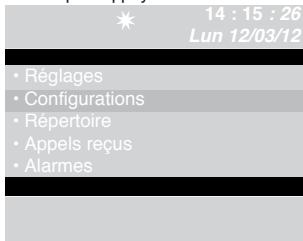

- appuyer sur les touches **▼▲** pour afficher le menu **Système** puis appuyer sur **OK** ;

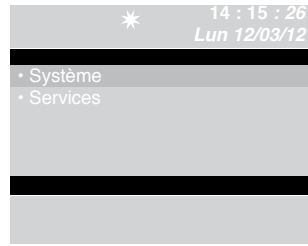

- appuyer sur les touches **▼▲** pour afficher le menu **Link** puis appuyer sur **OK** ;

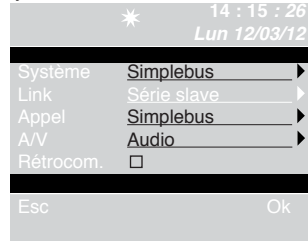

- sélectionner **Série slave** à l'aide des touches **◀▶** pour le désactiver.

Le standard s'éteint alors que l'autre standard s'allume en automatique et devient **Série master**.

- appuyer sur la touche **OK** pour confirmer les réglages ;
- appuyer plusieurs fois sur la touche **ESC** pour retourner à la page principale.

ou

1 - appuyer sur la touche **MENU** du standard inactif et appuyer sur les touches **▼▲** pour afficher le menu **Configurations** puis appuyer sur la touche **OK** ;

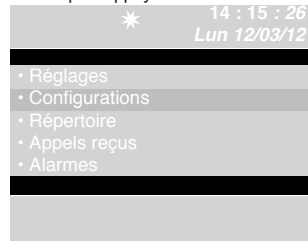

- appuyer sur les touches **▼▲** pour afficher le menu **Système** puis appuyer sur **OK** ;

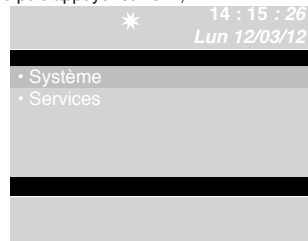

- appuyer sur les touches ▼▲ pour afficher le menu **Link** puis appuyer sur **OK** ;

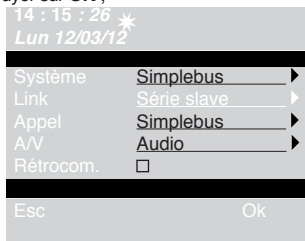

- sélectionner **Série master** à l'aide des touches ◀▶ pour confirmer que le standard doit être validé.

L'autre standard se désactive en automatique et devient **Série slave**.

- appuyer sur la touche **OK** pour confirmer les réglages ;
- appuyer plusieurs fois sur la touche **ESC** pour retourner à la page principale.

U12 Comment utiliser l'ouvre-porte

Possibilité de commander la gâche électrique à partir de la platine extérieure en appuyant sur la touche ⤹ ; si la commande est obtenue, une tonalité de confirmation retentira.

U13 Comment activer la fonction « Suivi » (FollowMe)

Cette fonction permet de dévier les appels destinés au standard vers les appareils téléphoniques locaux ou à distance.

ATTENTION !

Pour utiliser cette fonction, la centrale Art. 2906 avec interface Art. 2912 doit être présente. S'adresser à l'installateur de confiance.

Cette fonction n'est activable que sur le standard programmé comme secondaire (voir « C1 Type de standard » page 91).

Pour valider cette fonction :

- appuyer sur la touche **MENU** et sur les touches ▼▲ pour afficher le menu **Configurations** puis appuyer sur la touche **OK** ;

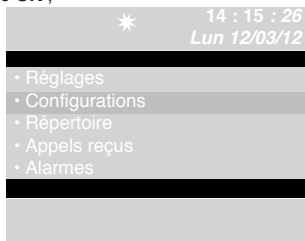

- appuyer sur les touches ▼▲ pour afficher le menu **Services** puis appuyer sur **OK** ;

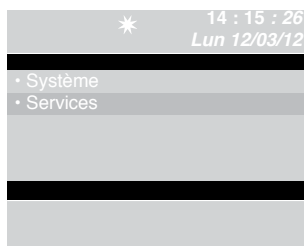

- afficher le service **FollowMe** à l'aide des touches ▼▲. Valider le service à l'aide de la touche ▶. Désactiver en appuyant sur ◀.

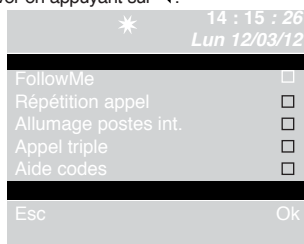

- appuyer sur la touche **OK** pour confirmer les réglages ;
- appuyer plusieurs fois sur la touche **ESC** pour retourner à la page principale.

À la suite d'un appel, le standard sonnera de toute manière et tant que l'appareil à distance n'entrera pas en communication, il sera possible de répondre à l'appel depuis le standard en annulant la fonction « Suivi ».

U14 Comment activer un relais supplémentaire (par ex. pour activer en mode indépendant et avec une commande dédiée : éclairage, contacts d'alarme TVCC, grilles de sortie de garage, entrées sans platine extérieure ou autres dispositifs)

Les actionneurs peuvent être activés tant en modalité de repos qu'en modalité de conversation vers la platine extérieure.

ATTENTION !

Pour utiliser cette fonction, il est nécessaire d'avoir une platine extérieure principale et des actionneurs Art. 1256. S'adresser à l'installateur de confiance.

Pour activer l'actionneur :

- appuyer sur la touche * (code), saisir le code pour activer un actionneur spécifique ; en cas de code manquant, un actionneur générique sera activé ;

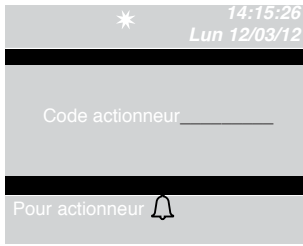

- pour confirmer l'activation de l'actionneur, appuyer sur la touche .

- appuyer sur les touches pour afficher la rubrique **Afficher** puis appuyer sur **OK** ;

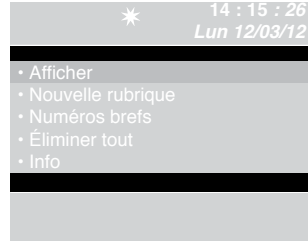

- les noms mémorisés dans le répertoire s'afficheront dans l'ordre alphabétique ; utiliser les touches pour dérouler la liste.

Pour accélérer le déroulement de la liste de noms, appuyer sur la touche ou sur la touche .



Ou

- saisir le nom également avec une partie de l'extension ; S'il existe plusieurs usagers avec l'initiale saisie, il est possible de dérouler la liste à l'aide des touches .

- appuyer sur la touche **MENU** pour afficher une fenêtre en bas à droite.

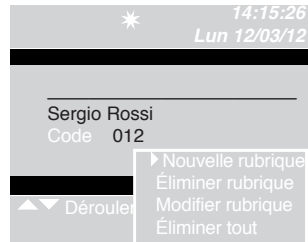

Possibilité d'ajouter une nouvelle rubrique, d'éliminer la rubrique sélectionnée, de la modifier ou d'effacer tout le répertoire.

Sélectionner l'opération désirée à l'aide des touches puis appuyer sur la touche **OK**.

- appuyer plusieurs fois sur la touche **ESC** pour retourner à la page principale.

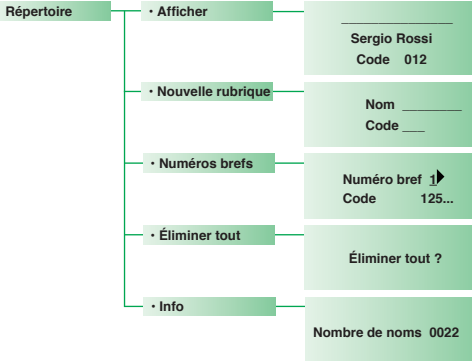

U15 Comment utiliser le répertoire

Possibilité de saisir jusqu'à 4000 noms ayant au maximum 13 caractères alphanumériques, en associant à chaque nom un code qui correspond à celui du poste intérieur désiré.

U16 Comment chercher un nom en répertoire

Pour afficher le répertoire, appuyer sur la touche et dérouler la liste des usagers à l'aide des touches ; pour accélérer l'opération, garder le doigt sur la touche. Le NOM et le CODE associé à chaque usager sont affichés.

Ou

- appuyer sur la touche **MENU** et appuyer sur les touches pour afficher le menu **Répertoire** puis appuyer sur la touche **OK** ;

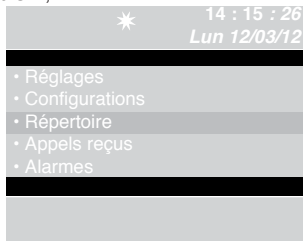

U17 Comment insérer un nom au répertoire

Si l'on désire insérer un nom en répertoire :

- appuyer sur la touche **MENU** et appuyer sur les touches ▼▲ pour afficher le menu **Répertoire** puis appuyer sur la touche **OK** ;

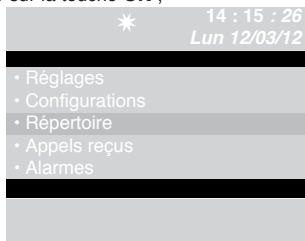

- appuyer sur les touches ▼▲ pour afficher la rubrique **Nouvelle rubrique** puis appuyer sur **OK** ;

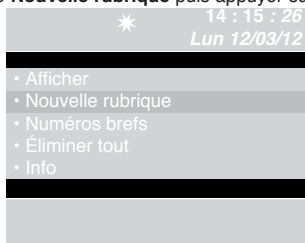

- saisir le nouveau nom à l'aide du clavier alphanumérique ; appuyer sur la touche ▼ et saisir le code à l'aide du clavier.

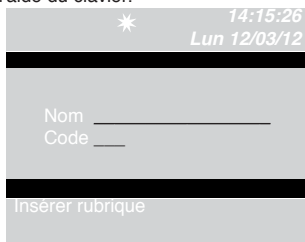

- appuyer sur la touche **OK** pour confirmer les réglages ;

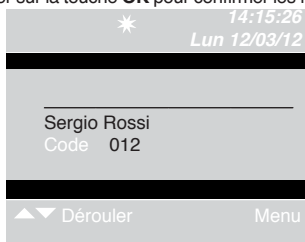

- appuyer sur la touche **MENU** pour afficher une fenêtre en bas à droite.

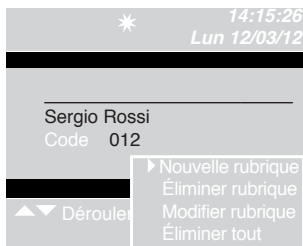

Possibilité d'ajouter une nouvelle rubrique, d'éliminer la rubrique sélectionnée, de la modifier ou d'effacer tout le répertoire.

Sélectionner l'opération désirée à l'aide des touches ▼▲ puis appuyer sur la touche **OK**.

- appuyer plusieurs fois sur la touche **ESC** pour retourner à la page principale.

U18 Comment effacer un nom du répertoire

ATTENTION !

Pour effacer le répertoire complet, voir « U20 - Effacer répertoire » page 79.

Si l'on veut effacer un nom en répertoire :

- appuyer sur la touche **MENU** et appuyer sur les touches ▼▲ pour afficher le menu **Répertoire** puis appuyer sur la touche **OK** ;

- appuyer sur les touches ▼▲ pour afficher la rubrique **Afficher** puis appuyer sur **OK** ;

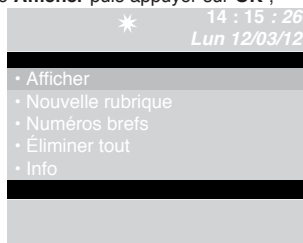

- les noms mémorisés dans le répertoire s'afficheront dans l'ordre alphabétique ; utiliser les touches ▼▲ pour dérouler la liste.

Pour accélérer le déroulement de la liste de noms, appuyer sur la touche ▼ ou sur la touche ▲.



Ou

- saisir le nom également avec une partie de l'extension ;
- S'il existe plusieurs usagers avec l'initiale saisie, il est possible de dérouler la liste à l'aide des touches ▼.



- appuyer sur la touche **MENU** pour afficher une fenêtre en bas à droite.

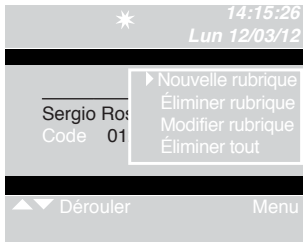

- appuyer sur la touche ▼ pour afficher la rubrique **Éliminer rubrique** puis appuyer sur **OK** ;

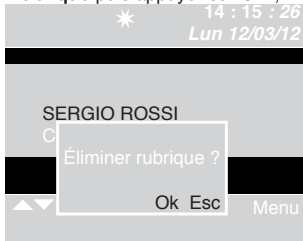

- pour confirmer l'effacement, appuyer sur la touche **OK** ;
- appuyer plusieurs fois sur la touche **ESC** pour retourner à la page principale.

U19 Comment modifier un nom en répertoire

Si l'on désire modifier un nom en répertoire :

- appuyer sur la touche **MENU** et appuyer sur les touches ▼▲ pour afficher le menu **Répertoire** puis appuyer sur la touche **OK** ;

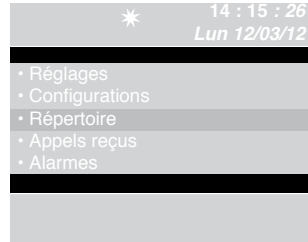

- appuyer sur les touches ▼▲ pour afficher la rubrique **Afficher** puis appuyer sur **OK** ;

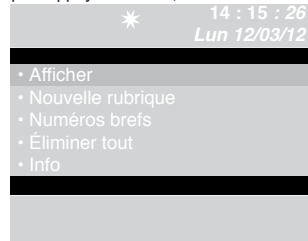

- les noms mémorisés dans le répertoire s'afficheront dans l'ordre alphabétique ; utiliser les touches ▼▲ pour dérouler la liste.

Pour accélérer le déroulement de la liste de noms, appuyer sur la touche ▼ ou sur la touche ▲.

Ou

- saisir le nom également avec une partie de l'extension ;
- S'il existe plusieurs usagers avec l'initiale saisie, il est possible de dérouler la liste à l'aide des touches ▼▲.

- appuyer sur la touche **MENU** pour afficher une fenêtre en bas à droite.

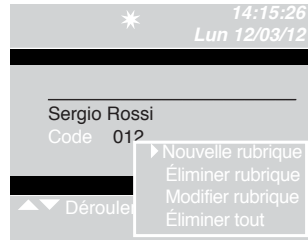

- appuyer sur la touche ▼ pour afficher la rubrique **Modifier rubrique** puis appuyer sur **OK** ;

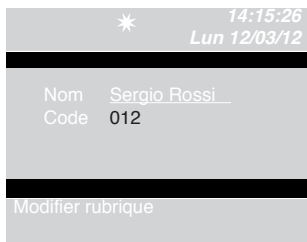

- appuyer sur les touches ▼▲ pour afficher la rubrique à modifier (nom ou code).

- appuyer sur **CANC** pour effacer la rubrique sélectionnée et saisir le nouveau nom ou code au clavier alphanumérique ;

- pour confirmer la modification du nom, appuyer sur **OK** puis appuyer sur **ESC** pour sortir.

U20 Effacer le répertoire

- appuyer sur la touche **MENU** et appuyer sur les touches ▼▲ pour afficher le menu **Répertoire** puis appuyer sur la touche **OK** ;

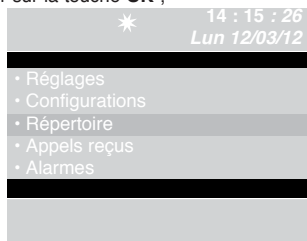

- appuyer sur les touches ▼▲ pour afficher la rubrique **Éliminer tout** puis appuyer sur **OK** ;

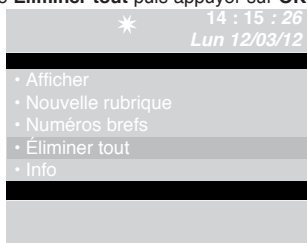

- une page demandant de confirmer l'élimination de tout le répertoire s'affiche ; confirmer en appuyant sur **OK** ou annuler en appuyant sur **ESC** ;

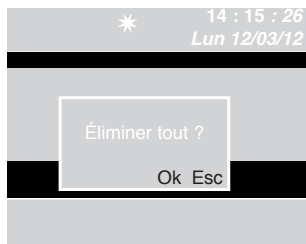

- appuyer plusieurs fois sur la touche **ESC** pour retourner à la page principale.

U21 Info répertoire

- appuyer sur la touche **MENU** et appuyer sur les touches ▼▲ pour afficher le menu **Répertoire** puis appuyer sur la touche **OK** ;

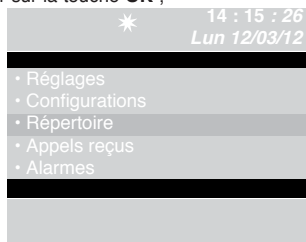

- appuyer sur les touches ▼▲ pour afficher la rubrique **Info** puis appuyer sur **OK** ;

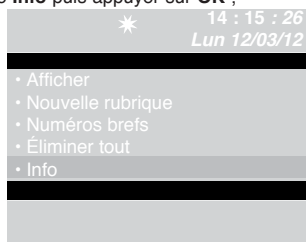

- une page indiquant le nombre de noms mémorisés dans le répertoire s'affiche ;

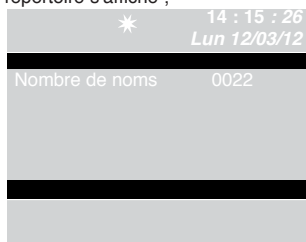

- appuyer plusieurs fois sur la touche **ESC** pour retourner à la page principale.

- appuyer sur la touche **MENU** pour afficher une fenêtre en bas à droite.

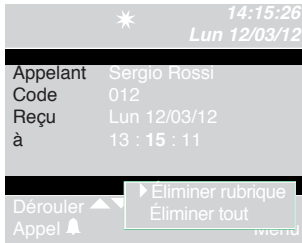

- appuyer sur la touche **OK** pour confirmer les réglages ;
- appuyer plusieurs fois sur la touche **ESC** pour retourner à la page principale.

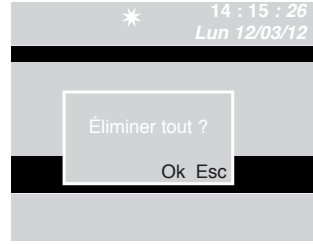

- appuyer plusieurs fois sur la touche **ESC** pour retourner à la page principale.

U24 - Effacement liste des appels reçus

- appuyer sur la touche **MENU** et sur les touches ▼ ▲ pour afficher le menu **Appels reçus** puis appuyer sur la touche **OK** ;

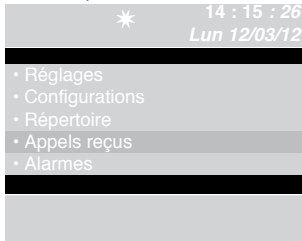

- appuyer sur les touches ▼ ▲ pour afficher la rubrique **Éliminer tout** puis appuyer sur **OK** ;

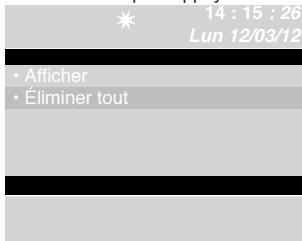

- une page demandant de confirmer l'élimination de la liste des appels reçus s'affiche ; confirmer en appuyant sur **OK** ou annuler en appuyant sur **ESC** ;

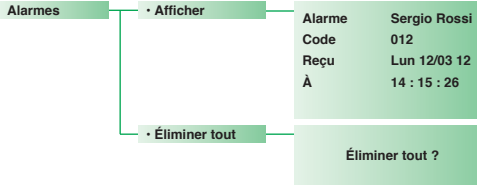

U25 - Affichage des alarmes

- Pour accéder rapidement à l'affichage des alarmes, appuyer sur la touche **MENU** + touche **1** ou appuyer sur la touche **MENU** et sur les touches **▼▲** pour afficher le menu **Alarmes** puis appuyer sur **OK** ;

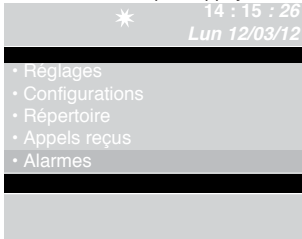

- appuyer sur les touches **▼▲** pour afficher la rubrique **Afficher** puis appuyer sur **OK** ;

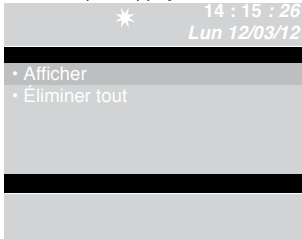

- les alarmes s'afficheront dans l'ordre chronologique à partir de la dernière ; utiliser les touches **▼▲** pour dérouler la liste.

Pour accélérer le déroulement de la liste de noms, appuyer sur la touche **▼** ou sur la touche **▲**.



- appuyer sur la touche **MENU** pour afficher une fenêtre en bas à droite.



- appuyer plusieurs fois sur la touche **ESC** pour retourner à la page principale.

U26 - Effacement liste alarmes reçues

- appuyer sur la touche **MENU** puis sur les touches **▼▲** pour afficher le menu **Alarmes** puis appuyer sur la touche **OK** ;

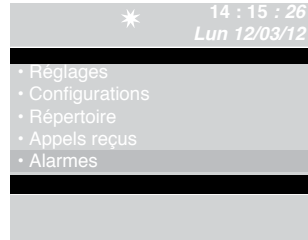

- appuyer sur les touches **▼▲** pour afficher la rubrique **Éliminer tout** puis appuyer sur **OK** ;

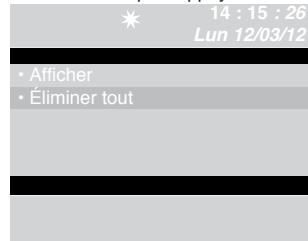

- une page demandant de confirmer l'élimination de la liste des alarmes s'affiche ; confirmer en appuyant sur **OK** ou annuler en appuyant sur **ESC** ;

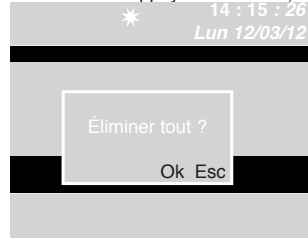

- appuyer plusieurs fois sur la touche **ESC** pour retourner à la page principale.

RÉGLAGES

Paramétrage

Langue

- ▶ Italiano
- English
- Français
- Deutsch
- Español
- Portugais
- Hollandais
- Danois
- Norvégien
- Finlandais
- Suédois
- Turc
- Russe
- Polonais
- Croate

• Vidéo

- Luminosité 
- Contraste 
- Couleur 

• Audio

- Intérieur
- Extérieur

Micro 

Haut-parleur 

• Sons

- Extérieur ▶ Le printemps
- Intérieur ▶ Le printemps
- Alarme ▶ Alarme 1
- Tonalité touches
-

• Date

- Année ◀ 2010 ▶
- Mois ▶ Mars
- Jour ▶ 12

• Heure

- Heures ▶ 14
- Minutes ▶ 15
- Secondes ▶ 26

• Thèmes

- Thèmes ▶ Thème blue
- ◀ Thème Planux ▶
- ◀ Thème Green ▶
- ◀ Thème Red ▶
- ◀ Thème Yellow ▶
- ◀ Thème Pink ▶
- ◀ Thème Orange ▶

• Temps

- Phonie ▶ 010
- Attente reset ▶ 01
- Veille ▶ 010
- Activation relais ▶ 01
- Répétition appel ▶ 01

• Mod. quotidienne

- Valider
- Dim ▶ Nuit
- Lun ▶ Nuit
- Mar ▶ Nuit
- Mer ▶ Nuit
- Jeu ▶ Nuit
- Ven ▶ Nuit
- Sam ▶ Nuit

• Commut. automatique

- Cmt 1 00 ▶ : 00 ▶ ▶ Jour
- Cmt 2 00 ▶ : 00 ▶ ▶ Nuit
- Cmt 3 00 ▶ : 00 ▶ ▶ Jour
- Cmt 4 00 ▶ : 00 ▶ ▶

• Reset paramétrage

Réinitialiser ?

I1 - Modifier langue

Il est possible de programmer la langue en la sélectionnant parmi les suivantes :

► Italiano (défaut)

English
 Français
 Deutsch
 Español
 Portugais
 Hollandais
 Danois
 Norvégien
 Finlandais
 Suédois
 Turc
 Russe
 Polonais
 Croate

- appuyer sur la touche **MENU** puis sur les touches ▼▲ pour afficher le menu **Réglages** puis appuyer sur la touche **OK** ;

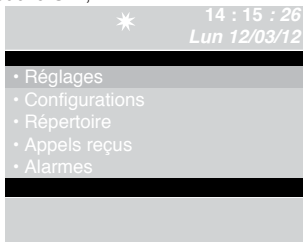

- appuyer sur les touches ▼▲ pour afficher le menu **Langue** puis appuyer sur **OK** ;



- appuyer sur les touches ▼▲ pour afficher la langue choisie puis appuyer sur **OK** pour confirmer ;
 - appuyer plusieurs fois sur la touche **ESC** pour retourner à la page principale.



I2 - Réglages vidéo

Cette fonction permet de régler la luminosité, le contraste et la couleur du moniteur du standard.

- Pour accéder rapidement aux réglages vidéo, appuyer sur la touche **MENU** + touche **3** ou appuyer sur la touche **MENU** puis sur les touches ▼▲ pour afficher le menu **Réglages** puis appuyer sur **OK** ;

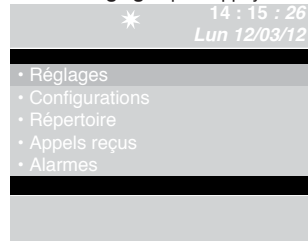

- appuyer sur les touches ▼▲ pour afficher le menu **Vidéo** puis appuyer sur **OK** ;



- utiliser les touches ▼▲ pour afficher les valeurs vidéo à régler (luminosité, contraste, couleur) et les diminuer ou les augmenter à l'aide des touches ◀ ▶ ;

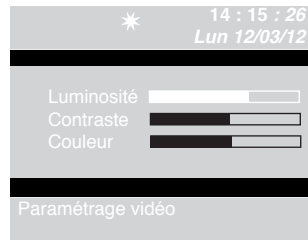

- appuyer sur la touche **OK** pour confirmer les réglages ;
 - appuyer plusieurs fois sur la touche **ESC** pour retourner à la page principale.

I3 - Réglages audio

Cette fonction permet de régler le volume du micro et du haut-parleur du standard vers les postes intérieurs et vers la platine extérieure.

Pour modifier les volumes, le standard doit être en communication avec un poste intérieur ou une plaque de rue.

- Pour accéder rapidement aux réglages audio, appuyer sur la touche **MENU** + touche **4 (extérieur)** touche **5 (intérieur)** ou appuyer sur la touche **MENU** puis sur les touches **▼▲** pour afficher le menu **Réglages** puis appuyer sur **OK** ;

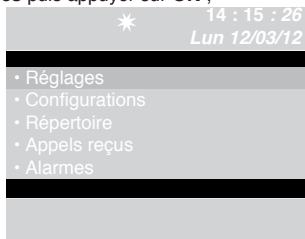

- appuyer sur les touches **▼▲** pour afficher le menu **Audio** puis appuyer sur **OK** ;



- utiliser les touches **▼▲** pour afficher les valeurs audio à régler (intérieur et/ou extérieur) puis appuyer sur **OK** ;



- utiliser les touches **▼▲** pour afficher les valeurs audio à régler (micro et/ou haut-parleur) et les diminuer ou les augmenter à l'aide des touches **◀▶** ;

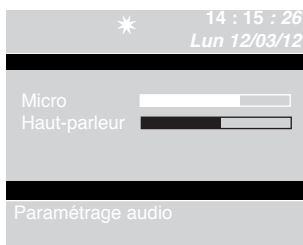

- appuyer sur la touche **OK** pour confirmer les réglages ;
- appuyer plusieurs fois sur la touche **ESC** pour retourner à la page principale.

I4 - Réglages sons

Cette fonction permet de configurer la mélodie des appels entrants des postes intérieurs, de la platine extérieure et des appels d'alarme ; elle permet également de valider ou de désactiver la tonalité des touches.

- appuyer sur la touche **MENU** puis sur les touches **▼▲** pour afficher le menu **Réglages** puis appuyer sur la touche **OK** ;

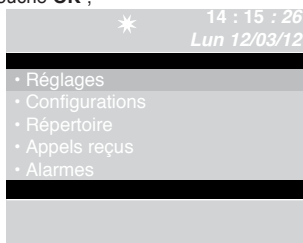

- appuyer sur les touches **▼▲** pour afficher le menu **Sons** puis appuyer sur **OK** ;



- utiliser les touches **▼▲** pour afficher les valeurs sons à régler (extérieur, intérieur, alarme ou tonalité touches) ;

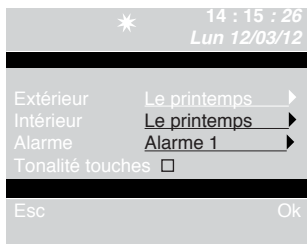

- sélectionner la mélodie à l'aide des touches ◀▶. Valider le service Tonalité à l'aide de la touche ▶. Désactiver en appuyant sur ◀.

- appuyer sur la touche **OK** pour confirmer les réglages ;
- appuyer plusieurs fois sur la touche **ESC** pour retourner à la page principale.

I5 - Modifier date

- appuyer sur la touche **MENU** puis sur les touches ▼▲ pour afficher le menu **Réglages** puis appuyer sur la touche **OK** ;

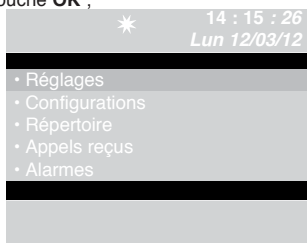

- appuyer sur les touches ▼▲ pour afficher le menu **Date** puis appuyer sur **OK** ;



- utiliser les touches ▼▲ pour afficher les valeurs à régler (année, mois, jours) et les modifier à l'aide des touches ◀▶ ;

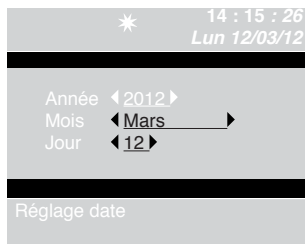

- appuyer sur la touche **OK** pour confirmer les réglages ;
- appuyer plusieurs fois sur la touche **ESC** pour retourner à la page principale.

I6 - Modifier heure

- appuyer sur la touche **MENU** puis sur les touches ▼▲ pour afficher le menu **Réglages** puis appuyer sur la touche **OK** ;

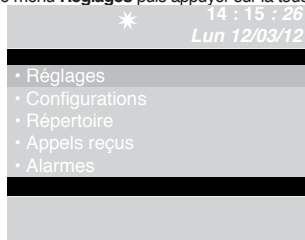

- appuyer sur les touches ▼▲ pour afficher le menu **Heure** puis appuyer sur **OK** ;

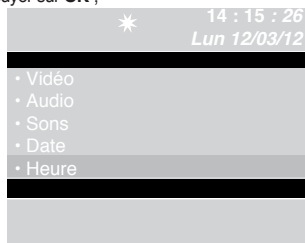

- utiliser les touches ▼▲ pour afficher les valeurs à régler (heures, minutes, secondes) et les diminuer ou les augmenter à l'aide des touches ◀▶ ;

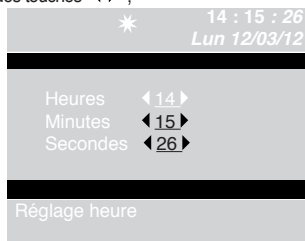

- appuyer sur la touche **OK** pour confirmer les réglages ;
- appuyer plusieurs fois sur la touche **ESC** pour retourner à la page principale.

I7 - Réglage thème

Cette fonction permet de modifier les couleurs des pages des menus.

- appuyer sur la touche **MENU** puis sur les touches ▼▲ pour afficher le menu **Réglages** puis appuyer sur la touche **OK** ;



- appuyer sur les touches ▼▲ pour afficher le menu **Thèmes** puis appuyer sur **OK** ;

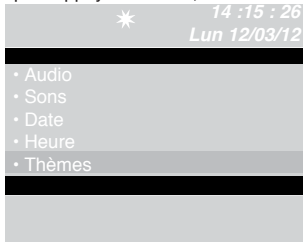

- sélectionner le thème choisi avec les touches ◀▶ ;

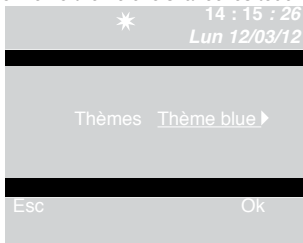

- appuyer sur la touche **OK** pour confirmer les réglages;

- appuyer plusieurs fois sur la touche **ESC** pour retourner à la page principale.

I8 - Réglage temps

Cette fonction permet de régler les temps de phonie, attente reset, veille, activation relais et répétition d'appel.

- appuyer sur la touche **MENU** puis sur les touches ▼▲ pour afficher le menu **Réglages** puis appuyer sur la touche **OK** ;



- appuyer sur les touches ▼▲ pour afficher le menu **Temps** puis appuyer sur **OK** ;

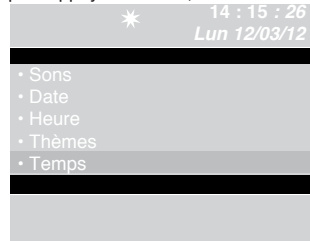

- utiliser les touches ▼▲ pour afficher le menu de réglage (phonie, attente reset, veille, activation relais, répétition d'appel) et les diminuer ou les augmenter à l'aide des touches ◀▶.

Pour dérouler plus rapidement les valeurs, appuyer sur la touche ◀ ou sur la touche ▶.

Valeurs de phonie : 10"-180" max

Valeurs d'attente reset : 1"-10" max

Valeurs de veille : 10"-120" max

Valeurs d'activation relais : 1"20" max

Valeurs de répétition d'appel : 1"30" max

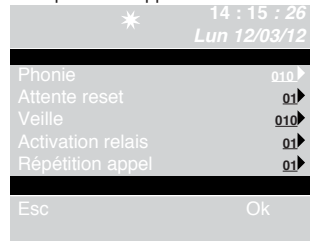

- appuyer sur la touche **OK** pour confirmer les réglages ;

- appuyer plusieurs fois sur la touche **ESC** pour retourner à la page principale.

I9 - Réglage modalité quotidienne

On peut décider d'organiser la semaine en choisissant, pour chaque jour, l'une des 3 modalités suivantes de fonctionnement :

- **AUTO** : le système passe de la modalité JOUR à la modalité NUIT aux heures programmées.
- **NUIT** : le système reste dans cette modalité toute la journée.
- **JOUR** : le système reste dans cette modalité toute la journée. Si le choix porte sur « auto », la modalité de fonctionnement commutera aux horaires fixés dans le cadre de la journée, en fonction de la programmation effectuée selon le paragraphe « I10 - Réglage commut. automatique » page 88.





Pour désactiver la fonction, appuyer sur la touche .
Pour la valider :

- appuyer sur la touche **MENU** puis sur les touches  pour afficher le menu **Réglages** puis appuyer sur la touche **OK** ;

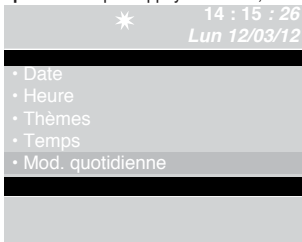



- appuyer sur les touches  pour afficher le menu **Modalité quotidienne** puis appuyer sur **OK** ;

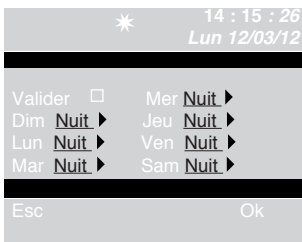

- utiliser les touches  pour afficher le jour à configurer et sélectionner la modalité nuit, jour ou auto à l'aide des touches .



- après avoir terminé la programmation de chaque jour de la semaine, se placer sur la rubrique **Valider** et valider toute la

- programmation en appuyant sur , pour désactiver, appuyer sur  ;
- appuyer sur la touche **OK** pour confirmer les réglages ;
- appuyer plusieurs fois sur la touche **ESC** pour retourner à la page principale.

I10 - Réglage commut. automatique

Possibilité de programmer le passage automatique de la modalité JOUR à la modalité NUIT à des horaires déterminés programmables par l'utilisateur. Il est possible de programmer jusqu'à 4 HORAIRES par jour pour lesquels il faudra régler le mode de commutation (Jour ou Nuit).

Exemple :

Pour programmer le standard avec ces paramètres :
07:00 -12:00 Fonctionnement Jour
13:00 - 22:00 Fonctionnement Jour

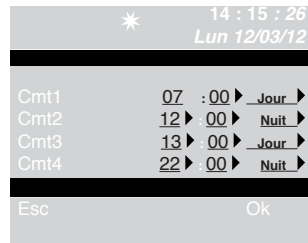

- appuyer sur la touche **MENU** puis sur les touches  pour afficher le menu **Réglages** puis appuyer sur la touche **OK** ;

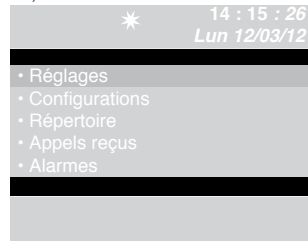

- appuyer sur les touches  pour afficher le menu **Comm. automatique** puis appuyer sur **OK** ;

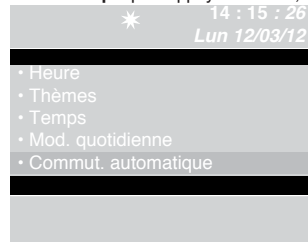

- le curseur se met automatiquement sur l'heure min. de la commut. 1 ; diminuer ou augmenter la valeur à l'aide

des touches ◀ ▶.

La valeur peut varier de 00 à 23.

Pour dérouler plus rapidement les valeurs, appuyer sur la touche ◀ ou sur la touche ▶.

- se mettre sur la valeur en minutes de la commut. 1 à l'aide de la touche ▼, diminuer ou augmenter la valeur à l'aide des touches ◀ ▶.

La valeur peut varier de 00 à 59.

Pour dérouler plus rapidement les valeurs, appuyer sur la touche ◀ ou sur la touche ▶.

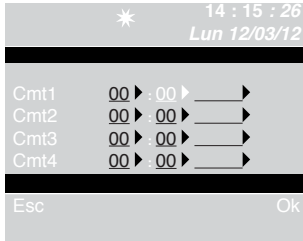

- se mettre sur la dernière rubrique de la commut. 1 à l'aide de la touche ▼, sélectionner la modalité (jour, nuit) à l'aide des touches ◀ ▶.

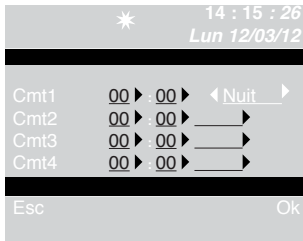

- suivre cette procédure pour toutes les commutations nécessaires ;

- appuyer sur la touche **OK** pour confirmer les réglages ;

- appuyer plusieurs fois sur la touche **ESC** pour retourner à la page principale.

I11 - Reset des réglages

- appuyer sur la touche **MENU** puis sur les touches ▼ ▲ pour afficher le menu **Réglages** puis appuyer sur la touche **OK** ;

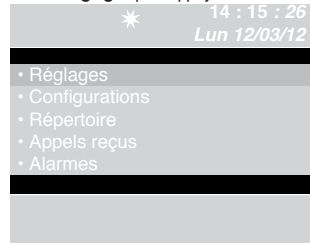

- appuyer sur les touches ▼ ▲ pour afficher le menu **Reset réglages** puis appuyer sur **OK** ;

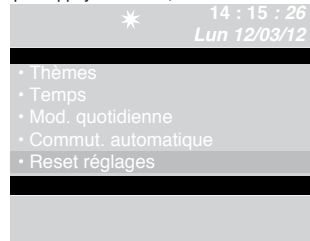

- une page demandant de confirmer le reset des réglages s'affiche ; confirmer en appuyant sur **OK** ou annuler en appuyant sur **ESC** ;

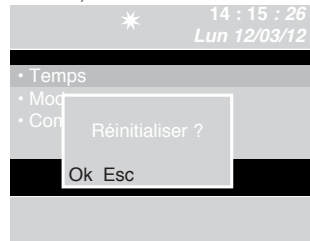

- en appuyant sur **OK**, la page de redémarrage du système s'affiche ;

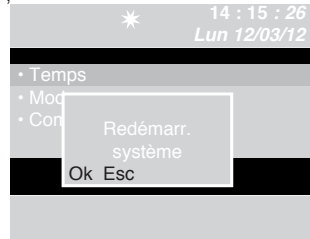

- confirmer le redémarrage du système en appuyant sur **OK** ou annuler en appuyant sur **ESC** ;

- appuyer plusieurs fois sur la touche **ESC** pour retourner à la page principale.

CONFIGURATIONS INSTALLATEUR

Configurations

• Système

Système	Simplebus	▶	◀	Simplebus Top	_____
Link	Simple	▶	◀	Parall. LS-IN	▶
				◀	Parall. LP-IN
	◀	Série master	▶	◀	Série slave
Appel		Simplebus	▶	◀	Indirect
A/V		Audio	▶	◀	Vidéo
Rétrocom.					<input type="checkbox"/>

• Services

FollowMe	<input type="checkbox"/>
Répétition appel	<input type="checkbox"/>
Allumage postes intérieurs	<input type="checkbox"/>
Appel triple	<input type="checkbox"/>
Aide codes	<input type="checkbox"/>

CONFIGURATIONS INSTALLATEUR

Ce chapitre s'adresse au personnel qualifié qui, après l'installation, procédera à la programmation du standard de conciergerie au moyen de menus guidés et affichés sur l'écran, disponibles à partir du menu principal.

C1 - Type de standard (mode Simplebus Top)

Le standard peut être secondaire ou principal.

- Configurer **Simplebus** lorsque le standard est utilisé comme secondaire, à la sortie des bornes LM-LM des commutateurs Art. 1424 (installation Simplebus TOP) (voir schéma SBTOP/001DSMC page 110) ; ou lorsque le standard est utilisé sur des installations Simplebus avec les commutateurs Art. 1224A ou sur une installation avec montant simple sans commutateur.

ATTENTION ! le standard SECONDAIRE ne peut pas être configuré comme standard en parallèle.

- Configurer **Simplebus top** lorsque le standard est utilisé comme principal sur une installation Simplebus top, positionné sur le tronçon en amont des commutateurs Art. 1424 qui définissent les zones/montants (voir schéma SBTOP/002DSMC page 112).

Le standard secondaire ou principal doit être ensuite configuré comme :

- 1- SIMPLE
- 2- PARALLÈLE
- 3- SÉRIE.

- 1- Sélectionner **simple** lorsque le standard est le seul présent dans l'installation ou bien le seul desservant un montant déterminé.

- 2- En présence de 2 standards principaux ou secondaires desservant le même montant, la configuration **parallèle** implique que les deux standards auront les mêmes fonctions (voir schéma SBTOP/005DSMC page 118).

Le premier des deux qui répond à un appel empêche l'autre d'effectuer la même opération. L'allumage ou l'extinction de l'un des 2 provoquera automatiquement l'allumage ou l'extinction de l'autre.

Configurer comme **Parall. LS-IN** le standard relié sous la ligne LS-LS du commutateur Art. 1424 ; configurer comme **Parall. LP-IN** celui qui est sous la ligne LPin-LPin du commutateur Art. 1424.

Pour le standard parallèle, la commutation en NUIT et la fonction JOUR/NUIT AUTOMATIQUE ne sont pas possibles (voir « I9- Réglage modalité quotidienne » page 88).

Dans la page de repos des deux standards, on devra avoir **P**, qui indique le standard configuré en parallèle et l'icône fixe ➔.

- 3- En présence de 2 standards principaux ou secondaires desservant le même montant, la configuration **série** implique que seulement 1 des 2 peut être opérationnel (**Série master**), alors que l'autre est désactivé (**Série slave**) (voir schéma SBTOP/004DSMC page 116). Pour commuter un standard de MASTER à SLAVE et vice versa, voir « U11 Comment activer ou désactiver les standards principaux » page 74.

Dans la page de repos des deux standards, il devra y avoir **S**, qui indique le standard configuré en série et l'icône fixe ➔.

ATTENTION !

- si ➔ clignote, cela indique que les 2 standards ne communiquent pas correctement.

- si l'icône ! s'affiche, il y a un problème de configuration des 2 standards (par ex, les deux Séries master ou slave, Parall. LP-IN ou Parall. LS-IN ou un série et l'autre parallèle).

- si une installation Simplebus TOP (avec commutateurs Art. 1424) disposent de standards principaux et secondaires (voir schéma SBTOP/003DSMC page 114) ; configurer « C5- Rétrocompatibilité » page 93 pour assurer le fonctionnement correct de l'installation.

C2 - Comment configurer un standard principal ou secondaire

- appuyer sur la touche **MENU** et sur les touches ▼ ▲ pour afficher le menu **Configurations** puis appuyer sur la touche **OK** ;

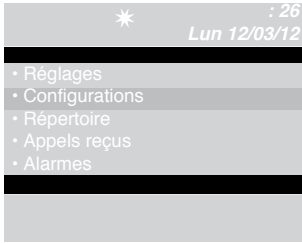

- appuyer sur les touches ▼ ▲ pour afficher le menu **Système** puis appuyer sur **OK** ;

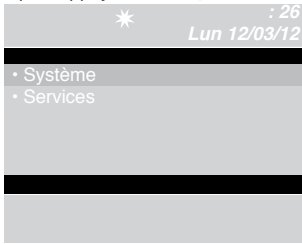

- appuyer sur les touches ▼ ▲ pour afficher le menu **Système** puis appuyer sur **OK** ;

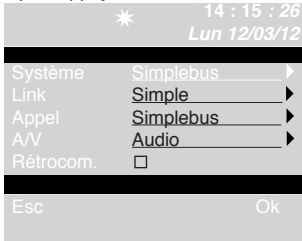

- sélectionner Simplebus (pour standard secondaire) ou Simplebus Top (pour standard principal) à l'aide des touches ◀ ▶ .
 - appuyer sur la touche **OK** pour confirmer les réglages ;
 - appuyer plusieurs fois sur la touche **ESC** pour retourner à la page principale.

C3 - Comment configurer un standard simple, en parallèle ou en série

- appuyer sur la touche **MENU** et sur les touches ▼ ▲ pour afficher le menu **Configurations** puis appuyer sur la touche **OK** ;

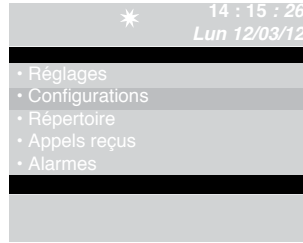

- appuyer sur les touches ▼ ▲ pour afficher le menu **Système** puis appuyer sur **OK** ;

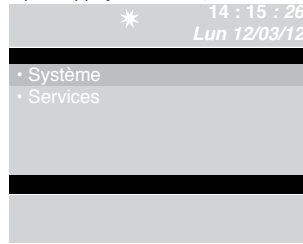

- appuyer sur les touches ▼ ▲ pour afficher le menu **Link** puis appuyer sur **OK** ;

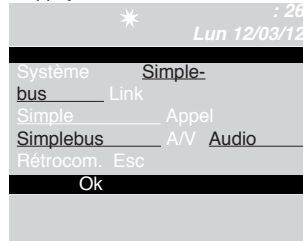

- sélectionner **Simple, Parall. LS-IN, Parall. LP-IN, Série master, Série slave** à l'aide des touches ◀ ▶ .
 - appuyer sur la touche **OK** pour confirmer les réglages ;
 - appuyer plusieurs fois sur la touche **ESC** pour retourner à la page principale.

C4 - Appel via code Simplebus ou indirect

Cette fonction permet de choisir la modalité manuelle d'appel du standard, entre 2 modalités différentes :

1- Appel Simplebus (par défaut), l'appel a lieu en saisissant le code associé à chaque usager.

- Si le type d'installation est **Simplebus**, l'usager est identifié par un champ **Nom Usager** (optionnel) et par un champ **Code** à 3 chiffres maximum (compris entre 1 et 240).

EXEMPLE : Nom usager = Rossi ; **Code** = 015.

- Dans le cas d'une installation **Simplebus top**, l'usager est identifié par les champs **Nom Usager** (option) et par un champ **Code** comprenant 2 parties ; champ zone de 3 chiffres maximum (compris entre 1 et 500) et champ usager comptant **impérativement** 3 chiffres (compris entre 1 et 240).

EXEMPLE : Nom usager = Rossi ; **Code** = 25 015 ;

2- Appel indirect, l'appel a lieu en tapant le code indirect à 6 chiffres maximum. Ce code doit être présent au répertoire et associé à l'usager possédant un nom (obligatoire) et un code Simplebus (ou Simplebus TOP).

Pour activer la fonction :

- appuyer sur la touche **MENU** et sur les touches ▼▲ pour afficher le menu **Configurations** puis appuyer sur la touche **OK** ;



- appuyer sur les touches ▼▲ pour afficher le menu **Système** puis appuyer sur **OK** ;

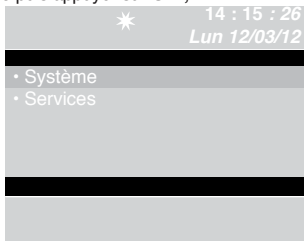

- appuyer sur les touches ▼▲ pour afficher le menu **Appel** puis appuyer sur **OK** ;

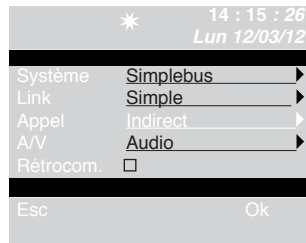

- sélectionner Simplebus ou Indirect à l'aide des touches ◀▶ ;
- appuyer sur la touche **OK** pour confirmer les réglages ;
- appuyer plusieurs fois sur la touche **ESC** pour retourner à la page principale.

C5 - Rétrocompatibilité

Elle est désactivée par défaut.

ATTENTION !

Valider cette fonction pour éviter tout dysfonctionnement en cas de présence d'articles ayant un indice de révision (IR.) inférieur à ceux qui sont mentionnés dans le tableau page 94.

Pour valider la fonction :

- appuyer sur la touche **MENU** et sur les touches ▼▲ pour afficher le menu **Configurations** puis appuyer sur la touche **OK** ;

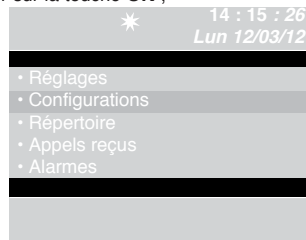

- appuyer sur les touches ▼▲ pour afficher le menu **Système** puis appuyer sur **OK** ;

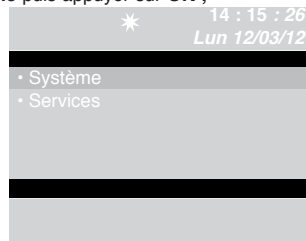

- appuyer sur les touches ▼▲ pour afficher le menu **Rétrocom.** puis appuyer sur **OK** ;

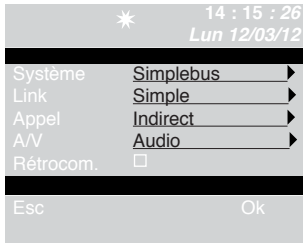

Valider le service Rétrocom. à l'aide de la touche **▶**. Désactiver en appuyant sur **◀**.

- appuyer sur la touche **OK** pour confirmer les réglages ;
- appuyer plusieurs fois sur la touche **ESC** pour retourner à la page principale.

C6 - Appel audio ou vidéo

Appel audio par défaut.

En activant l'appel vidéo, il sera possible d'effectuer un appel vidéo vers un poste intérieur. Le moniteur appelé par le standard s'allumera en permettant par exemple de voir les caméras déportées associées à l'Art. 1259/A ou à l'Art. 1259/C (voir FT/SB/13 ou FT/SBC/05).

Lorsque la rétrocompatibilité est désactivée - par défaut (voir C5 - Rétrocompatibilité page 93), le vidéo s'allume immédiatement au moment de l'appel entre standard et poste intérieur.

Lorsque la rétrocompatibilité est validée, le vidéo s'allume sur prise phonie au moment de l'appel entre standard et poste intérieur.

Pour valider l'appel audio ou vidéo :

- appuyer sur la touche **MENU** et sur les touches **▼▲** pour afficher le menu **Configurations** puis appuyer sur la touche **OK** ;

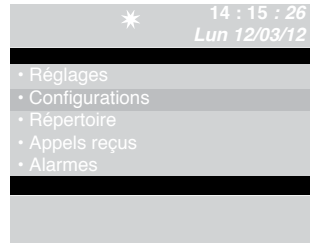

- appuyer sur les touches **▼▲** pour afficher le menu **Système** puis appuyer sur **OK** ;

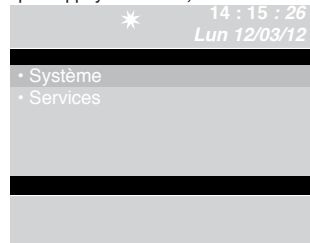

- appuyer sur les touches **▼▲** pour afficher le menu **AV** puis appuyer sur **OK** ;

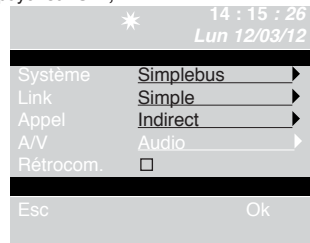

- sélectionner **Audio** ou **Vidéo** à l'aide des touches **◀▶**.
- appuyer sur la touche **OK** pour confirmer les réglages ;
- appuyer plusieurs fois sur la touche **ESC** pour retourner à la page principale.

Tableau articles Simplebus TOP

Étriers	Art. 5714C IR. 007 - Art. 5814C IR. 002, Art. 6114C IR. 015
Combinés parlophoniques	Art. 2608 IR. 006 - Art. 2610 IR. 008 Art. 2619 IR. 000 - Art. 2628 IR. 005 Art. 2638 IR. 006
Commutateurs	Art. 1424 IR. 002
Mélangeurs	Art. 4888C IR. 013
Platines de rue	Art. 1602 IR. 027 - Art. 1602VCF IR. 002, Art. 3340 IR. 021 - Art. 3342 IR. 021 Art. 3070/A IR. 010 - Art. 3072/A IR. 010, Art. 4660C IR. 013
Standards	Art. 1998A IR. 006 - Art. 1998V IR. 001, Art. 1998VC IR. 001
Logiciel	Art. 1249/A IR. 002



C7- Configuration services

FollowMe (« Suivi ») :

Elle est désactivée par défaut.

ATTENTION !

Pour utiliser cette fonction, la centrale Art. 2906 avec interface Art. 2912 doit être présente. S'adresser à l'installateur de confiance.

Cette fonction n'est activable que sur le standard programmé comme secondaire (voir « C1 Type de standard » page 91).

Cette fonction permet de dévier les appels destinés au standard vers les appareils téléphoniques locaux ou à distance.

À la suite d'un appel, le standard sonnera de toute manière et tant que l'appareil à distance n'entrera pas en communication, il sera possible de répondre à l'appel depuis le standard en annulant la fonction « Suivi ».

Répétition d'appel :

permet de choisir la temporisation de la fermeture du contact entre 1 et 30 secondes (voir « I8 - Réglage temps » page 87).

Allumage postes int. :

Elle est désactivée par défaut.

ATTENTION !

Cette fonction n'est disponible que pour les installations Simplebus non TOP et la présence de l'Art. 1259 est nécessaire pour la vision cyclique des caméras déportées.

Cette fonction permet d'activer ou de désactiver l'auto-allumage envoyé par les postes intérieurs avec standard en modalité JOUR.

Appel triple :

Elle est désactivée par défaut.

Cette fonction permet d'activer ou de désactiver l'appel triple du standard vers les postes intérieurs.

L'appel sera effectué 3 fois de suite (en cas d'appel vidéo : les 2 premiers seront audio, le troisième sera vidéo).

Aide codes :

Elle est désactivée par défaut.

Permet d'augmenter les codes Simplebus sur la ligne montant.

Pour valider les services :

- appuyer sur la touche **MENU** et sur les touches ▼ ▲ pour afficher le menu **Configurations** puis appuyer sur la touche **OK** ;



- appuyer sur les touches ▼ ▲ pour afficher le menu **Services** puis appuyer sur **OK** ;

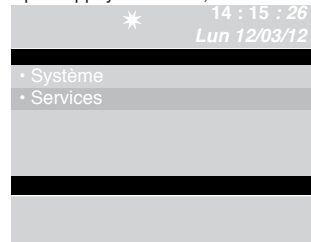

- appuyer sur les touches ▼ ▲ pour afficher le service à valider (followMe, répétition d'appel, allumage postes intérieurs, appel triple, aide codes). Valider le service à l'aide de la touche ►. Désactiver en appuyant sur ◀.

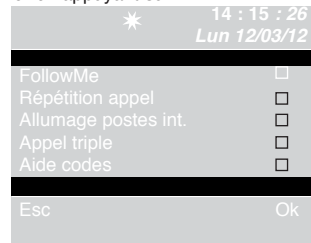

- appuyer sur la touche **OK** pour confirmer les réglages ;
- appuyer plusieurs fois sur la touche **ESC** pour retourner à la page principale.

SB2V/EN/103M

- Ⓜ Impianto videocitfonico Simplebus b/n con 1 ingresso principale e centralino di portineria
- Ⓔ Simplebus B/W video entry phone system with 1 main input and porter switchboard
- Ⓡ Installation parlophonique et visiophonique Simplebus n/b avec 1 entrée principale e standard de conciergerie

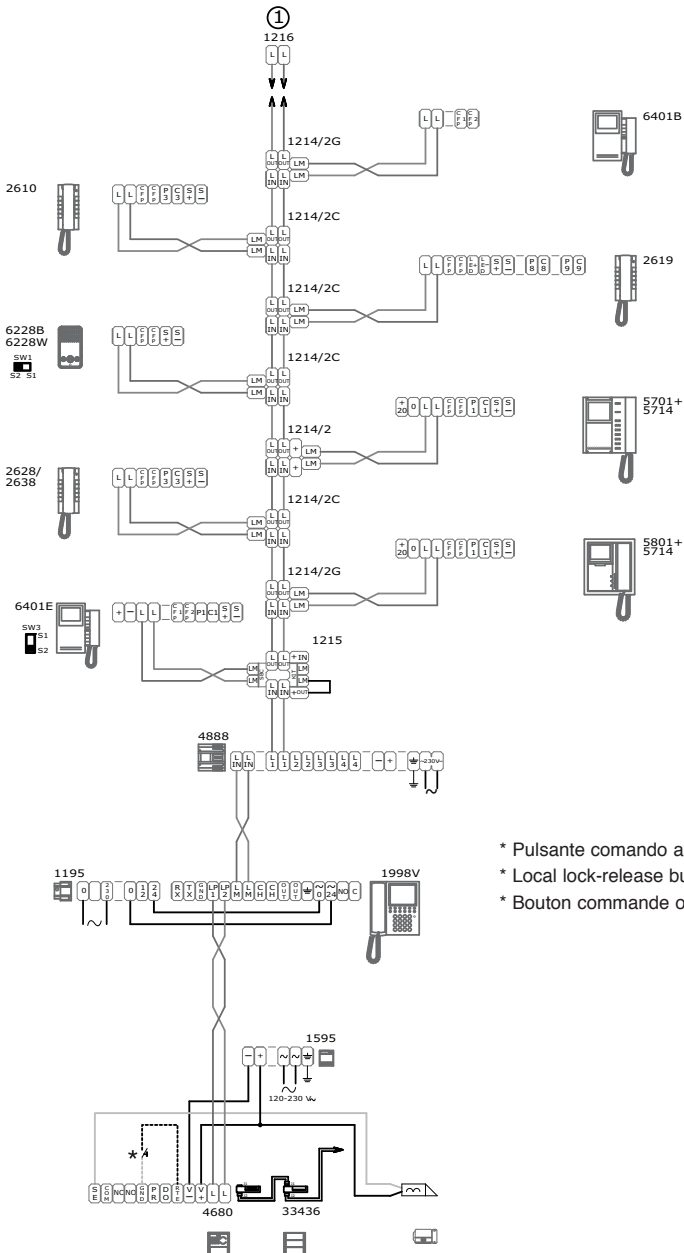

- * Pulsante comando apriporta locale
- * Local lock-release button
- * Bouton commande ouvre-porte local

SB2V/EN/105M

- IT** Impianto videocitofonico Simplebus b/n con 2 ingressi principali e centralino di portineria
- EN** Simplebus B/W video entry phone system with 2 main inputs and porter switchboard
- FR** Installation parlophonique et visiophonique Simplebus n/b avec 2 entrées principales e standard de conciergerie

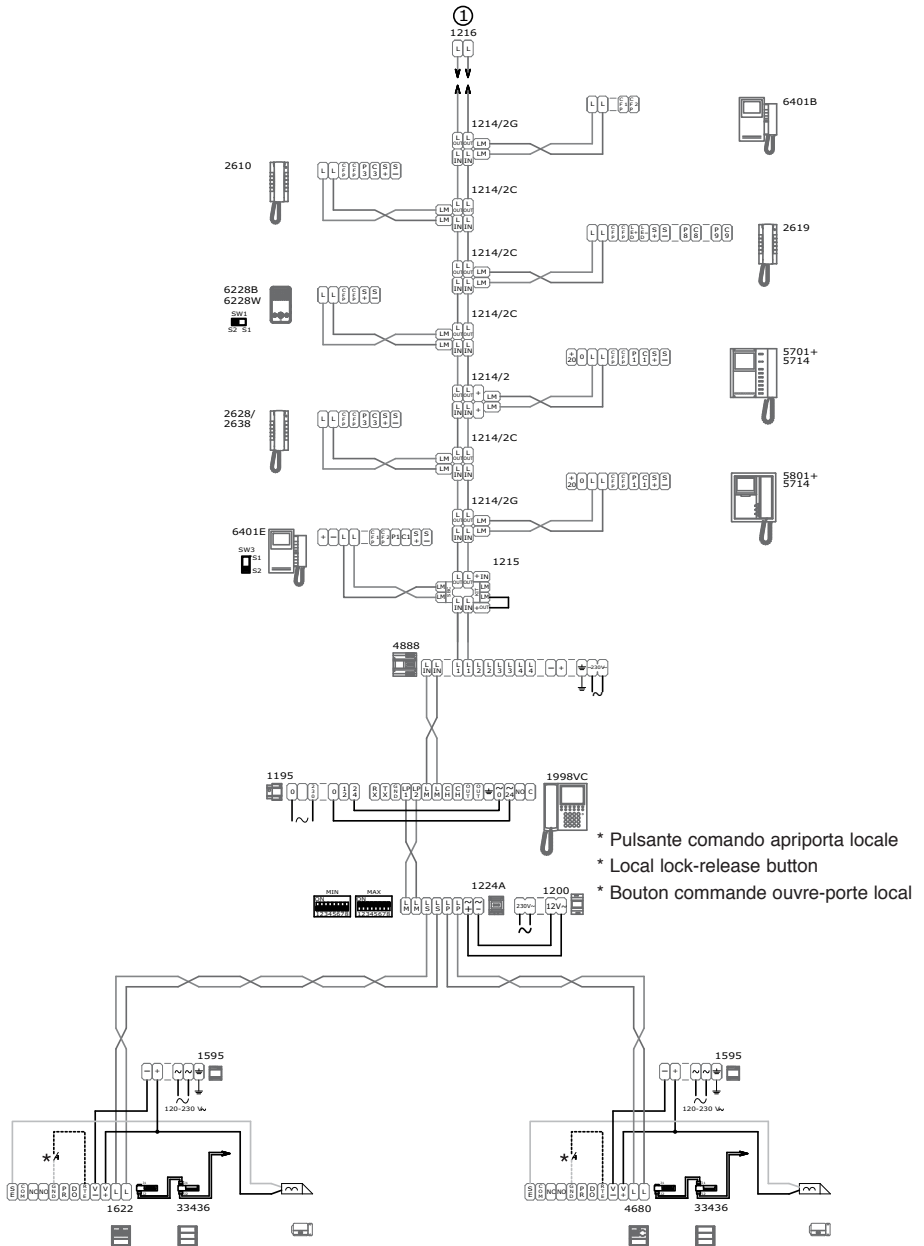

SB2V/EN/105SMC

- IT** Impianto videocitfonico Simplebus Color con 2 ingressi principali e centralino di portineria
- EN** Simplebus Color video entry phone system with 2 main inputs and porter switchboard
- FR** Installation parlophonique et visiophonique Simplebus Color avec 2 entrées principales et standard de conciergerie

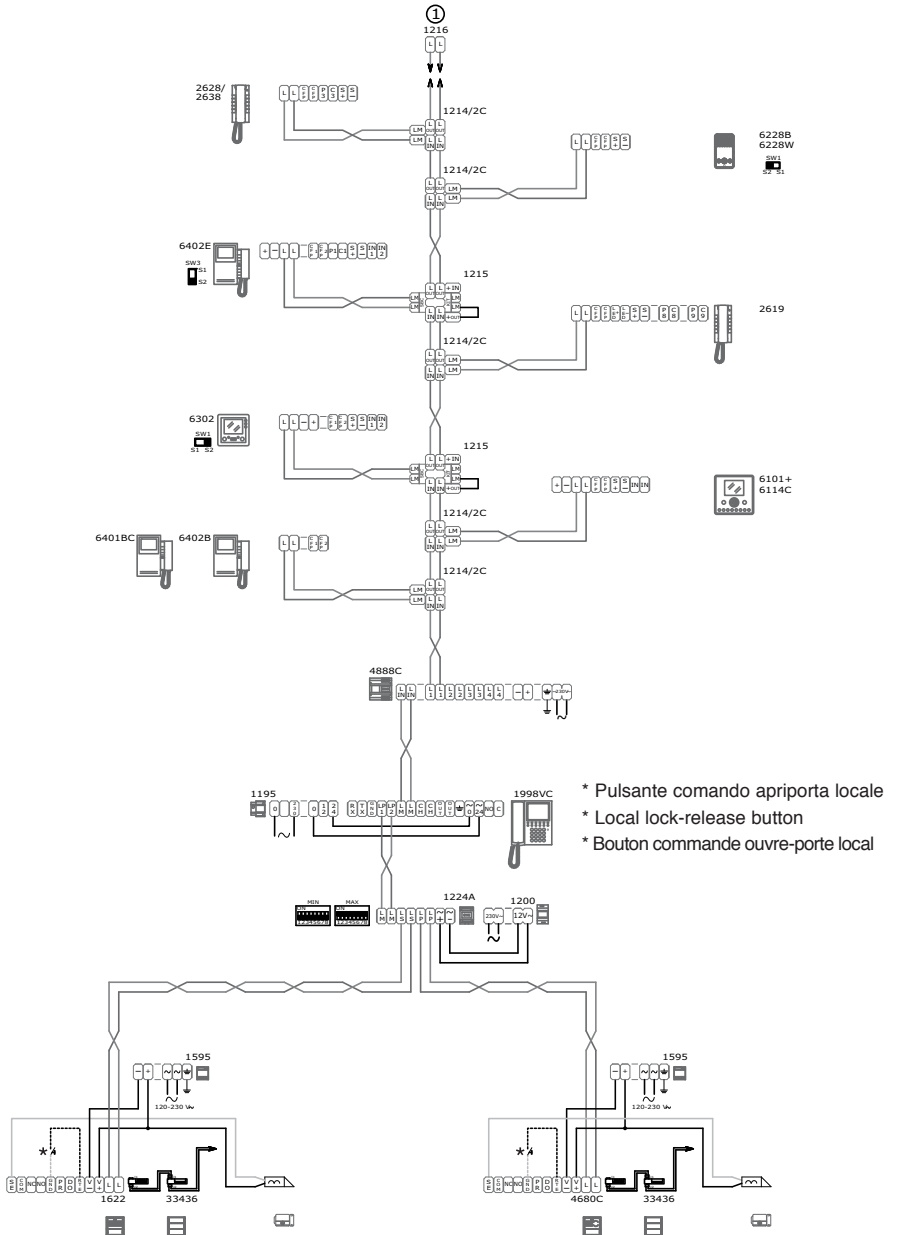

SB2V/018ASMC

- Ⓜ Impianto Simplebus Color con modulo telecamera scorporata Art. 1259C in modalità attuatore generico e centralino di portineria
- Ⓝ Simplebus Color system with remote camera module Art. 1259C in generic actuator mode and porter switchboard
- Ⓡ Installation Simplebus Color avec module caméra déportée Art. 1259C en mode actionneur générique et standard de conciergerie

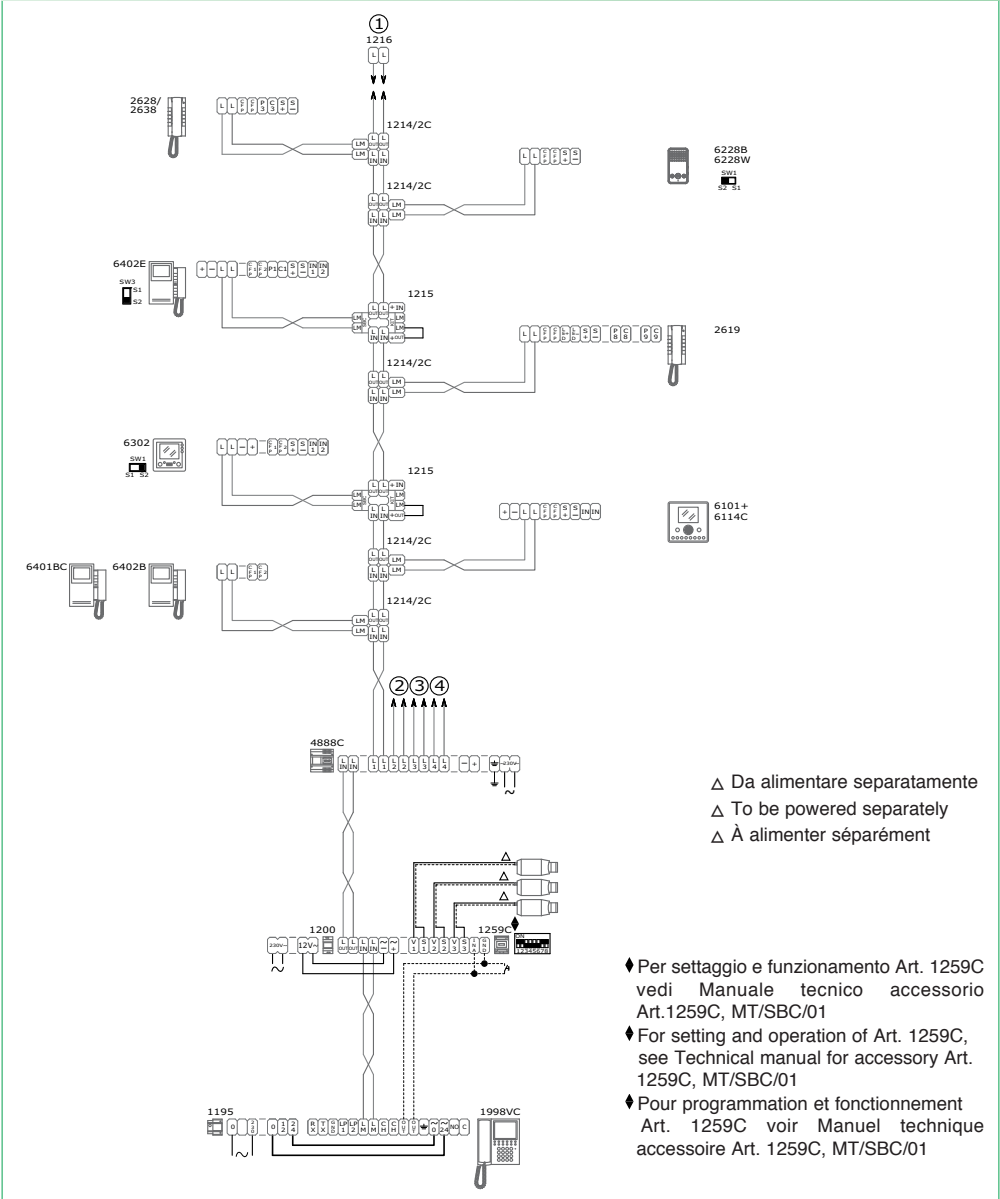

SB2V/026SMC

- Ⓜ Impianto videocitofonico con 1 ingresso principale e centralino di portineria abbinato al centralino telefonico Art. 2906 per follow-me
- Ⓝ Video entry phone system with 1 main input and porter switchboard used in conjunction with telephone switchboard Art. 2906 for Follow me mode
- Ⓡ Installation parlophonique et visiophonique avec 1 entrée principale et standard de conciergerie associé au standard téléphonique Art. 2906 pour follow-me

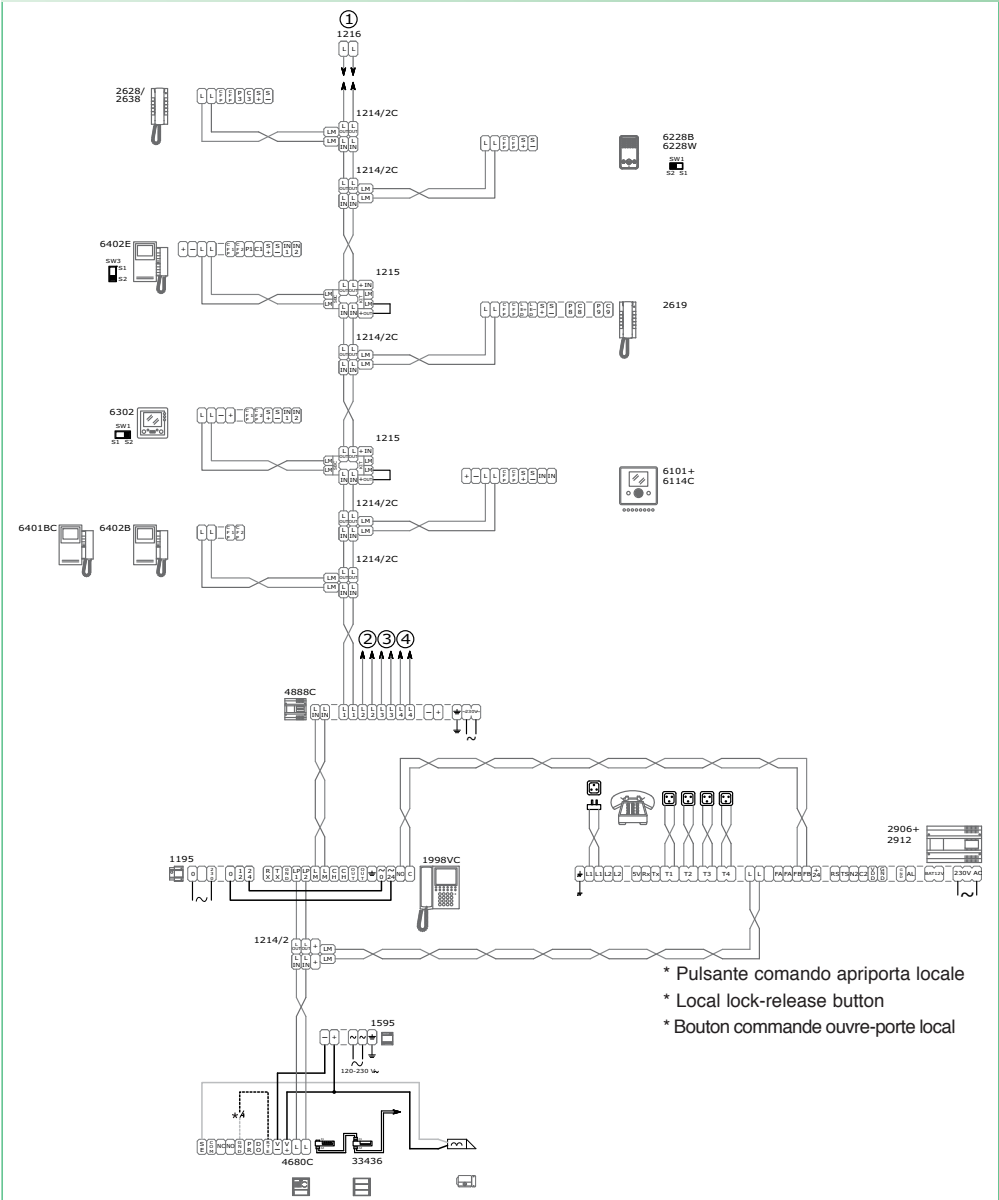

- * Pulsante comando apriporta locale
- * Local lock-release button
- * Bouton commande ouvre-porte local

SB2V/EN/101M

- IT** Impianto videocitfonico Simplebus b/n con 1 ingresso principale, 3 secondari video e centralino di portineria
- EN** Simplebus B/W video entry phone system with 1 main input, 3 secondary video inputs and porter switchboard
- FR** Installation parlophonique et visiophonique Simplebus n/b avec 1 entrée principale, 3 secondaires vidéo et

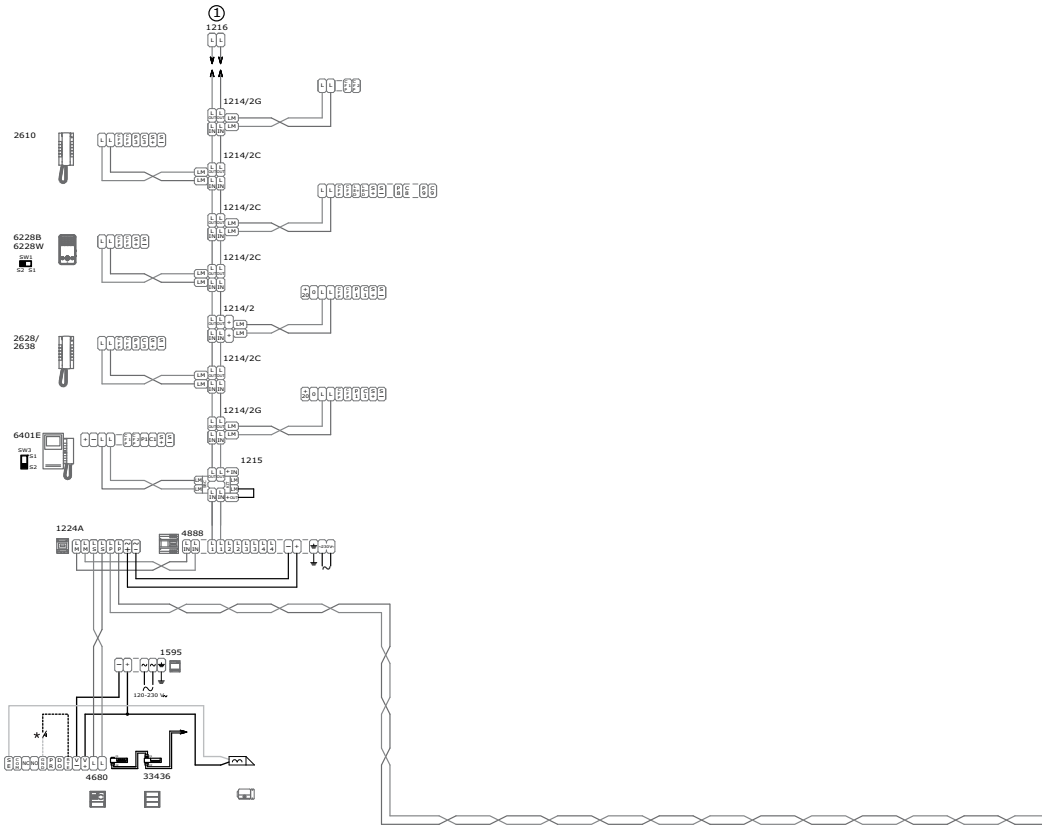

standard de conciergerie

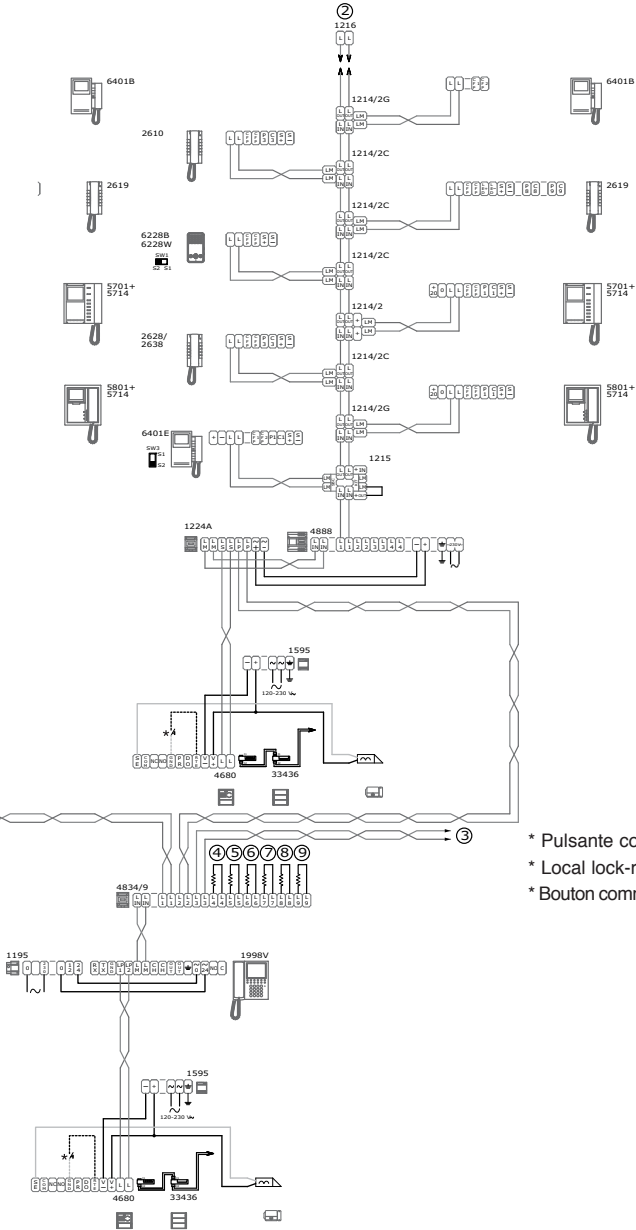

- * Pulsante comando apriporta locale
- * Local lock-release button
- * Bouton commande ouvre-porte local

SB2V/EN/101SMC

- IT** Impianto videocitfonico Simplebus Color con 1 ingresso principale, 3 secondari video e centralino di portineria
- EN** Simplebus Color video entry phone system with 1 main input, 3 secondary video inputs and porter switchboard
- FR** Installation parlophonique et visiophonique Simplebus Color avec 1 entrée principale, 3 secondaires vidéo et

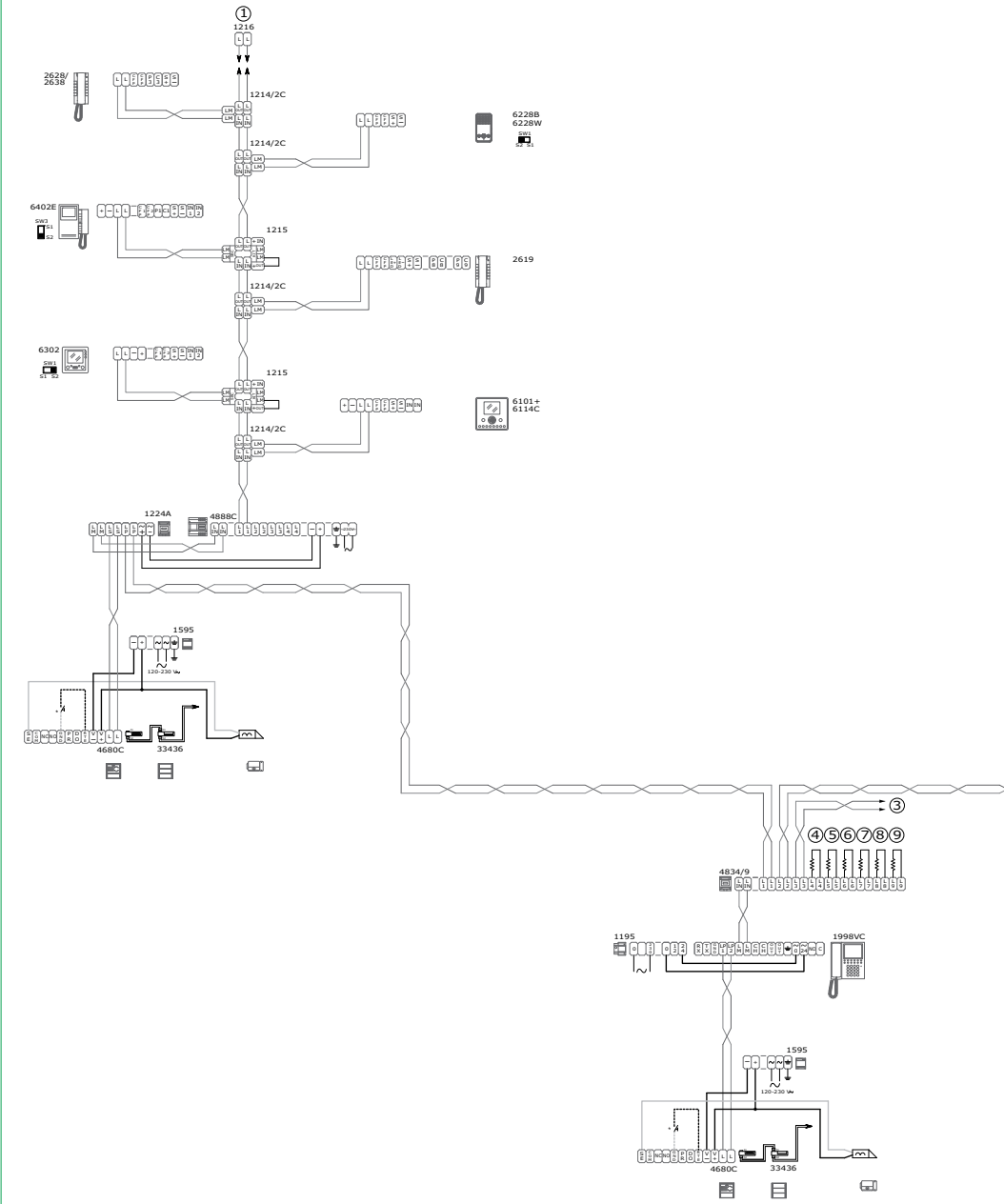

standard de conciergerie

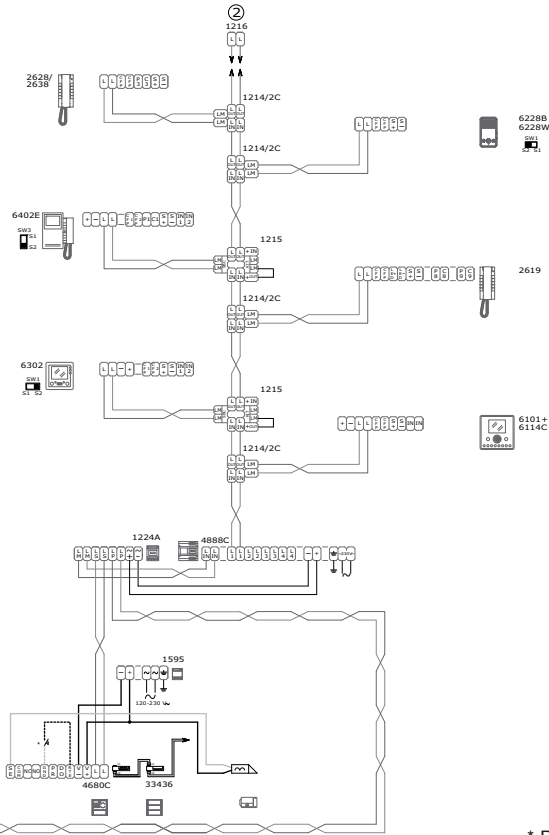

- * Pulsante comando apriporta locale
- * Local lock-release button
- * Bouton commande ouvre-porte local

SB2V/EN/121DM

- IT Impianto videocitfonico Simplebus b/n con 2 ingressi principali, 3 secondari audio e centralino di portineria
- EN Simplebus B/W video entry phone system with 2 main inputs, 3 secondary audio inputs and porter switchboard
- FR Installation parlophonique et visiophonique Simplebus n/b avec 2 entrées principales, 3 secondaires audio

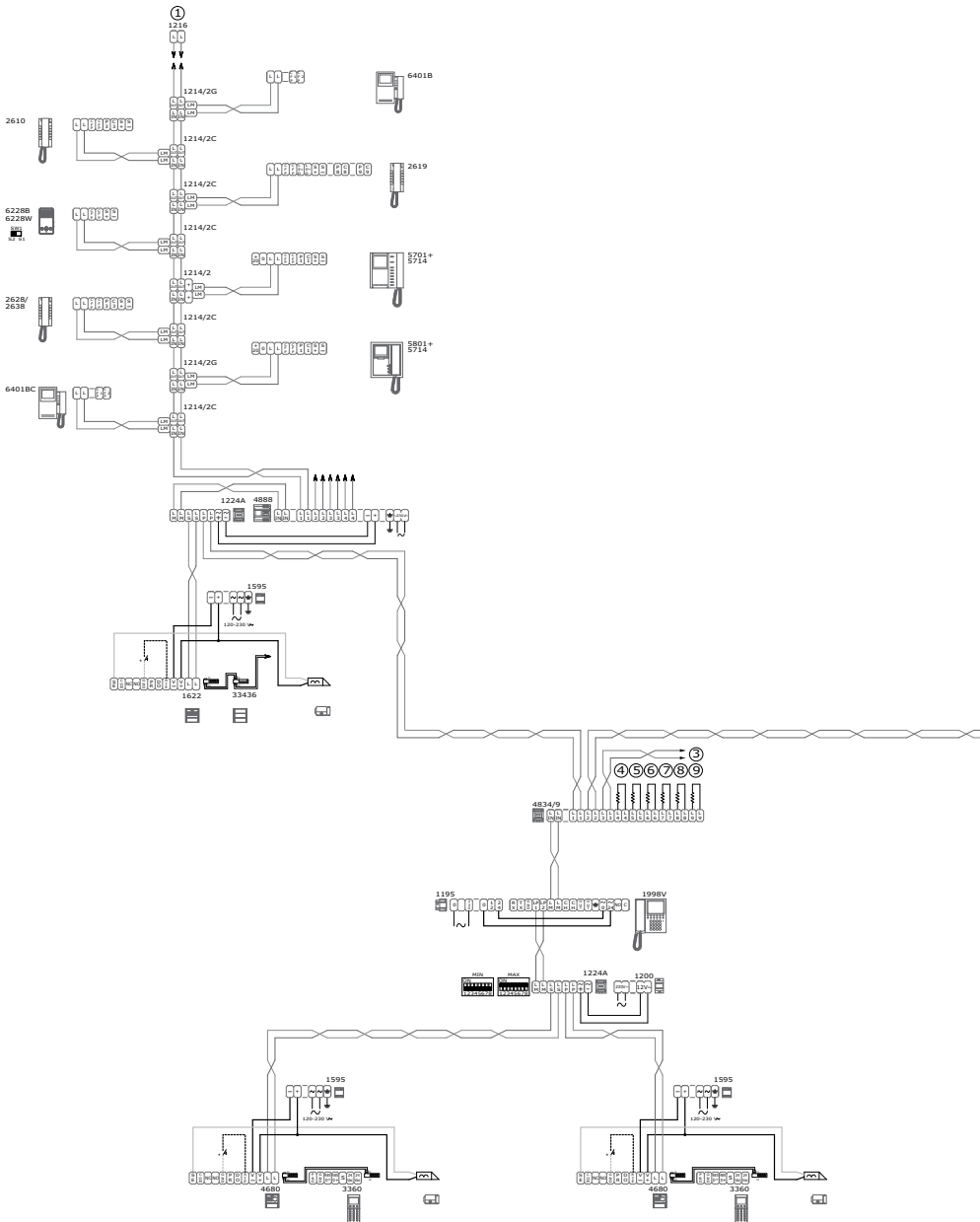

et standard de conciergerie

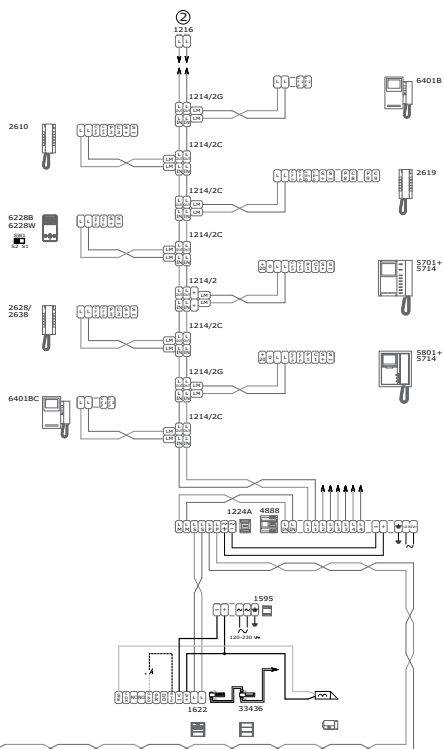

- * Pulsante comando apriporta locale
- * Local lock-release button
- * Bouton commande ouvre-porte local

SB2V/EN/121DSMC

- IT** Impianto videocitfonico Simplebus Color con 2 ingressi principali, 3 secondari audio e centralino di portineria
- EN** Simplebus Color video entry phone system with 2 main inputs, 3 secondary audio inputs and porter switchboard
- FR** Installation parlophonique et visiophonique Simplebus Color avec 2 entrées principales, 3 secondaires audio et

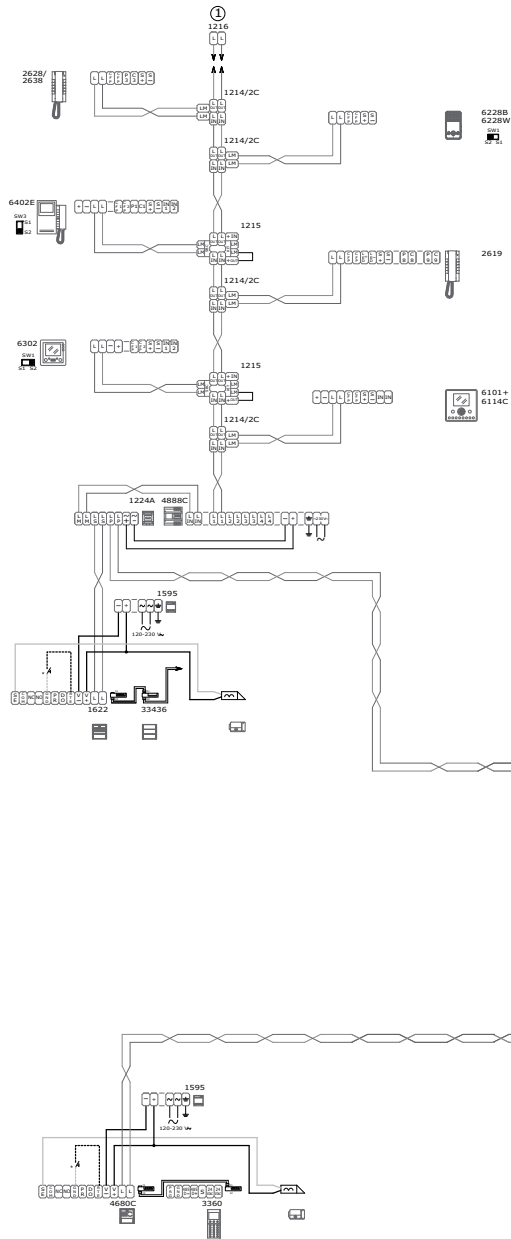

standard de conciergerie

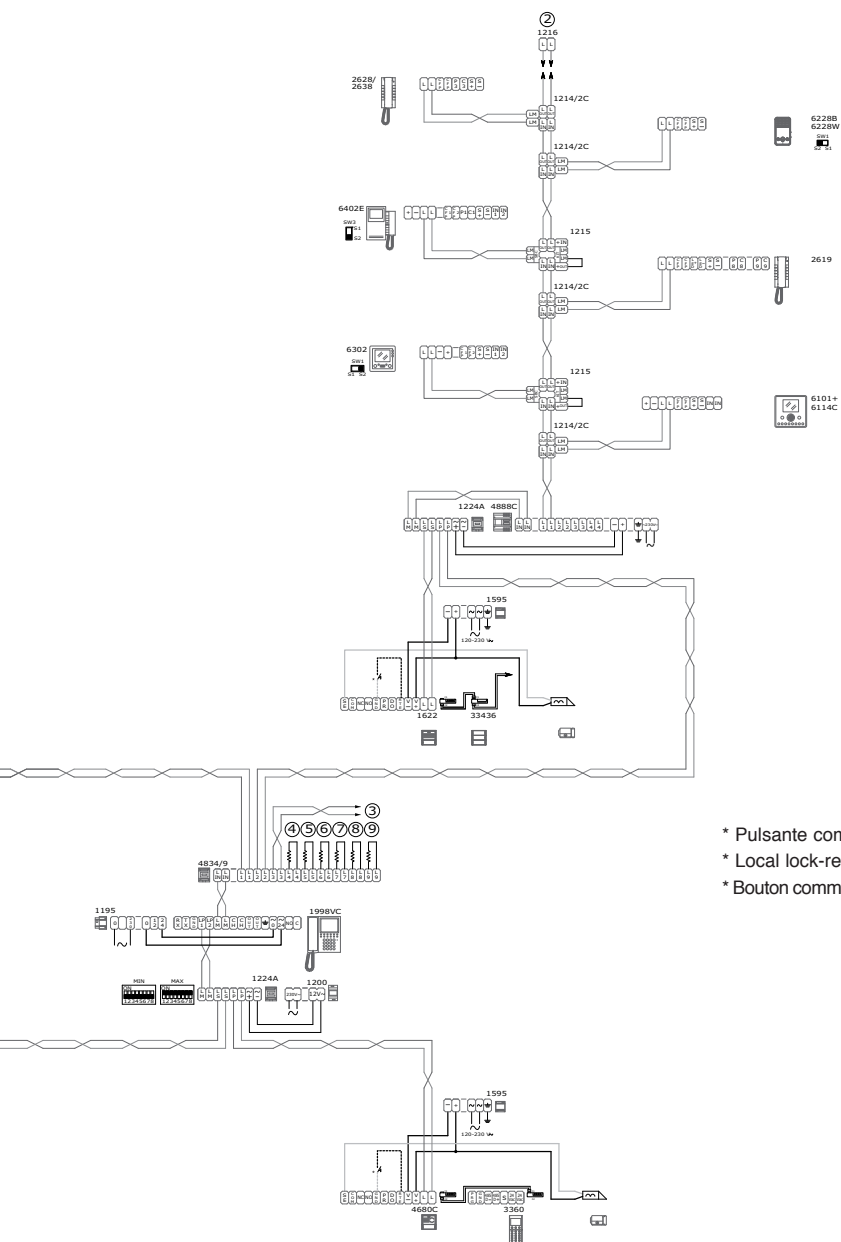

- * Pulsante comando apriporta locale
- * Local lock-release button
- * Bouton commande ouvre-porte local

SBTOP/001DSMC

- Ⓜ Impianto videocitofonico Simplebus TOP con 1 ingresso principale, 4 secondari e relativi centralini di
- Ⓝ Simplebus TOP video entry phone system with 1 main input, 4 secondary inputs and corresponding
- Ⓡ Installation parlophonique et visiophonique Simplebus TOP avec 1 entrée principale, 4 secondaires et

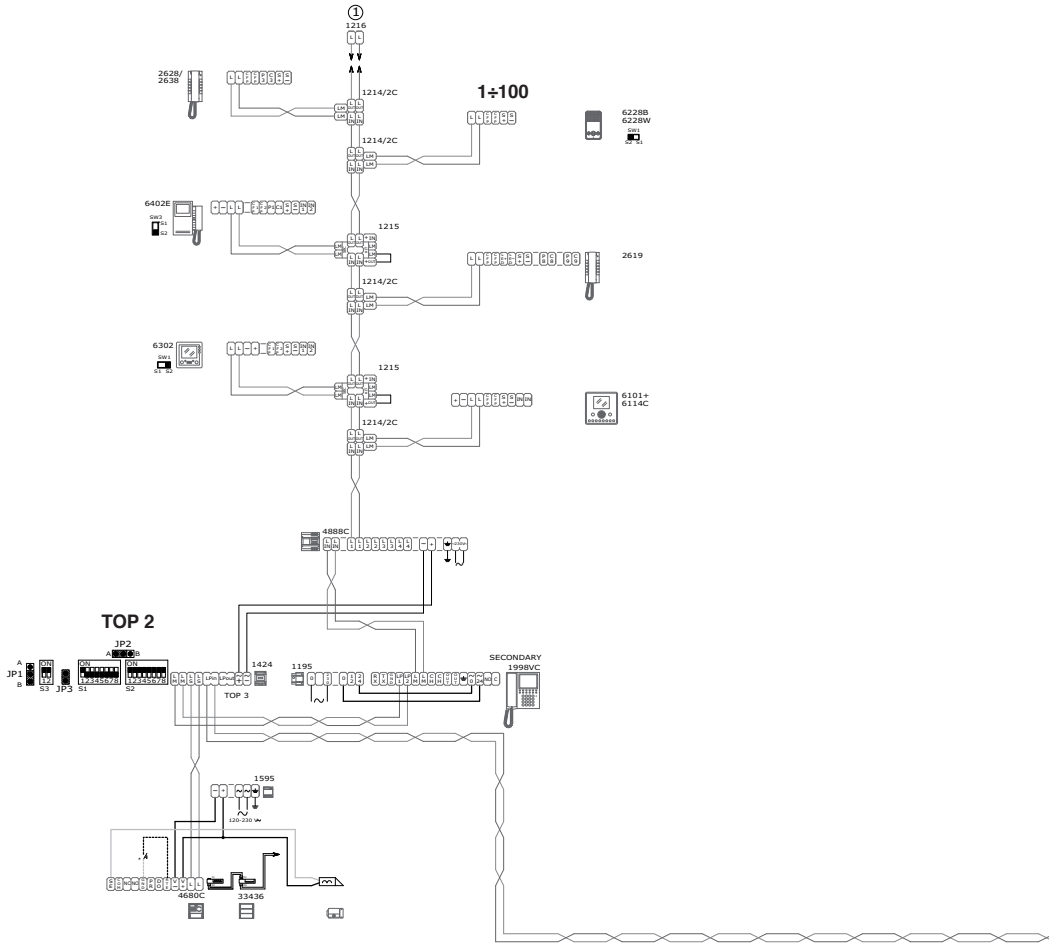

SBTOP/003DSMC

- (IT)** Impianto videocitofonico Simplebus TOP con 2 ingressi principali, 1 centralino di portineria principale, 2
- (EN)** Simplebus TOP video entry phone system with 2 main inputs, 1 main porter switchboard, 2 secondary inputs
- (FR)** Installation parlophonique et visiophonique Simplebus TOP avec 2 entrées principales, 1 standard de

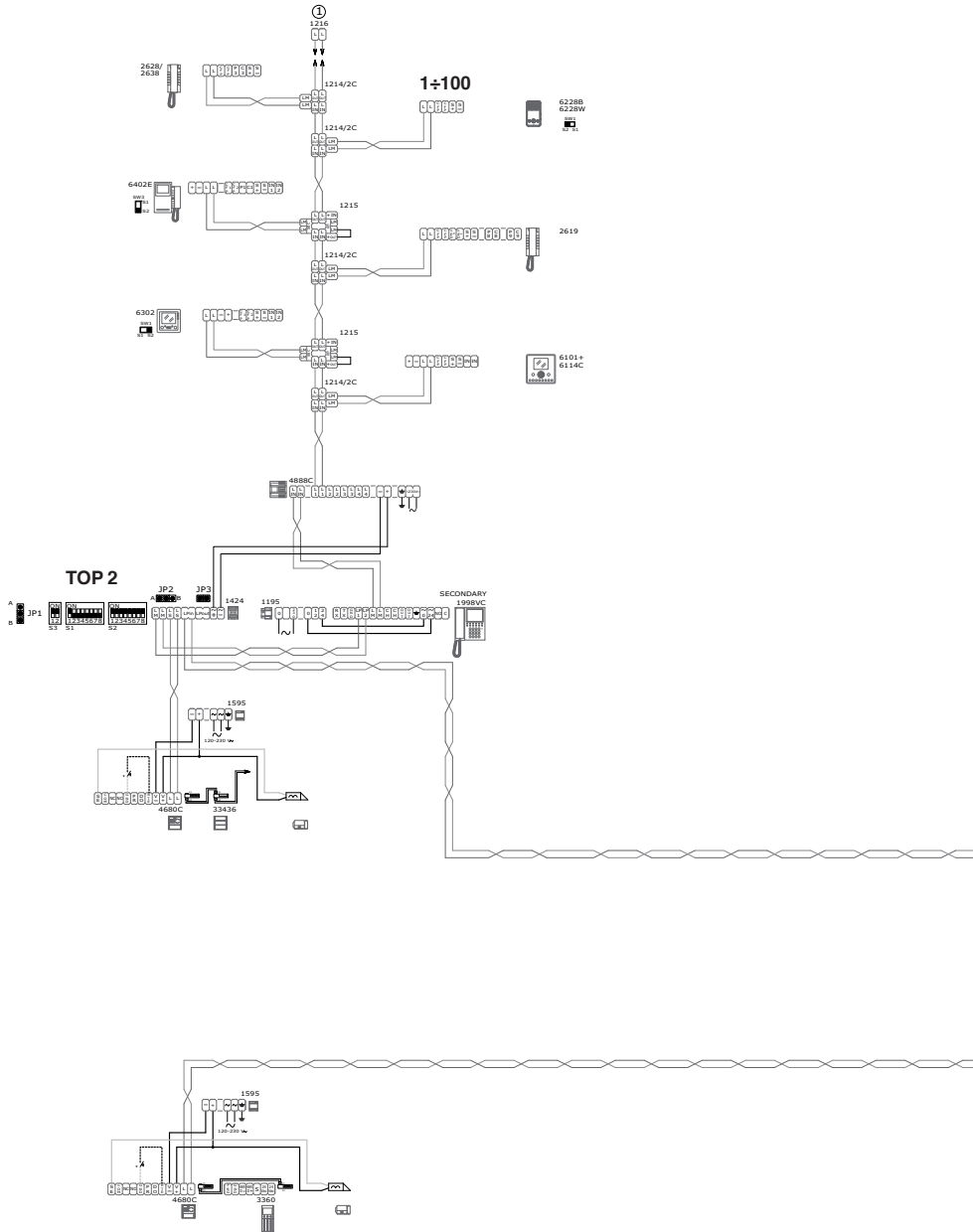

**secondari e relativi centralini di portineria secondari
and corresponding secondary porter switchboards
conciergerie principal, 2 secondaires et standards de conciergerie secondaires correspondants**

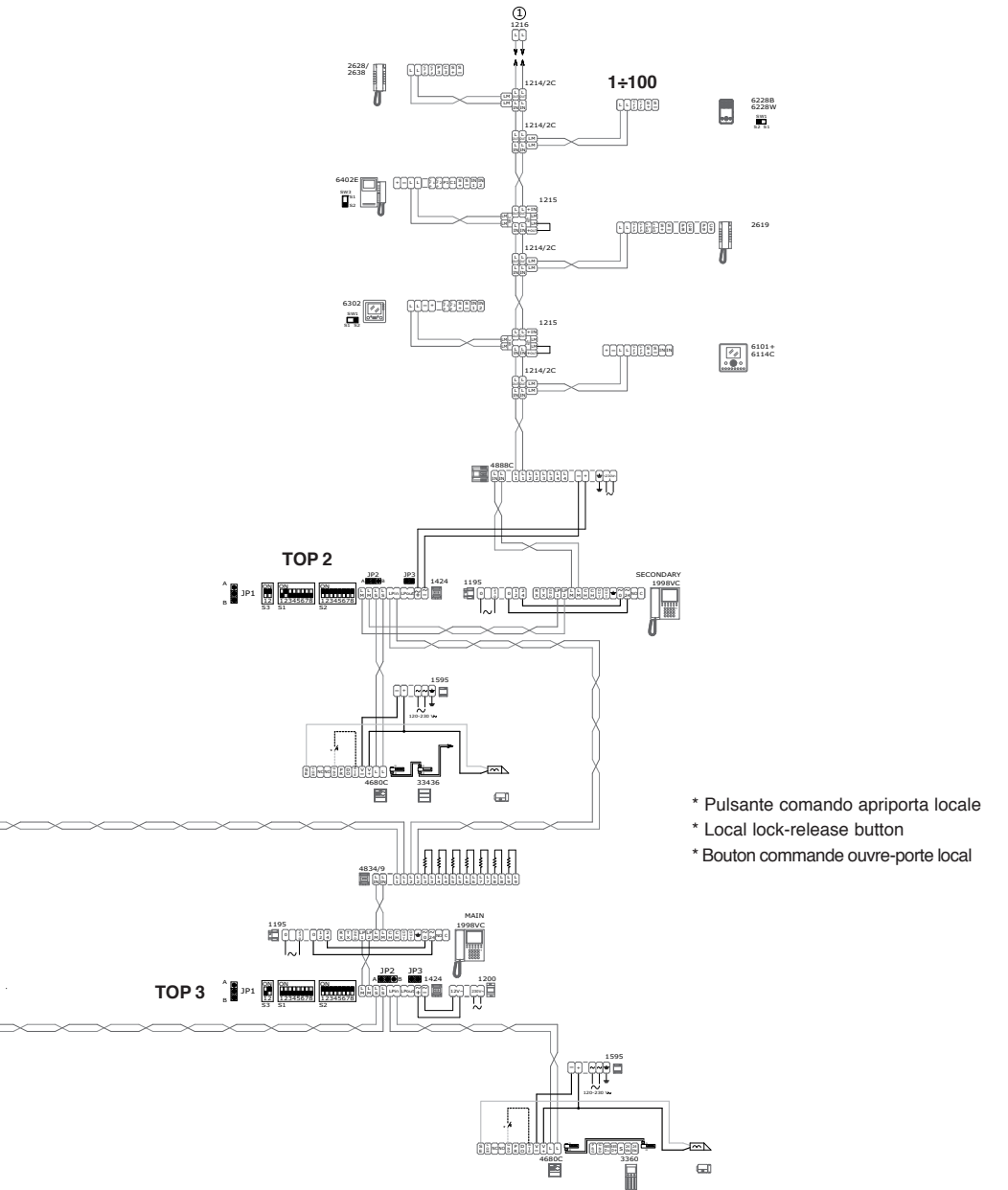

- * Pulsante comando apriporta locale
- * Local lock-release button
- * Bouton commande ouvre-porte local

SBTOP/004DSMC

- IT** Impianto videocitofonico Simplebus TOP con 1 ingresso principale, 4 secondari e 2 centralini di portineria
- EN** Simplebus TOP video entry phone system with 1 main input, 4 secondary inputs and 2 main porter
- FR** Installation parlophonique et visiophonique Simplebus TOP avec 1 entrée principale, 4 secondaires et 2

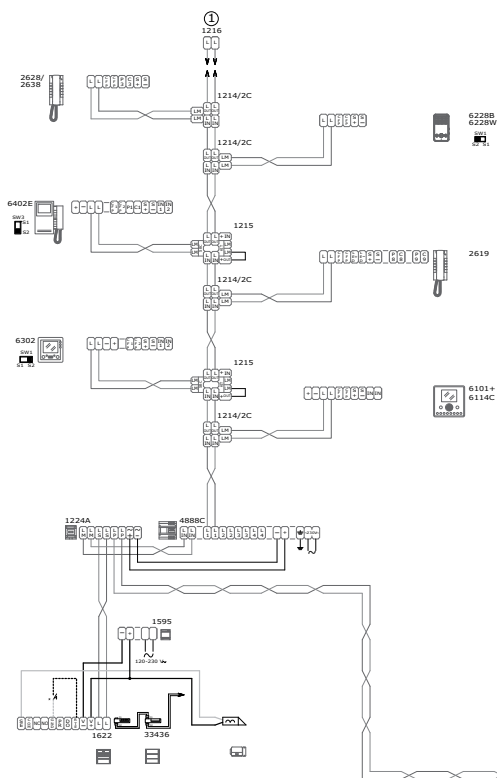

principali in configurazione SERIE
 switchboards configured in SERIES
 standards de conciergerie principaux en configuration SÉRIE

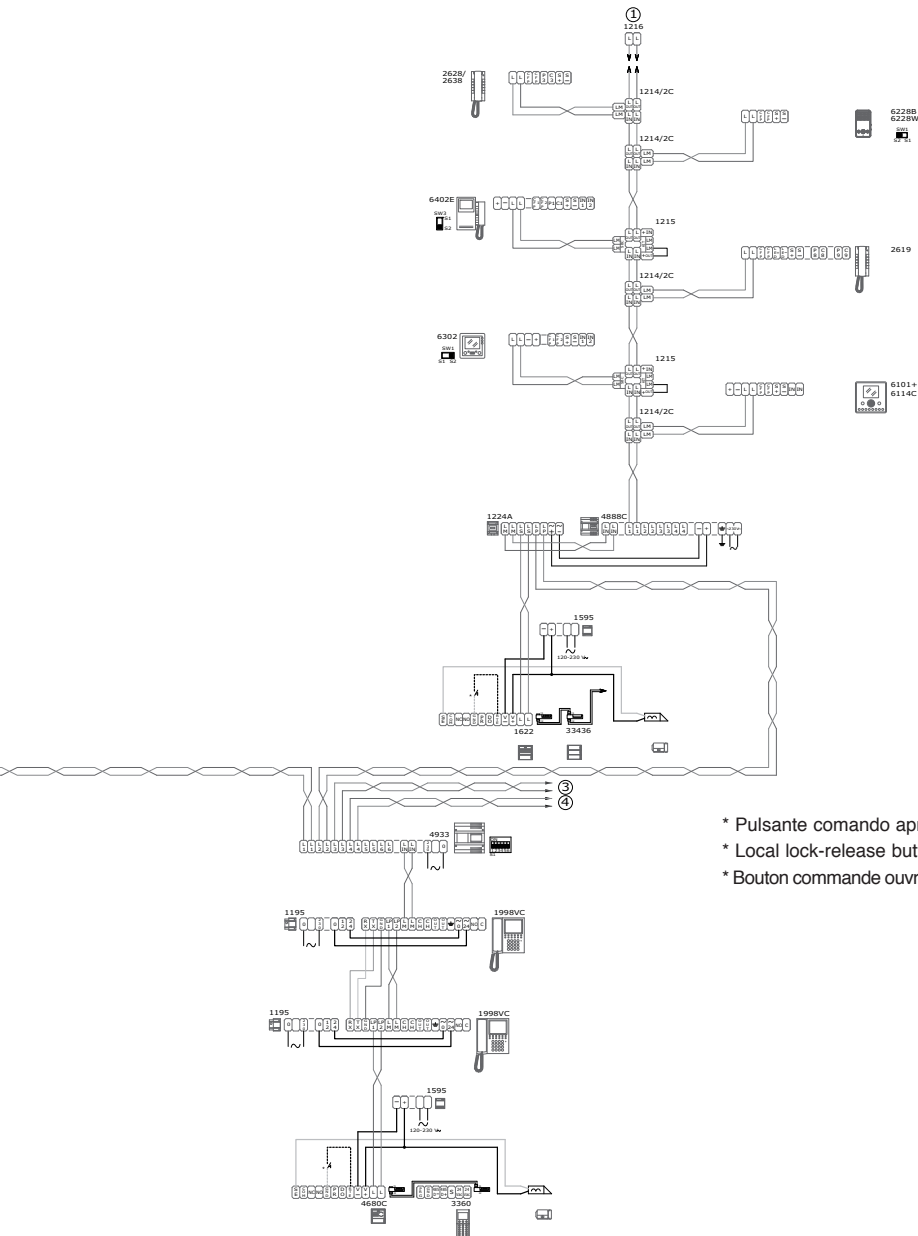

- * Pulsante comando apriporta locale
- * Local lock-release button
- * Bouton commande ouvre-porte local

SBTOP/005DSMC

- IT** Impianto videocitofonico Simplebus TOP con 1 ingresso principale, 3 secondari e 2 centralini di portineria
- EN** Simplebus TOP video entry phone system with 1 main input, 3 secondary inputs and 2 main porter
- FR** Installation parlophonique et visiophonique Simplebus TOP avec 1 entrée principale, 3 secondaires et 2

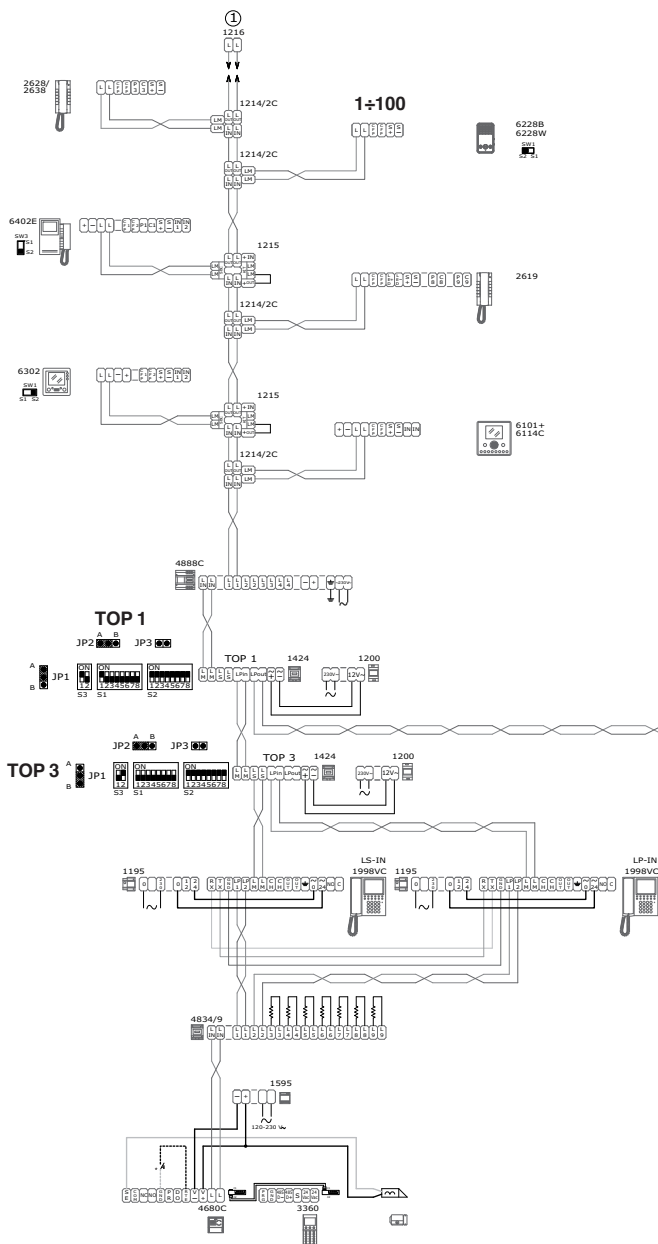

principali in configurazione PARALLELO
 switchboards configured in PARALLEL
 standards de conciergerie principaux en configuration PARALLÈLE

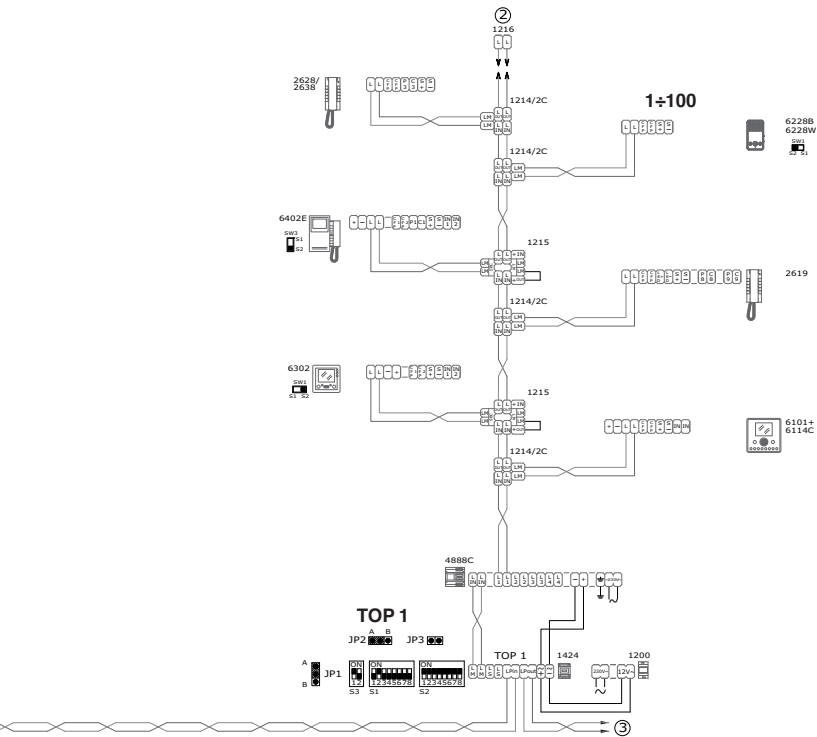

- * Pulsante comando apriporta locale
- * Local lock-release button
- * Bouton commande ouvre-porte local

