

FERMAX

TECHNICAL MANUAL VDS SYSTEM

Section I

Description of the VDS System

VDS TECHNICAL MANUAL

The VDS technical manual is comprised of two sections:

- Section I: Description of the VDS System (Code 97508I-1)
- Section II: VDS Installation Diagrams (Code 97508I-2)

VDS Technical Manual- Section I
Code 97508I-1 V07_09

This technical document of an informative nature is published by FERMAX ELECTRONICA S.A.E., who reserve the right to modify the technical characteristics of the products referred to herein at any time and without prior notice. These changes will be reflected in subsequent editions of this document.

TABLE OF CONTENTS
SECTION I - DESCRIPTION OF THE VDS SYSTEM

VDS SYSTEM 5

- General Features 5
- Basic diagram for a VDS video door entry system 7
- The VDS system in REPLACEMENT installations. 8
- VDS System Operating Principles 10
- Installation and Start-Up Instructions for VDS systems 12

VDS PANELS 13

- VDS Amplifier 14
 - New Cityline Panels 16
 - Cityline, Marine and Bruto Panels 18
 - Halo Panels 19
- NEW CITYLINE Panels 20
 - Button Panels. - Continuous Profile 20
 - Call Extension Module 21
 - Button Panels. Modular 22
 - Button Module Interconnection 23
 - DIRECT Panels (keypad) 24
 - DIGITAL Panels (keypad + display) 26
- VDS Guard Unit 28

BASIC VDS SYSTEM DEVICES 31

- VDS Switcher 32
- Video Distributors 33
- VDS System Power Supplies 34
- Lock-Releases: Continuous and Alternating Lock Release Connection 35

ACCESSORIES FOR VDS SYSTEMS 36

RESIDENTIAL TERMINALS 37

- Audio Terminals: VDS Telephone Terminals 37
- Video Terminals: VDS Monitors 38
- Connectors and Connections 39
- VDS Terminal Programming (monitors and telephones) 40

ADVANCED PROGRAMMING:

- Mapping (button panels) 41
- Lock-Release Times on Button Panels 42

VDS SYSTEM

We call this easy-to-install electronic door entry system or video door entry system designed by FERMAX ELECTRONICA a VDS system, the main identifying feature of which is that it does not use call wires.

The traditional VDS system does not require the usual call wire for every telephone or monitor. The panel call is converted into a digital signal which is sent via a common wire. This digital signal is only recognised by the telephone or monitor programmed, generating the corresponding audio call signal.

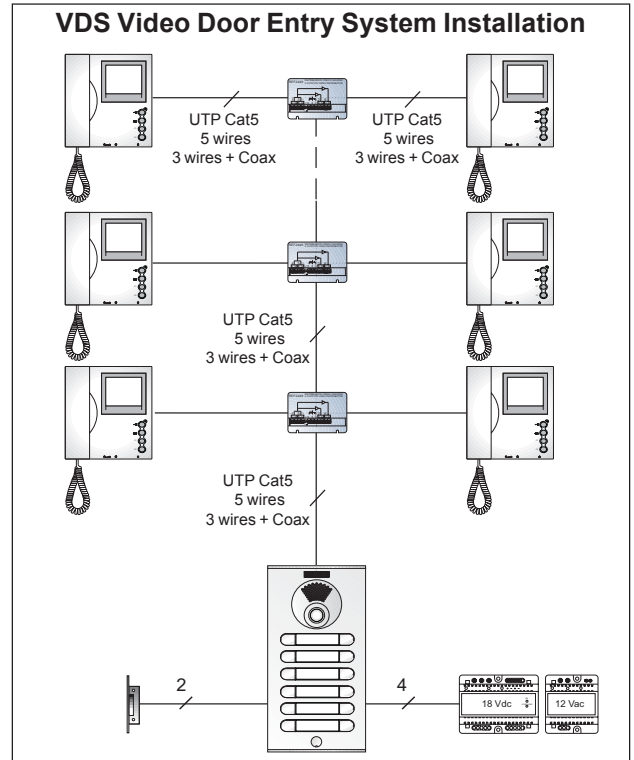
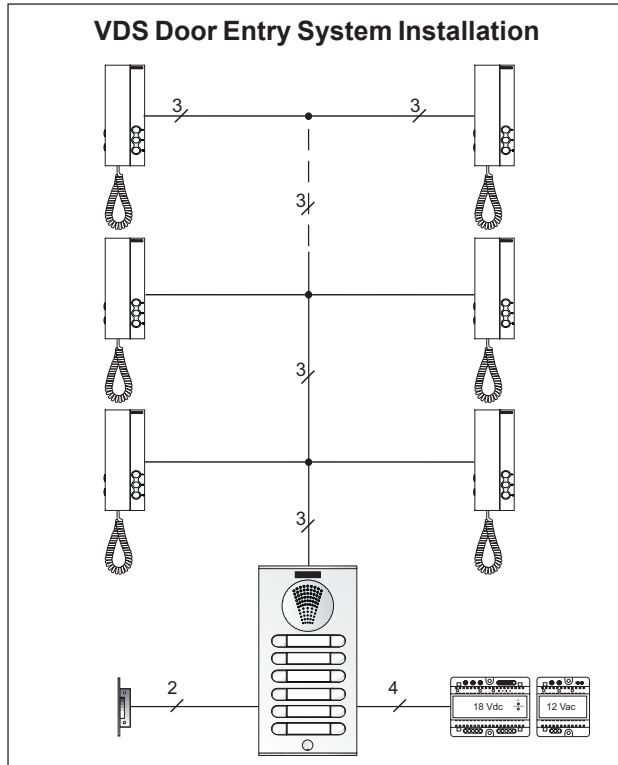

Main Features of the VDS System

*** Simplified Wire Installation**

- **Door Entry System:** 3 wires.

- **Video Door Entry System:**

· New Building: UTP CAT5, 5 wires or 3 wires + coaxial.

· Replacement: the VDS system allows you to change a 4+N electronic door system to a video door system using the existing wiring.

*** Maximum Distance: 200 m**

- UTP Cat5 / 5 wires (*): up to 100 m

- 3 wires(*)+ coaxial: up to 200 m.

(* see the section/distance table in the 'Installation and Start-Up Instructions for VDS systems' section.

*** Up to 199 apartments with door entry system or video door entry system.**

· New Building: the VDS system can manage buildings with up to 199 apartments.

· Replacement: the system capacity depends on the existing wiring.

*** Easy start-up process**

Once the VDS system has been wired, a simple programming procedure is carried out to assign a number (call number) to each telephone or monitor. If the residence has more than one telephone and/or monitor, these devices can be programmed with the same number. In this case, all devices will ring when the residence's doorbell is rung.

*** One or two door entry system or video door entry system access points (entrances)**

The VDS system enables up to two access points to be installed in the same building, with the possibility of combining audio and video entry devices.

For buildings which initially had only one access point, adding a door entry or video door entry panel at a second access point requires minimum installation.

*** Access Control Accessories**

The VDS Direct and Digital systems incorporate access control functions using codes input via the panels' numerical keypad, (previously programmed using the keypad).

The VDS Digital systems can also incorporate secondary proximity readers as access controls

*** Privacy (total confidentiality) for conversations**

Under no circumstances is the user able to listen in on any outside conversation established between another residence and the entry panel or guard unit. The same applies for conversations between terminals installed in the same apartment.

As soon as a call is made to a telephone or monitor, system operation for the remaining terminals is paused (for a pre-established time period). As a result, even pressing the auto-start button will not allow the user to see the remote camera image or listen to the conversation of another user until the pre-established time period has expired or the receiver on the terminal called has been replaced.

*** Auto-Start**

All monitors are equipped with an auto-start button which can be used to connect to the entry panels at any time or to view the image recorded by the remote camera and listen to sounds outside, providing that the system is not being used by another monitor or telephone (privacy). In this case a 'beep' noise will be heard upon pressing the auto-start button, acting as confirmation that the channel is engaged.

*** Simple Extensions. Option to connect various pieces of equipment in each residence**

There is the option to combine VDS telephones and monitors including advanced security and domestic functions.

Various monitors and/or telephones can easily be installed in the same residence: A telephone can connect to any other telephone or monitor in the system with just three wires.

*** Programming Lock-Release Times**

The VDS system allows the lock-release time to be set at between 1 and 99 seconds.

*** Easy extension to the MDS-VDS system**

Enclosures with various exterior access points (MDS) to different interior blocks (VDS) can be created quickly and easily. (For more information, please consult the MDS-VDS diagram).

Basic Diagrams of VDS electronic DOOR ENTRY systems

Basic Wiring: 3 wires.

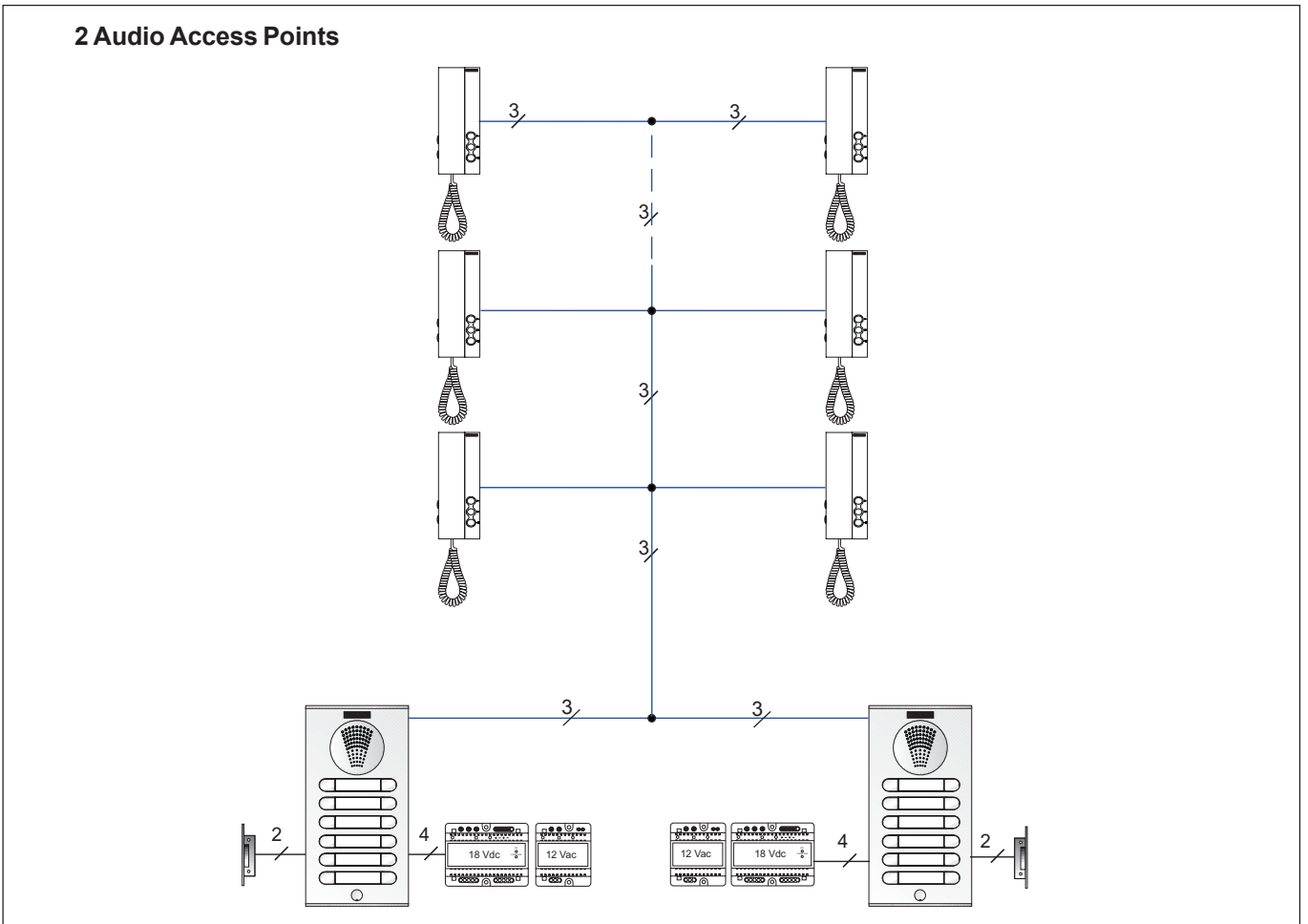
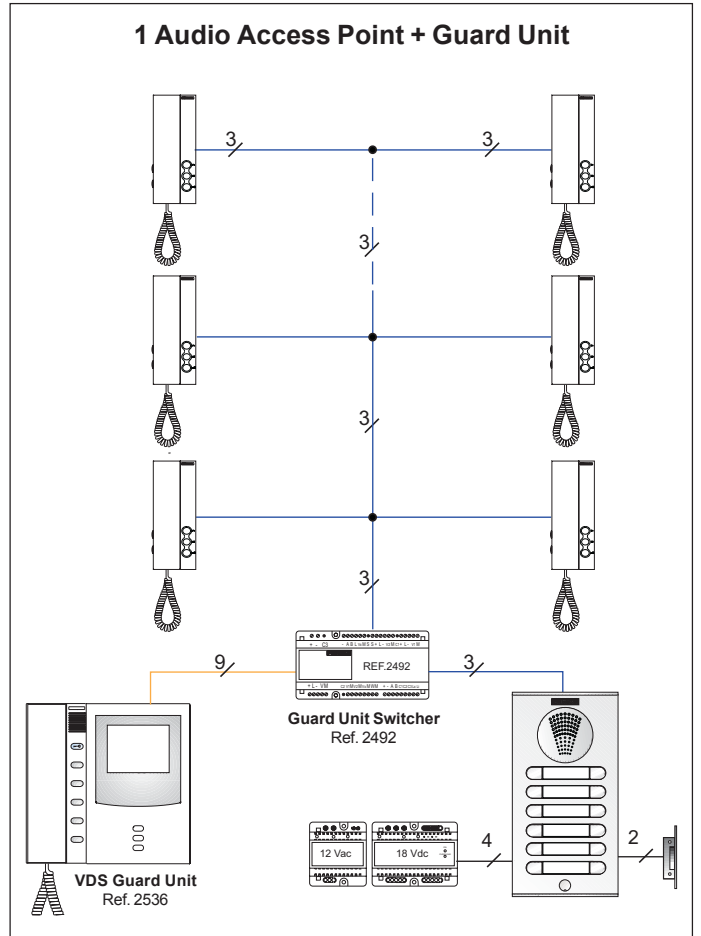
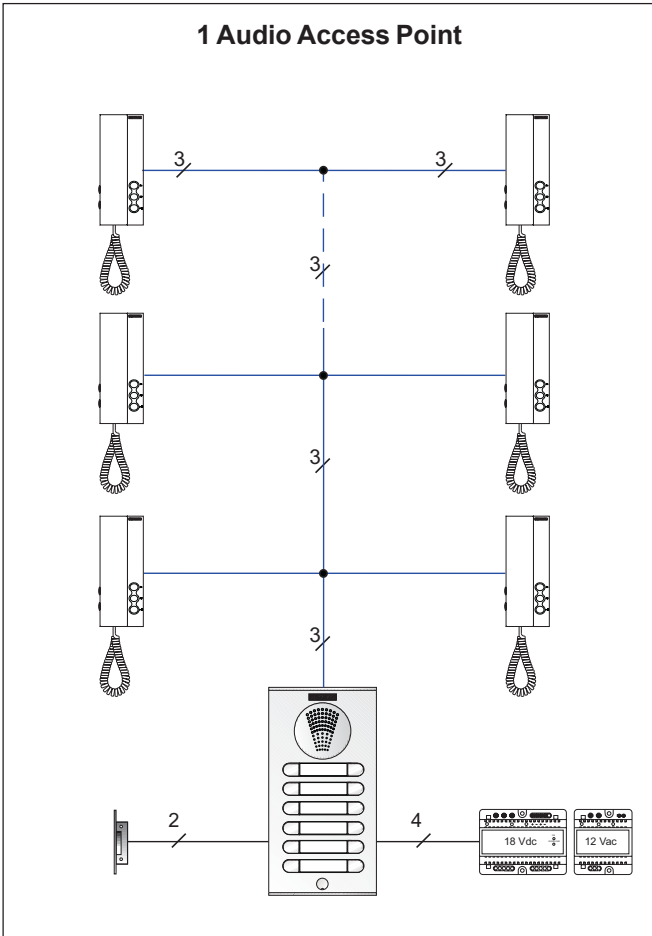

Basic Diagrams of VDS VIDEO DOOR ENTRY systems

Basic Wiring: UTP Cat5 / 5 wires/ 3 wires + Coaxial.

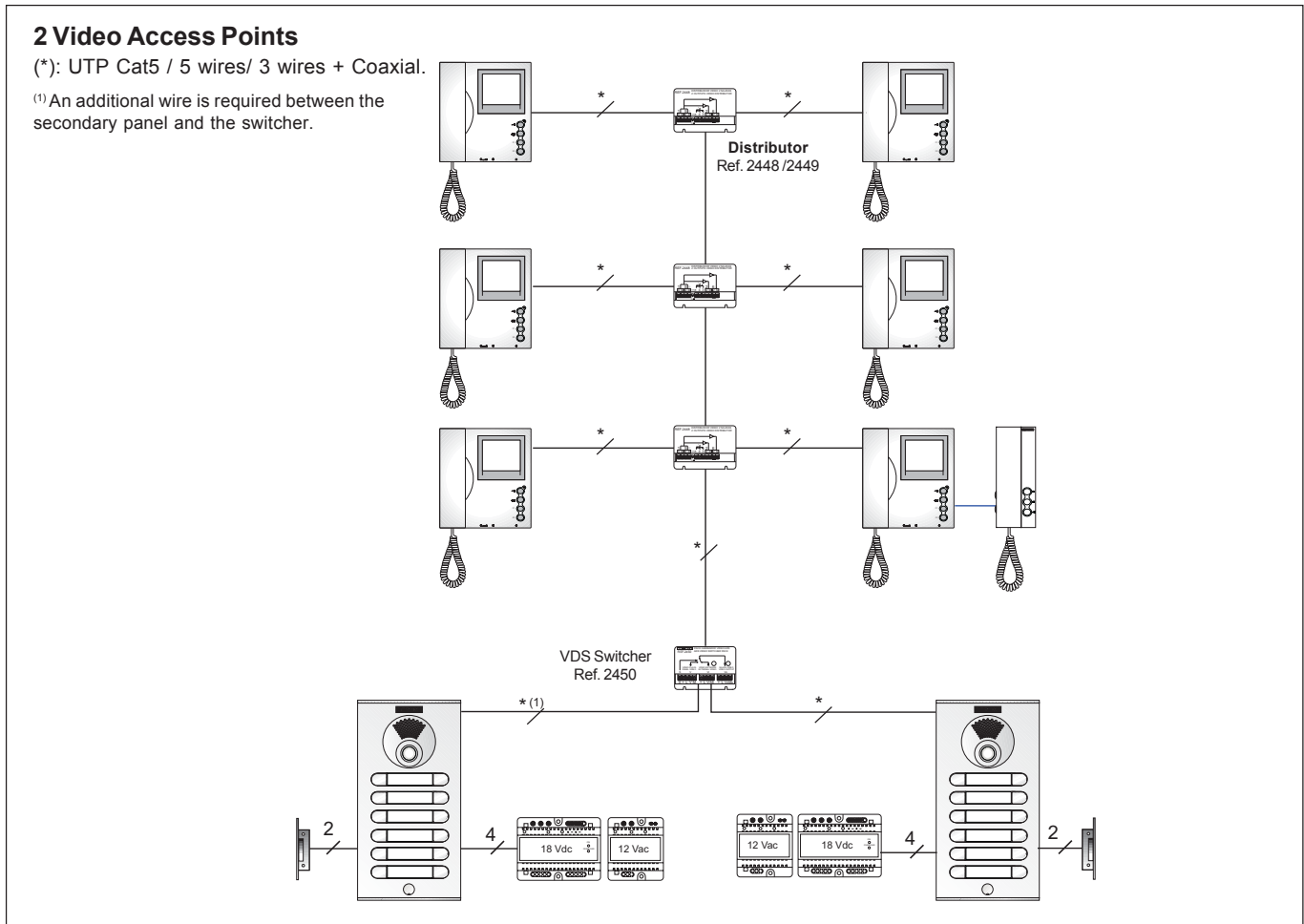
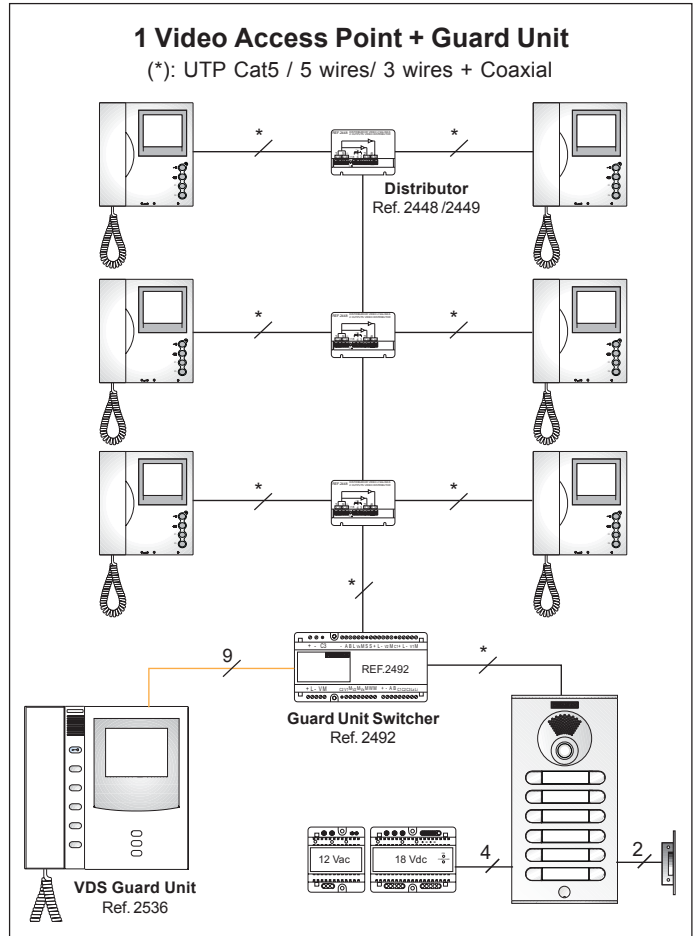
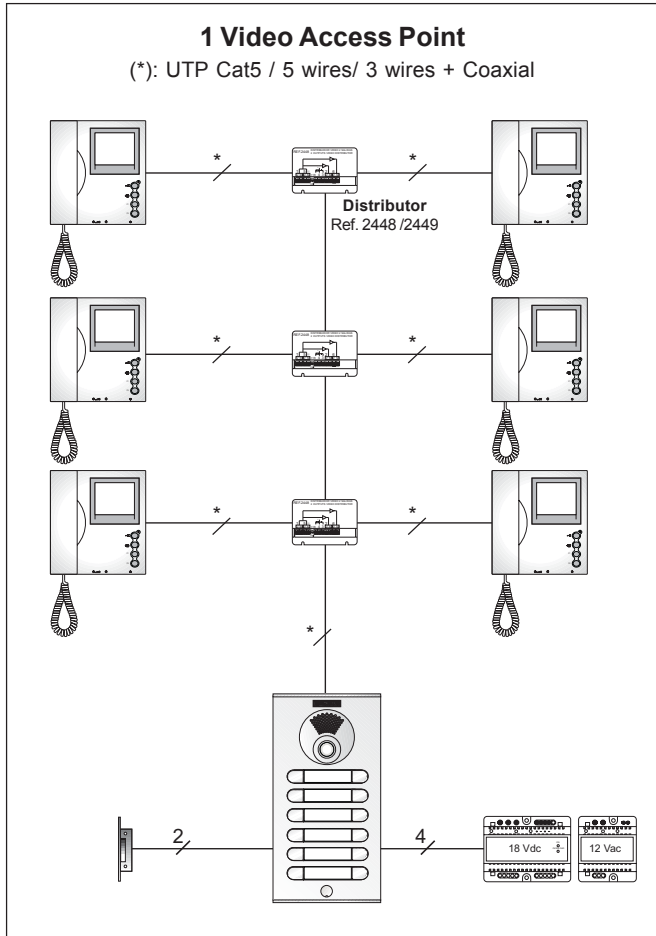

The VDS system in REPLACEMENT systems

Given its features and resources the VDS system is the ideal system for the replacement of a door entry system with a video door entry system.

Allows the use of the door entry system's existing wiring to convert it to a digital video door entry system.

Conventional door entry systems, which generally consist of 4 common wires + 1 call wire per residence can be converted to 5 wire Fermax **VDS video door entry systems**, without the need to replace the existing wiring.

To convert this system to a 5 wire bus, you must connect all the call wires on the entry panel and use them as a negative wire on the system (see system diagram).

Facilitates systems with up to 199 residences, 2 entrance points and a central guard unit with a maximum distance of 100 metres. The distance can be extended depending on the system characteristics.

4+N Door Entry System
 4 common wires + N (1 call wire per residence)
Common Audio Wires: 1,2: Residence-Entry Panel Audio Direction
 3,6: Entry Panel-Residence Audio Direction
Call Wires: N1, N2, N3 ...

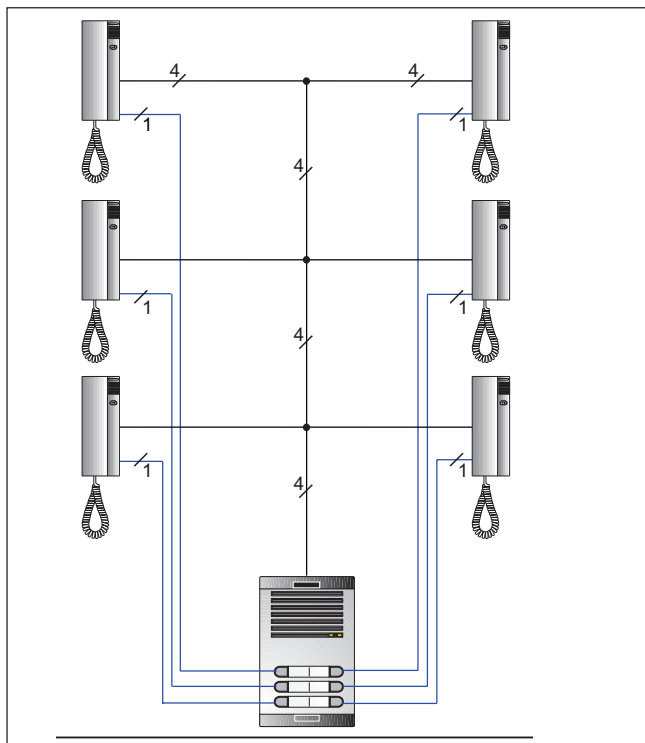

VDS Video Door Entry System
 5 «Digital Call» wires
 L: Data and Audio
 +,-: Power Supply
 V, M: Video

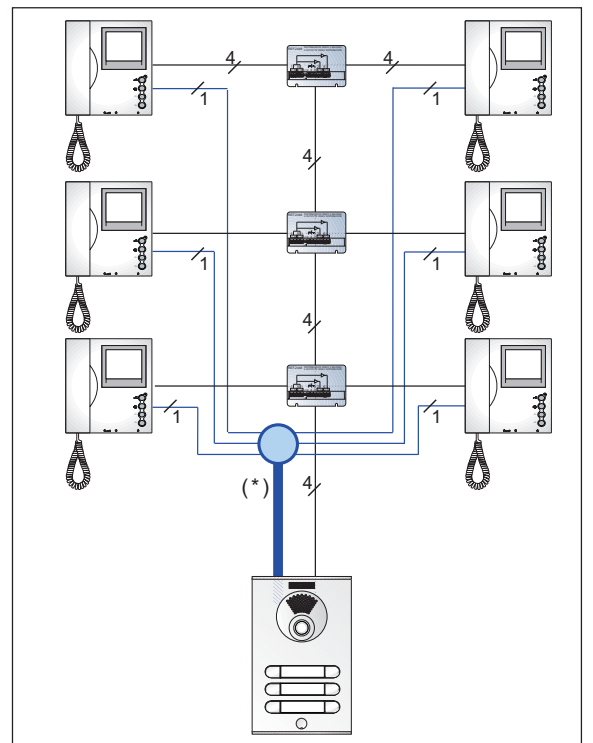

(*) The «call routing» wires are used as a common negative wire on the system.

NOTE: For **replacement systems**, it is recommended that the user carries out a prior evaluation of the wiring features so as to be aware of the relevant characteristics and determine if any replacement or reorganisation is necessary.

For more information please refer to the section on: «The VDS system in REPLACEMENT Installations» in the relevant manual.

VDS System Operating Principles

The VDS door entry/video door entry system functions like a large, single-line kit. Calls from the entry panel are routed via the «L» data line to the residential terminal, establishing a communication channel between the entry panel and said terminal.

Every apartment terminal (telephone/monitor) is programmed using an address which identifies it within the system and distinguishes it from the other terminals. The addresses range from 1 to 199 (terminal programming is explained in the corresponding section for each terminal).

*** Call:**

When a call is made from the outdoor entry panel to a residence, the panel's integrated amplifier generates the corresponding «VDS call code/address» and sends it via the data bus.

The way in which the call is made and the call code generated depends on the type of entry panel:

- **Button Panels (City):** In the case of the button panels, each button corresponds to a particular «VDS call code/address» which means that a call can be made to a residence by pressing the corresponding call button.

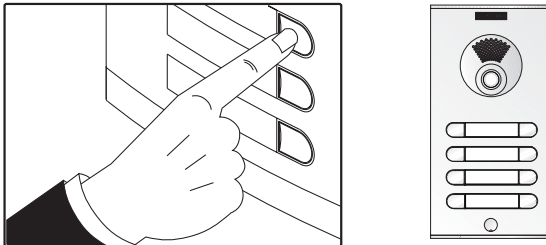

- **Keypad Panels (Direct):** The call to the residence is made by entering the «VDS call code/address» allocated to each residential terminal on the numerical keypad, which also has an access control function.

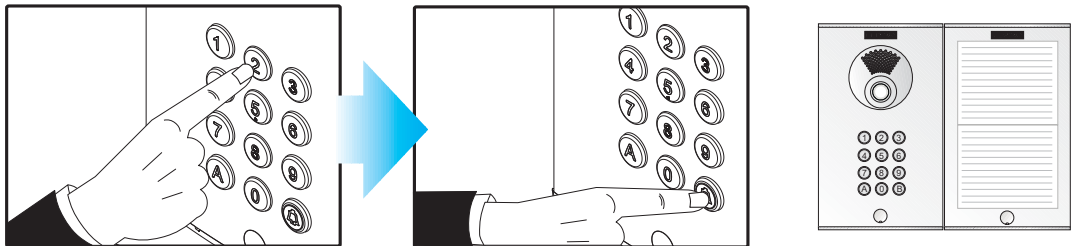

- **Panels with a keypad and electronic directory (digital):** The call to the residence is made using the numerical keypad (which also has an access control function) which enters the «VDS call code/address» allocated to each residential terminal. Alternatively, a call code can be entered (a number, generally the door number) which is associated with a specific address pre-programmed on the panel.

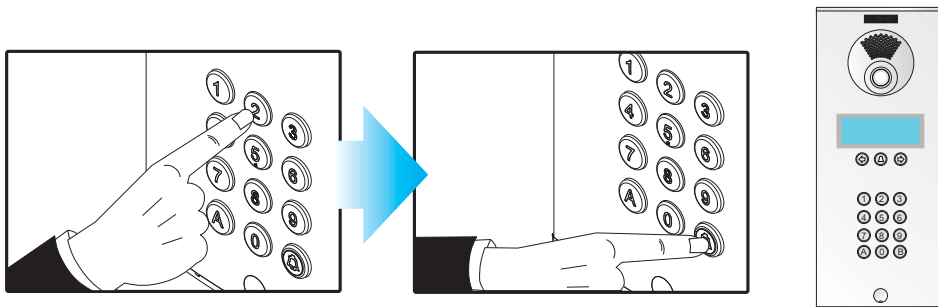

The digital panels feature an electronic directory which can be used to search for numbers on an LCD display and call the corresponding residence directly by pressing the button «bell».



Call Reception

The call code sent via the (L) data line is received by all system terminals, but is only recognised by the residential terminal (or terminals) programmed with the same code. A call tone is generated within the residence and the video function is activated (on video terminals).

Communication and Door Opening

When the residential terminal receives a call (its address coincides with the call code generated by the amplifier), a direct connection is established between the terminal called and the panel/reception making the call, via a single communication path without branching.

Upon picking up the terminal, audio/video communication is established between the terminal and panel/reception.

This communication is limited to a maximum time period of 90 seconds (if this is exceeded, communication will be cut off) and a minimum time of 15 seconds (during which no call requests from other panels or autostart from other terminals can be made).

Communication can also be established with the outdoor entry panel without any call being made, through the autostart function available on all video terminals (please consult the 'residential terminals' section).

During communication, the door can be opened by pressing the corresponding button on the residential terminal.

End of Communication: Terminating Call

Once the maximum communication time is reached, or upon hanging up the residential terminal, the system returns to its standby status: panel/guard unit on standby and terminals listening to bus.

Activation Commands

VDS system terminals include F1 and F2 buttons (present on all «Extra» monitor and telephone models) which allow the user to activate external devices (relays, timers, etc...) to control additional functions: courtesy lighting, secondary doors, garages, etc.

Installation and Start-Up Instructions for VDS systems

The installation and start-up steps for VDS systems are detailed below:

1.- Install and wire equipment.

Install and connect the equipment as indicated in the installation and wiring diagrams within this technical manual or other technical documentation supplied with each piece of equipment.

- Basic equipment to be installed:
 - Panels.
 - Guard Unit
 - Panel Switcher/Guard Unit: if 2 panels or a panel(s) + a guard unit exist.
 - Power Supplies (size depending on the number of terminals in the system).
 - Floor Level Distributors
 - Residential Terminals: telephone and monitors

For replacement systems, it is recommended that the user carries out a prior evaluation of the wiring features so as to be aware of the relevant features and determine if any replacement or reorganisation is necessary.

For more information please refer to the section entitled: «The VDS system in REPLACEMENT Installations» in the relevant manual.

2.- Configure outdoor entry panels.

If two outdoor entry panels exist, one of them must be configured as the main panel and the other as a secondary panel in order to differentiate between them. The panels have a configuration switch for this purpose (refer to the 'VDS Panels' section).

If only one outdoor entry panel exists, this should be configured as the main panel (default configuration).

3.- Programme residential terminals (telephones/monitors)

This involves assigning each residential terminal a call code/button to identify and distinguish it from the other terminals within the system.

The terminals are programmed from the outdoor entry panel which has been configured as the Main Panel (or from the guard unit where one exists).

4.- Execute final adjustments

Execute final installation adjustments:

- Adjust audio power in the residence-entry panel, entry panel-residence direction.
- Panel's Camera Orientation
- Lock-Release Time, etc.

Technical features to consider









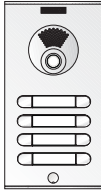
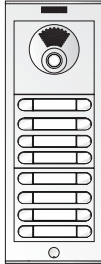
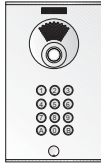
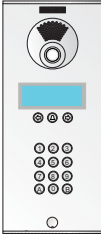
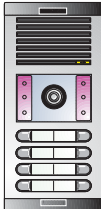
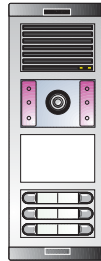

VDS System Parameters	Maximum Quantity
Panels	2
Guard Units	1
Total Terminals (telephones/monitors)	199

Distances:			
Audio			
metros / metres	pies / feet	mm ²	
1 - 50	3 - 150	1	
50 - 100	150 - 300	1,5	
100 - 200	300 - 600	2,5	
Video (up to 100m): UTP Cat5 / 5 wires			
metros / metres	pies / feet	mm ²	AWG
1 - 50	3 - 150	1	17
50 - 100	150 - 300	1,5	15
UTP CAT5			
Video (up to 200m): 3 wires + coaxial			
metros / metres	pies / feet	mm ²	AWG
1 - 50	3 - 150	1	17
50 - 100	150 - 300	1,5	15
100 - 200	300 - 600	2,5	13
			75 Ohm

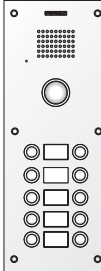
VDS PANELS

The VDS audio and video panels are available in the following designs and formats:

- Designs: Cityline (continuous profile), Citymax (modular), Halo, Marine and Bruto
- Types: City (buttons), Direct (keypad) and Digital (keypad+electronic directory).

	BUTTONS	MODULAR	DIRECT	DIGITAL
NEW CITYLINE				
CITYLINE				
HALO	 (*)	<i>Modular not available in Halo design.</i>	<i>Direct not available in Halo design.</i>	
MARINE		<i>Modular not available in Marine design.</i>	<i>Direct not available in Marine design.</i>	
BRUTO	 (*)			

(*): The continuous profile Halo and Bruto panels are only available in 1 line kits.

Guide to Existing Panel Designs. Consult panel availability in the desired design and format: new cityline, cityline, marine, bruto, audio, video, x buttons, direct, digital, etc..

VDS Panels. -«VDS Amplifiers»

All VDS panels (City, Direct, Digital) have a VDS amplifier which manages all system functions (calls, two way communication, door opening, programming, etc.).

There are 3 VDS amplifier models depending on the panel design. Irrespective of the model, all VDS amplifiers are compatible, they have the same functions and features and therefore any of the VDS amplifier models can co-exist in the same system.

New Cityline Panels

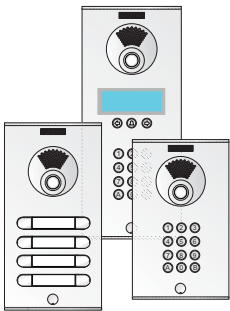

City, Direct and Digital

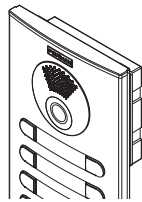

Amplifier Video



Amplifier Audio

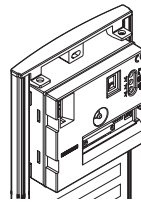

Amplifier rear view

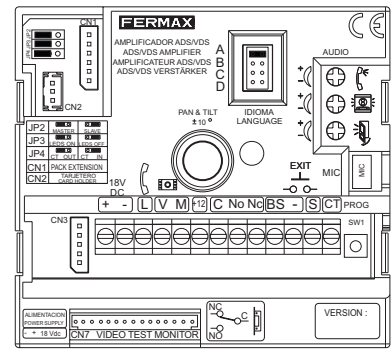

Cityline, Marine and Bruto Panels

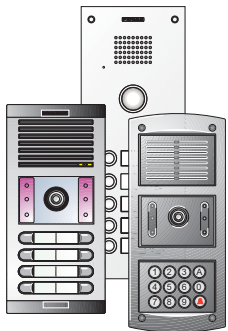

City, Direct and Digital

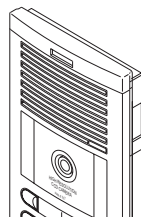

Amplifier

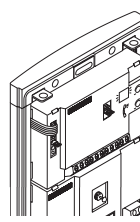

Amplifier rear view

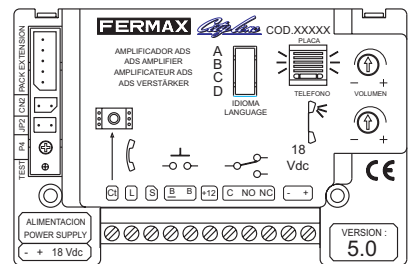

Halo Panels

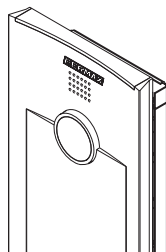

Amplifier

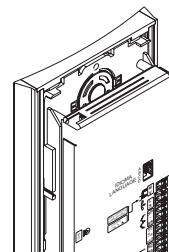

Amplifier rear view

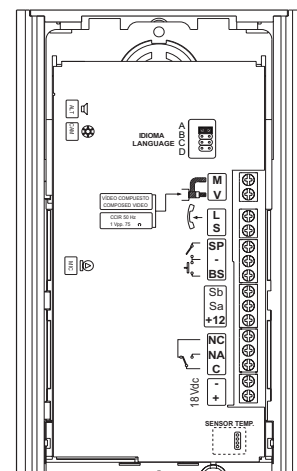

The Halo Panel and the integrated VDS amplifier in contrast with all other panel versions form a single block which cannot be separated from the rest of the panel's electronics.

The main features of VDS amplifiers, common to all models are the following:

*** Voice Synthesiser**

Every amplifier is fitted with a voice synthesiser module, which transmits the message ‘ Door open, please close after entering’ every time the lock-release command is activated from a residence.

The message language can be configured: Default languages are French, English, Spanish and German, depending on the position of the message selection switch, or can be cancelled if the switch is not set in any of the positions.

The synthesiser module can be replaced by other versions which include other languages (Valencian, Catalan, Portuguese, Polish, Dutch, Russian, etc.). For more information, please consult technical manual code 94335b.

*** Programming Lock-Release Times**

The lock-release time can be programmed at between 1 and 99 seconds.

*** For systems with one or two access points.**

In systems with two access points, one of the panels must be defined as the MAIN ACCESS (in diagrams shown with ‘1’), with the other defined as the SECONDARY ACCESS (in diagrams shown with ‘2’), using a switch (JP2) located in the panel amplifier.

System programming must always be carried out from the ACCESS 1 panel, that is, from the one on which this switch remains on. See installation diagrams.

*** Potential-free relay (C, NO, NC): continuous or alternating lock-release activation.**

The VDS amplifier is fitted with a potential-free relay which enables continuous (12Vdc, 0.5A) or alternating (12Vac, max 4A) lock-release connection.

*** Automatic Protection against faulty wiring.**

The VDS amplifier incorporates electronic circuits for protection against faulty system wiring, in each case presenting the relevant warning signs as explained in the TABLE OF INCIDENTS AND SOLUTIONS, (at the end of this manual).

SHORT CIRCUIT between wires:	SYMPTOMS PROVOKED:
«+» (positive) and «-» (negative)	<ul style="list-style-type: none"> • Nothing works • When making a call nothing happens. • The short circuit causes the power supply’s protection devices to be activated such that there is no current between «+» and «-».
«-» (negative) and «L» (audio-data)	<ul style="list-style-type: none"> • The panel will emit constant beeps (acoustic connection) or a series of short beeps.
«+» (positive) and «L» (audio-data)	<ul style="list-style-type: none"> • Despite there being a 18 Vdc current between «+» and «-» nothing will work. • There is no call, but there is panel monitoring. • When you press the call button, the Diagnostic LED emits a number of short flashes.

Developments in the VDS amplifier for New Cityline Panels:

*** Camera integrated into the video amplifier**

The video amplifiers have one single electronic unit which incorporates the camera and its adjustment features (pan&tilt, camera lighting leds).

This feature allows a entry panel to be immediately replaced with a video door entry system using the same flush mounted box and maintaining the same dimensions.

*** Microphone in lower section of panel**

The new Cityline panels incorporate the microphone into the lower section of the panel, away from the speaker (located in the amplifier) improving the audio quality (avoiding possible overlap and reverberations).

*** Mapping Function**

In button panels, the mapping function enables advanced programming of call code button combinations alternative to the standard assignation (see the ‘Advanced Programming’ section. Mapping »):

*** Programming Lock-Release Times**

You can programme the lock-release time at between 1 and 99 seconds in button panels without the need for additional keys. (see the ‘Advanced Programming’ section). Lock Release Times.

*** Restore default values**

The VDS amplifier has a ‘Reset’ function which can be used to restore programmed default parameters (door and entrance hall lock-release times, access codes, mapping) (see the «VDS Amplifier - Reset» section).

VDS Amplifier - New Cityline Panels

The VDS amplifier manages all the VDS system functions: calls, two-way communication, door opening, programming.... It is available in Audio and Video versions.

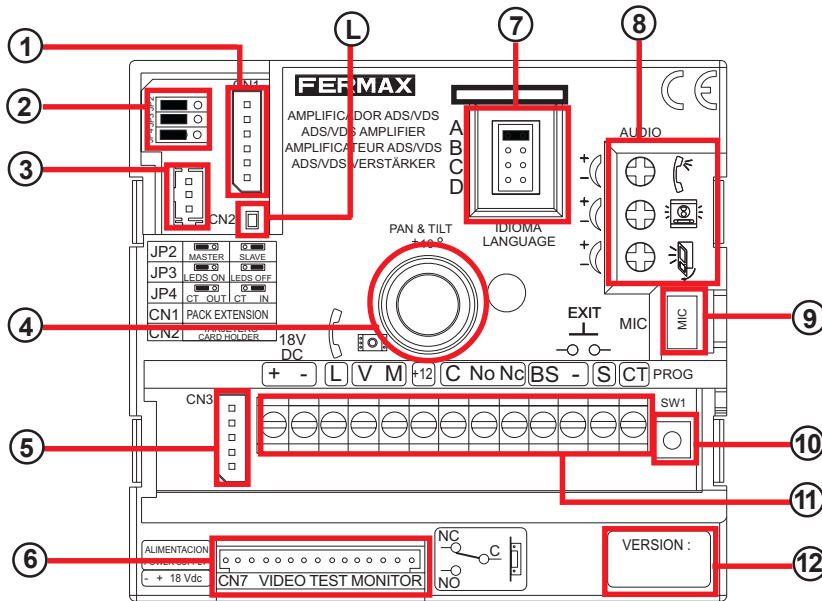

- ① **CN1:** Connection for call extension module, keypad, display or up to three buttons (the same amplifier for buildings and kits with up to 3 lines).

CN1 Detail:

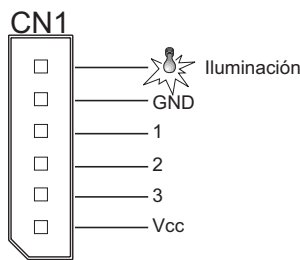

- ② **Configuration Switches:**

	■ ○	○ ■
JP2 : Main/Secondary Panel Selection Switch	Main Panel	Secondary Panel
JP3: Camera LEDs (video amplifier)	Leds ON	Leds OFF
JP4: CT: Camera activation/auxiliary output	CT: 11 Vdc output	CT: entrance. Connect 12 Vdc to activate camera + leds permanently

- ③ **CN2:** "L+, L-": Button and card holder illumination connection. **Door Controller** Common Button Wire
- ④ **Remote camera** with 10° Pan&Tilt adjustment function (video amplifier).
- ⑤ **CN3:** Status LED connection. Very useful for disabled people, allowing leds to be connected which provide information on communication status.



Depending on the action executed, the corresponding LED is activated):



L2, L3, L4: give a negative result when the corresponding action is executed, thus activating the LED connected between Lx and +.

- ⑥ **CN7. Video Test Monitor:** Monitor Programming and Test Connector
- ⑦ **Voice synthesiser:** 'Door open' language selection.

⑧ **Controls for audio adjustments:**

-  Audio volume adjustment in entry panel - residence direction.
-  Audio volume adjustment in residence-entry panel direction.
-  Volume adjustment for *call monitoring* and *voice synthesis*.

⑨ **MIC:** Microphone connections (microphone is located in the interior panel profile).

⑩ **SW1 Mapping:** button to enter switch programming mode (see the Advanced Programming - Mapping section).

⑫ **Connection Terminals:**

+, **-** 18Vdc power supply.

L: audio + data bus

V, M: video terminals: V: live; M: mesh (only in video amplifier).

+12: Auxiliary voltage output (12Vdc, 0.4A max).

C, NO, NC: Potential-free door lock-release relay (4A). Activates alternating lock release (if the system is equipped with this source), magnetic locks, signals to other devices, etc.

BS, -: Button connection to open door from inside the entrance hall.

S: Activation signal which gives a negative result when the panel is activated after a call or autostart.

CT: Camera activation signal or auxiliary output (11 Vdc). Configurable using the JP4 switch.

⑪ Amplifier Version.

Ⓛ **Diagnostic Led:** If there is a short circuit between “L” and “+”, short flashes will be emitted when a call is made from the panel.

*** Restore factory settings. Reset**

The VDS amplifier has a 'Reset' function which can be used to restore programmed default parameters (door and hall lock-release times, access codes, mapping).

- Reset from button panels

To restore the default values, follow the steps below:

- 1.- Reset amplifier: disconnect power supply
- 2.- Press the SW1 button, connect power supply and keep SW1 button pressed until you hear the reset confirmation sound.

- Reset from keypad panels

To restore the default values, follow the steps below:

- 1.- Reset amplifier: disconnect power supply
- 2.- Connect power supply and within the first 60 seconds, enter the code A708B9. After entering the code, a prolonged beep will sound to confirm the restoration of default values.

*** Technical Features**

Power Supply		18 Vdc
Consumption:	on standby	57 mA
	active audio	300 mA
	audio + video	380 mA
Operating Temperature		-10, +60 °C
Maximum audio power in the residence -entry panel direction		2 W
Maximum audio power in the entry panel - residence direction.		0.15 W

VDS Amplifier - Cityline, Marine and Bruto Panels

The VDS amplifier manages all the VDS system functions: calls, two-way communication, door opening, programming....

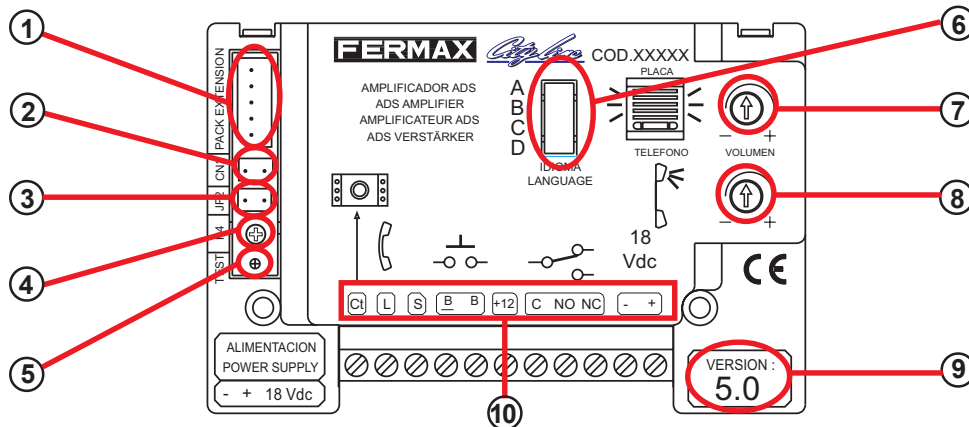

- ① Connection for call extension module, keypad, display or up to three buttons (the same amplifier for buildings and kits with up to 3 lines).
- ② **CN2**: Button and card holder illumination connection.
- ③ **JP2** : Main/Secondary Panel Selection Switch:
Main Panel: leave switch in place.
Secondary Panel: remove switch.
- ④ **P4**: Potentiometer for volume adjustment as part of *call monitoring* and *voice synthesis*.
- ⑤ Test Led (Diagnostic): If there is a short circuit between “L” and “+”, short flashes will be emitted when a call is made from the panel.
- ⑥ **Voice Synthesiser**: ‘Door Open’ language selection.
- ⑦ Potentiometer for volume adjustments in the residence - entry panel direction.
- ⑧ Potentiometer for volume adjustments in the entry panel - residence direction.
- ⑨ Amplifier Version.
- ⑩ Connection Terminals:
Ct: Camera Activation (10 Vdc).
L: Audio + Data Bus.
S: Activation signal which gives a negative result when the panel is activated after a call or when auto-started.
B, B: Button connection to open door from inside the entrance hall.
+12: Auxiliary voltage output (12Vdc, 0.4A max).
C, NO, NC: Potential-free door lock-release relay (4A). Activates the alternating lock release (if the system is equipped with this source), magnetic locks, signals to other devices, etc.
+, -: 18 Vdc power supply.

Technical Features

Power Supply		18 Vdc
Consumption	on standby	40 mA
	active audio	250 mA
Operating Temperature		-10 , +60 °C
Maximum audio power in the residence -entry panel direction		1 W
Maximum audio power in the entry panel - residence direction		0.15 W

VDS Amplifier - Halo Panels

The VDS amplifier manages all the VDS system functions: calls, two-way communication, door opening, programming....

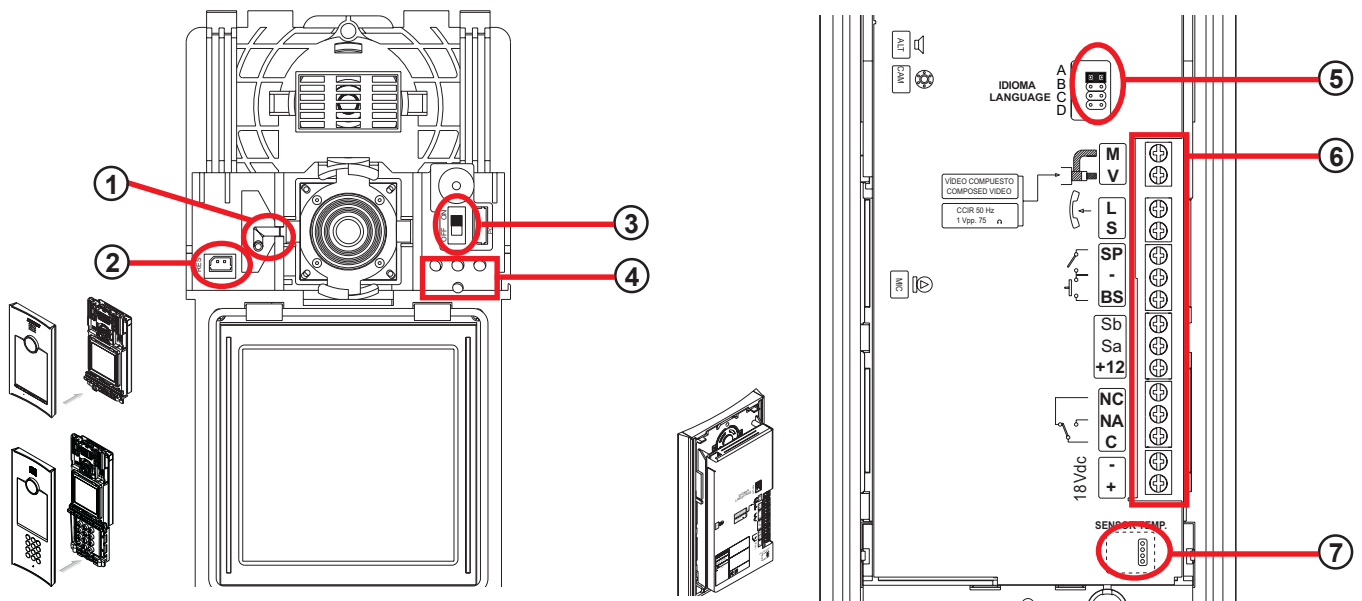

- ① Pan & Tilt Camera Adjustment (10° horizontal - vertical).
- ② Heat Resistant Connector (optional).
- ③ Camera Lighting Deactivation/Activation Switch
- ④ Adjustment Potentiometers:

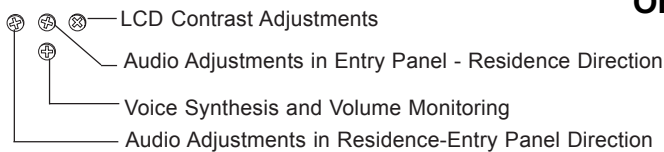

ON The camera leds are activated when a call is made from the panel or auto-started from the residence. (Default Mode).
OFF: The leds are never activated.

- ⑤ **Voice Synthesiser**: 'Door Open' language selection.
- ⑥ Connection Terminals:

V,M: Video Terminals (V: live, M: mesh).

Ct: Camera Activation (10 Vdc).

L: Audio + Data Bus.

S: Activation signal which gives a negative result when the panel is activated after a call or when auto-started. .

BS, -: Button connection to open door from inside the entrance hall.

SP, -: Open-Door Sensor Connection.

Sa, Sb: PC Connection and Panel Cloning.

+12: Auxiliary voltage output (12Vdc, 0.4A max).

NC, NO, C : Potential-free door lock release relay (4A). Activates alternating lock release (if the system is equipped with this source), magnetic locks, signals to other devices, etc.

+,-: 18 Vdc Power Supply

- ⑦ Temperature Sensor Connector.

Technical Features

Power Supply Consumption	On Standby + Backlight Off	18 Vdc
	with call + backlight on	200 mA
	call	370 mA
	active audio	50 mA (additional)
	active voice synthesis	60 mA (additional)
	keypad lit-up (building panel)	140 mA (additional)
	keypad lit-up (building panel)	50 mA (additional)
Operating Temperature		-10, +60 °C
Maximum audio power in the residence -entry panel		1 W
Maximum audio power in the entry panel - residence direction		0.15 W
Real Time Clock (RTC). Stability ± 20 ppm		

VDS NEW CITYLINE PANELS

CITY VDS continuous profile panels

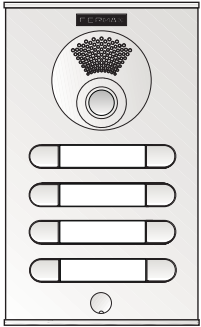

The City VDS panels are characterised by their:

- **VDS Amplifier Module:** a module which manages all VDS system functions: calls, two-way communication, door opening, programming....
In video panels, the amplifier module is equipped with a remote camera (B/W and Colour), in addition to the amplifier electronics.
- **Call Buttons:** Calls to apartments are made by pressing the corresponding call button assigned to the residence.
- **Call Extension Module** (one for every 16 buttons): The main advantage of a VDS panel is that it does not use call wires. This is possible because the call is made through the transmission of a digital code, which is generated via *call extension modules* (see the 'Call Extension Module' section). This module is not necessary if the panel has 1 to 3 buttons.
- **Programming Lock-Release Time** between 1 and 99 seconds (see the 'Advanced Programming - Lock-Release Times' section).

* CITY VDS Panel Type

Aesthetically, the CITY panels are classified into **9 series**, all of which are the same width, but different heights.

The new range of CITY panels enables installation around the same model of audio or video amplifier due to the fact that the remote camera is built into the video amplifier module.

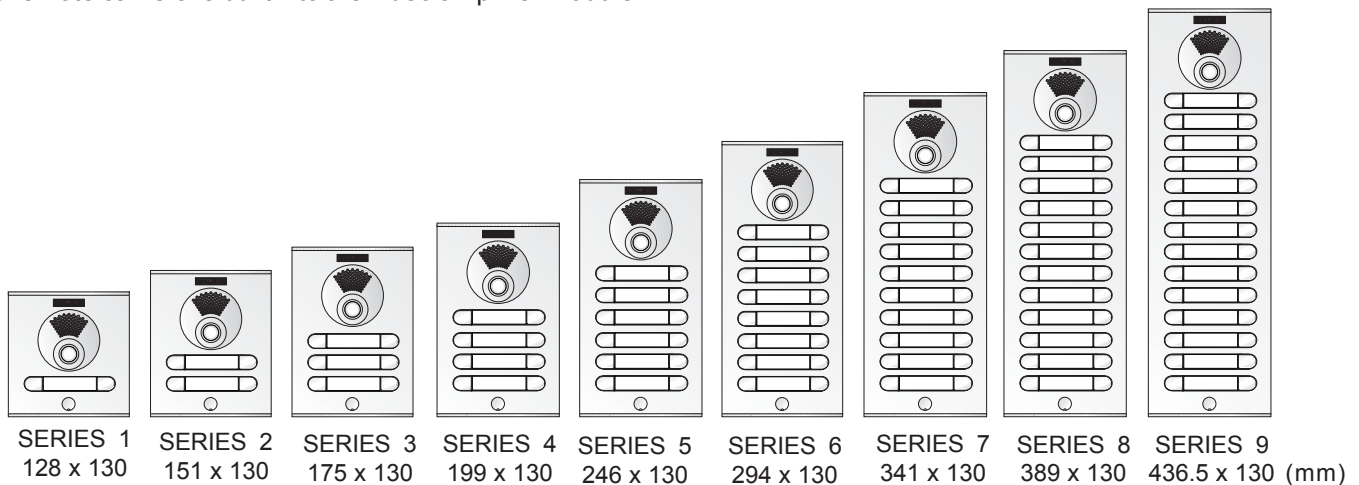

The CITY panels enable a range of combinations (audio, video amplifier, with single or double button, with recess). This permits a selection to be made to fit the characteristics of each individual system (number of residences, door entry system or video door entry system, etc.):

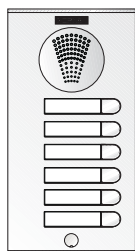

Panel with audio amplifier and single buttons.

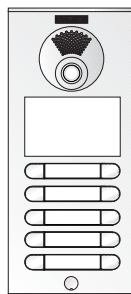

Panel with video amplifier, recess and double buttons.

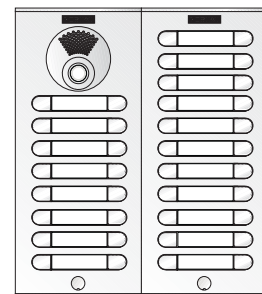

Panel 1 with video amplifier and double buttons.
Panel 2 without amplifier and with double buttons.

Additional function modules: a range of different modules (optional) exist, which can be installed in the outdoor entry panel to provide the system with additional functions to increase the system resources: proximity card reader, bluetooth for access control, etc.

*** Call extension module, Ref. 2441**

One of the advantages of the VDS system is that no call wires are used. This is possible because the call is made through the transmission of a digital code generated by the amplifier in the outdoor entry panel when a specific call button is pressed.

This code is sent via the «L» data wire to all system's residential terminals (monitors/telephones). Only a terminal previously programmed with the relevant code will recognise it and generate a call tone.

Obviously, after setting up the system, it will be necessary to programme each one of the monitors or phones with its corresponding call code. This is very simple to do, as explained in the «VDS Terminals» section.

Call extension modules are used in button panels to generate the specific code for each call (one for every 16 buttons). This module translates each button press on the panel into a call code. (See connection diagrams for the call extension module).

City panels with 1 to 3 buttons do not require the installation of a call extension module (see panel pre-wiring diagrams).

Call extension module connection on City VDS panels

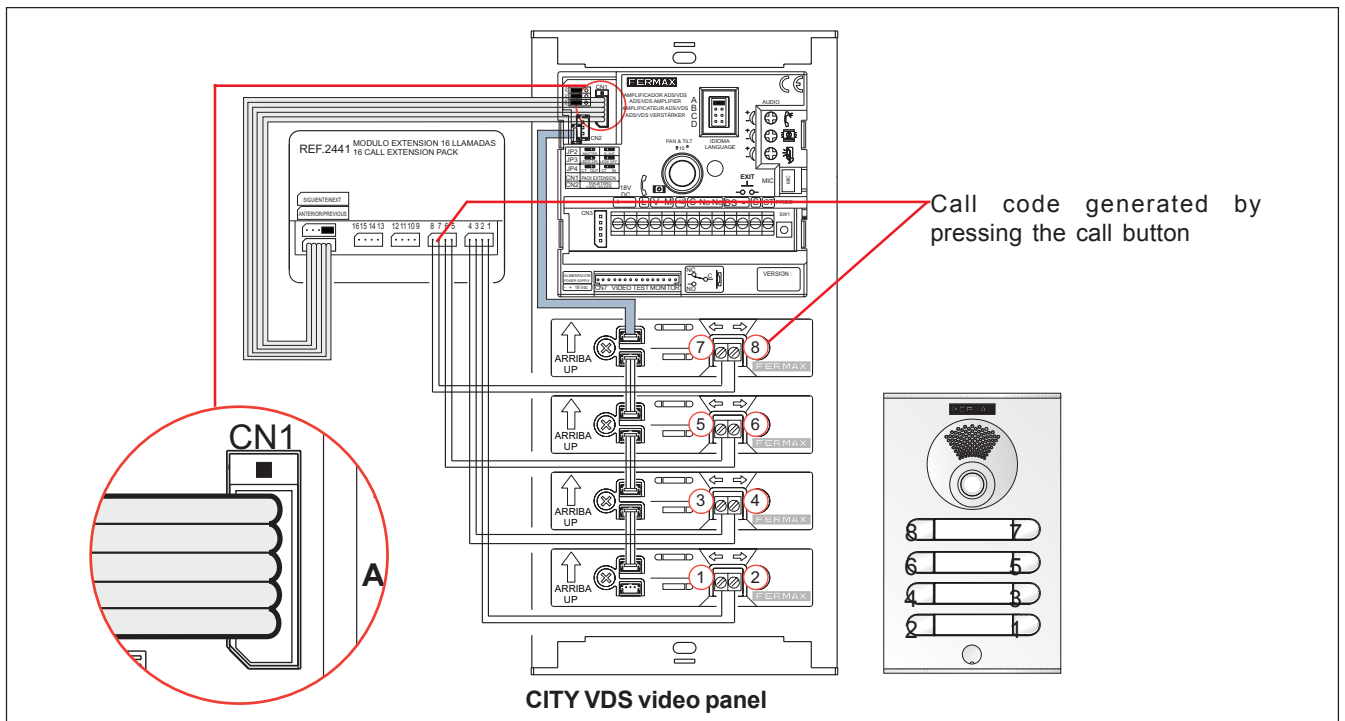

If a larger number of buttons need to be covered, two or more modules can be used, up to the maximum of 199 residences allowed by the VDS system.

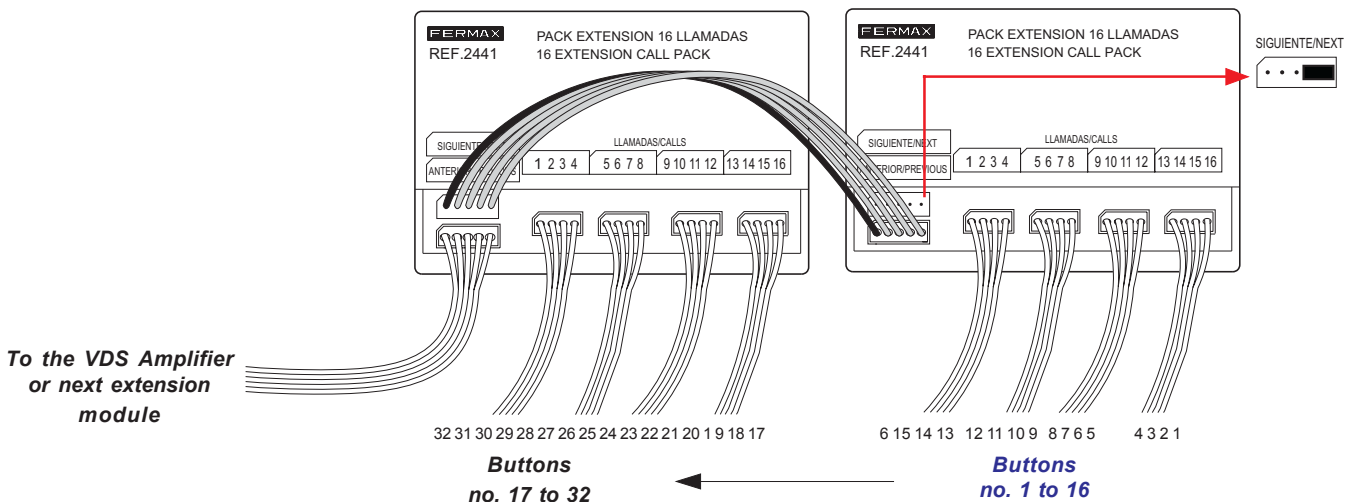

The assignation of call codes as carried out by the call extension module can be modified by using the 'Mapping' function available on the VDS amplifier. See the 'Advanced Programming - Mapping' section).

Modular CITY VDS panels

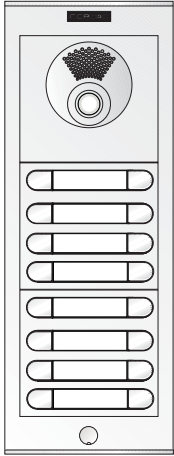

The VDS modular panels comprise the FERMAX range of continuous profile and modular composition entry panels. The modular panels are characterised by their:

- **VDS Amplifier Module:** a module which manages all VDS system functions: calls, two-way communication, door opening, programming....
It is available in audio and video (b/w and colour) versions.
The amplifier module can have 1 or 2 buttons.
- **Button Modules:** With these modules, no call extension module is necessary. The button modules generate the call code. The button modules are available with 2, 4 and 8 buttons.
Calls to residences are made by pressing the corresponding call button assigned to the residence.
- **Display Module and Direct Keypad:** Allows the construction of Direct and Digital VDS modular panels.
- **Additional function modules:** a range of different modules (optional) exist, which can be installed in the outdoor entry panel to provide the system with additional functions to increase the system resources: keypad modules, proximity card reader, bluetooth for access control, etc.
- **Programming Lock-Release Time** between 1 and 99 seconds (see the «Advanced Programming - Lock-Release Times» section).

Another cutting-edge characteristic of the new City panels is the possibility of combining button, keypad and display modules in one panel.

* **BUS2 Modular Panel Type**

The panel's assembly is very easy. Simply select the module combination, fit them in the frames and connect them together using the connection cables:

<p>Modular Panels</p> <p>Required for the insertion of modules: amplifier, buttons, keypad, etc.</p> <p>The panel models are the same as CityLine panel series 2,4, 5, 6 and 7.</p>	
<p>Amplifier Modules</p> <p>Audio or video (b/w and colour), with or without integrated buttons.</p> <p>Includes a connection cable to the first button module.</p>	<p>Audio </p> <p>Video </p>
<p>Button Modules</p> <p>With these modules, no call extension module is necessary, which significantly reduces the cost of the system. An interconnection cable to the next module is provided.</p>	<p>Single </p> <p>Double </p>
<p>Display module and direct keypad</p> <p>These modules enable the construction of VDS Digital and Direct panels, which can also be combined with the 1-2 button amplifier modules and button modules.</p>	<p>Display </p> <p>Direct </p>
<p>Additional function modules</p> <p>1- Cardholder 2- Blind Modules 3- Memokey Keypad (*)</p> <p>4- Fingerprint Reader (*) 5- Bluetooth Reader (*) 6- Proximity Reader (*)</p> <p>(*) Autonomous Access Control</p>	

*** Interconnection of Button Modules**

As mentioned above, the modular panels do not require a call extension module, given that the button modules generate the «VDS call code» corresponding to each residence (do not confuse the VDS call code or VDS call address with the residence door no.).

The different button modules interconnect amongst themselves to form the required panel configuration:

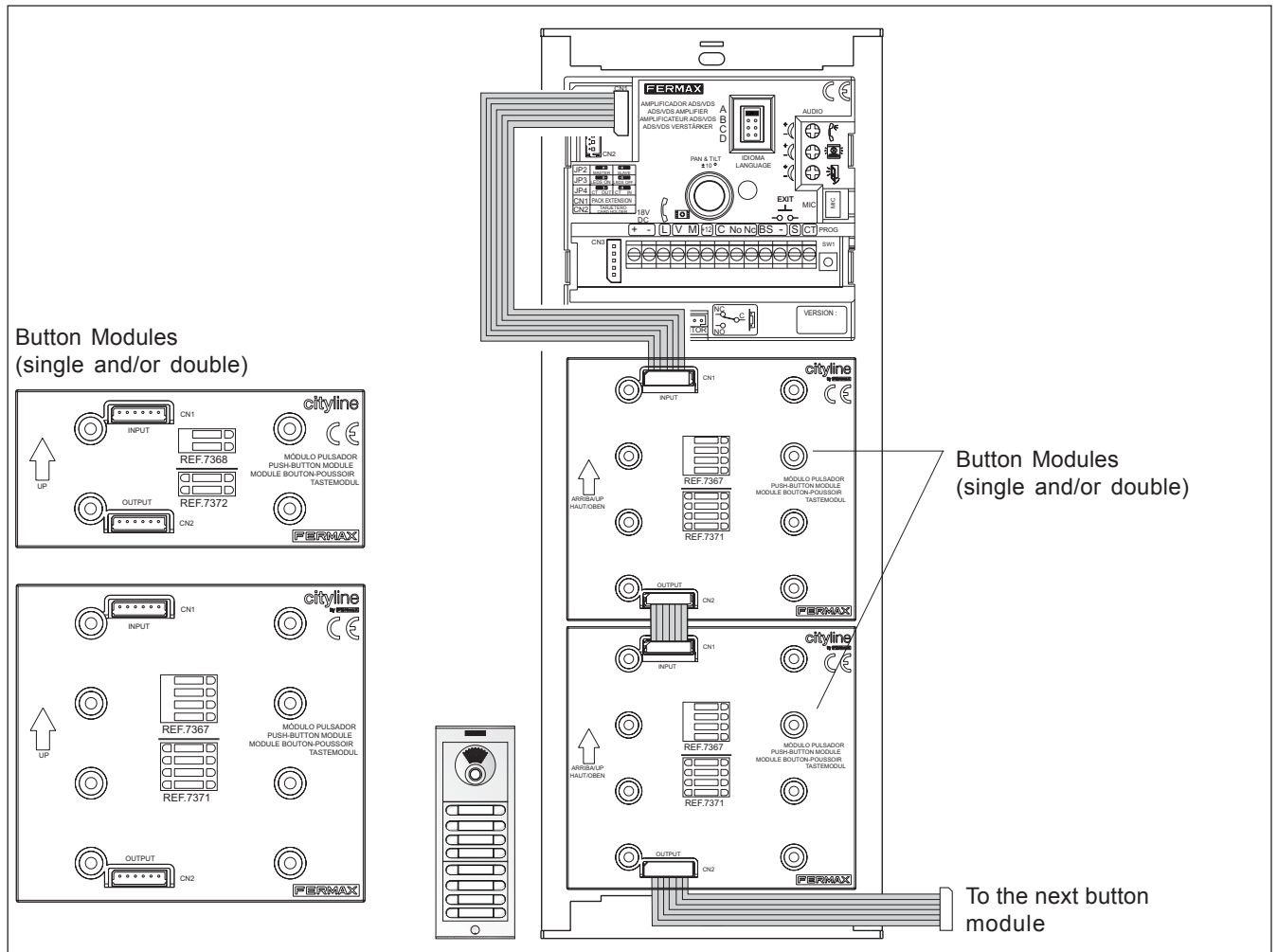

VDS addresses (call codes)

The VDS amplifier automatically assigns the call codes to the connected module's buttons. Regardless of the button structure in place, the amplifier will list the buttons from bottom to top and from right to left (in the case of double buttons):

*** Examples:**

VDS Addresses assigned to each button by the amplifier:

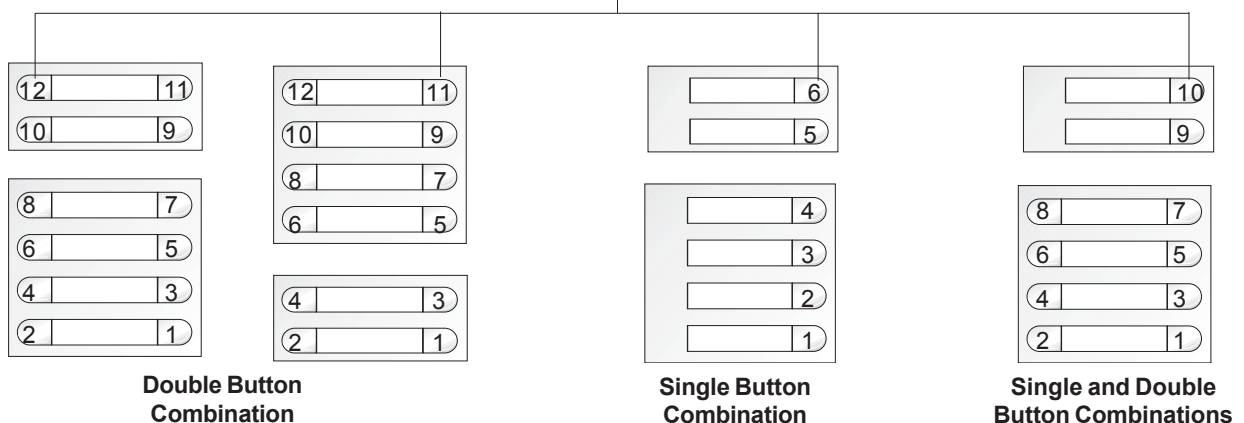

The automatic assignment of call codes as done by the amplifier can be modified using the 'Mapping' function available on the VDS amplifier. See the 'Advanced Programming - Mapping' section).

DIRECT VDS PANELS

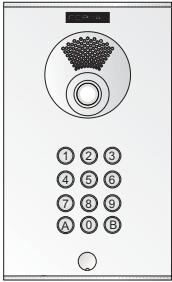

The DIRECT VDS panels are characterised by their:

- **VDS Amplifier Module:** a module which manages all VDS system functions: calls, two-way communication, door opening, programming....

It is available in audio and video (b/w and colour) versions.

- **Numerical Keypad:** The keypad will generate the call code to the residence, call extension modules are not necessary.

Calls to residences are made by pressing the corresponding code assigned to the residence.

- **Access Control:** Via the numerical keypad, the Direct systems incorporate access control functions using keypad codes (previously programmed).

- **Programming the lock-release time** between 1 and 99 seconds.

*** DIRECT VDS panel typology**

The size of VDS DIRECT panels is always the same (Series 4 or 6 if a recess is included) independently of the number of residences.

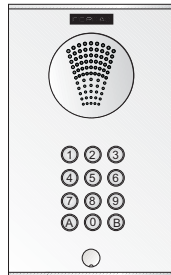

DIRECT AUDIO Panel

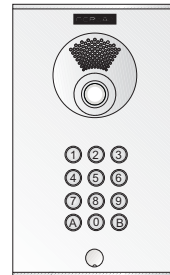

DIRECT VIDEOPanel

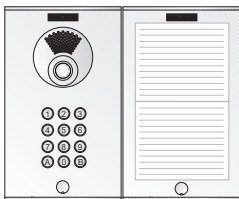

In addition to the DIRECT panels, a DIRECTORY PANEL can be installed (same series), in the aim of saving a corresponding name with each of the residential codes.

The directory panel is fitted with a lighting leds which must be connected to the VDS amplifier (see internal panel wiring diagrams).

It is also possible to construct **DIRECT modular** panels and combine them with button modules:

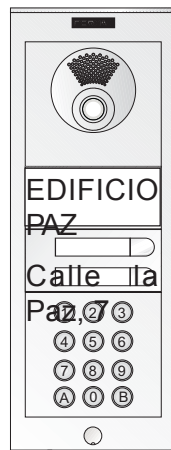

DIRECT MODULAR panel with buttons

Programming the lock-release code on Direct Panels

All Direct panel models enable the door to be opened from the outdoor entry panel by entering a 4-digit code.

The steps to be followed to activate and configure the door lock release using a code are detailed below:

**** Door lock-release activation sequence.***

- 1.- With the power supply disconnected, execute a short circuit between the «Bs» and «-» amplifier terminals (negative) (or press the opening button if it is installed).
- 2.- Maintaining the short-circuit induced above, connect the system's power supply (at this point it will no longer be necessary to maintain the short circuit or hold down the button). You will have a time frame of 1 minute to activate the opening code as is described in the following point.
- 3.- Enter the programming code 3 1 4 1 (this code cannot be changed) and enter the four digit code you wish to use to open the door, followed by the  key.

**** Changing the code***

In order to be able to change the opening code, you must know the previous digit combination used. If the previous code is not known, the sequence described above cannot be carried out.

The code changing programming sequence is the following:

- 1.- Enter the programming code: 3 1 4 1.
- 2.- Enter the current door opening code.
- 3.- Enter the new code (four digits) and press the  key.

NOTES:

- Use key 'A' to delete or re-start the sequence.
- Do not forget to disengage the short circuit between «Bs» and «-» on the panel amplifier after carrying out the necessary tasks.
- Once the opening code has been activated, this function cannot be disabled. This means that an opening code will

Programming the door lock-release time on Direct Panels

All Direct panel models allow the lock-release times to be programmed.

**** There are two programmable activation times:***

- Door opening time from the residence and from the panel keypad (using the opening code).
- Opening time corresponding to button located inside the building which serves to activate the lock-release function (providing it has been installed).

**** The programming sequence is as follows:***

- 1.- Disconnect the power supply and then reconnect. A time frame of approximately 1 minute exists for the execution of the following sequence.
- 2.- Enter the programming code 3 1 4 1 followed by 4 digits and press the % key.

Of these 4 figures, the first two correspond to the opening time set from the residence and the last two to the opening time set from the button installed in the entrance hall.

NOTES:

- The possible times range between 1 and 99 seconds.
- Any time less than 10 seconds must be preceded by the digit '0'.
- In the case of an error during time programming (or if you wish to make any modifications) you must re-start the sequence from step 1.

DIGITAL VDS Panels

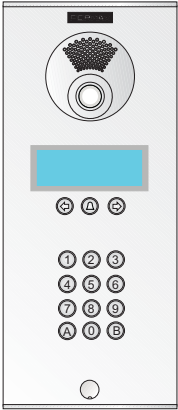

The Digital VDS panels are characterised by their:

- **VDS Amplifier Module:** a module which manages all BUS2 system functions: calls, two-way communication, door opening, programming....
It is available in audio and video (b/w and colour) versions.
- **LCD Display:** The Digital panels incorporate an **electronic directory** which allows the user to search for names (homeowners...) via the LCD screen.
Various system parameters can be programmed using the keypad and display.
- **Numerical Keypad:** The keypad will generate the call code to the residence, call extension modules are not necessary.
Calls to residences are made by pressing the corresponding code assigned to the residence.
- **Access Control:** In addition to the access control functions available using keypad codes entered on the numerical keypad, the Digital panels allow the user connect a secondary card reader module from the *digital panel's display*. The users and their card or key codes are stored and managed using the keypad and display.
- **Programming the lock-release time** between 1 and 99 seconds.

*** DIGITAL VDS Panel Typology**

The size of the DIGITAL panels is always the same, i.e. series 6, regardless of the number of residences.

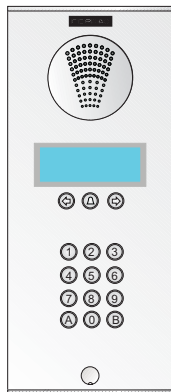

DIGITAL AUDIO Panel

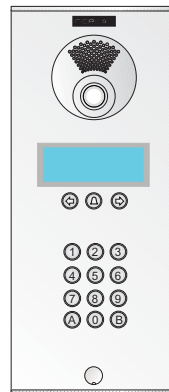

DIGITAL VIDEO Panel

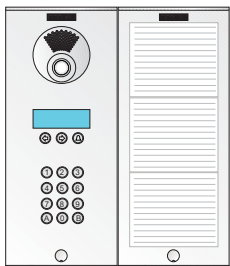

In addition to the DIGITAL panels, the DIRECTORY PANEL can be installed (same series), in the aim of saving the corresponding name for each of the residential codes. This Directory Panel is optional as its function is already provided by the LCD display.

The directory panel is fitted with a set of lamps which must be connected to the VDS amplifier (see internal panel wiring diagrams).

It is also possible to construct **DIGITAL modular** panels and combine them with button modules:

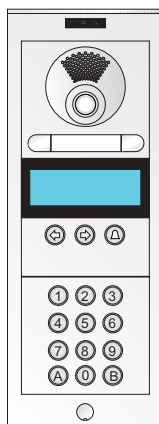

DIGITAL MODULAR panel with buttons

Parameter configuration in VDS Digital Panels

The Digital VDS Panels have added functions, which are programmed using the keypad and display:

- Electronic Directory:

Enables the user enter the details of up to 350 users (residents) (although there is a maximum of 199 residences). This way, various users can be registered for the same residence.

This function enables visitors to see the details of residents registered in the directory, thus simplifying the search process (via arrows) and call procedure (once the person has been found) by simply pressing the key .

- Personalised Opening Codes:

This enables every user to be allocated a personal code, proximity card or key button (the last two options are only available where there is a secondary proximity reader ref. 23352 or key button ref. 23362) in order to access the building.

- 4-digit call configuration:



The digital directory can also be used to establish 4-digit call codes (0001....9999), thus enabling the creation of 2-2 combinations (two digits for the floor and two for the apartment). This prevents the restriction of combinations to the VDS range (from 1 to 199).



- Programming and configuring door lock-release times.

Below is a quick guide to programming the basic VDS Digital panel parameters (for more information regarding programming, see the «VDS Direct-Digital NCity Panel Programming Manual ref. 97486»).

Programming user data

1.- Enter programming mode  + AB21AB + 24797

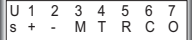
2.- User menu.....  

3.- Add users.....  

***Name:** 16 characters. This is shown on the first line of the display. If '*' is entered, this information will not be displayed.

***Line 2:** 16 characters. This is shown on the second line of the display and can be used to register more than one user per residence or to indicate the type of business.

***Line 2?:** press 'A' to allow the information entered in the corresponding field to appear on Line 2. Press 'B' to display the call code only ('DOOR: xxxx').

*** Call Code:** code from 0001 to 999 which must be entered by the visitor in order to call this user. This CANNOT be repeated. Press 'A' to correct. Validate by pressing 'B'.

*** Telephone code:** line number to which a call is made when the call code is entered or when a search is carried out on the screen and '%' is pressed. Like the rest of the VDS system, the line number must be a value between 001 and 199 and it must have been pre-programmed on the telephone/monitor. Press 'A' to correct. Validate by pressing 'B'.

*** Opening Code:** if using the keypad, the 6 digits must be entered. If fewer are used, the first 4 or 5 digits should be used, leaving out the numbers on the right. Press 'A' to correct. To validate, press 'B'.

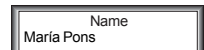
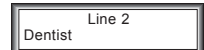



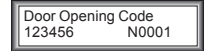





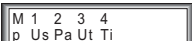

Programming the door lock-release code on Digital BUS2 panels

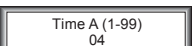
1.- Enter programming mode.....  + AB21AB + 24797

2.- Programming Menu for door lock-release times.....  

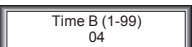
3.- Door opening times from residence (tO).....  
 This is the door lock-release activation time when the door opening command is activated from the residential terminal: telephone or monitor. A value between 1 and 99 seconds must be programmed. This is validated by pressing the 'B' key.

4.-Door opening times from panel.....  
 This parameter defines the time for which the door lock-release will be active once the door opening button connected to the panel is pressed, or when a valid user code is entered: on the keypad, or using the key button or proximity card. A value between 1 and 99 seconds must be programmed. This is validated by pressing the 'B' key.

VDS GUARD UNIT (Ref. 2536)

The VDS system can be completed with a desktop or wall-mounted CENTRAL GUARD UNIT.



The **VDS Central Guard Unit** offers a «filter» between a building’s visitors and its residents. This allows communication between the guard unit and the residences, as well as the reception of calls made from entry panels to the residences, so that they can then be transferred by the guard unit to the residence called or to an alternative residence.

The guard unit has 3 operational modes: Day, Automatic and Night.

VDS Guard Unit Connection Module (Ref. 2492)

To install a VDS guard unit in a system with entry panels you require a «VDS guard unit connection module» Ref. 2492.

This module allows the user select the active devices and establish communication between them:

- Guard Unit <--> Residential Terminals:
- Guard Unit <--> Panel.
- Panels <--> Residential Terminals:

In systems without an entry panel the installation of the guard unit does not require a connection module.

For more details see «Section II. Wiring Diagrams ».

VDS System with Guard Unit and Entry Panels

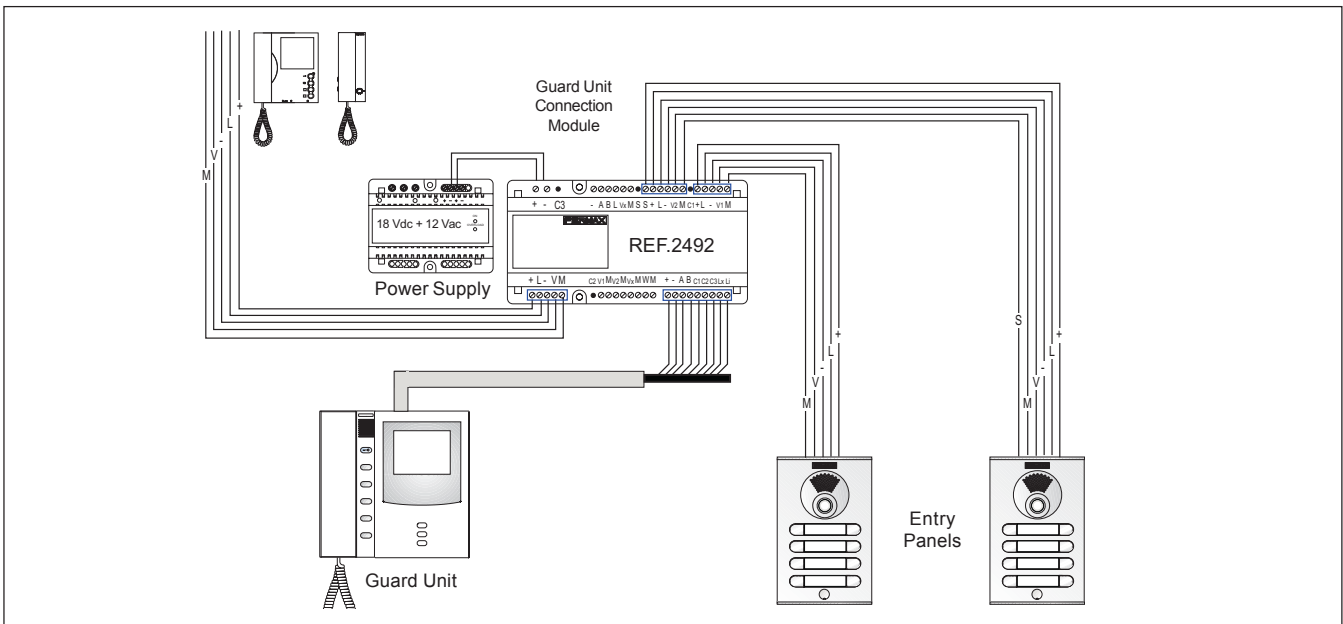

VDS System with Guard Unit but WITHOUT Entry Panels

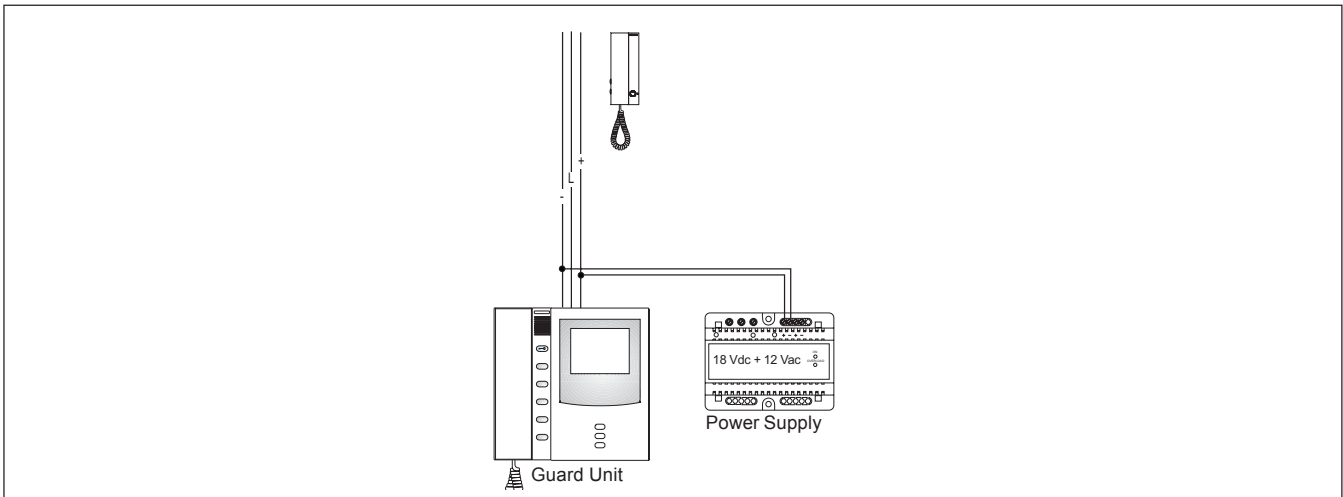

Description of Guard Unit Controls



Display

Offers a range of information when using the Central Guard Unit.

Call Queue Control Keys



Switch between panel and telephone call queues.



Cyclical selection of the call from the current queue (or panels or telephones).

Call (Bell)



To call residential telephones.



Lock-Releases

Door lock-release activation key.



Guard Communication - Telephone.

To select the GUARD UNIT - TELEPHONE communication channel. Communicate with the last telephone called.



Main Panel - Telephone Communication:

Activate the communication channel between the MAIN PANEL and the last TELEPHONE called.



Secondary Panel - Telephone Communication.

Activate the communication channel between the SECONDARY PANEL and the last TELEPHONE called.

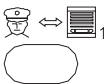

Guard Unit – Main Panel Communication.

Activate the communication channel between the GUARD UNIT and the MAIN PANEL.



Guard Unit - Secondary Panel Communication.

Activate the communication channel between the GUARD UNIT and the SECONDARY PANEL.

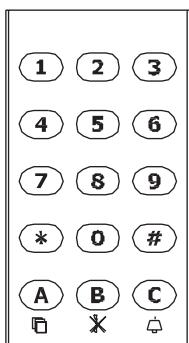

Keypad.

Located below the telephone receiver. Used to enter the telephone number for the residence to be called, panel number and all general data. It is also used to programme residential terminals as if it were a panel.



Activation/deactivation of call queue screen.

Used to activate or deactivate the option to view the call queues on the guard unit display.



Delete/Cancel.

Press this button to delete the data entered or to cancel the call currently selected.



Call/Establish Communication.

Press this key to call the residential telephones or establish communication with a selected queued call.

For more information on the VDS Central Guard Unit, please consult manual code:
- 97001 VDS/ADS Guard Unit Manual.

Operating Modes

The characteristics of the different operating modes for buildings with one sole Central Guard unit are:

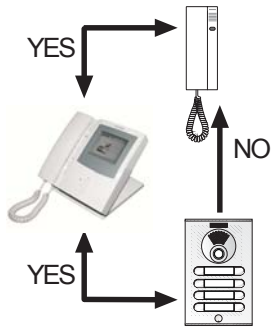

DAY MODE

- * The Central Guard Unit can call and receive calls from the telephones.
- * The outdoor entry panels cannot call the telephones directly.
- * The calls from the entry panel to the telephones are intercepted by the Central Guard Unit, who can transfer them to the telephone call or an alternate telephone.

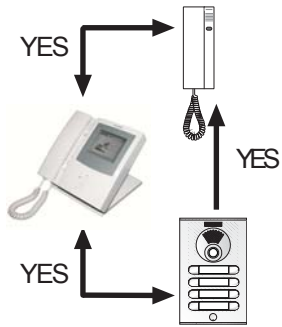

AUTOMATIC MODE

- * The Central Guard Unit can call and receive calls from the telephones.
- * The outdoor panels can call the telephones directly.
- * Calls from the outdoor entry panel to the telephones are monitored by the Guard Unit, the guard may answer the calls or not and transfer them to the particular residence or any other if he wishes.

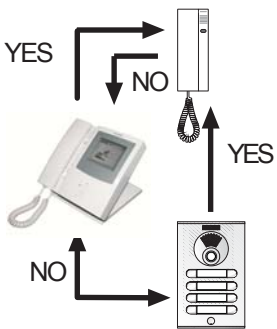

NIGHT MODE

- * The Central Guard Unit does not respond to telephone calls or calls from the entry panels. It operates as if it were an additional outdoor entry panel.
- * The outdoor entry panels can call the telephones directly.

Selecting the Operating MODE

1. Press **0**.

The display offers a series of instructions:

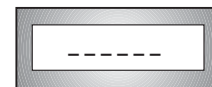

2. Press the key **A** followed by **3** to complete the steps:



The display will provide information on the current MODE:



3. Use the keys (under the display) to **select the required** MODE:

Day

Auto

Night

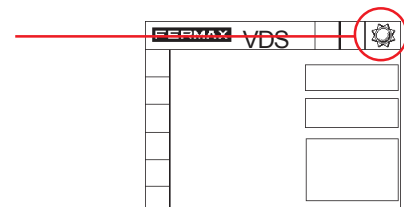

Press the key **B** when the required **MODE** appears on the display:



BASIC VDS SYSTEM DEVICES

In addition to the entry panels and guard units, the VDS system requires a number of basic devices to complete the system and ensure its correct operation.

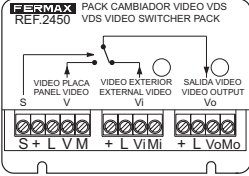
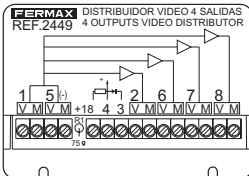
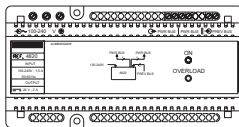
The functions of each of these devices is detailed below:

DEVICE	FUNCTION
<p>VDS Switcher (Ref. 2450)</p>	 <p>Necessary in VDS systems with 2 video door entry access points (this is not necessary in systems where one of the access points is audio only).</p> <p>Its aim is to select the video signal of the panel from which the call has been made.</p>
<p>Distributors (Ref. 2448, 2449)</p>	 <p>'Video Distributors' are required at all system points where there is video signal bifurcation: branch distribution, residence distribution per floor, etc.</p>
<p>VDS Power Supplies (Ref. 4830, 4810, 4812, 4800)</p>	 <p>VDS Power Supplies. Provide the system with power.</p> <p>Depending on the system (number of monitors/ telephones installed, type of lock release used, distance, etc.), the necessary voltage may vary by model and number of power supplies.</p>
<p>Lock-Releases</p>	 <p>The VDS systems permit alternating and continuous lock releases due to the potential-free relay present in the amplifier in outdoor entry panels.</p>

VDS Switcher (Ref.2450)

In VDS systems with **2 video door entry system access points** a «VDS Switcher ref.2450» is required.

Its aim is to select the video signal of the panel from which the call has been made. This selection is by way of a signal (negative) sent from this panel through a «S» wire (see wiring diagrams).

It is not necessary in systems in which one of the accesses is audio only.

In systems with a guard unit, this switcher is substituted for a «VDS Guard Unit Connection Module» Ref. 2492.

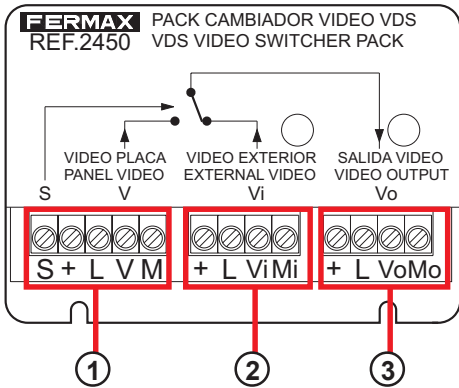

- ① Panel **Connector 1**: «S, +, L, V, M» connection wires from Panel 1.
- ② Panel **Connector 2**: «+, L, V, M» connection wires from Panel 2.
- ③ **Output Connector**: VDS output bus (audio + video) to monitor/telephone system.

The VDS switcher has 2 status options:

- **Standby**: switcher output connected to the Panel 2 input.

If Panel 2 is activated (after a call from a residence or auto-start), Panel 2's audio + video signals will be sent to the switcher output.

- **Active**: switcher output connected to the Panel 1 input.

When Panel 1 is activated (after a call from a residence or auto-start) a “negative” signal is sent via the «S» wire which activates the switcher, connecting the switcher output to the Panel 1 input.

The switcher returns to standby mode when Panel 1 is deactivated (end of communication).

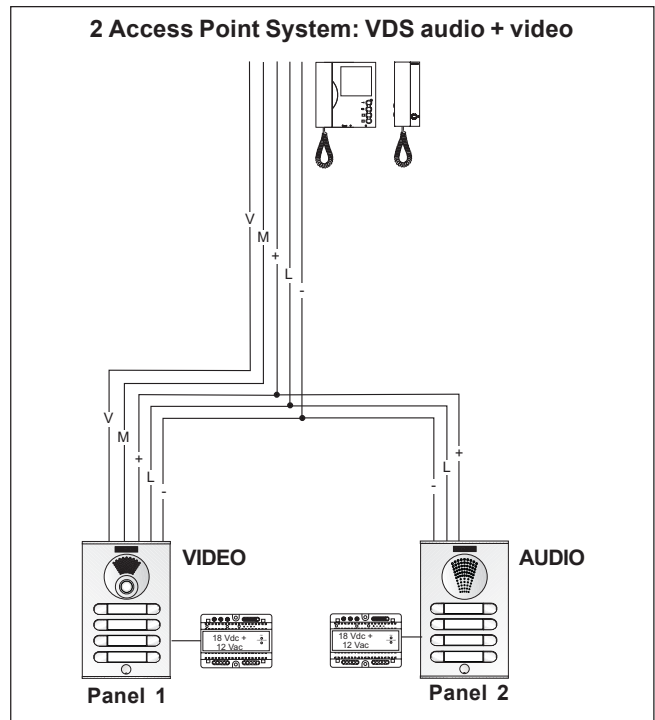
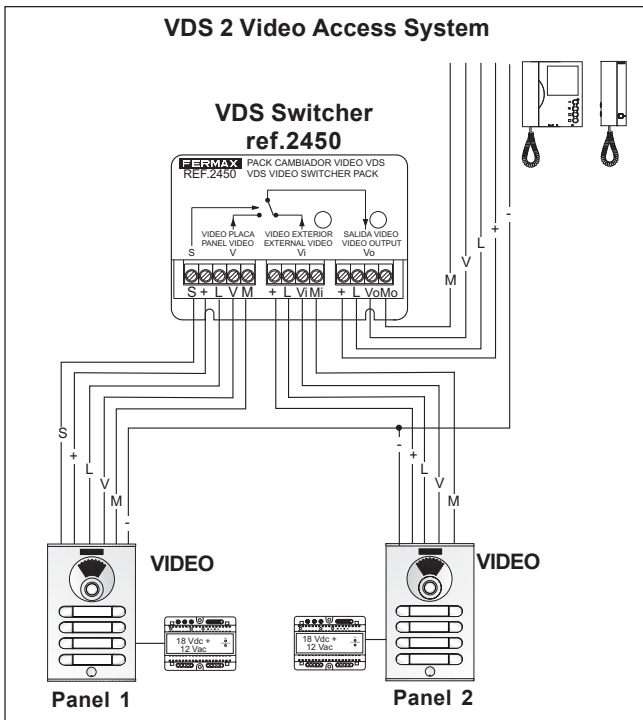

*** Technical Features**

Power supply		18 Vdc
Consumption	activated	15 mA
Dimensions (Height x Width x Depth)		61 x 86 x 21 mm // 2.4 x 3.4 x 0.8"

Video Distributors (Ref.2448 - 2449)

«Video Distributors» are required at all system points where there is video signal bifurcation: branch distribution, residence distribution per floor, etc.

There are two distributor models:

- Ref. 2448 2 output video distributor.
- Ref. 2449 4 output video distributor.

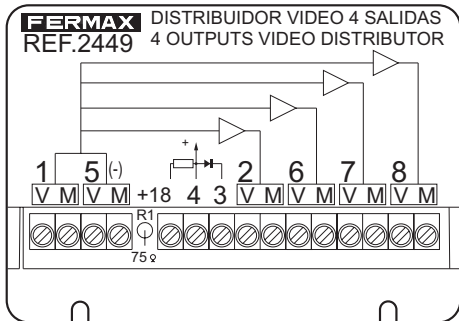

*** Connections**

5 (V,M): Video Input.

1 (V,M): Junction Output. Video output to next distributor.

2,6,7,8: Distribution Outputs: monitor connection or branch divisions.

Activation Mode:

4: CT Distributor Activation. Connect to the monitor's CT terminal.

+18: permanently activated distributor. Connect to +18 Vdc.

The distributors incorporate a voltage resistance of 75 ohms, which should only be cut when the no. 1 junction output is in use, that is, it will be cut in all the distributors in the chain, except the last in the line.

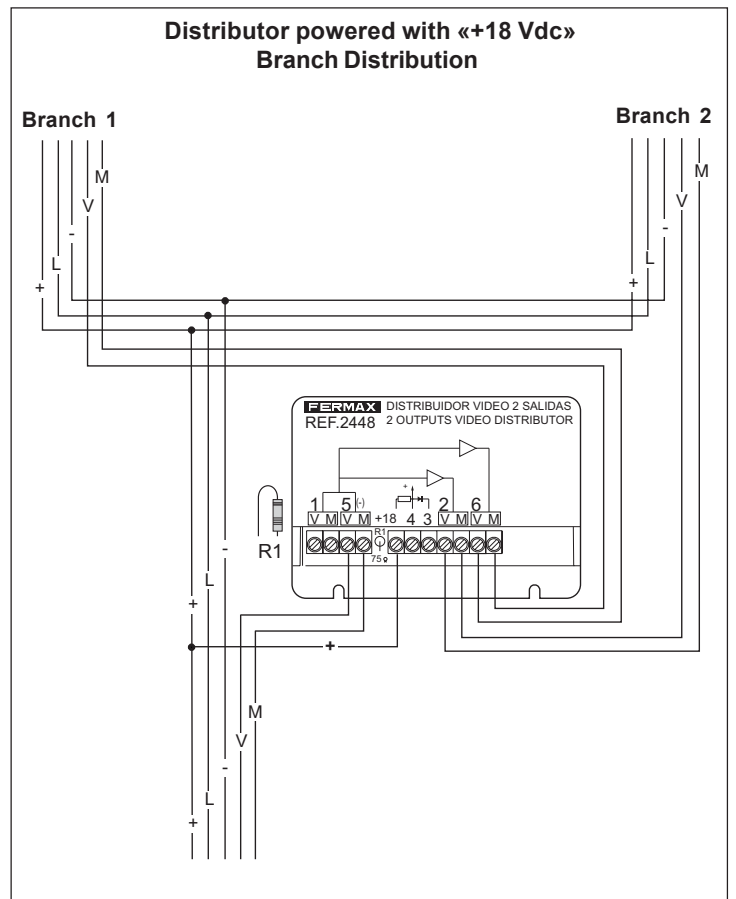
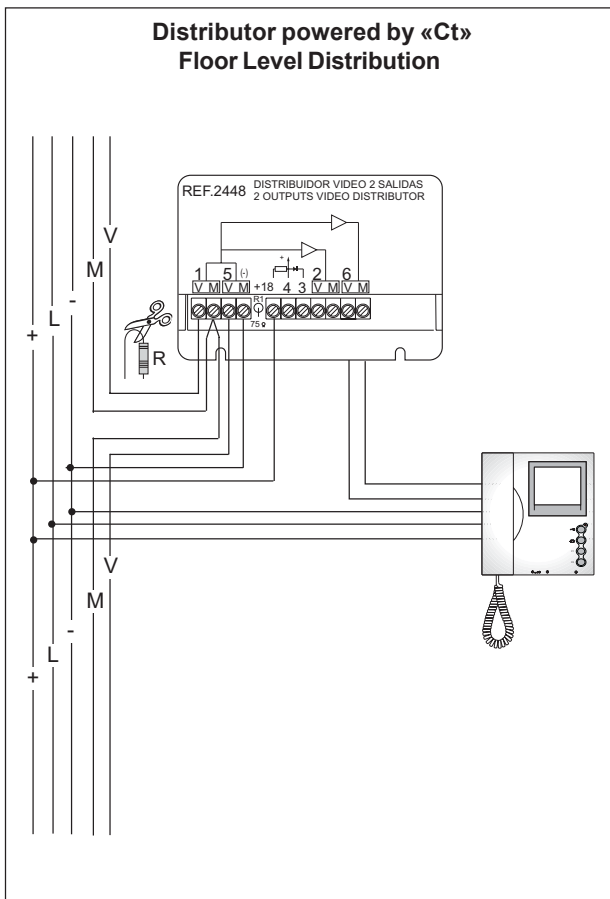

*** Technical Features**

Power Supply	activated by CT	8 ~14 Vdc
	activated by +18	15~24 Vdc
Consumption	activated	70 mA
Dimensions (Height x Width x Depth)		61 x 86 x 21 mm // 2.4 x 3.4 x 0.8"







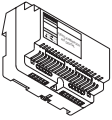
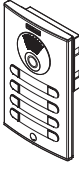

VDS system power supplies (power sources)

The correct operation of any electrical/electronic system largely depends on its power supply having the appropriate dimensions. As a result, it is important to take special care in selecting the model and number of power supplies necessary for the VDS door entry/video door entry systems.

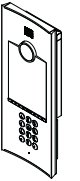
The VDS systems are powered with 18 Vdc, although depending on the system (number of monitors/telephones installed, type of door lock-release used, distance, etc.) the necessary power supply may vary in model and number:

- Source Ref. **4830**: 18Vdc 3.5A (DIN 6) with status LEDs ⁽¹⁾.
- Source Ref. **4810**: 12Vac/1.5A - 18Vdc/1.5A (DIN 10) with status LEDs ⁽¹⁾.
- Source Ref. **4812**: 18Vdc/1.5A (DIN 6) with status leds ⁽¹⁾.
- Source Ref. **4800**: 12Vac/1.5A (DIN 4).

* Maximum Source Capacities ⁽²⁾:

							COAXIAL		UTP CAT5 / 5 Wires	
										
4830 18Vdc/3.5A	-	1	-	1	-	80	-	50	-	
	1	-	-	1	-	-	40	-	24	
	-	-	1	1	-	-	40	-	24	
	-	-	-	-	-	80	-	50	-	
	-	-	-	-	-	-	40	-	24	
4812 18Vdc/1.5A	-	1	-	1	-	-	-	-	-	
	1	-	-	1	-	-	-	-	-	
	-	-	1	1	-	-	-	-	-	
	-	-	-	-	-	60	-	30	-	
	-	-	-	-	-	-	24	-	12	
4810 18Vdc/1.5A 12Vac/1.5A	-	1	-	-	1	60	-	30	-	
	1	-	-	-	1	-	24	-	12	
	-	-	1	-	1	-	-	-	-	
	-	-	-	-	-	60	-	30	-	
	-	-	-	-	-	-	24	-	12	
4800 18Vac/1.5A	-	-	-	-	2	-	-	-	-	

Symbols:

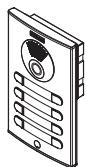

City Audio Panel
Citymax Audio Panel
Direct and Digital Audio Panel

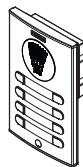

City Video Panel
Citymax Video Panel
Direct and Digital Video Panel



Halo Panel

⁽¹⁾ Source Status LEDs

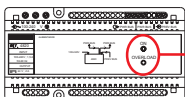

ON: On LED
OVERLOAD: Maximum current exceeded indicator LED. Reduce load.
ON + OVERLOAD: flashing light indicates short circuit

⁽²⁾ For replacement systems **check the sources' maximum capacities in the section on: «The VDS system in REPLACEMENT Installations»** in the relevant manual.

Electric door lock-release

The VDS amplifiers have a potential-free relay (C, No, Nc) which enables the use of both continuous and alternating door lock-release mechanisms (maximum 4A).

The 12 Vdc door lock-release power supply can be carried through the VDS amplifier (up to a maximum door lock-release consumption of 0.5A).

When using the alternating door lock-release, it will be necessary to use an additional alternative source (of sufficient dimensions), which via the relay contact, will provide the necessary current to activate the door lock-release.



*** Basic lock-release connection diagrams for the VDS system**

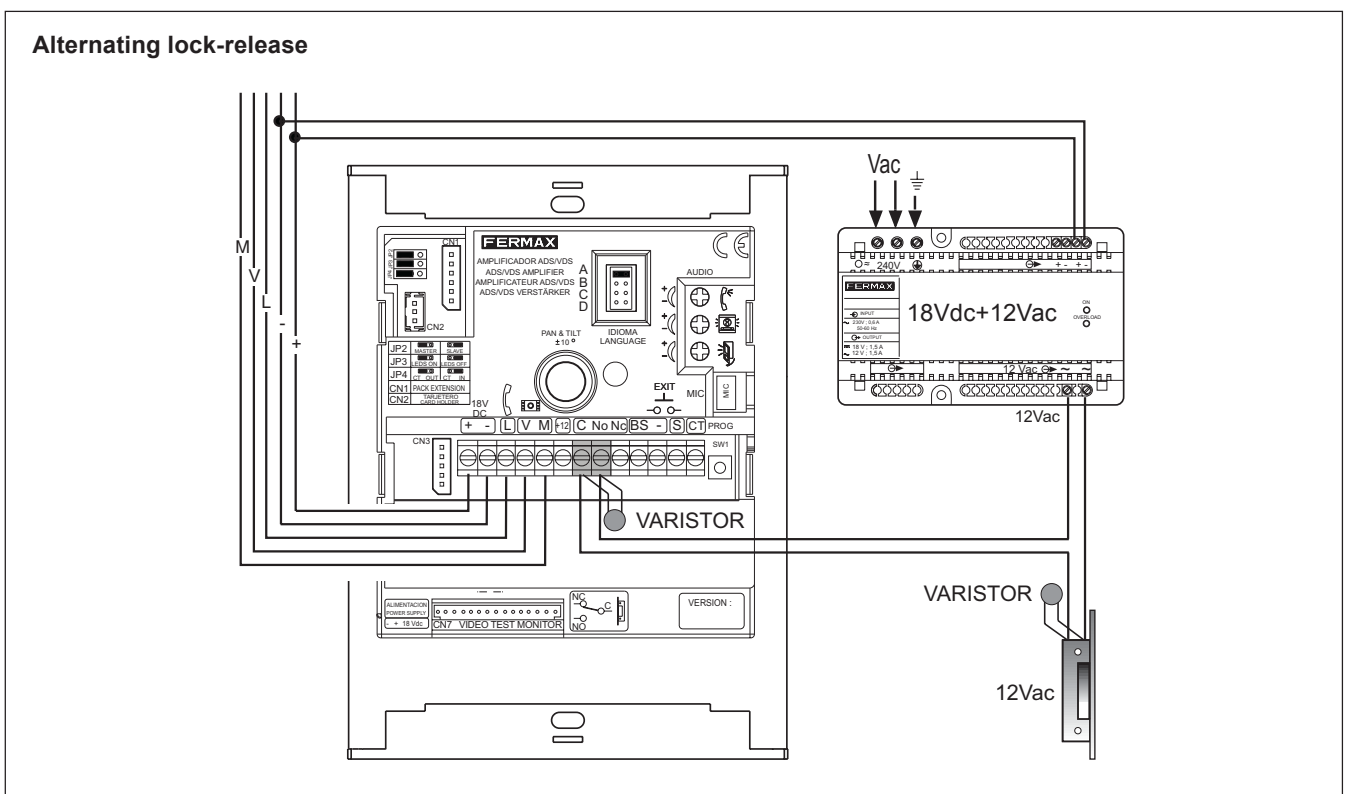
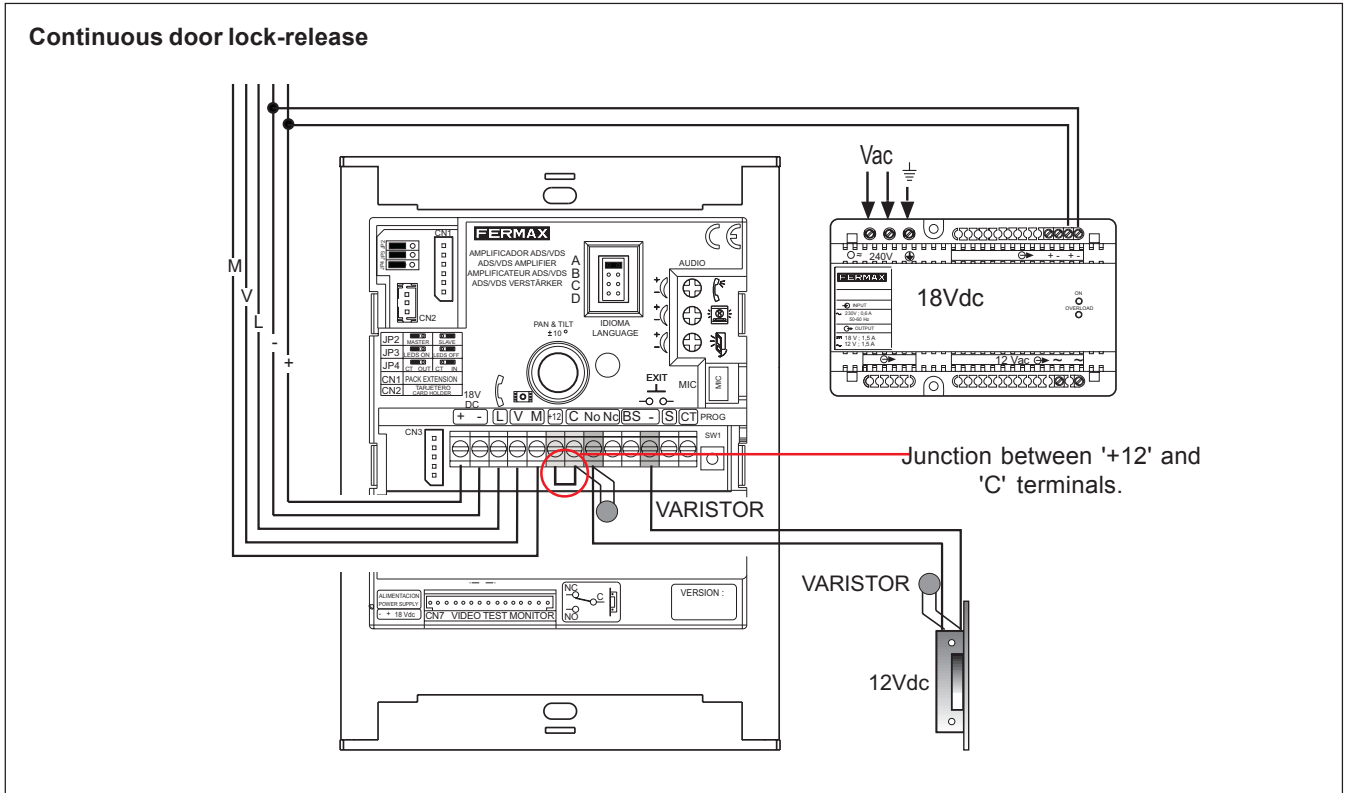

ACCESSORIES FOR VDS SYSTEMS

The VDS systems can be extended with multiple additional functions. The different accessories available for the extension of the VDS system are detailed below.

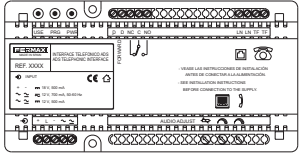
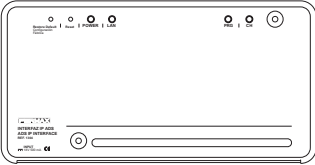
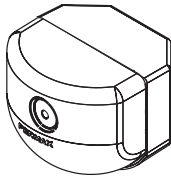
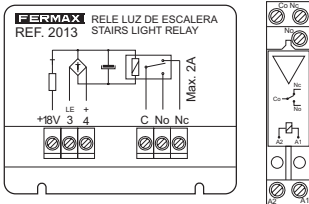
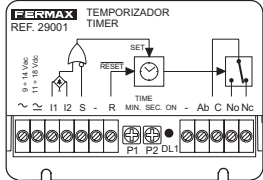
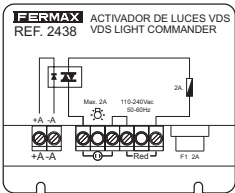
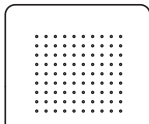
	DEVICE	FUNCTION
<p>Interface VDS Telephone Terminals (Ref. 1088)</p>		<p>Installed in the residence and connected to the telephone, it allows communication with the entry panel and the door be opened from any conventional fixed or wireless telephone.</p> <p>The telephone interface allows the user to forward calls from the door-entry system to a programmed external landline or mobile phone, to attend to visitors, open the door remotely or simulate presence when absent.</p> <p style="text-align: right;">Technical Documentation: Code 94809</p>
<p>IP Interface (Ref. 1304)</p>		<p>The IP interface allows calls be received on a PC from the VDS panels/guard unit via a local network or the internet, without the need for additional wiring.</p> <p>It has all the functions of a video door entry system: video, two way audio, door opening, auto-start, extended functions: record and play functions for video and images.</p> <p>These can be received on up to 4 computers.</p> <p style="text-align: right;">Technical Documentation: Code 97267</p>
<p>Aerial Camera Kit (Ref. 1072 / 1073)</p>		<p>Allows the user to extend the VDS video door entry system with various aerial cameras which can be viewed from the monitor within the residence.</p> <p>This application is useful for monitoring the rear of the residence in the case of chalets, to control the access door from an elevated position, control garage access, etc.</p> <p>The aerial camera is manufactured in zamak and glass-polycarbonate which is 2.5mm thick and resistant to impact. Its chassis which forms a 90° angle and its reversible wall support allow it to be fixed to any roof, wall or corner profile, at a 45° angle etc.</p> <p>Where there is more than 1 aerial camera the «8 Camera Selector» is required Ref. 2472.</p> <p style="text-align: right;">Technical Documentation: Code 94270 - 94285</p>
<p>Relays</p>		<p>Relays for additional functions. Allows electrical devices to be activated from an additional telephone or monitor button: stairway light activation, lock-release for second door, etc.</p> <p>Ref. 2013: 2A Relay. Technical Documentation: Code 94457 Ref. 3491: 12A DIN Rail Relay Technical Documentation: Code 97245 Ref. 88101 Double Contact Relay Technical Documentation: Code 94517</p>
<p>Timer (Ref. 29001)</p>		<p>Makes it possible to activate a device for a given time (programmable between 0 to 6 minutes or 0 to 60 seconds). The activation can be automatic when a call is received or by means of a specific button on the telephone or monitor.</p> <p style="text-align: right;">Technical Documentation: Code 94918</p>
<p>Light and Bell Activator (Ref 2438)</p>		<p>Makes it possible to activate high-power devices or indicators when a call is received: bells, sirens, light bulbs, etc.</p> <p style="text-align: right;">Technical Documentation: Code 94525</p>
<p>Call Extender Ref 2040</p>		<p>Device which when connected to the residential terminal allows the user hear the call tone from the extender.</p> <p style="text-align: right;">Technical Documentation: Code 94500</p>

For more information consult the devices' technical documentation on www.fermax.com.

RESIDENTIAL TERMINALS











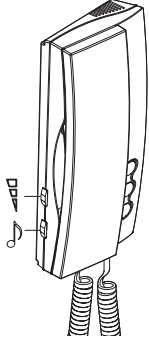

The VDS system has a wide range of residential terminals both for door entry systems (telephones) and video entry systems (monitors).

The residential terminals enable the user to establish audio/video communication with the outdoor entry panel, open the door, call the guard unit, etc.

Following installation, the VDS residential terminals require simple programming to assign the terminal with a code/call button to be entered or pressed from the outdoor entry panel in order to call the residence.

Audio Terminals: Telephones

The VDS telephones can be installed in telephone only systems, mixed monitor and telephone systems or as additional equipment in monitor systems.

TELEPHONE	INSTALLATION	COMMUNICATION	FEATURES
 <p>Loft BASIC Ref. 3390</p>	Surface	Telephone Receiver	<p> <i>Door lock-release / call guard unit button.</i></p> <ul style="list-style-type: none"> · When in conversation with the outdoor entry panel, press to activate the <i>door lock-release mechanism</i>. · With the monitor hung up, press to make a <i>call to the guard unit</i> (where a guard unit exists).
 <p>Loft EXTRA Ref. 3391</p>	Surface	Telephone Receiver	<p> <i>Door lock-release / call guard unit button.</i></p> <ul style="list-style-type: none"> · When in conversation with the outdoor entry panel, press to activate the <i>door lock-release mechanism</i>. · With the monitor hung up, press to make a <i>call to the guard unit</i> (where a guard unit exists). <p> F1 2 buttons for additional functions. Enables activation of relays (BUS2 or conventional) to use additional devices: secondary door opening, additional lighting activation, etc.</p> <p> F2</p> <p> ON/OFF switch with three positions:</p> <p>  Off  Switched on with medium volume  Switched on with high volume </p> <p> Call tone selector: 2 tones available.</p> <p>  Tone 1  Tone 2 </p>



Video terminals: Monitors

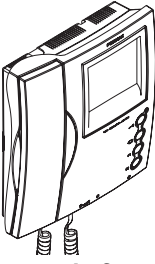
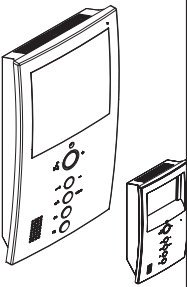
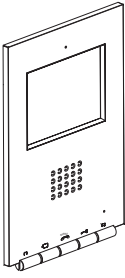

The VDS monitors should be installed in VDS video systems (with video panels). The video systems can be extended with monitors and/or additional telephones.

Fermax offers a wide range of monitors for the VDS system:

MONITOR	INSTALLATION	IMAGE	COMMUNICATION	SPECIAL FEATURES
 <p>Loft Ref. 3311-3305</p>	Surface	Black/White and Colour	Telephone Receiver	<ul style="list-style-type: none"> - Screen: Colour. TFT 3.5"; B/W: 4' Flatscreen - Image Adjustments: colour, shine and contrast using potentiometers. - ON/OFF switch with three positions: off/on medium volume/on low volume. - 2 selectable call tones
 <p>Loft Compact Ref. 3740-3753</p>	Surface and Flush-Mounted	Black/White and Colour	Hands Free: Half-Duplex (B/W Monitor) Full-Duplex (Colour Monitor)	<ul style="list-style-type: none"> - Programming from monitor - Screen: Colour. TFT 3.5"; B/W: 4' Flatscreen - Configuration through programming using monitor buttons: <ul style="list-style-type: none"> · Volume Adjustments: high-medium-low. · Call tone selector: various tones available. · Image adjustments: 4 pre-established configurations. · 'Mute' option (LED indicated activation).
 <p>iLoft Ref. 5610</p>	Flush-Mounted	Colour	Hands Free Full-Duplex	<ul style="list-style-type: none"> - Programming from monitor - Programming Display. - Screen: 4' TFT - Configuration programmed using monitor buttons: <ul style="list-style-type: none"> · Volume Adjustments: high-medium-low. · Call Tone Selector: various melodies available. · Image adjustments: 4 pre-established configurations. · 'Mute' option (LED indicated activation).

* Common functions on all VDS monitors

-  **Door lock-release / call guard unit button.**
 - When in conversation with the outdoor entry panel, press to activate the *door lock-release mechanism*.
 - With the monitor hung up, press to make a *call to the guard unit* (where a guard unit exists).
-  **Auto-Start Button: Manual Monitor Activation**

With the monitor on standby, press and hold this button for 1 second to switch the monitor on manually. To sequentially select between the camera on the main panel and the secondary panel (where one exists), hold the button down for 2 seconds.
-  **F1** Buttons for additional functions.
-  **F2** Allows the user activate relays to use additional devices: second door lock-release, additional lighting activation, etc.

Connectors and Connections

The VDS residential terminals (monitors/telephones) are fitted with connectors which are installed in the residence to connect the residential terminal to the system.

Depending on the residential terminal model, the connector format will vary, but not the main connection terminals (Bin, Bout, F1, F2, CT, T,...), so that the cabling for the various terminals is carried out following the same connection diagram.

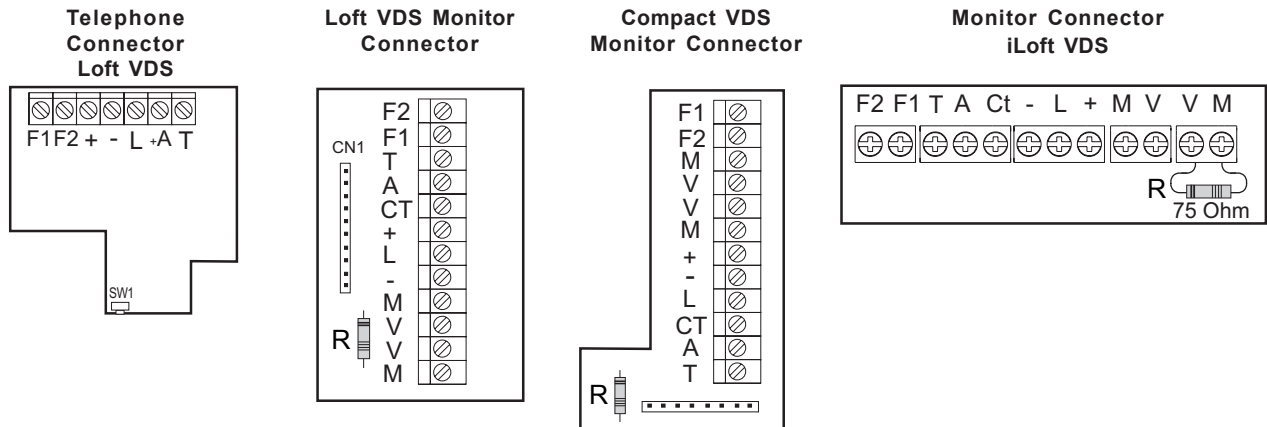

* Description of generic connection terminals for VDS terminals:

'+, -': Power Supply (18 Vdc).

'L': Audio and Data Wire

'V, M': Video Signal Connections (V: live; M: mesh).

'CT': 10 Vdc Output: auxiliary camera activation, floor level distributor, etc.

'A, +': Call Extension Connection Ref. 2040.

'T, -': Optional button connection for the residence's doorbell.

'F1, F2': Additional functions (negative output '-'). Maximum current per button F1, F2: 50mA at 12Vdc.

'R': 75 Ohm Resistance (final video load). With various monitors in cascade, cut the resistance in all monitors except the last one. If there are no monitors in cascade leave the resistance at 75 Ohms.

* Basic VDS terminal connection diagrams.

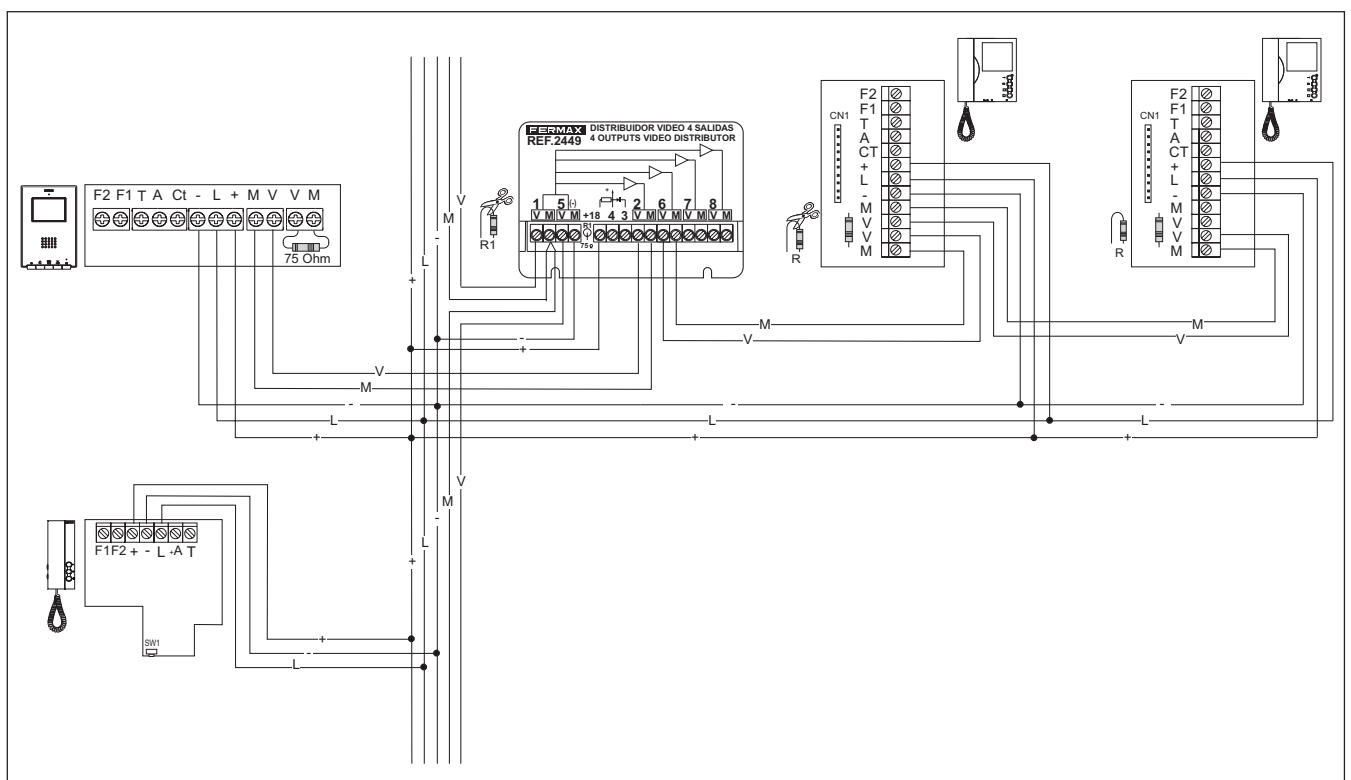

VDS Terminal Programming (monitors and telephones)

The programming procedure for VDS terminals is the same for monitors and telephones.

The residential terminals will not function if they have not been programmed

Terminal programming is carried out in 2 steps:

1.- Terminal Programming Setup:

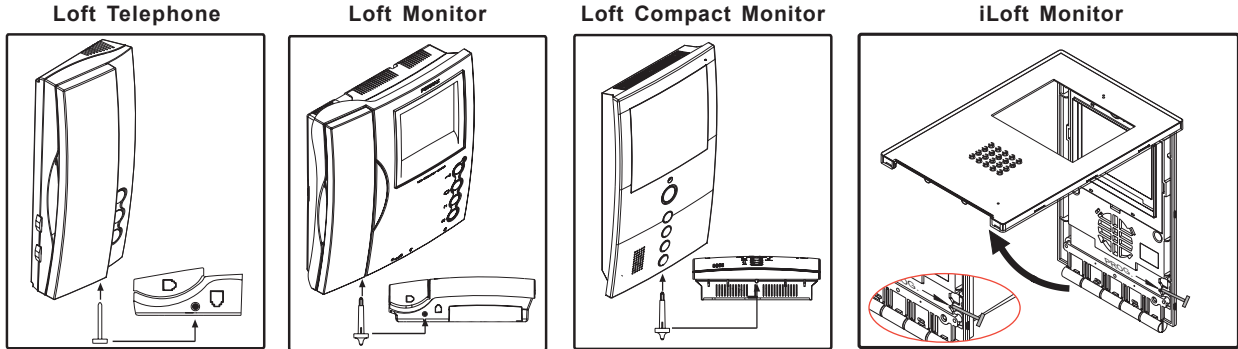

Press the monitor programming setup button.

2.- Allocation of Call Codes

Button Panels

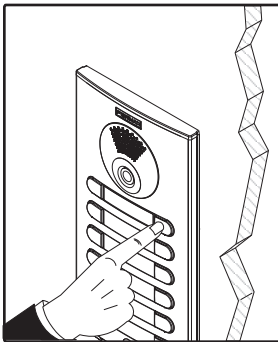

Press the residence's call button

Keypad Panels

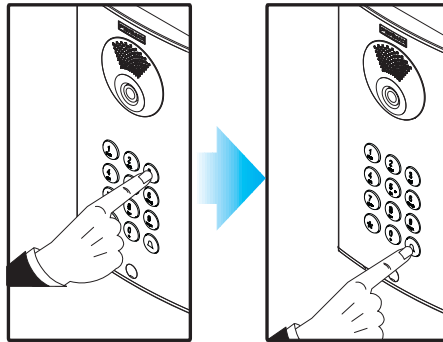

Using the keypad, enter the call code and press the bell

 A time frame of 2 minutes exists to carry out step 2 after terminal programming setup. Once this time has passed, the terminal will exit programming mode.

The Loft Compact and iLoft monitors have an additional function which enables monitor programming from the same monitor, without having to carry out any operation from the outdoor entry panel.

A detailed description of the features and functions corresponding to each terminal is given in the technical documentation:

Terminals	Reference Number	Documentation Code
Loft VDS Basic and Extra Telephone	390 - 3391	97331
Loft VDS Monitor, B/W and Colour	3311 - 3305	97493
Loft Compact Monitor, B/W and Colour	3740 - 3753	97093
iLoft VDS Monitor	5610	97315

Manuals available on the Fermax website: www.fermax.com.

The technical documentation codes may vary, refer to the Fermax website for the latest versions.

ADVANCED PROGRAMMING: Mapping in button panels

The call code generated by a button on one of the button panels is determined by the button's connection to the «call extension module» (in continuous profile button panels) or to the «button module» (in modular panels). See the 'Continuous Profile Panels and VDS Modular City' sections.

Mapping is an advanced programming function available in button panels, which allows modification of the call code assigned «naturally» to the buttons (based on their position on the call extension module or button module; sequentially from bottom to top and right to left). In this way it is possible to cover all button coding requirements:

Standard allocation through call extension module or button module

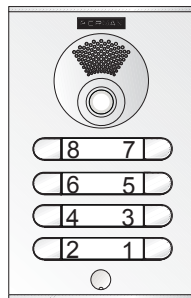

Mapping

Examples of possible assignments using the mapping functions

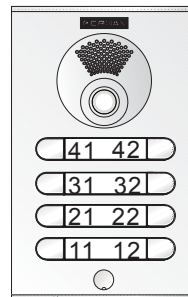

Floor/Residence
Very useful in systems with general MDS input

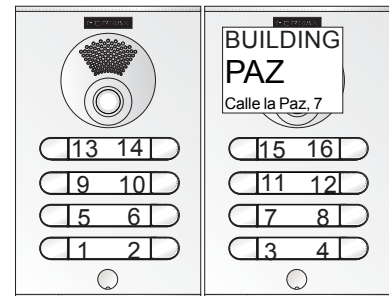

With double panels: call assignment depending on residence distribution per floor.

When mapping is carried out, the amplifier saves the link between the natural call code (address) and the newly assigned call code in a table.

Mapping

There are 2 ways of carrying out mapping:

1. Inverse Programming.

(Can only be done if there are monitors in all the residences. 2 operators are required).

Involves a method inverse to the current process. The steps to be followed are detailed below:

1. Programme the monitor from the entry panel or guard unit. (The iLOFT and Compact monitors allow programming via the monitor itself).
2. Select the «inverse button programming» mode on the VDS amplifier:
Press the SW1 button (a characteristic 'beep' will sound from loud speaker 2).
3. Assign the new addresses to each button:
 - 3.1. Activate the auto-start option on the monitor.
 - 3.2. Press the call button associated with this monitor (residence) on the entry panel.
The call code previously programmed on that monitor will be assigned to the button (it will be stored on the amplifier).

Repeat step 3 with all the monitors-buttons on the system.

4. Exit Programming:

Press the SW1 amplifier's "button programming" button again.

The amplifier will automatically exit the programming mode after 5 minutes of inactivity.

2. Sequential Programming.

This mapping programming mode allows call codes (addresses) to be assigned sequentially in whatever order you require.

The steps to be followed are detailed below

1. Select the 'sequential button programming' mode on the VDS amplifier:
Press the SW1 button for 5 seconds (a characteristic 'beep' will sound from loudspeaker 3).
2. Assign the new addresses to each button:
Press the call buttons in whatever order you wish, to assign the codes on the entry panel, starting with 1, and running sequentially to the last required number.
The amplifier stores each of the buttons' new call codes.
3. Exit Programming:
Press the SW1 amplifier's "button programming" button again.
The amplifier will automatically exit the programming mode after 5 minutes of inactivity.

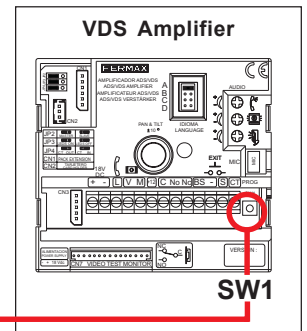

ADVANCED PROGRAMMING: *Door lock-release times on button panels*

There are two programmable lock-release activation times:

- Lock-release time set from the residence.
- Lock-release time set from the exit button (connected to the 'BS' and '-' terminals).

To programme the activation time follow the steps below:

1. With the power supply disconnected, execute a short circuit between the 'BS' and '-' (negative) terminals on the amplifier (or press the exit button if available).
2. Maintaining the short-circuit induced above, connect the system's power supply (at this point it will no longer be necessary to maintain the short circuit or hold down the button).
A confirmation tone will sound once you enter programming mode.
3. Following the confirmation tone, the lock-release ***time as currently programmed from the residence*** will be indicated by way of a number of beeps at 0.5 second intervals.
4. Once these indicator tones have concluded, or before they conclude, press any button on the panel, with one press for each second to be programmed (from 1 to 99 seconds).

To programme ***the lock-release time from the exit button***, while in time programming mode, (having finished programming the lock-release time from the residence or following the indicator tones), wait 5 seconds before taking any other action.

5. At this time a new confirmation tone will sound indicating the change to entrance hall lock-release programming mode, ***then subsequently emitting the aforementioned beeps detailing the time programmed.***

6. Once these indicator tones have concluded, or before they conclude, press any button on the panel, with one press for each second to be programmed (from 1 to 99 seconds).

To exit programming mode, wait 5 seconds without pressing any key. A 'MUOK' tone will sound to indicate that you have exited time programming mode.

If time programming mode is accessed and no button is pressed, the user will automatically exit after 30 seconds.

FERMAX

Audio and Video Door Entry Systems

www.fermax.com | fermax@fermax.com